

# INTERNATIONAL STANDARD

**ISO  
4672**

Third edition  
1997-03-01

---

---

## **Rubber and plastics hoses — Sub-ambient temperature flexibility tests**

*Tuyaux en caoutchouc et en plastique — Essais de souplesse à  
température inférieure à l'ambiante*

This material is reproduced from ISO documents under International Organization for Standardization (ISO) Copyright License number IHS/ICC/1996. Not for resale. No part of these ISO documents may be reproduced in any form, electronic retrieval system or otherwise, except as allowed in the copyright law of the country of use, or with the prior written consent of ISO (Case postale 56, 1211 Geneva 20, Switzerland, Fax +41 22 734 10 79), IHS or the ISO Licensor's members.



Reference number  
ISO 4672:1997(E)

**ISO 4672:1997(E)****Foreword**

ISO (the International Organization for Standardization) is a worldwide federation of national standards bodies (ISO member bodies). The work of preparing International Standards is normally carried out through ISO technical committees. Each member body interested in a subject for which a technical committee has been established has the right to be represented on that committee. International organizations, governmental and non-governmental, in liaison with ISO, also take part in the work. ISO collaborates closely with the International Electrotechnical Commission (IEC) on all matters of electrotechnical standardization.

Draft International Standards adopted by the technical committees are circulated to the member bodies for voting. Publication as an International Standard requires approval by at least 75 % of the member bodies casting a vote.

International Standard ISO 4672 was prepared by Technical Committee ISO/TC 45, *Rubber and rubber products*, Subcommittee SC 1, *Hoses (rubber and plastics)*.

This third edition cancels and replaces the second edition (ISO 4672:1988), which has been technically revised.

© ISO 1997

All rights reserved. Unless otherwise specified, no part of this publication may be reproduced or utilized in any form or by any means, electronic or mechanical, including photocopying and microfilm, without permission in writing from the publisher.

International Organization for Standardization  
Case postale 56 • CH-1211 Genève 20 • Switzerland  
Internet central@iso.ch  
X.400 c=ch; a=400net; p=iso; o=isocs; s=central

Printed in Switzerland

# Rubber and plastics hoses — Sub-ambient temperature flexibility tests

## 1 Scope

This International Standard specifies two methods for assessing whether a rubber or plastics hose retains adequate flexibility at sub-ambient temperatures.

Method A is applicable to non-collapsible hose with a nominal bore up to and including 25. It measures the increase in stiffness compared to the flexibility at a standard laboratory temperature.

Method B is a simpler, qualitative method suitable for control testing and is applicable to hose with a nominal bore up to and including 100.

## 2 Normative references

The following standards contain provisions which, through reference in this text, constitute provisions of this International Standard. At the time of publication, the editions indicated were valid. All standards are subject to revision, and parties to agreements based on this International Standard are encouraged to investigate the possibility of applying the most recent editions of the standards indicated below. Members of IEC and ISO maintain registers of currently valid International Standards.

ISO 471 : 1995 Rubber - Temperatures, humidities and times for conditioning and testing.

ISO 1402 : 1994 Rubber and plastics hoses and hose assemblies - Hydrostatic testing.

ISO 3383 : 1985 Rubber - General directions for achieving elevated or subnormal temperatures for test purposes.

## 3 Method A - Sub-ambient temperature stiffness test

### 3.1 Apparatus (see figure 1)

3.1.1 **Torque wheel**, having a diameter equal to twice the minimum bend radius specified for the hose, provided with equipment for holding the hose tangential to the wheel, a suitable device to bend the hose around the wheel, and a strain gauge and graphical recorder to measure the torque with an accuracy of  $\pm 3$  %. If the minimum bend radius is not specified the torque wheel shall have a diameter equal to 12 times the nominal bore of the hose.

3.1.2 **Cooling container**, equipped with an agitator, a temperature-measuring device and a roller having a diameter of 50 mm for guiding the hose.

The coolant shall not affect the hose to be tested and shall be used as prescribed in ISO 3383.

A suitable coolant liquid is methanol or ethanol with crushed dry ice (solid carbon dioxide) added. Gaseous coolants may be employed when the design of the apparatus is such that tests using such coolants give results equivalent to those obtained with liquid coolants.

## 3.2 Test specimens

### 3.2.1 Type

The test specimens shall be cut from the hose under test and shall have a length equal to

$$2(\pi R + d)$$

where

$R$  is the minimum bend radius as specified in the relevant hose product standard;

$d$  is the hose bore.

### 3.2.2 Number

At least three test specimens shall be used for each test.

No test shall be carried out less than 24 h after manufacture of the hose.

## 3.3 Test temperature

The test shall be conducted at one of the following temperatures:

- 0 °C ± 2 °C
- 10 °C ± 2 °C
- 25 °C ± 2 °C
- 40 °C ± 2 °C
- 55 °C ± 2 °C

or at any other sub-ambient temperature as defined in the relevant product standard.

### 3.4 Procedure

Clamp one end of the test specimen (3.2) on the wheel (3.1.1), with the rest of the specimen straight. If the hose has natural curvature, this curvature shall follow that of the wheel.

Without coolant in the container (3.1.2), determine the torque required to bend the test specimen through 180° round the wheel at the standard temperature chosen from those given in ISO 471. The time for bending shall be  $12 \text{ s} \pm 2 \text{ s}$ . Repeat the test with the container filled with coolant at the chosen test temperature (see 3.3). Condition the test specimen in a cold chamber at the test temperature for 24 h, followed by conditioning at the test temperature in the apparatus for at least 30 min before testing.

### 3.5 Expression of results

For each test specimen, calculate the mean torque at the standard temperature and the mean torque at the test temperature by calculating the mean of the peak values contained in the central 50 % of the respective torque traces.

Calculate the stiffness  $S$ , expressed as the ratio of the mean torque at the test temperature to that at the standard temperature, from the equation

$$S = \frac{T_t}{T_o}$$

where

$T_t$  is the torque at the test temperature (mean value from three tests);

$T_o$  is the torque at the standard temperature (mean value from the three tests).

If the individual values for the three test specimens do not agree to within 15 % of the mean value at each temperature, the test shall be repeated.

### 3.6 Test report

The test report shall include the following particulars:

- a) reference to this International Standard;
- b) a full description of the hose and its origin;
- c) the dimensions of the test specimens;
- d) the coolant used;

- e) the standard temperature and the test temperature;
- f) the torque at the standard temperature and at the test temperature;
- g) the calculated value of the stiffness.

## 4 Method B - Cold bend test

### 4.1 Apparatus

4.1.1 **Mandrel**, having an outside diameter equal to twice the minimum bend radius specified for the hose, or a former, with an arc of at least 180°. If the minimum bend radius is not specified, the mandrel or former shall have an outside diameter equal to 12 times the nominal bore of the hose.

4.1.2 **Conditioning chamber**, capable of being maintained at the specified temperature (see 4.3).

### 4.2 Test specimen

The test specimen shall be cut from the hose under test and shall have a length adequate to provide a grip at each end in addition to a section which can be bent round the periphery of the mandrel.

The test specimen shall be discarded on completion of the test.

### 4.3 Test temperature

The test shall be conducted at one of the following temperatures:

- 0 °C ± 2 °C
- 10 °C ± 2 °C
- 25 °C ± 2 °C
- 40 °C ± 2 °C
- 55 °C ± 2 °C

or at any other sub-ambient temperature as defined in the relevant product standard.

### 4.4 Procedure

Condition the mandrel (4.1.1) and the test specimen (4.2) in the conditioning chamber (4.1.2) at the chosen test temperature (see 4.3) for 24 h. Without removing them from the conditioning chamber, bend round the mandrel hoses of up to and including 22 nominal bore through 180° in 10 s ± 2 s and hoses of greater than 22 nominal bore through 90° in 10 s ± 2 s.

For hoses of greater than 22 nominal bore, testing outside the conditioning chamber is permitted, but precautions shall be taken against an unacceptable increase in the temperature of the specimen during the test.

Observe whether any cracking or breaking of the hose lining or cover occurs.

After bending, allow the test specimen to regain ambient temperature, and apply the specified proof test pressure, measured accurately in accordance with ISO 1402, to confirm whether or not any cracking or breaking of the lining or cover has occurred.

#### 4.5 Test report

The test report shall include the following particulars:

- a) a reference to this International Standard;
- b) a full description of the hose and its origin;
- c) the dimensions of the test specimen;
- d) the test temperature;
- e) the results of the visual examination of the test specimen after bending;
- f) the results of the visual examination after the proof pressure test;
- g) a description of the test procedure.

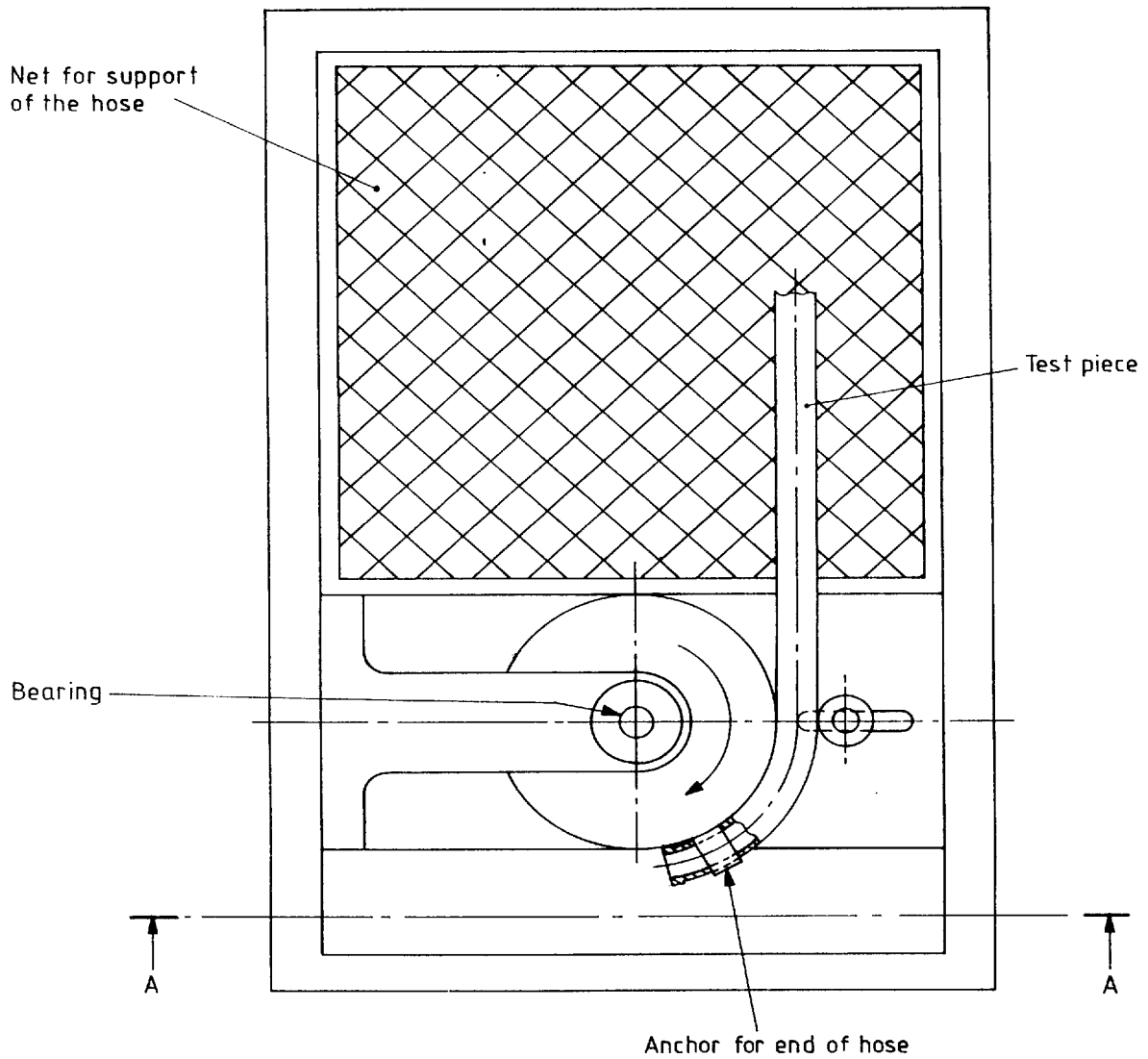
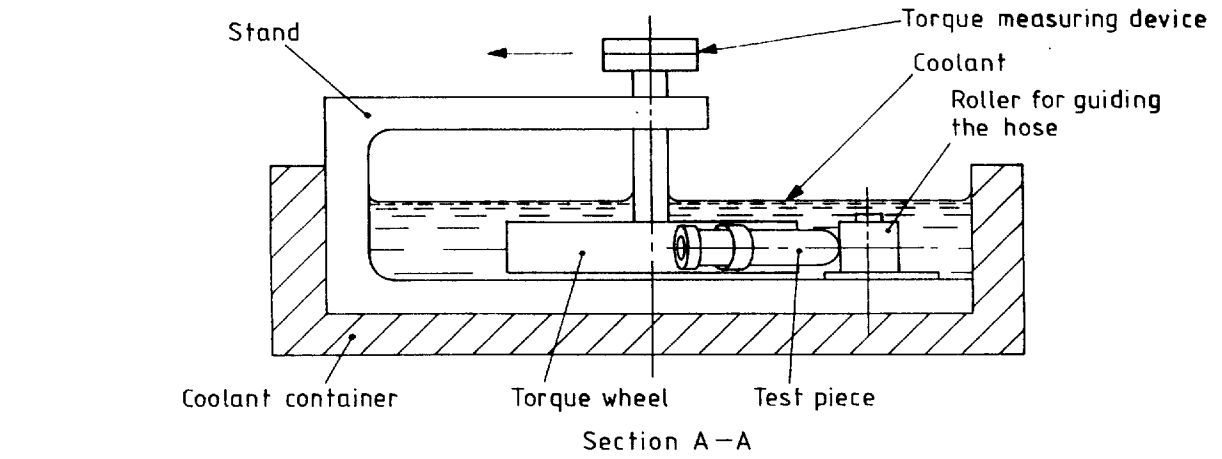

Figure 1 - Apparatus for method A



---

---

**ICS 23.040.70**

**Descriptors:** rubber products, plastics products, hoses, rubber hoses, plastics hoses, tests, low temperature tests, stiffness tests, bend tests, test equipment.

Price based on 6 pages

---

---