**Rubber and plastics hoses and hose
assemblies — Methods of measurement
of the dimensions of hoses and the
lengths of hose assemblies**

*Tuyaux et flexibles en caoutchouc et en plastique — Méthodes de
mesurage des dimensions des tuyaux et de la longueur des flexibles*



PDF disclaimer

This PDF file may contain embedded typefaces. In accordance with Adobe's licensing policy, this file may be printed or viewed but shall not be edited unless the typefaces which are embedded are licensed to and installed on the computer performing the editing. In downloading this file, parties accept therein the responsibility of not infringing Adobe's licensing policy. The ISO Central Secretariat accepts no liability in this area.

Adobe is a trademark of Adobe Systems Incorporated.

Details of the software products used to create this PDF file can be found in the General Info relative to the file; the PDF-creation parameters were optimized for printing. Every care has been taken to ensure that the file is suitable for use by ISO member bodies. In the unlikely event that a problem relating to it is found, please inform the Central Secretariat at the address given below.



COPYRIGHT PROTECTED DOCUMENT

© ISO 2007

All rights reserved. Unless otherwise specified, no part of this publication may be reproduced or utilized in any form or by any means, electronic or mechanical, including photocopying and microfilm, without permission in writing from either ISO at the address below or ISO's member body in the country of the requester.

ISO copyright office
Case postale 56 • CH-1211 Geneva 20
Tel. + 41 22 749 01 11
Fax + 41 22 749 09 47
E-mail copyright@iso.org
Web www.iso.org

Published in Switzerland

Contents

Page

Foreword.....	iv
1 Scope	1
2 Normative references	1
3 Test piece conditioning and temperature of measurement	1
4 Measurement of inside diameter.....	1
5 Measurement of outside diameter	3
6 Measurement of diameter over reinforcement	4
7 Measurement of wall thickness.....	4
8 Measurement of concentricity.....	5
9 Measurement of lining and cover thickness.....	6
10 Measurement of length and identification of measurement points.....	7
11 Verification of through-bore of hose assemblies.....	9
12 Test report	10
Bibliography	11

Foreword

ISO (the International Organization for Standardization) is a worldwide federation of national standards bodies (ISO member bodies). The work of preparing International Standards is normally carried out through ISO technical committees. Each member body interested in a subject for which a technical committee has been established has the right to be represented on that committee. International organizations, governmental and non-governmental, in liaison with ISO, also take part in the work. ISO collaborates closely with the International Electrotechnical Commission (IEC) on all matters of electrotechnical standardization.

International Standards are drafted in accordance with the rules given in the ISO/IEC Directives, Part 2.

The main task of technical committees is to prepare International Standards. Draft International Standards adopted by the technical committees are circulated to the member bodies for voting. Publication as an International Standard requires approval by at least 75 % of the member bodies casting a vote.

Attention is drawn to the possibility that some of the elements of this document may be the subject of patent rights. ISO shall not be held responsible for identifying any or all such patent rights.

ISO 4671 was prepared by Technical Committee ISO/TC 45, *Rubber and rubber products*, Subcommittee SC 1, *Hoses (rubber and plastics)*.

This third edition cancels and replaces the second edition (ISO 4671:1999), which has been technically revised. The main changes are the following:

- a clause has been added (Clause 3) specifying details of test piece conditioning and temperature of measurement;
- in 4.2, the use of tapered gauges has been added;
- in Clause 4, an additional method of measuring the inside diameter has been included (4.8);
- in Clause 5, an additional method of measuring the outside diameter has been included (5.6);
- in 7.1, the parts of hoses at which readings are to be taken have been specified;
- in 8.1, the parts of the hoses at which readings are to be taken have been specified;
- in Clause 8, three additional methods of measuring the concentricity have been included (8.4, 8.5 and 8.6);
- in 9.2, the method of measuring the lining and cover thickness has been modified.

Rubber and plastics hoses and hose assemblies — Methods of measurement of the dimensions of hoses and the lengths of hose assemblies

1 Scope

This International Standard specifies methods of measuring the inside diameter, outside diameter (including diameter over reinforcement of hydraulic hoses), wall thickness, concentricity and lining and cover thickness of hoses, methods of measurement and identification of the lengths of hoses and hose assemblies, and a method of verifying the through-bore of hydraulic hose assemblies.

2 Normative references

The following referenced documents are indispensable for the application of this document. For dated references, only the edition cited applies. For undated references, the latest edition of the referenced document (including any amendments) applies.

ISO 463, *Geometrical Product Specifications (GPS) — Dimensional measuring equipment — Design and metrological characteristics of mechanical dial gauges*

ISO 3599, *Vernier callipers reading to 0,1 and 0,05 mm*

ISO 3611, *Micrometer callipers for external measurement*

3 Test piece conditioning and temperature of measurement

3.1 Conditioning of test pieces

Unless otherwise specified, test pieces shall be taken at least 16 h after manufacture of the hose and conditioned at 23_{-3}^{+7} °C for at least 3 h before measurement. This 3 h may be included in the 16 h.

3.2 Measurement temperature

Unless otherwise specified, the measurement temperature shall be 23_{-3}^{+7} °C.

4 Measurement of inside diameter

4.1 General

Measurements by methods 1 to 7 may be made either on the ends of a full length of hose or on a test piece (minimum length 150 mm) cut from a full length. For wire-reinforced hydraulic hoses, measurements shall be made at a minimum distance of 25 mm from the end of the hose.

Measurements shall be made using one of the following methods, as appropriate.

4.2 Method 1

For inside diameters less than 150 mm and for all sizes of collapsible hose, plug gauges with 0,25 mm increments in diameter (see Figure 1) and tapered gauges with 0,1 mm increments in diameter (see Figure 2) may be used. Insert the gauge into the hose test piece gently without pressure. Take special care if the hose bore is not precisely circular.

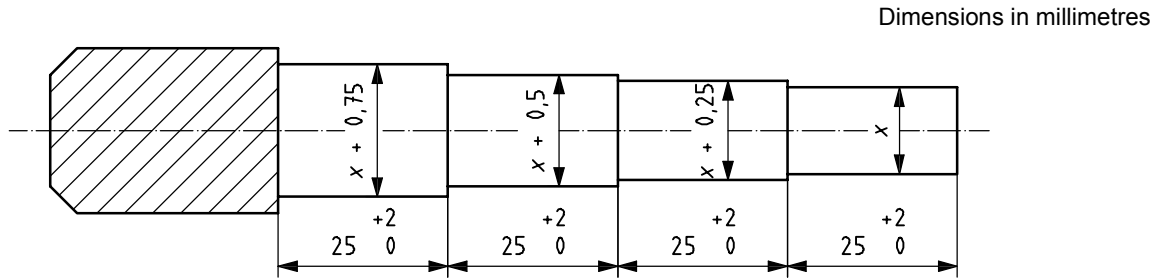

Figure 1 — Plug gauges

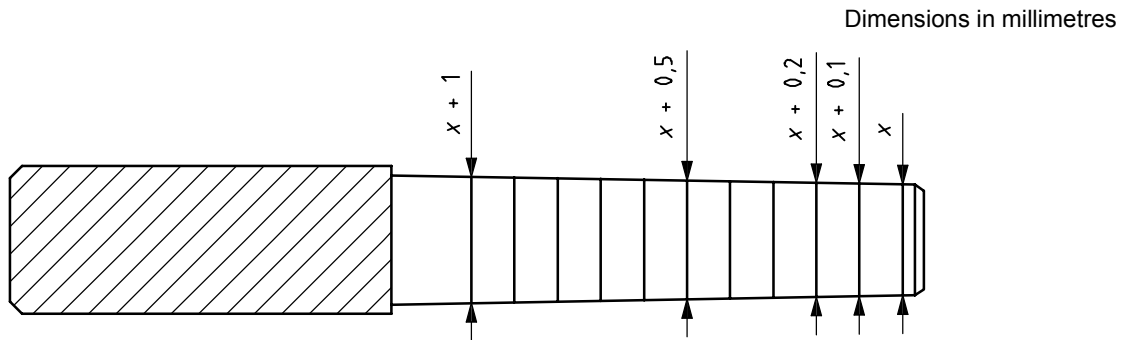

Figure 2 — Tapered gauges

4.3 Method 2

For inside diameters less than 63 mm, where greater accuracy is required, for example for wire-reinforced hydraulic hoses, an expanding ball or telescopic gauge may be used.

4.4 Method 3

For all inside diameters up to and including 100 mm, the internal jaws of vernier slide callipers complying with the requirements of ISO 3599 may be used. Make two measurements at right angles to each other and take their average as the inside diameter. Take care not to distort the hose when making the measurements. Callipers of suitable size may be used for nominal bores above 100 when greater accuracy than is obtainable by Method 5 (see 4.6) is required.

4.5 Method 4

For all inside diameters, an internal calliper dial gauge (see ISO 463) with rounded feet designed for use in bores made of elastomeric material may be used, a calliper size being chosen which is suitable for the inside diameter to be measured. Make two measurements at right angles to each other and take their average as the inside diameter.

4.6 Method 5

For inside diameters above 100 mm, a sufficient degree of accuracy for normal purposes is obtained by the use of a graduated steel rule. Alternatively, digital callipers or a digital micrometer may be used. Make two measurements at right angles to each other and take their average as the inside diameter.

4.7 Method 6

For suitable diameters, and where the hose cross-section has not been distorted by the cutting operation, an optical magnifier with a scale graduated in 0,1 mm divisions may be used. Make two measurements at right angles to each other and take their average as the inside diameter.

4.8 Method 7

For inside diameters above 300 mm, a sufficient degree of accuracy for normal purposes is obtained by measuring the inside circumference of the hose with a measuring tape. The inside diameter is obtained by dividing the measured value by pi (π). A measuring tape graduated in centimetres may be used.

5 Measurement of outside diameter

5.1 General

Measurements made by methods 1 to 5 may be made either on a full length of hose or on a test piece (minimum length 150 mm) cut from a full length. Measurements shall be made at a minimum distance of 25 mm from the ends of the hose. If the cover is fluted or corrugated, measurements shall be made at the top of an outward-projecting part of the cover.

Measurements shall be made using one of the following methods, as appropriate.

5.2 Method 1

For outside diameters up to and including 100 mm, vernier slide callipers, or a micrometer complying with the requirements of ISO 3611, may be used. Make two measurements at right angles to each other and take their average as the outside diameter. Take care to avoid distorting the hose when making the measurements. When greater accuracy is required, place the test piece on a mandrel of outside diameter equal to the hose inside diameter to prevent distortion.

5.3 Method 2

For outside diameters over 20 mm, a vernier stepped pi-tape may be used.

5.4 Method 3

For outside diameters over 100 mm, a flexible tape graduated to give the diameter directly may be used, or the circumference may be measured using a flexible tape and the diameter calculated from it.

5.5 Method 4

For suitable diameters, and where the hose cross-section has not been distorted by the cutting operation, an optical magnifier with a scale graduated in 0,1 mm divisions may be used. Alternatively, a laser measuring device may be used. Make two measurements at right angles to each other and take their average as the outside diameter.

5.6 Method 5

For all outside diameters, laser micrometers may be used. Make two measurements at right angles to each other and take their average as the outside diameter.

6 Measurement of diameter over reinforcement

Measurement of the diameter over reinforcement is normally confined to hydraulic hoses in connection with the fitting of couplings and shall be carried out on a test piece cut from the hose.

Make measurements in accordance with 5.2 or 5.3, after completely removing the cover material.

7 Measurement of wall thickness

7.1 General

Where knowledge of the wall thickness is required, it is normally sufficient to calculate this by taking half the difference between the outside and inside diameters. Alternatively, the wall thickness may be measured directly using one of the following methods. The readings shall be taken at the end of the hose test piece for methods 1 and 4 and at a minimum distance of 15 mm from the end of the hose test piece for methods 2 and 3.

7.2 Method 1

Use vernier slide callipers, taking care to avoid errors due to curvature.

7.3 Method 2

Use a micrometer with a rounded anvil contacting the inside of the hose, or a dial gauge using an arrangement similar to that shown in Figure 3.

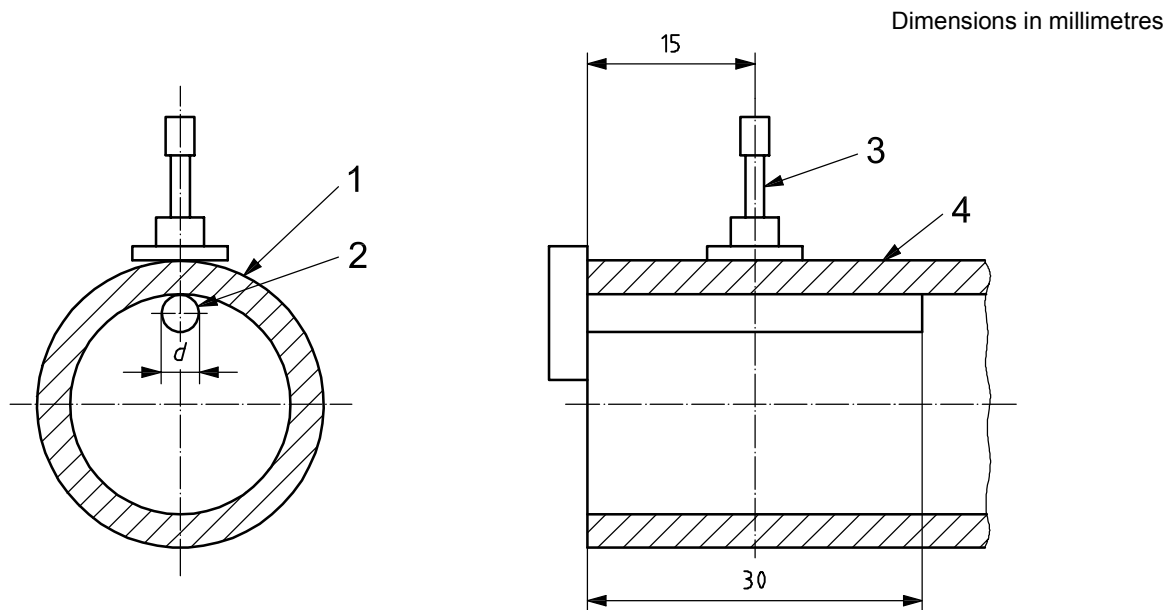

Key

- 1 hose
- 2 hose support or anvil
- 3 dial-indicator spindle
- 4 hose (minimum length 30 mm)

$d = 3$ mm for hoses up to and including inside diameter 6 mm

$d = 6$ mm for hoses above 6 mm inside diameter

Figure 3 — Suitable arrangement for the measurement of the wall thickness of a hose using a dial gauge

7.4 Method 3

Use a thickness calliper dial gauge with rounded feet designed for use with elastomeric materials.

7.5 Method 4

Use an optical magnifier with a scale graduated in 0,1 mm divisions.

8 Measurement of concentricity

8.1 General

The concentricity is the difference between the highest and lowest readings of the inside diameter and the outside diameter of the hose construction or the difference between the highest and lowest readings of the inside diameter and the diameter over the reinforcement. The readings shall be taken at the end of the hose test piece for methods 3 and 5 and at a minimum distance of 15 mm from the end of the test piece for methods 1, 2 and 4.

8.2 Method 1

Mount the hose test piece on a mandrel of outside diameter equal to the hose inside diameter, the ends of which rest in vee-blocks. Use a dial indicator gauge to obtain the difference between the highest and lowest readings around the circumference.

8.3 Method 2

Use a micrometer with a rounded anvil contacting the inside of the hose or a dial gauge using an arrangement similar to that shown in Figure 3 to obtain the difference between the highest and lowest readings.

For hoses of inside diameter 63 mm and over, take eight readings at 45° intervals around the circumference.

For hoses of inside diameter less than 63 mm, take four readings at 90° intervals around the circumference.

8.4 Method 3

Use vernier slide callipers, taking care to minimize errors due to curvature. For hoses of inside diameter less than 63 mm, the difference between the highest and lowest readings is obtained by taking four readings at 90° intervals around the circumference. For hoses of inside diameter 63 mm and over, the difference between the highest and lowest readings is obtained by taking eight readings at 45° intervals around the circumference.

8.5 Method 4

Use a thickness calliper dial gauge with rounded feet designed for use with elastomeric materials. For hoses of inside diameter less than 63 mm, the difference between the highest and lowest readings is obtained by taking four readings at 90° intervals around the circumference. For hoses of inside diameter 63 mm and over, the difference between the highest and lowest readings is obtained by taking eight readings at 45° intervals around the circumference.

8.6 Method 5

Use an optical magnifying glass with a scale graduated in 0,1 mm divisions. For hoses of inside diameter less than 63 mm, the difference between the highest and lowest readings is obtained by taking four readings at 90° intervals around the circumference. For hoses of inside diameter 63 mm and over, the difference between the highest and lowest readings is obtained by taking eight readings at 45° intervals around the circumference.

9 Measurement of lining and cover thickness

9.1 General

Three methods are specified. In method 1, the thickness of the lining and cover is measured at a cut edge of the test piece. This method is suitable not only for hoses with smooth covers but also for those with fluted and corrugated covers. Method 2 is intended for use with hoses incorporating a reinforcement. Method 3 measures the cover thickness only.

9.2 Method 1

9.2.1 With fluted and smooth covers, cut four test pieces 25 mm or more in length from the hose. Measure the thickness of the lining and cover at each end of each test piece, at the thinnest point (i.e. between the projections) in the case of fluted covers, using an optical magnifying glass with a scale graduated in 0,1 mm divisions. Record the average of the eight measurements as the thickness of the lining and cover.

9.2.2 With corrugated covers, take a test piece approximately 50 mm in length from the hose and mark a diameter on each end, the two diameters being at right angles to one another [see Figure 4 a)]. Cut the test piece into equal portions and then bisect each portion by cutting longitudinally along the marked diameters [see Figures 4 b) and 4 c)].

Measure the thickness of the lining and cover on each segment at the thinnest point on each of the eight longitudinal cut edges, using an optical magnifying glass with a scale graduated in 0,1 mm divisions.

Record the average of the eight measurements as the thickness of the lining and cover.

9.3 Method 2

9.3.1 In this method, the thickness of the lining and cover is measured, on a test piece of any suitable length, using a standard micrometer graduated at 0,02 mm intervals and having a presser foot 3 mm to 10 mm in diameter exerting a pressure of 22 kPa \pm 5 kPa.

9.3.2 With hoses incorporating a braid or helical-wound reinforcement, strip the hose and cover from the reinforcement and measure the thickness with the micrometer in two directions at 90° intervals round the circumference. Then buff the hose and cover just sufficiently to remove the corrugations caused by the reinforcement and repeat the thickness measurements. Record the average of the four readings as the lining and cover thickness.

9.3.3 With hoses incorporating a woven reinforcement, strip the hose and cover from the reinforcement and buff just sufficiently to remove the corrugations caused by the reinforcement. Measure the thickness with the micrometer in two directions at 90° intervals round the circumference. Record the average of the two readings as the lining and cover thickness.

9.4 Method 3

Where the maximum cover thickness is specified for wire-reinforced hoses, measure the cover thickness by means of a dial indicator depth gauge having a rounded foot placed parallel to the hose, bridging a groove obtained by stripping a 12,5 mm to 25 mm width of cover from the hose. Place a mandrel in the hose bore to ensure that misalignment is minimized. Record the difference between the highest and lowest readings around the circumference as the maximum cover thickness.

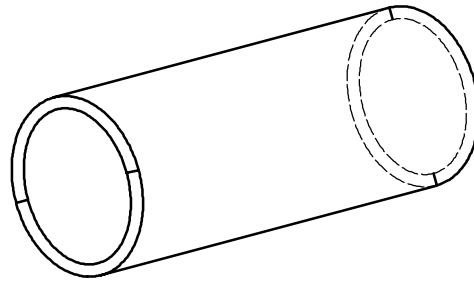

a) Diameter marked

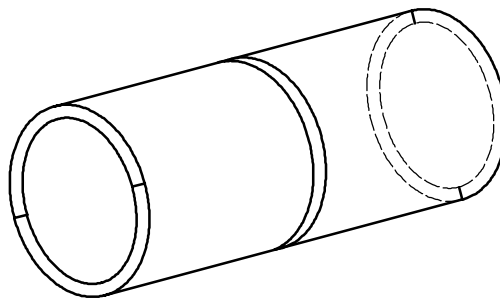

b) Test piece cut in half

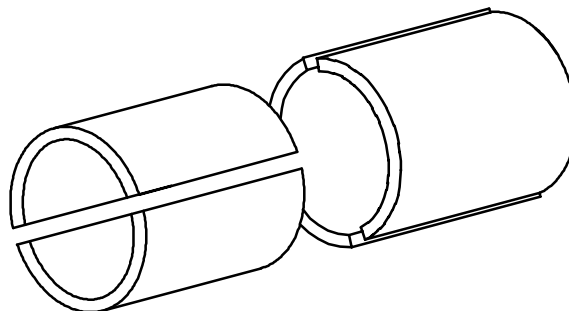

c) Each half bisected

Figure 4 — Measurement of lining and cover thickness

10 Measurement of length and identification of measurement points

10.1 Measurement of length

For lengths of up to and including 20 m, measure the length with a graduated steel tape or, with short lengths, a metal rule or, with very short lengths, vernier slide callipers. For lengths over 20 m, measure the length with a graduated steel tape or a wheel-type measurement gauge.

Make all measurements with the hose in the straight and unstretched condition.

10.2 Measurement points

10.2.1 Hoses

Determine the length of the hose between the extreme ends of the cut length.

10.2.2 Hose assemblies

Ensure that the points between which the length of the assembly is to be measured are identified. Figures 5 to 10 show typical end fittings and how to identify the different measurement points.

For hose assemblies with end fittings not illustrated in Figures 5 to 10, ensure that the measurement point on the fitting is identified from the fitting manufacturer's published data.

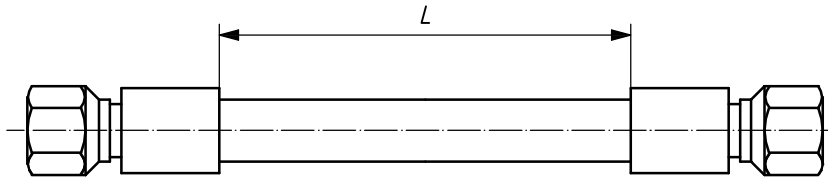

Figure 5 — Length of exposed hose between couplings

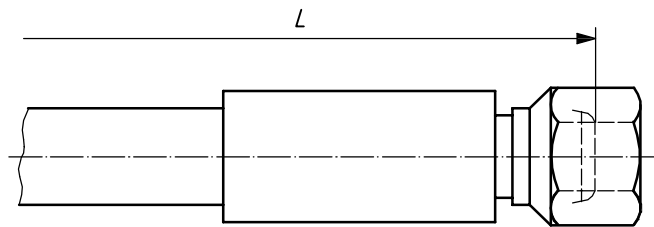

Figure 6 — Length to nipple of the coupling (female)

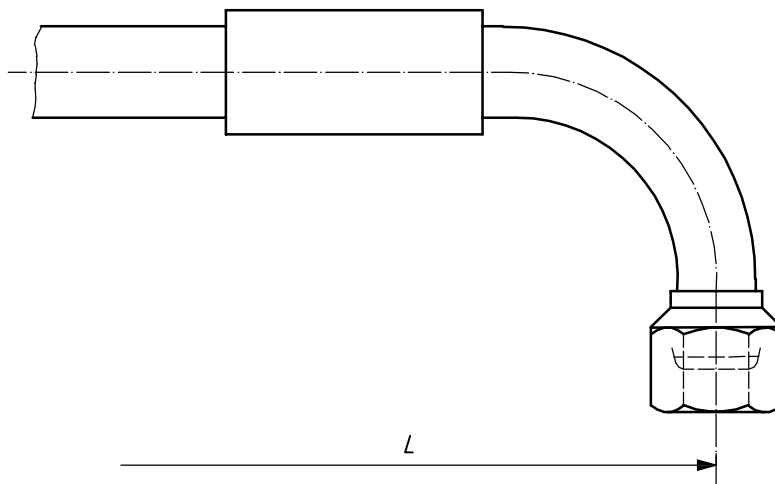

Figure 7 — Length from centreline of nipple (90° angle) of a coupling (female)

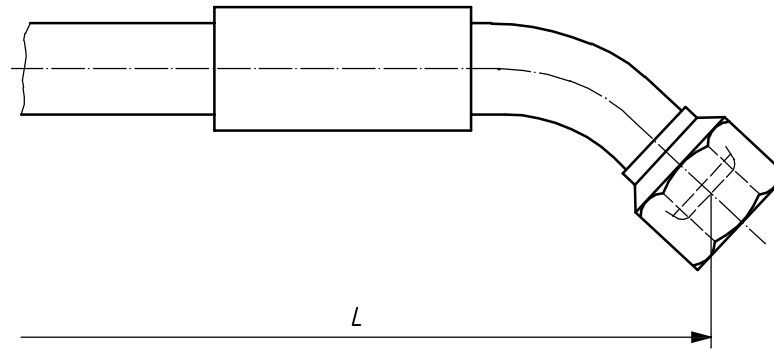

Figure 8 — Length from centreline of nipple (45° angle) of a coupling (female)

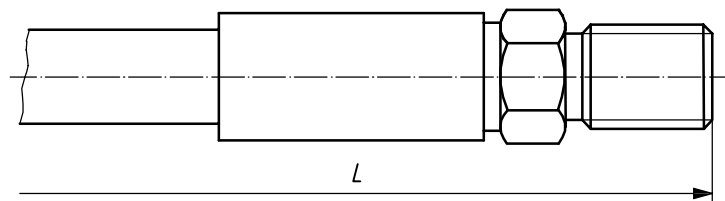

Figure 9 — Length to nipple of coupling (male)

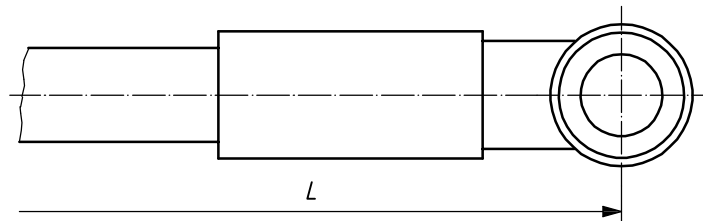

Figure 10 — Length from centreline of a banjo coupling

11 Verification of through-bore of hose assemblies

This test is applied to hose assemblies fitted with end couplings to confirm that the bore through the assembly, including any bulge or constriction resulting from attachment of couplings, is not less than a specified value.

Carry out the test by determining whether a test ball of specified size passes completely through the assembly.

NOTE It is recommended that hose specifications specify the size of ball to be used, choosing a standard ball-bearing size, rather than quote a percentage of the inside diameter, since the latter usually results in non-standard ball sizes that are not readily obtainable.

12 Test report

The test report shall include the following information, as appropriate:

- a) a reference to this International Standard;
- b) a full description of the hose or hose assembly tested;
- c) the date of the test;
- d) the inside diameter, including the method used and the individual readings obtained;
- e) the outside diameter, including the method used and the individual readings obtained;
- f) the diameter over reinforcement, including the method used and the individual readings obtained;
- g) the wall thickness, including the method used and the individual readings obtained;
- h) the concentricity, including the method used and the individual readings obtained;
- i) the lining thickness, including the method used and the individual readings obtained;
- j) the cover thickness, including the method used and the individual readings obtained;
- k) the length of the hose or hose assembly, including the method and measurement points used;
- l) the size of the ball used for the through-bore test and whether the ball passed freely and completely through the assembly.

Bibliography

- [1] ISO 8330, *Rubber and plastics hoses and hose assemblies — Vocabulary*

