

---

---

**Rubber, vulcanized — Determination  
of temperature rise and resistance to  
fatigue in flexometer testing —**

Part 3:  
**Compression flexometer (constant-  
strain type)**

*Caoutchouc vulcanisé — Détermination de l'élévation de température  
et de la résistance à la fatigue dans les essais aux flexomètres —*

*Partie 3: Flexomètre à compression (type à déformation constante)*



**COPYRIGHT PROTECTED DOCUMENT**

© ISO 2016, Published in Switzerland

All rights reserved. Unless otherwise specified, no part of this publication may be reproduced or utilized otherwise in any form or by any means, electronic or mechanical, including photocopying, or posting on the internet or an intranet, without prior written permission. Permission can be requested from either ISO at the address below or ISO's member body in the country of the requester.

ISO copyright office  
Ch. de Blandonnet 8 • CP 401  
CH-1214 Vernier, Geneva, Switzerland  
Tel. +41 22 749 01 11  
Fax +41 22 749 09 47  
copyright@iso.org  
www.iso.org

# Contents

Page

<b>Foreword</b> .....	<b>iv</b>
<b>Introduction</b> .....	<b>v</b>
<b>1 Scope</b> .....	<b>1</b>
<b>2 Normative references</b> .....	<b>1</b>
<b>3 Terms and definitions</b> .....	<b>1</b>
<b>4 Principle</b> .....	<b>2</b>
<b>5 Apparatus</b> .....	<b>2</b>
5.1 Flexometer.....	2
5.1.1 General description.....	2
5.1.2 Detailed description.....	2
5.2 Measuring gauge.....	4
5.3 Timer.....	4
<b>6 Calibration</b> .....	<b>4</b>
<b>7 Test piece</b> .....	<b>4</b>
<b>8 Test conditions</b> .....	<b>5</b>
<b>9 Procedure</b> .....	<b>6</b>
9.1 Preparation of flexometer.....	6
9.2 Test procedure.....	6
9.2.1 General.....	6
9.2.2 Determination of temperature rise and of compression set.....	7
9.2.3 Determination of fatigue resistance.....	7
9.2.4 Determination of creep.....	7
<b>10 Expression of results</b> .....	<b>8</b>
10.1 Temperature rise.....	8
10.2 Creep.....	8
10.3 Compression set.....	9
10.4 Fatigue life.....	9
<b>11 Test report</b> .....	<b>9</b>
<b>Annex A (informative) Precision</b> .....	<b>11</b>
<b>Annex B (informative) Guidance for using precision results</b> .....	<b>13</b>
<b>Annex C (normative) Calibration schedule</b> .....	<b>14</b>
<b>Bibliography</b> .....	<b>17</b>

## Foreword

ISO (the International Organization for Standardization) is a worldwide federation of national standards bodies (ISO member bodies). The work of preparing International Standards is normally carried out through ISO technical committees. Each member body interested in a subject for which a technical committee has been established has the right to be represented on that committee. International organizations, governmental and non-governmental, in liaison with ISO, also take part in the work. ISO collaborates closely with the International Electrotechnical Commission (IEC) on all matters of electrotechnical standardization.

The procedures used to develop this document and those intended for its further maintenance are described in the ISO/IEC Directives, Part 1. In particular the different approval criteria needed for the different types of ISO documents should be noted. This document was drafted in accordance with the editorial rules of the ISO/IEC Directives, Part 2 (see [www.iso.org/directives](http://www.iso.org/directives)).

Attention is drawn to the possibility that some of the elements of this document may be the subject of patent rights. ISO shall not be held responsible for identifying any or all such patent rights. Details of any patent rights identified during the development of the document will be in the Introduction and/or on the ISO list of patent declarations received (see [www.iso.org/patents](http://www.iso.org/patents)).

Any trade name used in this document is information given for the convenience of users and does not constitute an endorsement.

For an explanation on the meaning of ISO specific terms and expressions related to conformity assessment, as well as information about ISO's adherence to the World Trade Organization (WTO) principles in the Technical Barriers to Trade (TBT) see the following URL: [www.iso.org/iso/foreword.html](http://www.iso.org/iso/foreword.html).

The committee responsible for this document is ISO/TC 45, *Rubber and rubber products*, Subcommittee SC 2, *Testing and analysis*.

This third edition cancels and replaces the second edition (ISO 4666-3:2010), [5.1.2](#) of which has been technically revised.

A list of all parts in the ISO 4666 series can be found on the ISO website.

## Introduction

One major consequence of the internal heat generation of rubber under a flexing compression is the development of an elevated temperature in the rubber. This document provides for the measurement of the temperature rise.

Under particularly severe heat generation and temperature rise conditions, internal rupture of the test piece can occur with fatigue failure. Provision is also made for the measurement of resistance to this type of fatigue.

The test is conducted under conditions of a selected static pre-stress or compression and a selected cyclic strain of constant maximum amplitude imposed upon the pre-stressed test piece.



# Rubber, vulcanized — Determination of temperature rise and resistance to fatigue in flexometer testing —

## Part 3: Compression flexometer (constant-strain type)

**WARNING 1** — Persons using this document should be familiar with normal laboratory practice. This document does not purport to address all of the safety problems, if any, associated with its use. It is the responsibility of the user to establish appropriate safety and health practices and to ensure compliance with any national regulatory conditions.

**WARNING 2** — Certain procedures specified in this document might involve the use or generation of substances, or the generation of waste, that could constitute a local environmental hazard. Reference should be made to appropriate documentation on safe handling and disposal after use.

### 1 Scope

This document specifies the flexometer test with constant-strain amplitude for the determination of the temperature rise and resistance to fatigue of vulcanized rubber. The flexometer specified is known as the Goodrich flexometer, but any other apparatus giving equivalent performance can be used.

This document gives directions for carrying out measurements which make possible predictions regarding the durability of rubbers in finished articles subject to dynamic flexing in service, such as tyres, bearings, supports, V-belts, and cable-pulley insert rings. However, owing to the wide variations in service conditions, no simple correlation between the accelerated tests described in the various parts of this document and service performance can be assumed.

The method is not recommended for rubber having a hardness greater than 85 IRHD.

### 2 Normative references

The following documents are referred to in the text in such a way that some or all of their content constitutes requirements of this document. For dated references, only the edition cited applies. For undated references, the latest edition of the referenced document (including any amendments) applies.

ISO 48, *Rubber, vulcanized or thermoplastic — Determination of hardness (hardness between 10 IRHD and 100 IRHD)*

ISO 23529, *Rubber — General procedures for preparing and conditioning test pieces for physical test methods*

ISO 18899:2013, *Rubber — Guide to the calibration of test equipment*

### 3 Terms and definitions

For the purposes of this document, the terms and definitions given in ISO 4666-1 apply.

ISO and IEC maintain terminological databases for use in standardization at the following addresses:

— IEC Electropedia: available at <http://www.electropedia.org/>

— ISO Online browsing platform: available at <http://www.iso.org/obp>

## 4 Principle

A specified compressive load is applied to a test piece through a lever system having high inertia, while imposing on the test piece an additional high-frequency cyclic compression of specified amplitude. Measurements are made of the increase in temperature at the base of the test piece with a thermocouple which provides a relative indication of the heat generated in flexing the test piece and of the number of cycles which produces fatigue breakdown.

With the test piece subject to a constant applied load or to a constant initial compression during the test, continuous measurement is made of the change in height of the test piece. The compression set of the test piece is measured after testing.

## 5 Apparatus

### 5.1 Flexometer

#### 5.1.1 General description

The essential parts of the apparatus are shown in [Figure 1](#).

The test piece is placed between anvils faced with a thermal insulating material. The top anvil is connected to an adjustable eccentric usually driven at an oscillation rate of  $30 \text{ Hz} \pm 0,2 \text{ Hz}$ .

An anvil is sometimes called a “plate”. However, do not confuse “anvil” with the plate described in [Clause 7](#).

The load is applied by means of a lever resting on a knife edge. The moment of inertia of the lever system is increased and its natural frequency reduced by suspending masses of 24 kg at each end of the lever system. The lower anvil can be raised or lowered relative to the lever by means of a calibrated micrometer device. This device permits the lever system to be maintained in a horizontal position during the test as determined by a pointer and a reference mark on the end of the bar.

The increase in temperature at the base of the test piece is determined by means of a thermocouple placed at the centre of the bottom anvil.

#### 5.1.2 Detailed description

The apparatus (see [Figure 1](#)) consists of a balance beam (6) which can be locked in its horizontal position by means of a steel pin. The beam is provided with masses of 24 kg (8) at both ends. The distance between the knife edge supporting the beam and the edges supporting the masses is  $288 \text{ mm} \pm 0,5 \text{ mm}$ . An equivalent inertial system can be used.

The test piece (2) is placed upon an anvil (3) on one arm of the balance beam. The distance of the test piece support (10) from the fulcrum is  $127 \text{ mm} \pm 0,5 \text{ mm}$ . On the other side of the balance beam, additional masses (7) are placed in order to apply a load to the test piece. The desired weights are 11 kg or 22 kg which correspond to a pre-stress of  $1,0 \text{ MPa} \pm 0,03 \text{ MPa}$  or  $2,0 \text{ MPa} \pm 0,06 \text{ MPa}$ , respectively.

The test piece (2) is placed between the anvils (1 and 3), which are made of a thermal insulating material having a thermal conductivity of not more than  $0,28 \text{ W/(m}\cdot\text{K)}$  or, equivalently,  $0,24 \text{ kcal/(h}\cdot\text{m }^\circ\text{C)}$ . Phenolic hardpaper can be used for this purpose. In the centre of the lower anvil, a thermocouple, for example, iron-constantan, is attached for temperature measurement. The sensing point of the thermocouple shall be in contact with the test piece. The sensitivity of the thermocouple shall be  $\pm 0,5 \text{ }^\circ\text{C}$ .

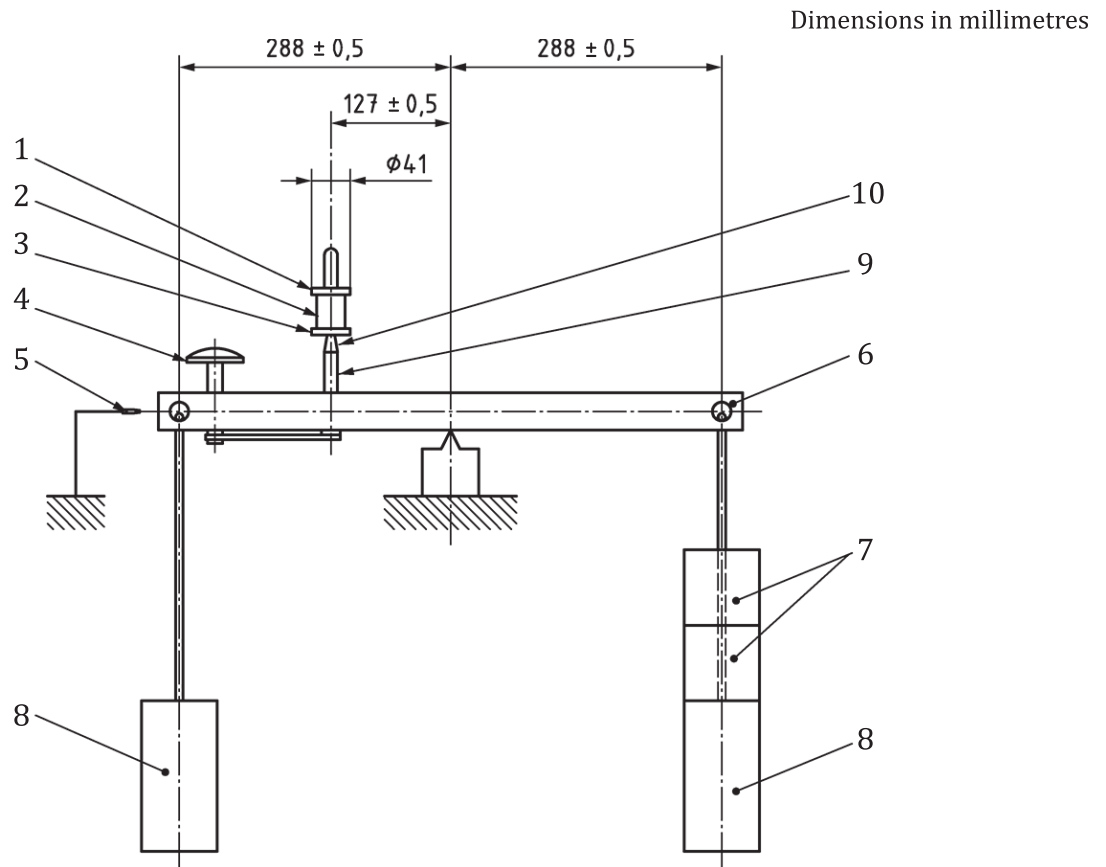

**Key**

1	upper anvil	6	balance beam
2	test piece	7	additional masses
3	lower anvil	8	masses
4	micrometer screw	9	screw
5	pointer	10	test piece support

**Figure 1 — Compression flexometer (constant-strain type) — General arrangement**

Means shall be provided for measuring the decrease in height of the test piece, as the test proceeds, with an accuracy of 0,1 mm. For this purpose, the distance between the lower and upper anvils can be varied by means of a calibrated micrometer device until it returns to the horizontal position, which can be recognized by a mark on the balance beam and a pointer (5) on the casing. The adjustment device consists of a micrometer screw (4) which, by means of a chain and sprocket-wheel drive, moves the screw (9) up or down without rotating the lower anvil (3). The degree of adjustment is read from the micrometer screw (4). The centre point of the upper anvil (1) remains in the same position. The upper anvil (1) is connected through a guide bearing to an eccentric which can be set to the desired stroke in a range from 4,45 mm to 6,35 mm and is driven by a motor at  $30 \text{ Hz} \pm 0,2 \text{ Hz}$ .

[Figure 2](#) shows a heating chamber. The test piece (7) with the supporting anvils is located in the chamber, the temperature of which can be maintained to within  $\pm 1 \text{ }^\circ\text{C}$  of a test temperature generally in the range  $40 \text{ }^\circ\text{C}$  to  $100 \text{ }^\circ\text{C}$ . The chamber shall have the following dimensions:

- width 100 mm to 220 mm;
- depth 130 mm to 250 mm;
- height approximately 230 mm.

The bottom of the chamber shall be situated  $25 \text{ mm} \pm 2 \text{ mm}$  above the balance beam (9).

A thermocouple of the same type as that used in the lower anvil (8) shall be used for measurement of the temperature in the chamber. The thermocouple shall be positioned at a distance of 6 mm to 9 mm towards the right-hand side behind the rear edge of the anvil and at a height midway between the anvils. A length of at least 100 mm of the thermocouple wire shall be within the chamber.

The air circulation within the chamber is provided by a radial fan (4) of 75 mm diameter, operating at a rotational frequency of 25 Hz to 28 Hz. The air intake shall have a diameter of 60 mm. The air outlet (5) shall measure 40 mm × 45 mm. The grid shelf for supporting the test piece during conditioning (2) shall be fitted 10 mm ± 2 mm above the bottom of the chamber.

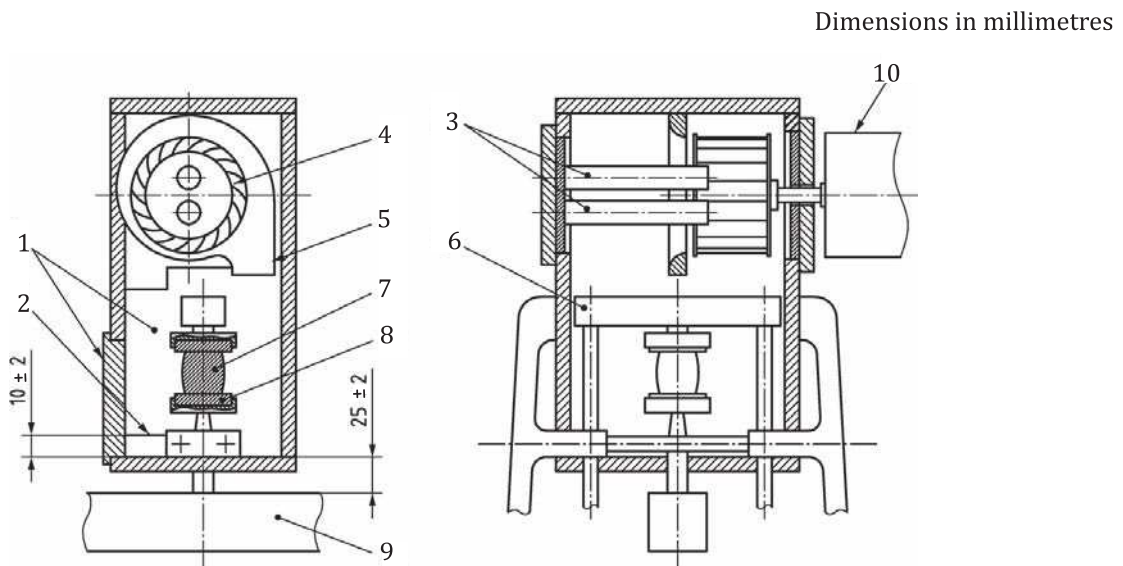

**Key**

- |   |  |
|---|--|
| 1 heating chamber with door                                 | 6 crossbar with lifting rods and upper anvil |
| 2 grid shelf for supporting test pieces during conditioning | 7 test piece                                 |
| 3 heating elements  | 8 lower anvil with thermocouple              |
| 4 radial fan  | 9 balance beam                               |
| 5 air outlet  | 10 motor of radial fan                       |

**Figure 2 — Example of a heating chamber**

**5.2 Measuring gauge**

The gauge for measuring the height and diameter of test pieces shall conform to the requirements of ISO 23529.

**5.3 Timer**

A stopwatch or other similar device shall be used.

**6 Calibration**

The test apparatus shall be calibrated in accordance with the schedule given in [Annex C](#).

**7 Test piece**

The test piece shall be cylindrical in shape, having a diameter of 17,8 mm ± 0,15 mm and a height of 25 mm ± 0,25 mm.

The standard method of preparing the test piece shall be the direct moulding of the cylinder. It is suggested, for the purpose of uniformity and closer tolerance in the moulded test piece, that the dimensions of the mould be specified and shrinkage compensated for therein. A plate cavity of thickness  $25,4 \text{ mm} \pm 0,05 \text{ mm}$  and diameter  $18,00 \text{ mm} \pm 0,05 \text{ mm}$ , having overflow cavities at both top and bottom when combined with two end plates, provides one type of suitable mould.

An alternative method of preparing the test piece is to cut from a vulcanized slab of the required thickness. The vulcanized thickness shall be such that buffing is not required.

The circular die used for cutting the test piece shall have an inside diameter of  $17,8 \text{ mm} \pm 0,03 \text{ mm}$ . In cutting the test piece, the die shall be suitably rotated in a drill press or similar device and lubricated by means of a soap solution. A minimum distance of 13 mm shall be maintained between the cutting edge of the die and the edge of the slab. The cutting pressure shall be as light as possible to minimize cupping or taper in the diameter of the test piece.

It should be recognized that equal time and temperature used for both moulded and slab test pieces do not produce an equivalent state of vulcanization in the two types of test piece. A higher degree of vulcanization is obtained in the moulded test piece. Adjustments, preferably in the time of cure, should be taken into consideration if comparisons between the two types of test piece are to be considered valid.

## 8 Test conditions

The conditions specified in [Table 1](#) are normally employed in flexometer tests with constant-strain amplitude.

**Table 1 — Test conditions**

Conditions	Nominal value
Chamber temperature	$55 \text{ °C} \pm 1 \text{ °C}$ or $100 \text{ °C} \pm 1 \text{ °C}$
Stroke (double amplitude)	4,45 mm, 5,71 mm or 6,35 mm
Pre-stress on test piece <sup>a</sup>	1,0 MPa or 2,0 MPa
<sup>a</sup> A pre-stress of 1,0 MPa is equivalent to a weight on the balance beam of 11 kg; a pre-stress of 2,0 MPa is equivalent to a weight of 22 kg.	

Tests with the heating chamber removed are referred to as “room temperature” tests, or tests at standard laboratory temperature. The standard laboratory temperature used shall be specified in the test report.

For the measurement of temperature rise, a chamber temperature of either  $55 \text{ °C}$  or  $100 \text{ °C}$  shall be selected with a stroke of 4,45 mm or 5,71 mm. Any of these choices of temperature and stroke can be used with a pre-stress of either 1,0 MPa or 2,0 MPa on the test piece. These choices ordinarily give a temperature rise that is essentially at equilibrium after the normal test duration of 25 min. However, test times longer than 25 min can be selected, if desired, for special test purposes.

For measurement of the fatigue properties of rubber, more severe test conditions are needed. Specifically, strokes of 5,71 mm and 6,35 mm are recommended with the higher pre-stress on the balance beam. Selection of the more severe conditions avoids excessive test durations for each test piece.

In general, for medium hardness rubbers that have ordinary temperature rise characteristics, a pre-stress of 1,0 MPa, a stroke of 5,71 mm and a chamber temperature of  $55 \text{ °C}$  or  $100 \text{ °C}$  is recommended.

The same test conditions shall be maintained throughout a series of tests intended for comparison of a group of compounds.

## 9 Procedure

### 9.1 Preparation of flexometer

Locate the machine on a firm foundation. Adjust the leveling screw in the base to bring the machine into a level position in all directions at a point just to the rear of the fulcrum of the loading lever. With the loading lever locked in place with the pin, place a level on the lever bar and verify the level setting.

Adjust the eccentric to give a stroke or a double amplitude of  $4,45 \text{ mm} \pm 0,03 \text{ mm}$ . This is best accomplished by means of a dial micrometer resting on either the crossbar of the upper anvil or by means of adapters attached to the loading arm of the eccentric.

The 4,45 mm stroke is selected as the standard for calibration purposes. When strokes other than 4,45 mm are to be used, the displacement of the lower anvil should be maintained within the tolerance specified for its height above the loading lever.

Raise the top anvil as far as the eccentric permits by its rotation. Place a calibrating block of height  $25,0 \text{ mm} \pm 0,01 \text{ mm}$  on the lower anvil.

A suitable block may be made from brass having a diameter of 17,8 mm. The end to be placed on the lower anvil should be counter-bored for clearance of the thermocouple disc.

Raise the anvil by means of the micrometer until the bottom side of the metal cup holding the thermocouple is  $67 \text{ mm} \pm 3 \text{ mm}$  above the top of the loading lever. The loading lever shall be in the locked position.

Adjust the crossbar of the upper anvil, maintaining a parallel setting with the lower anvil and a firm contact with the calibrating block. The micrometer shall now be set at zero. This could require disengagement of the gear train nearest the vernier scale of the micrometer.

Remove the calibrating block and recheck the stroke or double amplitude for the 4,45 mm setting. Set the pointer on the mark at the end of the lever bar. This establishes the level position.

Remove the locking pin from the loading lever and gently oscillate the lever system to determine the point of rest. If the bar does not come to rest in approximately the level position, slowly return it to its level position and release. If movement from the level position is observed, add or remove a mass to or from the required inertia mass to obtain a balance.

### 9.2 Test procedure

#### 9.2.1 General

Check the machine for proper adjustment (see [9.1](#)) and the required test conditions (see [Clause 8](#)). Place the necessary masses on the rear hanger to give the desired load.

If a stroke other than 4,45 mm is desired, a new zero setting is required on the micrometer after adjusting the eccentric to the new stroke. Proceed as outlined in [9.1](#) to obtain the zero setting.

For elevated temperatures requiring the use of the heating chamber, allow a minimum of 2 h for preheating of the apparatus and the attainment of equilibrium prior to the start of test. Maintain the lower anvil at the zero setting, that is, 67 mm above the loading lever during the conditioning period.

Measure and record the height of the test piece. Then measure its hardness in accordance with ISO 48.

When the heating chamber is to be used, place the test piece in the chamber on the grid shelf and condition for a minimum of 30 min before the start of test.

Before starting the test, the lower anvil temperature and the ambient test temperature shall be in equilibrium. With the upper anvil or crossbar in its highest position, lower the bottom anvil and quickly position the test piece thereon, inverting its position from that used during the conditioning period.

The thermocouple in the lower anvil stabilizes at a temperature approximately 6 °C lower in an ambient chamber temperature of 100 °C. This is the base temperature above which the temperature rise is measured. Any momentary drop in the base temperature at the start of the test should be disregarded.

Raise the lower anvil by means of the micrometer until a firm contact is established with the upper anvil. Remove the locking pin and apply the load. Then advance the micrometer until the beam is again restored to its original level position as determined by the indicator.

If the test piece had an original height of exactly 25,0 mm, then the micrometer reading shall be used without correction for the compression height.

If the original height of the test piece is less than 25,0 mm, then the difference shall be subtracted from the micrometer reading. For a test piece of height greater than 25,0 mm, the difference shall be added to the micrometer reading.

For a smooth start, restore the pin to the locked position of the loading lever, and back off the micrometer three to four turns. Then loosen the pin, start the machine, and remove the pin completely. Immediately restore the beam to the level position by means of the micrometer and record the reading. Subject this reading to the same corrections as used for the static measurements.

If the initial running deflection is less than one half of the impressed stroke or does not exceed this value within 1 min or 2 min of the start, an unreliable and misleading temperature rise is obtained. The loading lever shall be maintained in a level position throughout the test.

If a recorder is not used to obtain a continuous temperature rise curve, obtain a series of measurements using a suitable potentiometer. Plot the readings and draw the temperature rise curve.

### **9.2.2 Determination of temperature rise and of compression set**

To determine the temperature rise and the compression set, continue the test for the normal test duration of 25 min, provided that no premature failure occurs in the test piece. Longer test durations can be required if steady-state conditions are always to be attained. At the end of the test, remove the test piece from the apparatus and after storage for 1 h to cool to standard laboratory temperature, measure the height,  $h_e$ .

### **9.2.3 Determination of fatigue resistance**

To determine the fatigue life, continue the test until breakdown occurs. Incipient breakdown is revealed by an irregularity in the temperature curve (sudden temperature rise) or by a marked increase in creep. After ending the test, cut the test piece horizontally midway in the height direction and visually confirm damage in the form of initial porosity, softening or other changes.

If no breakdown occurs, more severe testing conditions shall be selected (see [Clause 8](#)).

### **9.2.4 Determination of creep**

Determine creep by measuring the test piece height 6 s after the start of the cyclic loading and then after a specified test duration.

## 10 Expression of results

### 10.1 Temperature rise

The temperature rise,  $\Delta\theta$ , expressed in degrees Celsius, is given by [Formula \(1\)](#):

$$\Delta\theta = \theta_{25} - \theta_0 \quad (1)$$

where

$\theta_{25}$  is the temperature, in degrees Celsius, of the test piece after the test duration;

$\theta_0$  is the temperature, in degrees Celsius, of the test piece at the beginning of the test.

### 10.2 Creep

The creep,  $F_t$ , expressed as a percentage, after the test duration,  $t$ , is defined by [Formula \(2\)](#):

$$F_t = \frac{h_6 - h_t}{h_0} \times 100 \quad (2)$$

where

$h_6$  is the test piece height, in millimetres, determined 6 s after the start of cyclic loading;

$h_t$  is the test piece height, in millimetres, determined after the test duration,  $t$ ;

$h_0$  is the original height, in millimetres, of the test piece in the unloaded condition.

The test piece height shall be measured as described previously. The balance beam shall be set to its zero position after not more than 6 s of running time. For the original height,  $h_0$ , the nominal value  $h_0 = 25$  mm shall be used, since it is a requirement that the differences be within the tolerance range of  $\pm 0,2$  mm.

NOTE [Formula \(2\)](#) differs from the usual definition of creep. In other cases, creep is expressed relative to the initial deformation:

$$F_t = \frac{h_6 - h_t}{h_0 - h_6}$$

[Formula \(2\)](#) has the advantage that there is no need to recalculate with reference to the height  $h_6$  in the loaded condition. The quantity  $(h_6 - h_t)/h_0$  is also easily read on the micrometer or recorded by an automatic compensator, since the original height  $h_0$  is considered to be constant (within the tolerance range of  $\pm 0,2$  mm).

### 10.3 Compression set

The compression set,  $S$ , expressed as a percentage, is given by [Formula \(3\)](#):

$$S = \frac{h_0 - h_e}{h_0} \times 100 \quad (3)$$

where

$h_0$  is the original height, in millimetres, of the test piece in the unloaded condition;

$h_e$  is the final height, in millimetres, of the test piece after conditioning for 1 h in the unloaded condition.

### 10.4 Fatigue life

The fatigue life is expressed as the number of cycles,  $N$ , to breakdown or failure of the test piece. Breakdown or the failure criterion shall be clearly defined and the definition cited.

## 11 Test report

The test report shall include at least the following information:

- a) sample details:
  - 1) full description of the sample and its origin;
  - 2) method of preparation of test piece from the sample, e.g. whether moulded or cut or taken from finished products;
- b) test method:
  - 1) test method used, a reference to this document, i.e. ISO 4666-3;
  - 2) test procedure used;
  - 3) original height of test piece and, in case of deviation from standard dimensions, the diameter;
  - 4) hardness of test piece;
- c) test details:
  - 1) standard laboratory temperature;
  - 2) time and temperature of conditioning prior to test;
  - 3) pre-stress;
  - 4) stroke;
  - 5) heating chamber temperature;
  - 6) any departures from the procedures specified in this document;
- d) test results:
  - 1) number of test pieces used;
  - 2) for the measurement of temperature rise: the test duration, the individual values and the mean value;

- 3) for the measurement of creep: the test duration, the individual values and the mean value, expressed as a percentage;
  - 4) for the measurement of compression set: the test duration, the individual values and the mean value, expressed as a percentage;
  - 5) for the measurement of fatigue resistance: the criterion of fatigue failure, and the number of cycles to this selected failure point, expressed as individual values and mean values;
- e) date of test.



## Annex A (informative)

### Precision

#### A.1 General

A type 1 interlaboratory test programme (ITP) and the subsequent precision calculations to express repeatability and reproducibility were performed in accordance with ISO/TR 9272. [Annex B](#) gives guidance on the use of repeatability and reproducibility results.

NOTE The ITP was also organized for constant-stress flexometer testing in accordance with ISO 4666-4 at the same time.

#### A.2 Precision details

**A.2.1** The ITP was organized in 2001. Prepared test pieces were sent out to all participating laboratories using three compounds (of types NR, SBR and CR), the formulations of which are shown in [Table A.1](#). The test was carried out under the following test conditions (see [Clause 8](#)).

Chamber temperature:	55 °C (condition for a minimum 30 min)
Pre-stress:	1,0 MPa
Stroke:	4,45 mm
Frequency:	30 Hz
Test duration:	25 min

**A.2.2** The tests were conducted on two test pieces of each rubber on each of two days, separated by one week. Temperature rise, in degrees Celsius, creep, expressed as a percentage, and compression set, expressed as a percentage, were measured.

**A.2.3** A total of eight laboratories participated in this ITP.

Table A.1 — Formulation of rubber compounds

Substance	NR	SBR	CR
NR (RSS#1)	100	—	—
SBR1502	—	100	—
CR (sulfur-modified type)	—	—	100
HAF carbon black (N330)	35	50	25
Zinc oxide	5	3	5
Magnesium oxide	—	—	4
Stearic acid	2	1	0,5
Antioxidant 6PPD <sup>a</sup>	2	2	2
Antioxidant TMQ <sup>b</sup>	2	2	—
Wax	1	1	—
Accelerator TBBS <sup>c</sup>	0,7	1	—
Sulfur	2,25	1,75	—
Total	149,95	161,75	136,5
<sup>a</sup> <i>N</i> -(1,3-Dimethylbutyl)- <i>N'</i> -phenyl- <i>p</i> -phenylenediamine. <sup>b</sup> Polymerized 2,2,4-trimethyl-1,2-dihydroquinoline. <sup>c</sup> <i>N-tert</i> -Butyl-2-benzothiazolesulfenamide.			

### A.3 Precision results

The calculation of precision was made, in accordance with the decision tree diagram for ITP data analysis of ISO/TR 9272:2005, Figure 1, by eliminating abnormal values for Option 1. The precision results are given in [Table A.2](#).

Table A.2 — Constant-strain flexometer testing

Property	Test rubber	Mean value	Within laboratory		Between laboratories	
			<i>r</i>	( <i>r</i> )	<i>R</i>	( <i>R</i> )
Temperature rise, °C	NR	12,41	1,12	9,73	4,86	39,15
	SBR	27,59	1,42	5,15	10,12	36,68
	CR	20,58	2,38	11,58	14,69	71,38
Creep, %	NR	7,13	0,52	7,28	20,41	286,1
	SBR	0,55	0,51	92,38	0,77	140,6
	CR	0,38	0,28	73,13	1,86	484,5
Compression set, %	NR	2,48	0,25	10,10	1,33	53,7
	SBR	3,27	0,45	13,73	2,33	71,2
	CR	1,16	0,24	20,49	0,77	66,5
<i>r</i> is the repeatability, in measurement units; ( <i>r</i> ) is the repeatability, expressed as a percentage (relative); <i>R</i> is the reproducibility, in measurement units; ( <i>R</i> ) is the reproducibility, expressed as a percentage (relative).						

## Annex B (informative)

### Guidance for using precision results

**B.1** The general procedure for using precision results is described in [B.2](#) to [B.4](#), with the quantity  $|x_1 - x_2|$  designating a modulus, i.e. an absolute difference in any two measurement values without regard to sign.

**B.2** Enter the appropriate precision table (for whatever test parameter is being considered) at an average value (of the measured parameter) nearest to the “test” data average under consideration. This line gives the applicable  $r$ ,  $(r)$ ,  $R$  or  $(R)$  for use in the decision process.

**B.3** With these,  $r$ , and  $(r)$  values, the following general repeatability statements may be used to make decisions.

**B.3.1** For a modulus: the difference  $|x_1 - x_2|$  between two test (value) averages, found on nominally identical material samples under normal and correct operation of the test procedure, will exceed the tabulated repeatability,  $r$ , on average not more than once in 20 cases.

**B.3.2** For a percentage difference between two test (value) averages: the percentage difference

$$\frac{|x_1 - x_2|}{0,5(x_1 + x_2)} \times 100$$

between two test values, found on nominally identical material samples under normal and correct operation of the test procedure, will exceed the tabulated repeatability,  $(r)$ , on average not more than once in 20 cases.

**B.4** With these  $R$  and  $(R)$  values, the following general reproducibility statements may be used to make decisions.

**B.4.1** For an absolute difference: the absolute difference  $|x_1 - x_2|$  between two independently measured test (value) averages, found in two laboratories using normal and correct test procedures on nominally identical material samples, will exceed the tabulated reproducibility,  $R$ , not more than once in 20 cases.

**B.4.2** For a percentage difference between two test (value) averages: the percentage difference

$$\frac{|x_1 - x_2|}{0,5(x_1 + x_2)} \times 100$$

between two independently measured test (value) averages, found in two laboratories using normal and correct test procedures on nominally identical material samples, will exceed the tabulated reproducibility,  $(R)$ , not more than once in 20 cases.

## Annex C (normative)

### Calibration schedule

#### C.1 Inspection

Before any calibration is undertaken, the condition of the items to be calibrated shall be ascertained by inspection and recorded on any calibration report or certificate. It shall be reported whether calibration is made in the “as-received” condition or after rectification of any abnormality or fault.

It shall be ascertained that the apparatus is, in general, fit for the intended purpose, including any parameters specified as approximate and for which the apparatus does not therefore need to be formally calibrated. If such parameters are liable to change, then the need for periodic checks shall be written into the detailed calibration procedures.

#### C.2 Schedule

Verification or calibration of the test apparatus is a requirement of this document. The frequency of calibration and the procedures used are, unless otherwise stated, at the discretion of the individual laboratory, using ISO 18899 for guidance.

The calibration schedule given in [Table C.1](#) has been compiled by listing all of the parameters specified in the test method, together with the specified requirement. A parameter and requirement can relate to the main test apparatus, part of that apparatus or to an ancillary apparatus necessary for the test.

For each parameter, a calibration procedure is indicated by reference to ISO 18899, to another publication or to a procedure particular to the test method which is detailed (whenever a more specific or detailed calibration procedure than that specified in ISO 18899 is available, it shall be used in preference).

The verification frequency for each parameter is given by a code letter.

The code letters used in the calibration schedule are:

- N Initial verification only
- S Standard interval as given in ISO 18899
- U In use

In addition to the items listed in [Table C.1](#), use of the following is implied, all of which need calibrating in accordance with ISO 18899:

- a timer;
- a thermometer for monitoring the conditioning and test temperatures;
- instruments for determining the dimensions of the test pieces.

Table C.1 — Calibration frequency schedule

Parameter	Requirement	Subclause in ISO 18899:2013	Verification frequency guide	Notes
Machine installation	Firm foundation <sup>a</sup>		N	
Anvils	Faced with thermal insulator <sup>a</sup>		N	
Masses on lever	Approximately 24 kg	22.2	N	
Micrometer	Calibrated	15.1	N	
Horizontal position	Pointer and reference mark	15.1	N	
Distance between knife edge and supporting mass	288 mm ± 0,5 mm	15.2	N	Equivalent inertial system permitted
Distance between knife edge and screw	127 mm ± 0,5 mm	15.2	N	
Heating chamber — width — depth — height	100 mm to 220 mm 130 mm to 250 mm approximately 230 mm	15.2	N	See <a href="#">Figure 2</a>
Radial fan	φ 75 mm	15.2	N	
Rotational frequency	25 Hz to 28 Hz	23.3	N	
Air intake	φ 60 mm	15.2	N	
Air outlet	40 mm × 45 mm	15.2	N	
Grid shelf	10 mm ± 2 mm above bottom of chamber	15.2	N	See <a href="#">Figure 2</a>
Mould	φ 18,0 mm ± 0,05 mm height 25,4 mm ± 0,05 mm	15.2 15.2	S S	With overflow cavities top and bottom
Circular die diameter	17,8 mm ± 0,03 mm	15.2	S	Die to be rotated and lubricated
Oscillation rate	30 Hz ± 0,2 Hz	23.3	S	
Weights giving pre-stress	11 kg or 22 kg	22.2	S	
Thermocouple sensitivity	Centre of bottom anvil in contact with test piece ±0,5 °C	Clause 18	S	
Stroke for calibration	4,45 mm ± 0,03 mm	15.1	S	
Temperature control	±1 °C	Clause 18	S	
Thermocouple for chamber	Same type as bottom anvil	Clause 18	S	
Calibrating block height	25 mm ± 0,01 mm	15.2	S	e.g. brass φ 17,8 mm
Bottom of chamber	25 mm ± 2 mm above the balance beam	15.2	U	See <a href="#">Figure 2</a>
Position of thermocouple for chamber	6 mm to 9 mm towards right-hand side behind rear edge of anvil	15.2	U	
Adjust thermocouple/loading lever height to	67 mm ± 3 mm	15.2	U	
NOTE Test conditions specified in the text are not included in this table as they are redundant.				
<sup>a</sup> Requirement to be confirmed but no measurement.				

**Table C.1** (continued)

<b>Parameter</b>	<b>Requirement</b>	<b>Subclause in ISO 18899:2013</b>	<b>Verification frequency guide</b>	<b>Notes</b>
Crossbar of upper anvil	Parallel lower anvil firm contact with block <sup>a</sup>		U	
Micrometer setting	Zero <sup>a</sup>		U	
Pointer setting	To the mark indicating level <sup>a</sup>		U	
Check the rest position	Add or remove weights to obtain balance <sup>a</sup>		U	

NOTE Test conditions specified in the text are not included in this table as they are redundant.

<sup>a</sup> Requirement to be confirmed but no measurement.

## Bibliography

- [1] ISO 4666-1, *Rubber, vulcanized — Determination of temperature rise and resistance to fatigue in flexometer testing — Part 1: Basic principles*
- [2] ISO/TR 9272:2005, *Rubber and rubber products — Determination of precision for test method standards*

