

---

---

**Rubber compounding ingredients —  
Carbon black — Determination of specific  
surface area by nitrogen adsorption  
methods — Single-point procedures**

*Ingrédients de mélange du caoutchouc — Noir de carbone —  
Détermination de la surface spécifique par méthodes par adsorption  
d'azote — Modes opératoires à un point de mesure*





**COPYRIGHT PROTECTED DOCUMENT**

© ISO 2012

All rights reserved. Unless otherwise specified, no part of this publication may be reproduced or utilized in any form or by any means, electronic or mechanical, including photocopying and microfilm, without permission in writing from either ISO at the address below or ISO's member body in the country of the requester.

ISO copyright office  
Case postale 56 • CH-1211 Geneva 20  
Tel. + 41 22 749 01 11  
Fax + 41 22 749 09 47  
E-mail [copyright@iso.org](mailto:copyright@iso.org)  
Web [www.iso.org](http://www.iso.org)

Published in Switzerland

# Contents

Page

Foreword .....	iv
<b>1 Scope .....</b>	<b>1</b>
<b>2 Normative references .....</b>	<b>1</b>
<b>3 Method A, using Ni-Count-1 apparatus .....</b>	<b>1</b>
3.1 Principle .....	1
3.2 Reagents .....	2
3.3 Apparatus .....	2
3.4 Preparation of the sample .....	5
3.5 Test conditions .....	5
3.6 Procedure .....	6
3.7 Expression of results .....	11
3.8 Test report .....	12
<b>4 Method B, using an Areameter apparatus .....</b>	<b>12</b>
4.1 Principle .....	12
4.2 Reagents .....	12
4.3 Apparatus .....	12
4.4 Preparation of the test portion .....	14
4.5 Test conditions .....	15
4.6 Procedure .....	15
4.7 Expression of results .....	16
4.8 Test report .....	17
<b>5 Method C, using gas chromatography .....</b>	<b>18</b>
5.1 Principle .....	18
5.2 Reagents .....	18
5.3 Apparatus .....	18
5.4 Test conditions .....	19
5.5 Procedure .....	19
5.6 Expression of results .....	20
5.7 Test report .....	20
<b>6 Method D, using a Monosorb surface-area analyser .....</b>	<b>21</b>
6.1 Principle .....	21
6.2 Reagents .....	21
6.3 Apparatus .....	21
6.4 Initial installation .....	22
6.5 Test conditions .....	22
6.6 Calibration .....	22
6.7 Procedure .....	22
6.8 Expression of results .....	25
6.9 Test report .....	25
<b>Annex A (normative) Preparation of Areameter .....</b>	<b>27</b>

## Foreword

ISO (the International Organization for Standardization) is a worldwide federation of national standards bodies (ISO member bodies). The work of preparing International Standards is normally carried out through ISO technical committees. Each member body interested in a subject for which a technical committee has been established has the right to be represented on that committee. International organizations, governmental and non-governmental, in liaison with ISO, also take part in the work. ISO collaborates closely with the International Electrotechnical Commission (IEC) on all matters of electrotechnical standardization.

International Standards are drafted in accordance with the rules given in the ISO/IEC Directives, Part 2.

The main task of technical committees is to prepare International Standards. Draft International Standards adopted by the technical committees are circulated to the member bodies for voting. Publication as an International Standard requires approval by at least 75 % of the member bodies casting a vote.

Attention is drawn to the possibility that some of the elements of this document may be the subject of patent rights. ISO shall not be held responsible for identifying any or all such patent rights.

ISO 4652 was prepared by Technical Committee ISO/TC 45, *Rubber and rubber products*, Subcommittee SC 3, *Raw materials (including latex) for use in the rubber industry*.

This second edition of ISO 4652 cancels and replaces ISO 4652-1:1994, which has been technically revised. The revision includes the following changes:

- The number of the standard has been changed from ISO 4652-1 to ISO 4652, since there were no other parts.
- The title has been modified accordingly.
- A statement has been added to the scope that the multipoint method specified in ISO 18852 is the preferred method.
- The normative references in Clause 2 have been updated.
- The Ni-Count-1 apparatus used in method A is no longer available from the manufacturer. However, it has been decided to keep method A for those still using this apparatus. A note has been added at the beginning of Clause 3 to explain this.

# Rubber compounding ingredients — Carbon black — Determination of specific surface area by nitrogen adsorption methods — Single-point procedures

**WARNING** — Persons using this International Standard should be familiar with normal laboratory practice. This standard does not purport to address all of the safety problems, if any, associated with its use. It is the responsibility of the user to establish appropriate safety and health practices and to ensure compliance with any national regulatory conditions.

## 1 Scope

This International Standard specifies four methods for the determination of the specific surface area of types and grades of carbon black for use in the rubber industry:

- method A using the Ni-Count-1 apparatus (Clause 3);
- method B using the Areameter apparatus (Clause 4);
- method C using gas chromatography (Clause 5);
- method D using the Monosorb surface-area analyser (Clause 6).

Somewhat different results might be obtained from the four methods. The degassing procedure used differs from method to method, and it is important to investigate the possibility of correcting the results by using standard reference blacks.

The results might also differ from those obtained using the multipoint method specified in ISO 18852, which is the preferred method.

## 2 Normative references

The following referenced documents are indispensable for the application of this document. For dated references, only the edition cited applies. For undated references, the latest edition of the referenced document (including any amendments) applies.

ISO 1126, *Rubber compounding ingredients — Carbon black — Determination of loss on heating*

ISO 18852, *Rubber compounding ingredients — Determination of multipoint nitrogen surface area (NSA) and statistical thickness surface area (STSA)*

## 3 Method A, using Ni-Count-1 apparatus

**NOTE** Although the Ni-Count-1 apparatus is no longer being produced by the manufacturer, E.G. & G. Chandler Engineering, this method has been retained for the convenience of those who are still using this apparatus.

### 3.1 Principle

A test portion is degassed and weighed, then exposed to nitrogen at the temperature of liquid nitrogen. The amount of nitrogen adsorbed on to the carbon black surface at equilibrium is determined. From this value and the mass of the degassed test portion, the specific surface area is calculated.

## 3.2 Reagents

**3.2.1 Nitrogen**, in a cylinder, or another source of purified nitrogen of recognized analytical quality.

The nitrogen supply to the Ni-Count-1 apparatus (see 3.3.1) shall be controlled at a pressure of 70 kPa to 140 kPa. If nitrogen from a cylinder is used, the cylinder shall be fitted with a two-stage regulator capable of maintaining the outlet pressure within the specified range.

**3.2.2 Liquid nitrogen** (approximately 300 cm<sup>3</sup> are required for the determination).

**WARNING — Use caution. Gloves and safety glasses should be worn as the temperature of liquid nitrogen is –196 °C.**

## 3.3 Apparatus

**3.3.1 Ni-Count-1 specific surface area apparatus** (see Figures 1 and 2), or an equivalent one-point adsorption apparatus.

NOTE The Ni-Count-1 apparatus is no longer produced (see the note at the beginning of this clause).

**3.3.2 Heater and voltage-control device**, capable of maintaining a temperature of 300 °C ± 10 °C, for degassing the test portion.

NOTE The heater (see Figure 1) is furnished with the Ni-Count-1 apparatus.

**3.3.3 Vacuum pump**, capable of producing an ultimate pressure of  $(1,3 \times 10^{-2})$  Pa [ $(1 \times 10^{-4})$  mmHg].

**3.3.4 Dewar flask**, capacity approximately 265 cm<sup>3</sup> and height 145 mm.

This is supplied with the Ni-Count-1 apparatus.

**3.3.5 Nitrogen vapour pressure thermometer** (see Figure 2).

This is supplied with the Ni-Count-1 apparatus.

**3.3.6 Sample tubes** (see Figure 3).

The recommended volumes are given in Table 1.

**3.3.7 Stopcock grease or poly(chlorotrifluoroethylene) lubricant.**

This is supplied with the Ni-Count-1 apparatus.

**3.3.8 Fine glass wool.**

**3.3.9 Analytical balance**, accurate to 0,1 mg.

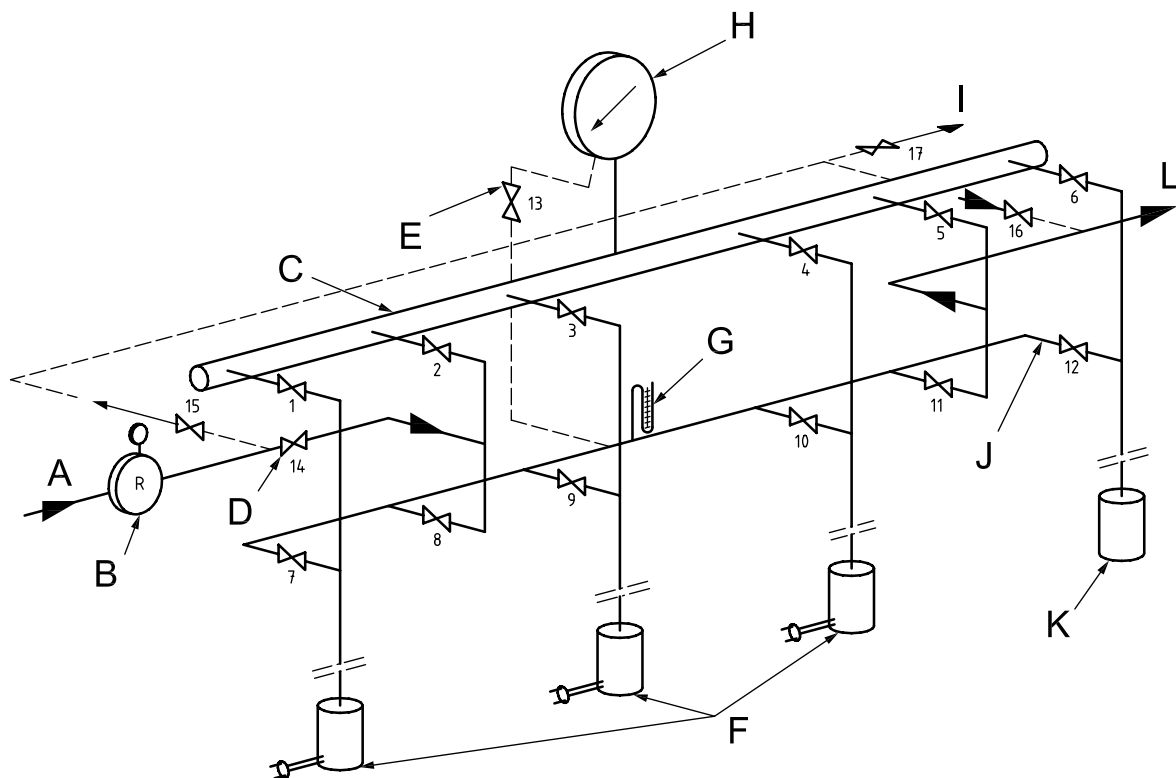

**Key**

- |   |  |   |   |
|---|--|---|---|
| A | nitrogen gas   | G | vacuum indicator  |
| B | flow regulator                                       | H | precision pressure gauge, 0 kPa to 103 kPa (0 mmHg to 775 mmHg) |
| C | calibrated-volume chamber and manifold               | I | to nitrogen vapour pressure thermometer                         |
| D | flow-control valve                                   | J | vacuum manifold   |
| E | line and valve for evacuating case of pressure gauge | K | Dewar flask with liquid nitrogen                                |
| F | electric heaters (see 3.3.2)                         | L | to vacuum pump  |

**Figure 1 — Ni-Count-1 apparatus with provision for four test portions**

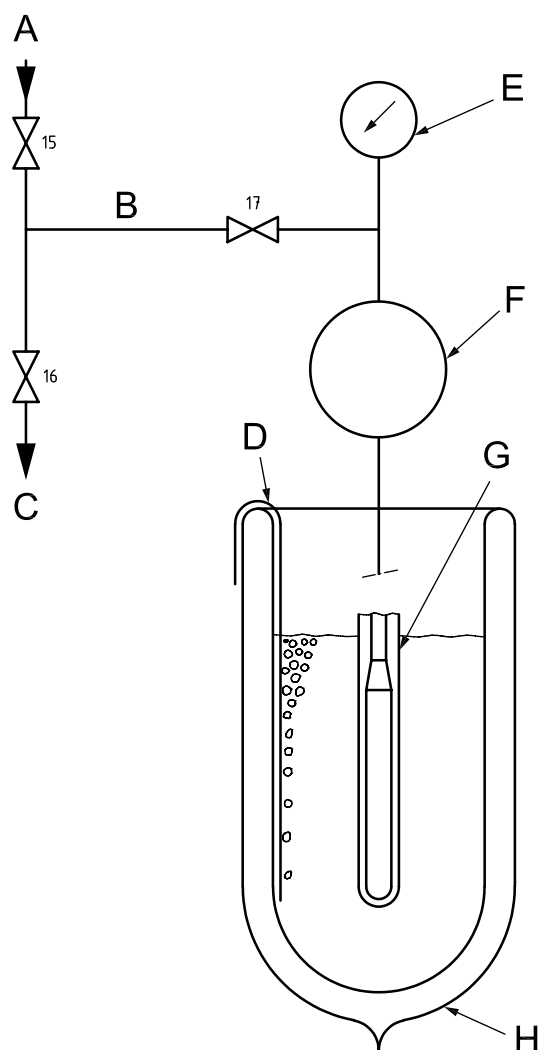

**Key**

- |   |  |
|---|--|
| A pure nitrogen                               | E precision pressure gauge, 0 kPa to 25 kPa (0 mmHg to 186 mmHg) |
| B filling connection                          | F volume chamber   |
| C to vacuum pump                              | G sensing element of thermometer                                 |
| D copper wire looped over edge of Dewar flask | H Dewar flask containing liquid nitrogen                         |

NOTE The system is filled with pure nitrogen to a pressure of 13 kPa to 20 kPa (100 mmHg to 150 mmHg).

**Figure 2 — Nitrogen vapour pressure thermometer**

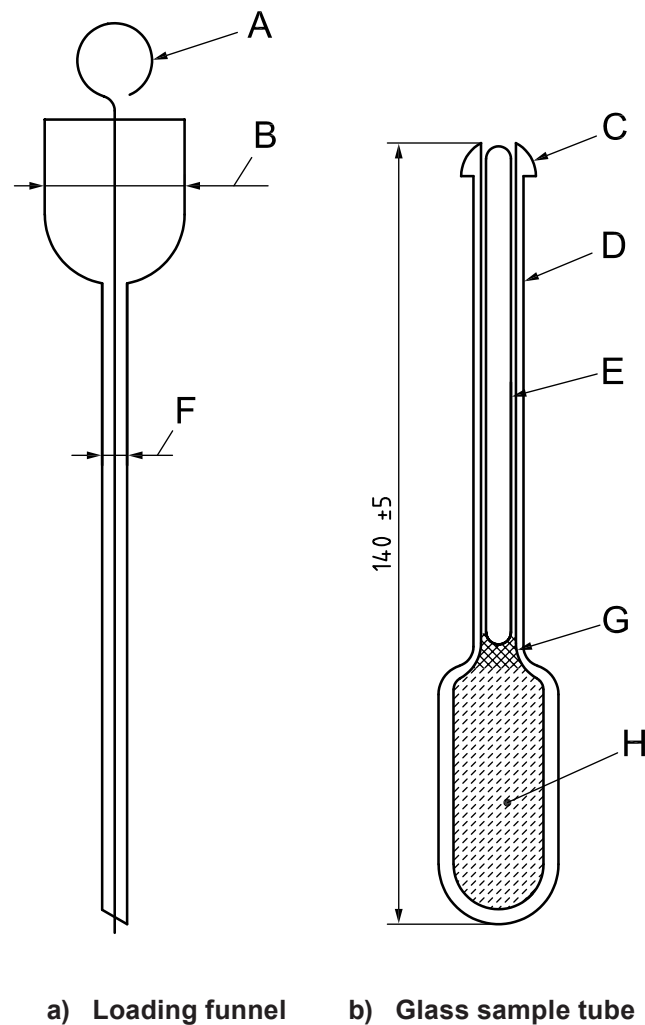

Dimensions in millimetres

**Key**

- |   |  |   |                       |
|---|--|---|-----------------------|
| A | stainless-steel wire   | F | outside diameter 5 mm |
| B | outside diameter 25 mm   | G | glass-wool plug       |
| C | 12/5 ball joint  | H | test portion          |
| D | tubing, outside diameter 8 mm, inside diameter 6 mm              |   |                       |
| E | filler rod or tubing, outside diameter 5 mm, sealed at both ends |   |                       |

**Figure 3 — Loading funnel and glass sample tube****3.4 Preparation of the sample**

Pellets of carbon black need not be crushed. Unagitated, unpelletized carbon black may be densified if desired.

**3.5 Test conditions**

The test should preferably be carried out in ambient conditions of either  $23\text{ °C} \pm 2\text{ °C}$  and  $(50 \pm 5)\%$  relative humidity or  $27\text{ °C} \pm 2\text{ °C}$  and  $(65 \pm 5)\%$  relative humidity.

The reagents and the apparatus shall be maintained at temperature equilibrium in the same room for at least 24 h before being used.

The test room shall be free from fumes or vapours which could contaminate the reagents or apparatus and thus affect the results.

**3.6 Procedure**

**3.6.1 Preparation and calibration of apparatus**

**3.6.1.1** The all-metal Ni-Count-1 apparatus has an internal volume adjusted to 139,5 cm<sup>3</sup>. This internal volume includes all lines of the pressure gauge adjusted so that the gauge indicates 66,7 kPa (500 mmHg) at a room temperature of 27 °C. The tables of surface area versus pressure (furnished with the Ni-Count-1 apparatus) yield accurate specific surface areas if the internal volume of the instrument has been accurately adjusted at the factory to 139,5 cm<sup>3</sup>. To confirm the volume, it is recommended that tests be made on a standard reference black having an agreed nitrogen surface area independently determined by the multipoint method specified in ISO 18852.

**3.6.1.2** The Ni-Count-1 apparatus shall be prepared as specified in the instructions furnished with the apparatus. This includes filling the nitrogen vapour pressure thermometer (3.3.5) with purified nitrogen gas (3.2.1), evacuating the case of the large pressure gauge and closing the case valve, flushing the reservoir and vacuum manifolds several times with nitrogen until air is eliminated and adjusting the voltage to the heaters to maintain a temperature of 300 °C ± 10 °C as measured with a thermometer in the heater well.

If air is admitted to the reservoir at any time, the purging shall be repeated.

**3.6.1.3** The calibration and accuracy of the equipment shall be checked by tests on standard reference blacks.

**3.6.2 Determination**

**3.6.2.1** Using the data in Table 1 as a guide, select the proper sample tube and take the appropriate test-portion mass. If the grade of the carbon black is not known, carry out a preliminary test to determine the mass of the black which gives an adsorption pressure of between 20,0 kPa and 33,3 kPa (150 mmHg and 250 mmHg).

**Table 1 — Recommended sample-tube volumes and test-portion masses for common grades of pressed and pelleted carbon blacks**

Carbon black series	Specific surface area m <sup>2</sup> /g	Sample-tube volume		Mass of test portion g
		Pressed cm <sup>3</sup>	Pelleted cm <sup>3</sup>	
N100	140	5,0	3,5	1,1
N200 — S200	110	7,5	4,5	1,5
N300 — S300	80	10	5,5	2,0
N500	44	18	9	3,6
N600	30	22	11	5,3
N900	20 to 6	15 to 30	10 to 25	10 to 15

**3.6.2.2** Weigh, to the nearest 0,1 mg, a plug of glass wool (3.3.8) of a suitable size to support the filler tube in the sample-tube stem. Record the mass.

**3.6.2.3** Weigh, to the nearest 0,1 mg, a clean, dry sample tube (3.3.6) with its filler tube and glass-wool plug. Record the mass (*m*<sub>1</sub>).

**3.6.2.4** Roughly weigh the predried test portion. (This is the non-degassed mass and is not used in the calculation.)

**3.6.2.5** Place the test portion in the sample tube, introduce the plug of glass wool and push in the filler rod to its proper position.

**3.6.2.6** Sparingly lubricate the ball joint of the sample tube with the high-vacuum grease or lubricant (3.3.7), taking care not to place grease or lubricant inside the stem. Fit the sample-tube ball into the mating metal receptacle on the Ni-Count-1 apparatus and retain the sample tube in place with the metal spring clip.

**3.6.2.7** Start the evacuation of the sample tube through the vacuum manifold and raise the heater around the tube to degas the test portion at  $300\text{ °C} \pm 10\text{ °C}$  for a minimum of 15 min.

**3.6.2.8** During the evacuation, purge the test portion several times with nitrogen gas. To do this, close the valve to the vacuum pump and momentarily open the valve from the nitrogen supply to the vacuum manifold and set the rate by the flow-control valve; then resume evacuation.

**3.6.2.9** Close the vacuum valve and observe the leak detector to determine whether gases are still evolving from the test portion. If the test portion is properly degassed, the leak indicator should not show a change of pressure greater than 0,1 kPa (1 mmHg) over 5 min.

**3.6.2.10** Isolate the degassed test portion from the vacuum manifold by closing the valve. Remove the heater.

**3.6.2.11** If the pressure in the purged nitrogen reservoir is above 65,7 kPa (493 mmHg) at 23 °C [or above 66,7 kPa (500 mmHg) at 27 °C], evacuate to a lower pressure. Complete evacuation is not necessary unless air has been permitted to enter.

Fill the purged reservoir gauge and manifold with nitrogen gas to a pressure of 65,7 kPa (493 mmHg) if the temperature is 23 °C, or to 66,7 kPa (500 mmHg) if the temperature is 27 °C. For each degree respectively above or below the indicated temperatures, add or subtract 0,222 kPa (1,67 mmHg) from the specified pressures.

**3.6.2.12** Open the valve from the nitrogen reservoir to the sample tube by rotating it through three complete turns.

**3.6.2.13** Place the Dewar flask (3.3.4) filled with liquid nitrogen (3.2.2) around the sample tube.

Table 2 — Liquid-nitrogen temperature-correction factor

Nitrogen vapour pressure		Correction factor <i>B</i>	Nitrogen vapour pressure		Correction factor <i>B</i>	Nitrogen vapour pressure		Correction factor <i>B</i>	Nitrogen vapour pressure		Correction factor <i>B</i>
<i>p<sub>N</sub></i>			<i>p<sub>N</sub></i>			<i>p<sub>N</sub></i>			<i>p<sub>N</sub></i>		
mmHg	kPa		mmHg	kPa		mmHg	kPa		mmHg	kPa	
660	88,0	0,954 16	695	92,7	0,974 22	730	97,3	0,994 27	765	102,0	1,014 32
661	88,1	0,954 73	696	92,8	0,974 79	731	97,5	0,994 84	766	102,1	1,014 90
662	88,3	0,955 31	697	92,9	0,975 36	732	97,6	0,995 42	767	102,3	1,015 47
663	88,4	0,955 88	698	93,1	0,975 93	733	97,7	0,995 99	768	102,4	1,016 04
664	88,5	0,956 45	699	93,2	0,976 51	734	97,9	0,996 56	769	102,5	1,016 62
665	88,7	0,957 03	700	93,3	0,977 08	735	98,0	0,997 14	770	102,7	1,017 19
666	88,8	0,957 60	701	93,5	0,977 65	736	98,1	0,997 71	771	102,8	1,017 76
667	88,9	0,958 17	702	93,6	0,978 23	737	98,3	0,998 28	772	102,9	1,018 34
668	89,1	0,958 74	703	93,7	0,978 80	738	98,4	0,998 85	773	103,1	1,018 91
669	89,2	0,959 32	704	93,9	0,979 37	739	98,5	0,999 43	774	103,2	1,019 48
670	89,3	0,959 89	705	94,0	0,979 95	740	98,7	1,000 00	775	103,3	1,020 05
671	89,5	0,960 46	706	94,1	0,980 52	741	98,8	1,000 57	776	103,5	1,020 63
672	89,6	0,961 04	707	94,3	0,981 09	742	98,9	1,001 15	777	103,6	1,021 20
673	89,7	0,961 61	708	94,4	0,981 66	743	99,1	1,001 72	778	103,7	1,021 77
674	89,9	0,962 18	709	94,5	0,982 24	744	99,2	1,002 29	779	103,9	1,022 35
675	90,0	0,962 76	710	94,7	0,982 81	745	99,3	1,002 86	780	104,0	1,022 92
676	90,1	0,963 33	711	94,8	0,983 38	746	99,5	1,003 44	781	104,1	1,023 49
677	90,3	0,963 90	712	94,9	0,983 96	747	99,6	1,004 01	782	104,3	1,024 07
678	90,4	0,964 47	713	95,1	0,984 53	748	99,7	1,004 58	783	104,4	1,024 64
679	90,5	0,965 05	714	95,2	0,985 10	749	99,9	1,005 16	784	104,5	1,025 21
680	90,7	0,965 62	715	95,3	0,985 68	750	100,0	1,005 73	785	104,7	1,025 78
681	90,8	0,966 19	716	95,5	0,986 25	751	100,1	1,006 30	786	104,8	1,026 36
682	90,9	0,966 77	717	95,6	0,986 82	752	100,3	1,006 88	787	104,9	1,026 93
683	91,1	0,967 34	718	95,7	0,987 39	753	100,4	1,007 45	788	105,1	1,027 50
684	91,2	0,967 91	719	95,9	0,987 97	754	100,5	1,008 02	789	105,2	1,028 08
685	91,3	0,968 49	720	96,0	0,988 54	755	100,7	1,008 59	790	105,3	1,028 65
686	91,5	0,969 06	721	96,1	0,989 11	756	100,8	1,009 17	791	105,5	1,029 22
687	91,6	0,969 63	722	96,3	0,989 69	757	100,9	1,009 74	792	105,6	1,029 80
688	91,7	0,970 20	723	96,4	0,990 26	758	101,1	1,010 31	793	105,7	1,030 37
689	91,9	0,970 78	724	96,5	0,990 83	759	101,2	1,010 89	794	105,9	1,030 94
690	92,0	0,971 35	725	96,7	0,991 41	760	101,3	1,011 46	795	106,0	1,031 51
691	92,1	0,971 92	726	96,8	0,991 98	761	101,5	1,012 03	796	106,1	1,032 09
692	92,3	0,972 50	727	96,9	0,992 55	762	101,6	1,012 61	797	106,3	1,032 66
693	92,4	0,973 07	728	97,1	0,993 12	763	101,7	1,013 18	798	106,4	1,033 23
694	92,5	0,973 64	729	97,2	0,993 70	764	101,9	1,013 75	799	106,5	1,033 81

NOTE The liquid-nitrogen temperature-correction factor *B* is derived from the formula  $1 + 0,057\ 3 \times [(p_N - 98,7)/13,3]$ ,

where

*p<sub>N</sub>* is the vapour pressure, in kilopascals, of pure nitrogen at the nitrogen adsorption temperature, measured by means of the nitrogen vapour pressure thermometer (3.3.5);

98,7 is the barometric pressure, in kilopascals, during calibration of the apparatus to determine area *S* at the equilibrium pressure (see Table 3).

If the pressure is expressed in millimetres of mercury, the above formula becomes  $1 + 0,057\ 3 \times [(p_N - 740)/100]$ .

Table 3

Equilibrium pressure		Correlating factor	Surface area	Equilibrium pressure		Correlating factor	Surface area	Equilibrium pressure		Correlating factor	Surface area
mmHg	kPa	<i>F</i>	<i>S</i>	mmHg	kPa	<i>F</i>	<i>S</i>	mmHg	kPa	<i>F</i>	<i>S</i>
100	13,3	0,006 99	255,7	140	18,6	0,010 94	213,8	180	23,9	0,015 98	176,3
101	13,4	0,007 08	254,6	141	18,7	0,011 05	212,8	181	24,1	0,016 12	175,4
102	13,5	0,007 17	253,5	142	18,9	0,011 17	211,8	182	24,2	0,016 26	174,5
103	13,7	0,007 26	252,4	143	19,0	0,011 28	210,8	183	24,3	0,016 41	173,7
104	13,8	0,007 35	251,3	144	19,1	0,011 39	209,8	184	24,5	0,016 56	172,8
105	13,9	0,007 44	250,2	145	19,3	0,011 51	208,8	185	24,6	0,016 70	171,9
106	14,1	0,007 53	249,1	146	19,4	0,011 62	207,9	186	24,7	0,016 85	171,0
107	14,2	0,007 62	248,0	147	19,5	0,011 73	206,9	187	24,9	0,017,00	170,2
108	14,3	0,007 71	247,0	148	19,7	0,011 85	205,9	188	25,0	0,017 15	169,3
109	14,5	0,007 81	245,9	149	19,8	0,011 97	204,9	189	25,1	0,017 31	168,5
110	14,6	0,007 90	244,8	150	19,9	0,012 08	204,0	190	25,3	0,017 46	167,6
111	14,7	0,007 99	243,7	151	20,1	0,012 20	203,0	191	25,4	0,017 61	166,8
112	14,9	0,008 09	241,7	152	20,2	0,012 32	202,0	192	25,5	0,017 77	165,9
113	15,0	0,008 18	241,6	153	20,3	0,012 44	201,1	193	25,7	0,017 93	165,1
114	15,1	0,008 28	240,5	154	20,5	0,012 56	200,1	194	25,8	0,018 08	164,2
115	15,3	0,008 37	239,5	155	20,6	0,012 68	199,2	195	25,9	0,018 24	163,4
116	15,4	0,008 47	238,4	156	20,7	0,012 80	198,2	196	26,1	0,018 40	162,5
117	15,5	0,008 56	237,3	157	20,9	0,012 93	197,3	197	26,2	0,018 56	161,7
118	15,7	0,008 66	236,3	158	21,0	0,013 05	196,3	198	26,3	0,018 73	160,9
119	15,8	0,008 76	235,2	159	21,1	0,013 17	195,4	199	26,5	0,018 89	160,0
120	15,9	0,008 86	234,2	160	21,3	0,013 30	194,5	200	26,6	0,019 05	159,2
121	16,1	0,008 96	233,1	161	21,4	0,013 42	193,5	201	26,7	0,019 22	158,4
122	16,2	0,009 06	232,1	162	21,5	0,013 55	192,6	202	26,9	0,019 39	157,6
123	16,3	0,009 16	231,0	163	21,7	0,013 68	191,7	203	27,0	0,019 56	156,8
124	16,5	0,009 26	230,0	164	21,8	0,013 81	190,7	204	27,1	0,019 73	155,9
125	16,6	0,009 36	229,0	165	21,9	0,013 93	189,8	205	27,3	0,019 90	155,1
126	16,7	0,009 46	227,9	166	22,1	0,014 06	188,9	206	27,4	0,020 07	154,3
127	16,9	0,009 56	226,9	167	22,2	0,014 19	188,0	207	27,5	0,020 24	153,5
128	17,0	0,009 66	225,9	168	22,3	0,014 33	187,1	208	27,7	0,020 42	152,7
129	17,1	0,009 77	224,9	169	22,5	0,014046	186,1	209	27,8	0,020 59	151,9
130	17,3	0,009 87	223,8	170	22,6	0,014 59	185,2	210	27,9	0,020 77	151,1
131	17,4	0,009 97	222,8	171	22,7	0,014 73	184,3	211	28,1	0,020 95	150,3
132	17,5	0,010 08	221,8	172	22,9	0,014 86	183,4	212	28,2	0,021 13	149,5
133	17,7	0,010 19	220,8	173	23,0	0,015 00	182,5	213	28,3	0,021 31	148,7
134	17,8	0,010 29	219,9	174	23,1	0,015 13	181,6	214	28,5	0,021 50	147,9
135	17,9	0,010 40	218,8	175	23,3	0,015 27	180,7	215	28,6	0,021 68	147,2
136	18,1	0,010 51	217,8	176	23,4	0,015 41	179,8	216	28,7	0,021 87	146,4
137	18,2	0,010 61	216,8	177	23,5	0,015 55	178,9	217	28,9	0,022 06	145,6
138	18,3	0,010 72	215,8	178	23,7	0,015 69	178,1	218	29,0	0,022 25	144,8
139	18,5	0,010 83	214,8	179	23,8	0,015 83	177,2	219	29,1	0,022 44	144,0

Table 3 (continued)

Equilibrium pressure		Correlating factor	Surface area	Equilibrium pressure		Correlating factor	Surface area
mmHg	kPa			mmHg	kPa		
220	29,3	0,022 63	143,3	260	34,6	0,031 88	114,7
221	29,4	0,022 82	142,5	261	34,7	0,032 16	114,1
222	29,5	0,023 02	141,7	262	34,9	0,032 44	113,4
223	29,7	0,023 22	141,0	263	35,0	0,032 72	112,8
224	29,8	0,023 42	140,2	264	35,1	0,033 01	112,1
225	29,9	0,023 62	139,5	265	35,3	0,033 30	111,5
226	30,1	0,023 82	138,7	266	35,4	0,033 59	110,8
227	30,2	0,024 02	138,0	267	35,5	0,033 88	110,2
228	30,3	0,024 23	137,2	268	35,7	0,034 18	109,6
229	30,5	0,024 44	136,5	269	35,8	0,034 48	108,9
230	30,6	0,024 65	135,7	270	35,9	0,034 79	108,3
231	30,7	0,024 86	135,0	271	36,1	0,035 09	107,7
232	30,9	0,025 07	134,2	272	36,2	0,035 41	107,1
233	31,0	0,025 29	133,5	273	36,3	0,035 72	106,4
234	31,1	0,025 50	132,8	274	36,5	0,036 04	105,8
235	31,3	0,025 72	132,1	275	36,6	0,036 36	105,2
236	31,4	0,025 94	131,3	276	36,7	0,036 68	104,6
237	31,5	0,026 16	130,6	277	36,9	0,037 01	104,0
238	31,7	0,026 39	129,9	278	37,0	0,037 34	103,4
239	31,8	0,026 61	129,2	279	37,1	0,037 67	102,8
240	31,9	0,026 84	128,4	280	37,3	0,038 01	102,1
241	32,1	0,027 07	127,7	281	37,4	0,038 36	101,5
242	32,2	0,027 31	127,0	282	37,5	0,038 70	100,9
243	32,3	0,027 54	126,3	283	37,7	0,039 05	100,4
244	32,5	0,027 78	125,6	284	37,8	0,039 40	99,8
245	32,6	0,028 02	124,9	285	37,9	0,039 76	99,2
246	32,7	0,028 26	124,2	286	38,1	0,040 12	98,6
247	32,9	0,028 50	123,5	287	38,2	0,040 49	98,0
248	33,0	0,028 74	122,8	288	38,3	0,040 86	97,4
249	33,1	0,028 99	122,1	289	38,5	0,041 23	96,8
250	33,3	0,029 24	121,5	290	38,6	0,041 61	96,3
251	33,4	0,029 50	120,8	291	38,7	0,042 00	95,7
252	33,5	0,029 75	120,1	292	38,9	0,042 38	95,1
253	33,7	0,030 01	119,4	293	39,0	0,042 78	94,6
254	33,8	0,030 27	118,7	294	39,1	0,043 17	94,0
255	33,9	0,030 53	118,1	295	39,3	0,043 57	93,4
256	34,1	0,030 79	117,4	296	39,4	0,043 98	92,9
257	34,2	0,031 06	116,7	297	39,5	0,044 39	92,3
258	34,3	0,031 33	116,1	298	39,7	0,044 81	91,8
259	34,5	0,031 60	115,4	299	39,8	0,045 23	91,2

**3.6.2.14** Permit the adsorption to proceed until the pressure indicated by the large gauge becomes constant.

Observe and record the pressure to the nearest 0,1 kPa (1 mmHg). Ensure the liquid-nitrogen surface is at the proper level round the tube stem. (If a variable stem correction is used in the calculations, measure and record the exposed stem length.)

**3.6.2.15** Lower the Dewar flask from the sample tube and place it around the sensing element of the nitrogen vapour pressure thermometer (3.3.5).

**3.6.2.16** After the gauge pressure of the nitrogen vapour pressure thermometer has become constant, observe the pressure and record its value to the nearest 0,1 kPa (1 mmHg).

**3.6.2.17** Allow the sample tube to warm to above the temperature of water vapour condensation on the tube. The warming process can be hastened by gentle heating.

**3.6.2.18** Add nitrogen gas to the reservoir and sample tube until the pressure gauge reads approximately 1,3 kPa (10 mmHg) above barometric pressure.

Close the valve to the sample tube and remove the tube.

**3.6.2.19** Open the valve to the sample-tube connection to equalize the nitrogen reservoir pressure with the atmospheric pressure. Read the gauge to the nearest 0,1 kPa (1 mmHg) and record the barometric pressure. Close the valve.

**3.6.2.20** As thoroughly as possible, wipe the vacuum grease from the sample tube ball and any moisture from the tube exterior.

Weigh the tube (containing the dry and degassed test portion, glass wool and filler rod) to the nearest 0,1 mg. Record the mass ( $m_2$ ).

**3.6.2.21** Add the value obtained in 3.6.2.16 to the barometric pressure to obtain the vapour pressure  $p_N$  for use in Table 2 to obtain the liquid-nitrogen temperature-correction factor  $B$ .

### 3.7 Expression of results

**3.7.1** Calculate the specific surface area  $S_m$ , in square metres per gram, using the equation:

$$S_m = \frac{S}{m} \left[ 1 - F \left( V_t - V_{dt} - V_{gw} - \frac{m}{\rho} \right) \right] B$$

where

$S$  is the surface area at the equilibrium pressure, obtained from Table 3;

$m$  is the mass, in grams, of the dry and degassed test portion ( $m_2 - m_1$ );

$F$  is the correlating factor, obtained from Table 3;

$V_t$  is the volume, in cubic centimetres, of the sample tube with filler;

$V_{dt}$  is the volume, in cubic centimetres, in the sample-tube stem, with filler inserted, above the surface of the liquid nitrogen;

$V_{gw}$  is the volume, in cubic centimetres, of the glass-wool plug, calculated from its mass and an assumed density of 2,3 g/cm<sup>3</sup>;

$\rho$  is the density, in megagrams per cubic metre, of carbon black, assumed to be equal to 1,8 Mg/m<sup>3</sup>;

$B$  is the liquid-nitrogen temperature-correction factor, obtained from Table 2.

Express the result to the nearest 0,1 m<sup>2</sup>/g.

**3.7.2** Determine the specific surface area of a standard reference black, preferably the current IRB. If the measured surface area of the reference black differs from the agreed value by more than  $\pm 1,2$  m<sup>2</sup>/g, calculate a correction factor for the apparatus as follows:

$$\text{Correction factor} = \frac{\text{Agreed value}}{\text{Measured value}}$$

### 3.8 Test report

The test report shall include the following information:

- a) all details necessary for complete identification of the sample;
- b) a reference to this International Standard (indicating "method A");
- c) the conditions of test;
- d) the mass of the test portion used;
- e) the results obtained from two individual determinations, and their average;
- f) the correction factor and standard reference black used, if applicable.

## 4 Method B, using an Areameter apparatus

### 4.1 Principle

Two laboratory flasks of equal volume, one containing the prepared test portion, the other empty, are filled with nitrogen gas at atmospheric pressure and room temperature. The two flasks are then immersed in liquid nitrogen.

At this temperature, the test portion adsorbs nitrogen, creating a pressure difference between the flask containing the test portion and the reference flask. This pressure difference is measured by means of a differential pressure gauge. The specific surface area of the test portion is calculated from the measured pressure difference, the nitrogen-gas feed pressure and the mass of the test portion.

### 4.2 Reagents

**4.2.1 Nitrogen**, in a cylinder, or another source of prepurified nitrogen of recognized analytical quality.

**4.2.2 Liquid nitrogen.**

**WARNING — Use caution. Gloves and safety glasses should be worn as the temperature of liquid nitrogen is  $-196$  °C.**

### 4.3 Apparatus

**4.3.1 Adsorption apparatus**<sup>1)</sup> (see Figure 4), comprising a reference flask (G) and a sample flask (H) mounted with gas-tight connections.

1) Available for example from Micromeritics Instruments Corporation, 4356 Communications Drive, Norcross, GA 30093-2901, USA ([www.micromeritics.com](http://www.micromeritics.com)). This information is given for the convenience of users of this International Standard and does not constitute an endorsement by ISO of this product.

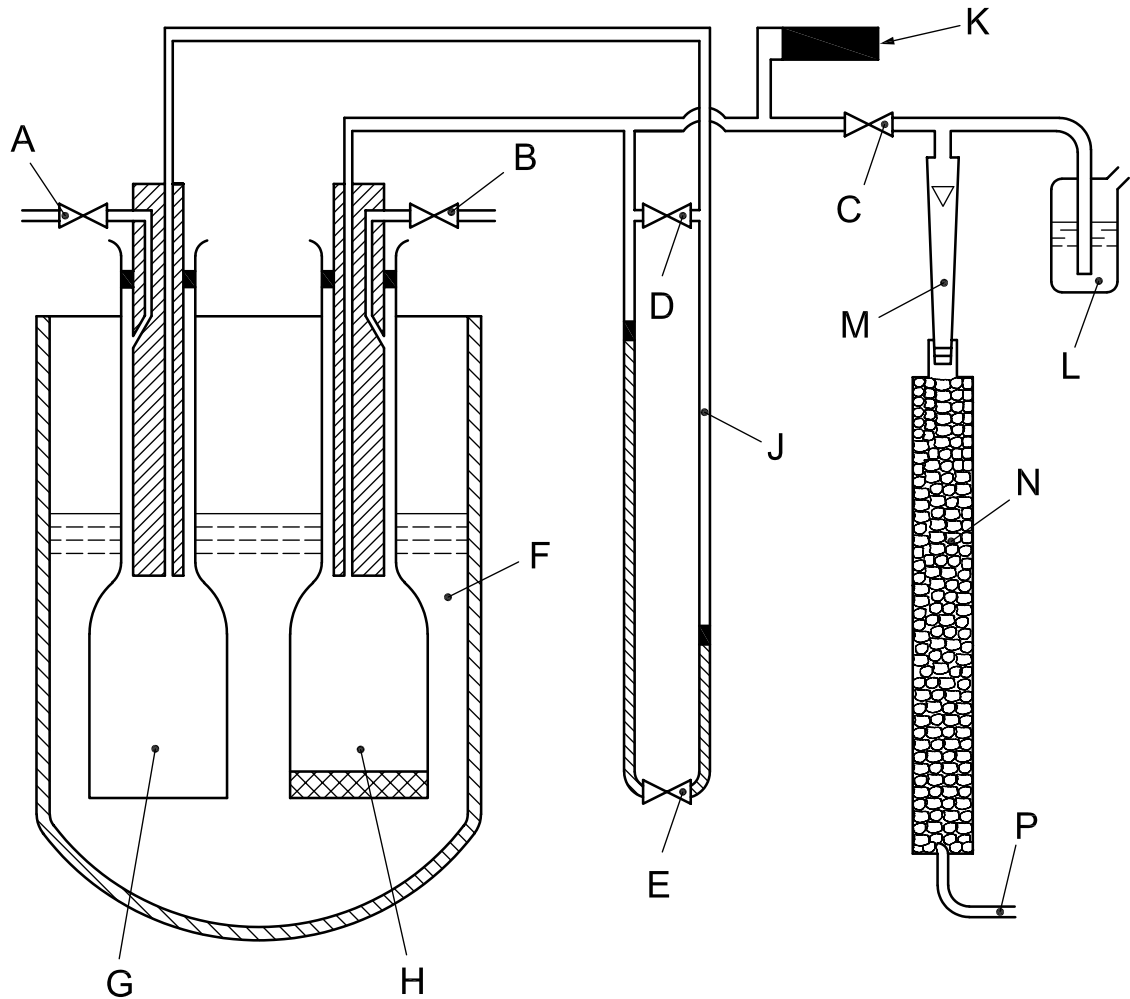

**Key**

A to E	valves	K	compensation volume
F	cold bath	L	safety valve
G	reference flask	M	flow meter
H	sample flask	N	drying tower
J	differential pressure gauge	P	nitrogen inlet

**Figure 4 — Areameter adsorption apparatus**

These connections are provided with one valve each (A and B) by means of which the flasks can be connected with the atmosphere. The gas to be adsorbed is fed into each flask through the connection pieces.

The flasks are made of glass which is resistant to sudden changes of temperature and have a volume of approximately 100 cm<sup>3</sup>. The volume difference between the two flasks shall not exceed 0,1 %.

The flask necks are made of calibrated precision glass tubing with an inside diameter of 5 mm ± 0,02 mm (narrow neck) or 9 mm ± 0,02 mm (wide neck). This ensures that several flasks can be used as sample or reference flasks without having to adjust the compensation volume for each different combination.

A U-tube is mounted between the two flasks, and the arms of the pressure gauge are connected by capillary tubes to the two adsorption flasks. By means of valve D, the two adsorption vessels can be either separated from one another or connected to one another via their capillary tubes. Using valve E, the two liquid arms of the differential pressure gauge can be separated or joined together. The measuring fluid is dibutyl phthalate.

The two arms of the differential pressure gauge are made of calibrated precision glass tubing with an inside diameter of  $5 \text{ mm} \pm 0,02 \text{ mm}$ . Therefore, any change in volume during gas adsorption can be sufficiently accurately calculated. Owing to its short length, the feed capillary to the sample flask is considered as a compensation volume which is adjusted during preparation of the equipment (see Clause A.2).

The gas is introduced into the equipment through valve C. If valves A, B and D are open, the gas flows through both flasks. If valves A and D are closed, the reference flask is shut off and only the sample flask is purged with the gas.

When a measurement is made, only part of the volume enclosed by valves A, B and C is cooled to the measurement temperature by the liquid nitrogen. The remaining volume, which is at or near room temperature, shall not be more than 10 % of the total volume. The connections to the adsorption flasks are therefore capillaries which almost completely fill the necks of the flasks. In this manner, the volume of gas at room temperature is kept to a minimum.

Procedures for commissioning new equipment and for carrying out checks are given in Annex A.

**4.3.2 Control thermostat**, designed to ensure that the adsorption flasks are kept at a constant temperature, and either purged with nitrogen (4.2.1) or evacuated.

**4.3.3 Analytical balance**, accurate to 0,1 mg.

**4.3.4 Drying oven**, capable of being maintained at  $105 \text{ }^\circ\text{C} \pm 2 \text{ }^\circ\text{C}$  or  $125 \text{ }^\circ\text{C} \pm 2 \text{ }^\circ\text{C}$ .

**4.3.5 Heating device**, such as a heating mantle, with a temperature-control device, capable of maintaining a temperature of  $300 \text{ }^\circ\text{C} \pm 10 \text{ }^\circ\text{C}$ , for degassing the test portion.

**4.3.6 Cold bath**, containing liquid nitrogen (4.2.2).

#### 4.4 Preparation of the test portion

The maximum reading (400 mm) of the differential pressure gauge corresponds to a surface area of approximately  $50 \text{ m}^2$ . The mass of the test portion shall therefore be adjusted so that the difference in liquid levels  $\Delta h$  in the differential pressure gauge is as great as possible and at least 50 mm. If the approximate specific surface area is not known, preliminary tests with various test-portion masses shall be performed to establish the most suitable mass for the test portion.

Table 4 gives recommended test-portion masses for various specific surface areas.

Introduce the test portion into the previously dried and weighed sample flask (see 4.3.1), taking care that no material adheres to the walls or the neck. Dry the test portion in accordance with ISO 1126, using the drying oven (4.3.4).

Before the determination, remove as much as possible of the matter already adsorbed on the surface of the test portion by heating the flask to  $300 \text{ }^\circ\text{C} \pm 10 \text{ }^\circ\text{C}$  with the heating device (4.3.5) and purging with nitrogen gas for a minimum of 15 min.

After desorption, cool the test portion to room temperature under a flow of nitrogen, and close and store the flask until required for the determination.

Determine the mass of the test portion after desorption by weighing, to the nearest 0,1 mg, the flask (4.3.1) containing the test portion and subtracting the mass of the empty flask.

Table 4 — Recommended test-portion masses

Carbon black series	Specific surface area m <sup>2</sup> /g	Mass of test portion g
N100	140	0,1 to 0,15
N200 — S200	120	0,15 to 0,2
N300 — S300	80	0,2 to 0,3
N500	40	0,3 to 0,5
N600	30	0,4 to 0,6
N900	20	0,6 to 0,8
	> 200	0,1

#### 4.5 Test conditions

The test should preferably be carried out at ambient conditions of either  $23\text{ °C} \pm 2\text{ °C}$  and  $(50 \pm 5)\%$  relative humidity or  $27\text{ °C} \pm 2\text{ °C}$  and  $(65 \pm 5)\%$  relative humidity.

The reagents and the apparatus shall be maintained at temperature equilibrium in the same room for at least 24 h before being used.

The test room shall be free from fumes or vapours which could contaminate the reagents or apparatus and thus affect the results.

#### 4.6 Procedure

NOTE A to P referred to in the procedure given below are shown in Figure 4.

**4.6.1** Connect flask H containing the prepared test portion to the nitrogen supply and open valves B and C, allowing nitrogen to flow into the flask with valves D, A and E closed.

**4.6.2** Open valves D, A and E and place both reference and sample flask in a water bath maintained at  $23\text{ °C} \pm 2\text{ °C}$ , maintaining the flow of nitrogen.

**4.6.3** After 5 min to 10 min, determine the pressure difference in the flasks by closing valves A, B, C and D. If a pressure difference exists, re-open the valves in the order D, C, B and A, and continue purging with nitrogen. Close valves A, B, C and D when the pressures are equal.

**4.6.4** When pressure equilibrium has been attained, close valve E and stop the nitrogen flow by closing the supply valves.

**4.6.5** Wipe the water drops off the flasks, immerse the flasks in the liquid-nitrogen bath (4.3.6) to the lower mark on the neck and, after 1 min, open valve E very slowly.

**4.6.6** When the resulting pressure difference has stabilized, read the difference in heights of the liquid in the U-tube arms to the nearest 0,5 mm.

**4.6.7** Close valve E. Replace the liquid-nitrogen bath (4.3.6) with a water bath maintained at approximately  $40\text{ °C}$ . After a few minutes, start the nitrogen flow and open valves D, C, B, A and E in that order.

**4.6.8** When the connections have reached room temperature, close valves A, D and E and disconnect the sample flask with valves B and C open.

#### 4.7 Expression of results

4.7.1 Calculate the specific surface area  $S_m$ , in square metres per gram, using the equation:

$$S_m = 1,174 \times 10^{-7} \left[ \frac{(1,05 \times 10^5) - p}{m} \right] \times \left[ (13,71 + 6,656 \times 10^{-5} p) \Delta h + \frac{m}{\rho} \left( \frac{p}{77,6} - \frac{p_B}{295} \right) \right]$$

where

$p$  is the equilibrium pressure, in pascals, given by:

$$p = \frac{109,55 p_B}{393,11 + (0,0098 \Delta h)} - 10,2 \Delta h$$

$m$  is the mass, in grams, of the test portion;

$\Delta h$  is the difference, in millimetres, in the heights of the liquid in the U-tube arms;

$p_B$  is the atmospheric pressure, in pascals;

$\rho$  is the density, in megagrams per cubic metre, of the test sample, assumed to be equal to 1,8 Mg/m<sup>3</sup>.

NOTE For specific surface areas greater than 1 m<sup>2</sup>/g, the term

$$\frac{m}{\rho} \left( \frac{p}{77,6} - \frac{p_B}{295} \right)$$

may be ignored.

Express the result to the nearest 0,1 m<sup>2</sup>/g.

4.7.2 Calculation may be simplified by the use of a nomogram (see Figure 5).

Place a straightedge over the nomogram to join the measured value of  $\Delta h$  on the  $\Delta h$  scale with the measured value of  $p_B$  on the vertical  $p_B$  scale. Record the value at the point of intersection of the line and scale A.

Place a straightedge over the nomogram to join the measured value of  $\Delta h$  on the  $\Delta h$  scale with the measured value of  $p_B$  on the inclined, reduced  $p_B$  scale. Record the value at the point of intersection of the line and scale B.

The specific surface area, in square metres per gram, is given by the equation:

$$S_m = \frac{A \Delta h}{m} + \frac{B}{\rho p}$$

where

$A$  and  $B$  are the scale A and scale B values derived from the nomogram as described above;

$\Delta h$ ,  $m$ ,  $\rho$  and  $p$  are as defined in 4.7.1.

Express the result to the nearest 0,1 m<sup>2</sup>/g.

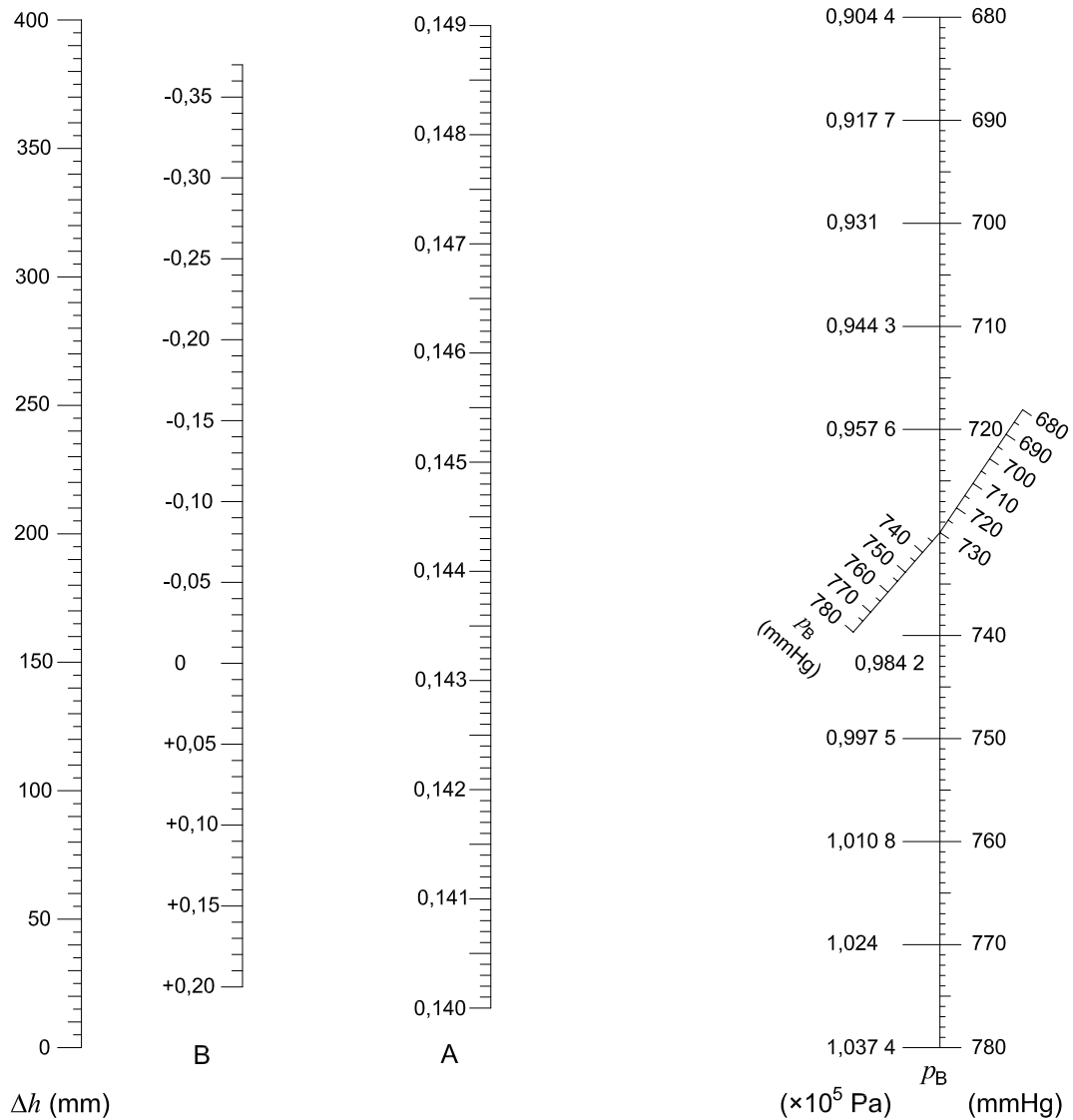

**Key**

- A scale A
- B scale B

**Figure 5 — Nomogram**

**4.7.3** Determine the specific surface area of a standard reference black, preferably the current IRB, and, if the measured surface area of the reference black differs from the agreed value by more than  $\pm 1,2 \text{ m}^2/\text{g}$ , calculate a correction factor for the apparatus as follows:

$$\text{Correction factor} = \frac{\text{Agreed value}}{\text{Measured value}}$$

**4.8 Test report**

The test report shall include the following information:

- a) all details necessary for complete identification of the sample;
- b) a reference to this International Standard (indicating “method B”);
- c) the conditions of test;

- d) the mass of the test portion used;
- e) the results obtained from two individual determinations, and their average;
- f) the correction factor and standard reference black used, if applicable;
- g) the drying temperature used.

## 5 Method C, using gas chromatography

### 5.1 Principle

Nitrogen is adsorbed on the surface of a test portion of carbon black at the temperature of liquid nitrogen. The nitrogen is then desorbed by warming the test portion in a water bath. The desorbed nitrogen is detected with the thermal-conductivity detector of a gas chromatograph, and the quantity desorbed is measured in terms of a peak produced by a potentiometric recorder. The size of this peak is then compared with the size of the peak produced under the same conditions by a reference black, of the same type, of known specific surface area.

This method might not be suitable for thermal blacks (N800 and N900 series).

### 5.2 Reagents

**5.2.1 Helium/nitrogen mixture**, comprising 10 % to 20 % nitrogen (15 % is often used) mixed with helium in a size 1A cylinder. It is essential, however, that the same mixture be used for both calibration and testing. The mixture shall be completely dry.

NOTE Gas mixtures of known composition can be obtained commercially.

**5.2.2 Standard reference black.**

### 5.3 Apparatus

**5.3.1 Gas chromatograph**, with a thermostatically controlled thermal-conductivity detector.

**5.3.2 Potentiometric recorder**, sensitivity 1 mV.

**5.3.3 Sample tubes**, U-tube type, of a size to fit the chromatograph used.

**5.3.4 Two Dewar flasks**, one for liquid nitrogen, the other for water at 25 °C.

**WARNING — Use caution. Gloves and safety glasses should be worn as the temperature of liquid nitrogen is –196 °C.**

**5.3.5 Oven**, capable of being maintained at 125 °C ± 5 °C, for drying the test portion.

**5.3.6 Heating device**, such as a heating mantle, with a temperature-control device, capable of maintaining a temperature of 300 °C ± 10 °C, for degassing the test portion.

**5.3.7 Analytical balance**, accurate to 0,1 mg.

**5.3.8 Desiccator.**

## 5.4 Test conditions

The test should preferably be carried out in ambient conditions of either  $23\text{ °C} \pm 2\text{ °C}$  and  $(50 \pm 5)\%$  relative humidity or  $27\text{ °C} \pm 2\text{ °C}$  and  $(65 \pm 5)\%$  relative humidity.

The reagents and the apparatus shall be maintained at temperature equilibrium in the same room for at least 24 h before being used.

The test room shall be free from fumes or vapours which could contaminate the reagents or apparatus and thus affect the results.

## 5.5 Procedure

**5.5.1** Take a clean sample tube (5.3.3), rinse with distilled water and dry at  $125\text{ °C} \pm 5\text{ °C}$ . Allow to cool to room temperature in the desiccator (5.3.8);

**5.5.2** Weigh, to the nearest 0,1 mg, the dried sample tube on the analytical balance (5.3.7). Record the mass ( $m_1$ ). Roughly weigh out a test portion (take between 0,15 g and 0,75 g, depending on the carbon black series) (see Table 5) and place it in the dried sample tube.

**Table 5 — Recommended test-portion masses**

Carbon black series	Mass of test portion
	g
N100	0,15
N200	0,18
N300	0,25
N500	0,45
N600	0,60
N700	0,75

**5.5.3** Heat the sample tube and contents in the oven (5.3.5) at  $125\text{ °C} \pm 5\text{ °C}$  for 1 h. Allow to cool to room temperature in the desiccator.

**5.5.4** Weigh, to the nearest 0,1 mg, the sample tube containing the dried test portion. Record the mass ( $m_2$ ).

**5.5.5** Place small plugs of glass wool (2 mm × 2 mm in area) in each arm of the tube.

These plugs shall be thin enough to allow nitrogen to flow unimpeded through the tube, but thick enough to prevent any carbon black fines from being blown out of the tube.

**5.5.6** Connect the sample tube containing the test portion to the detector of the gas chromatograph and begin purging the entire system with helium/nitrogen mixture (5.2.1) at approximately  $0,8\text{ cm}^3/\text{s}$  or at another convenient rate. Heat the sample tube to  $300\text{ °C}$  with the heating device (5.3.6) for a minimum of 15 min to remove adsorbed contaminants.

NOTE For blacks with a specific surface area in the order of  $150\text{ m}^2/\text{g}$ , a flow rate of  $1,5\text{ cm}^3/\text{s}$  gives better precision, while for blacks with a specific surface area less than  $45\text{ m}^2/\text{g}$ ,  $0,5\text{ cm}^3/\text{s}$  is more suitable.

Use the same rate for reference black and test portion.

Continue running until the pen trace on the potentiometric-recorder strip chart is a straight line (fully purged).

**5.5.7** Place a Dewar flask (5.3.4) containing liquid nitrogen around the sample tube to where the level of the liquid nitrogen is within 13 mm of the rubber connector used to join the sample tube to the chromatograph system. This gives a negative peak on the strip chart, but the trace should return to the original baseline within 2 min to 5 min, indicating that adsorption of nitrogen on the test portion is complete.

During the adsorption period, adjust the attenuator setting to the required range. For an F&M chromatograph, use  $\times 32$  for 0,1 g of N770 to N440 and  $\times 64$  for N330 to N220. For the Perkin-Elmer model 212B, use position 1 for all surface areas below 300 m<sup>2</sup>/g and position 2 for surface areas above 300 m<sup>2</sup>/g. With other models of gas chromatograph, previous experience is necessary to determine the required setting.

NOTE Adsorption may require up to 30 min at the 0,5 cm<sup>3</sup>/s flow rate.

**5.5.8** With the recorder chart drive in the forward position, rapidly remove the Dewar flask containing liquid nitrogen and immerse the sample tube to the same level in the ambient-temperature (25 °C) water in the other Dewar flask.

This causes the nitrogen to be desorbed rapidly from the carbon black to give a symmetrical desorption peak in the positive direction on the strip chart recorder. In the event of "tailing" which is sometimes experienced with high-surface-area blacks, use a higher helium/nitrogen flow rate. Desorption peaks should have half-widths of approximately 30 mm to 50 mm. If the peak half-width is smaller, reduce the flow rate.

**5.5.9** Repeat 5.5.1 to 5.5.8 for any other samples to be tested, and for a reference black of a type similar to that or those being tested. Use the same carrier-gas flow rate with all test portions (samples and reference) of the sample type.

**5.5.10** During the procedure, work using standard gas-chromatographic techniques.

## 5.6 Expression of results

**5.6.1** Measure the area under the desorption peaks by the length  $\times$  half-width method or, if an integrator is used, by totalling the number of counts produced by the integrator.

**5.6.2** Divide the total counts or area units by the mass, in grams, of the dried, degassed test portion ( $m_2 - m_1$ ) to obtain the peak area per gram.

**5.6.3** Calculate the specific surface area of each unknown sample  $S_{mU}$ , in square metres per gram, using the equation:

$$S_{mU} = \frac{S_{m\text{ref}} \times P_{\text{unknown}}}{P_{\text{ref}}}$$

where

$S_{m\text{Ref}}$  is the specific surface area, in square metres per gram, of the reference black used;

$P_{\text{unknown}}$  is the peak area per gram for the unknown sample;

$P_{\text{ref}}$  is the peak area per gram for the reference black used.

Express the result to the nearest 0,1 m<sup>2</sup>/g.

## 5.7 Test report

The test report shall include the following information:

- all details necessary for complete identification of the sample;
- a reference to this International Standard (indicating "method C");
- the conditions of test;



- d) the mass of the test portion used;
- e) the results obtained from two individual determinations, and their average.

## 6 Method D, using a Monosorb surface-area analyser

### 6.1 Principle

Nitrogen is adsorbed on to the surface of a test portion of carbon black at the temperature of liquid nitrogen. The sample is then warmed, causing desorption. The nitrogen desorbed is detected with the thermal-conductivity cell of a Monosorb analyser, which gives a digital read-out of total surface area relative to the mass of the test portion.

This method might not be suitable for thermal blacks (N800 and N900 series).

### 6.2 Reagents

**6.2.1 Liquid nitrogen**, 99,997 % pure and with a moisture content below 5 ppm.

**WARNING — Use caution. Gloves and safety glasses should be worn as the temperature of liquid nitrogen is  $-196\text{ }^{\circ}\text{C}$ .**

**6.2.2 Helium/nitrogen mixture**, comprising 10 % to 20 % nitrogen (15 % is often used) mixed with helium in a size 1A cylinder. It is essential, however, that the same mixture be used for both calibration and testing. The mixture shall be completely dry.

NOTE Gas mixtures of known composition can be obtained commercially.

### 6.3 Apparatus

**6.3.1 Monosorb surface-area analyser<sup>2)</sup>**, equipped with the following:

**6.3.1.1 Heating mantle.**

**6.3.1.2 Two Dewar flasks.**

**6.3.1.3 Five sample cells.**

**6.3.1.4 Sample-cell holders.**

**6.3.1.5 Two cold-trap U-tubes.**

**6.3.1.6 Zeroing syringe**, capacity  $1\text{ cm}^3$ .

**6.3.1.7 Copper input line.**

**6.3.1.8 Septa.**

**6.3.2 Analytical balance**, accurate to 0,1 mg.

**6.3.3 Apparatus for supplying dry air** of non-detectable humidity.

---

2) Available from Quantachrome Corp., 5 Aerial Way, P.O. Box 9011, Syosset, NY 11791-9011, USA. This information is given for the convenience of users of this International Standard and does not constitute an endorsement by ISO of this product.

**6.3.4 Small funnel**, with a stem approximately the same diameter as the sample cell, or a **V-shaped spatula**.

**6.3.5 Beaker**, capacity 500 cm<sup>3</sup>.

**6.3.6 Drying oven**, capable of being maintained at 105 °C ± 2 °C or 125 °C ± 2 °C.

**6.3.7 Pipe-cleaner brush**.

**6.3.8 Soap-bubble flow meter**, suitable for measuring a gas flow rate of 15 cm<sup>3</sup>/min.

## 6.4 Initial installation

Follow the instruction manual supplied with the instrument.

## 6.5 Test conditions

The test should preferably be carried out in ambient conditions of either 23 °C ± 2 °C and (50 ± 5) % relative humidity or 27 °C ± 2 °C and (65 ± 5) % relative humidity.

The reagents and the apparatus shall be maintained at temperature equilibrium in the same room for at least 24 h before being used.

The test room shall be free from fumes or vapours which could contaminate the reagents and apparatus and thus affect the results.

## 6.6 Calibration

Check the instrument by using standard reference blacks.

## 6.7 Procedure

**6.7.1** Fill the Dewar flask (6.3.1.2) with liquid nitrogen (6.2.1) and immerse a cold-trap U-tube (6.3.1.5) in the flask.

Keep the liquid-nitrogen level within 12 mm to 25 mm of the sample-cell holder (6.3.1.4) during all tests. Cover the flask to prevent excessive loss of liquid nitrogen (e.g. using sheet Styrofoam).

**6.7.2** Place an empty sample cell (6.3.1.3) in a cell holder and insert it into the sample station with one hand while holding on to the back of the Monosorb unit with the other.

The sample station shall have a sample cell in place to allow flow through the system, and the electronics shall not be left on for very long periods with this sample cell removed.

**6.7.3** Open the toggle valve and allow the gas mixture (6.2.2) to flow at 15 cm<sup>3</sup>/min to purge the instrument for a minimum of 5 min. Do this before turning on the electronics, to prevent damage to the sensing elements.

**6.7.4** Plug the heating-mantle power line and the thermocouple lead into their respective receptacles. Set the heat-control knob to 50 on the scale. (Additional adjustment to set the heating-mantle temperature to 300 °C ± 10 °C may be made while the electronics are warming up.)

**6.7.5** After purging the instrument for 5 min, turn on the power switch and allow the electronics to warm up for a minimum of 30 min.

**NOTE** If the instrument is used on a regular basis, it is recommended that it be left on continuously, but with the gas flow reduced to the 1 cm mark on the flow meter (6.3.8).

**6.7.6** Check that the flow-meter float is centred on the 6 cm mark. Adjust the flow-control valve if necessary.

**6.7.7** With the attenuator in the “1” position and the polarity switch towards the front of the instrument, zero the meter and clear the counter.

NOTE Newer models of the Monosorb analyser do not have an attenuator.

**6.7.8** Pump the zeroing syringe (6.3.1.6) two or three times and then inject 1,0 cm<sup>3</sup> of dry air through the septum (6.3.1.8) on the front panel. The counter should be operating in about 2 min.

Renew the septum after 200 injections or if a leak is suspected.

**6.7.9** Check that the meter goes from zero to a peak of 95 % to 100 % of the full scale and then back to zero for a complete count of  $2,84 \pm 0,03$ . If the count is outside this specified range, adjust the counter and repeat the zeroing procedure, starting from the beginning of 6.7.8.

**6.7.9.1** Use the sensitivity-control knob to adjust the 95 % to 100 % rigid peak.

**6.7.9.2** Use the counter-control knob to adjust the count. Very small adjustments of the counter may be made by means of the flow-control valve. If the count is greater than 2,84, increase the flow slightly; if less, decrease the flow.

**6.7.9.3** The counter should cease to count when the meter is on zero. If not, adjust the threshold control (see instruction manual).

**6.7.10** The instrument shall be considered zeroed when two corrective counts are within 0,02 of each other.

**6.7.11** Weigh, to the nearest 0,1 mg, a clean, dry sample cell. Record the mass ( $m_1$ ).

**6.7.12** Weigh out dry test portions of carbon black to the nearest 0,1 mg in accordance with Table 6.

**Table 6 — Mass of test portion**

Carbon black series	Mass of test portion g
N100	$0,15 \pm 0,02$
N200	$0,18 \pm 0,02$
N300	$0,25 \pm 0,03$
N500	$0,45 \pm 0,05$
N600	$0,60 \pm 0,06$
N700	$0,75 \pm 0,08$

**6.7.13** Using the small funnel (6.3.4), pour the test portion into the sample cell. Use the pipe-cleaner brush (6.3.7) to remove any dirt that remains on the side walls of the cell.

NOTE A V-shaped spatula works well for pouring the test portion into the cell if a small funnel is not available.

**6.7.14** Insert the sample cell into a cell holder and insert the cell holder into the “outgas” station.

**6.7.15** Place the heating mantle around the sample cell and apply the heating-mantle clamp.

The mantle temperature will at first drop below 300 °C, but will then normally rise in a few minutes to  $300 \text{ °C} \pm 10 \text{ °C}$ .

**6.7.16** Outgas test portions of N100, N200, N300, N500, N600 and N700 series blacks for a minimum of 10 min and preferably for 30 min.

Some small-particle, high-surface-area blacks in the N100 and N200 series might require extended outgassing for up to 45 min longer. This may be determined by alternate outgassing and testing of the same test portion until repeatable results are obtained.

**6.7.17** Remove the outgassed test portion from the “outgas” station.

**6.7.18** Remove the cell and cell holder from the sample station.

**6.7.19** Insert the outgassed test portion into the sample station.

Within a few seconds, the counter will start and a peak reading will occur on the meter. This peak is due to the small amount of air that is trapped on the vent side of the test portion as the holder is inserted. Step 6.7.21 shall not be started until this signal is complete.

**6.7.20** If another test portion is to be tested, insert it into the “outgas” station and place the heating mantle in position to begin outgassing.

**6.7.21** Set the attenuator (see, however, the note to 6.7.7). The attenuator setting for the masses given in Table 6 are usually as follows:

- carbon black series N100, N200, N300: setting 8;
- carbon black series N500, N600, N700: setting 4.

**6.7.22** Push the polarity switch towards the rear of the instrument.

**6.7.23** Adjust the signal meter to zero using the coarse/fine zero-adjustment knobs.

**6.7.24** Raise the Dewar flask until the liquid nitrogen is 12 mm to 25 mm from the sample-cell holder.

**6.7.25** After approximately 1 min, the meter will show a signal and the counter will start.

NOTE This is the adsorption signal that is not used for surface-area measurement but can be used for checking the current-attenuator setting. The correct attenuator setting is the highest setting that causes the signal peak to occur below 50 % of the meter scale.

**6.7.26** When the meter returns to zero and no counts, pull the polarity switch towards the front of the instrument.

**6.2.27** Re-zero the signal meter and clear the counter by pressing the counter button.

**6.7.28** Remove the Dewar flask and immediately immerse the sample cell in the beaker (6.3.5), filled with water at room temperature, until the flow-meter ball returns to the 6 cm mark.

It is important that the flow-meter ball returns to the 6 cm mark before the counter starts. The immediate immersion in water accomplishes this.

**6.7.29** In approximately 1 min, the meter will begin to show a signal and the counter will start.

**6.7.30** Remove the beaker of water and wipe off the excess water with a damp sponge.

NOTE The use of a damp sponge avoids static build-up.

**6.7.31** Observe the peak of this desorption signal. It shall occur in the 50 % to 100 % range of the meter for an acceptable test.

If the peak occurs outside this range, begin the test again at 6.7.22, using the next higher or lower attenuator setting, whichever is appropriate.

**6.7.32** After the meter returns to zero, record the counter reading and the attenuator setting.

To repeat the test on the same test portion, repeat 6.7.22 to 6.7.32.

**6.7.33** Remove the sample cell and holder from the sample station.

**6.7.34** If another test portion has been outgassed while testing this test portion, then proceed as from 6.7.17 with another test.

**6.7.35** Remove the sample cell from the cell holder and weigh, to the nearest 0,1 mg, the test portion and sample cell. Record the mass ( $m_2$ ).

Do not remove the sample cell from the cell holder until ready to weigh. The quick-disconnect assembly of the cell holder is airtight and prevents water and other contaminants from being absorbed by the test portion.

## 6.8 Expression of results

**6.8.1** Calculate the specific surface area  $S_m$ , expressed in square metres per gram, using the equation:

$$S_m = \frac{A \times C}{m_2 - m_1}$$

where

$A$  is the attenuator setting;

$C$  is the counter reading, in square metres;

$m_1$  is the mass, in grams, of the sample cell;

$m_2$  is the mass, in grams, of the test portion and sample cell.

Express the result to the nearest 0,1 m<sup>2</sup>/g.

**6.8.2** Determine the specific surface area of a standard reference black, preferably the current IRB. If the measured surface area of the reference black differs from the agreed value by more than  $\pm 1,2$  m<sup>2</sup>/g, calculate a correction factor for the apparatus as follows:

$$\text{Correction factor} = \frac{\text{Agreed value}}{\text{Measured value}}$$

## 6.9 Test report

The test report shall include the following information:

- a) all details necessary for complete identification of the sample;
- b) a reference to this International Standard (indicating "method D");
- c) the conditions of test;
- d) the mass of the test portion used;

- e) the results obtained from two individual determinations, and their average;
- f) the correction factor and standard reference black used, if applicable;
- g) the drying temperature used.

## Annex A (normative)

### Preparation of Areameter

#### A.1 General

When commissioning new equipment or when checking existing equipment, carry out the following tests to check whether the compensation volume (K in Figure 4) is correctly adjusted and that the apparatus is leakproof.

#### A.2 Volume-equalization test

It is essential for this test that valve D is gastight (see Clause A.3).

Connect the empty adsorption flasks to the apparatus, aligning the upper marks on the flask necks with the lower gasket. Then open all the valves and purge the apparatus with nitrogen. Use a flow rate of  $2,8 \text{ cm}^3/\text{s} \pm 0,15 \text{ cm}^3/\text{s}$ .

While purging, keep the flasks immersed in a water bath at  $23 \text{ }^\circ\text{C} \pm 2 \text{ }^\circ\text{C}$  to the lower mark on the flask necks, so that both flasks attain the same temperature. When this can be assumed to have taken place (allow at least 5 min), seal the apparatus from the atmosphere and separate the flasks from each other by closing valves A, B, C and D in that order. Closing valve D might cause a minor pressure difference. If this pressure difference changes within the next 2 min, complete temperature equilibrium has not been reached between the adsorption flasks. In this case, re-open valves D, C, B and A in that order and again purge the apparatus with nitrogen. Repeat the test after a few minutes. When temperature equilibrium has been reached, close valve E. Remove the water bath, wipe off the adhering water drops and immerse the flasks to the lower mark on the flask necks in a cold bath of liquid nitrogen.

As soon as the flasks have assumed the temperature of the liquid nitrogen (for empty flasks, after approximately 1 min), open valve E very slowly. If the volumes of the sample flask and the reference flask are correctly balanced, there will be no pressure difference between them. In this case, close valve E again and re-open valve D. Then remove the cold bath and replace by a water bath at approximately  $40 \text{ }^\circ\text{C}$  to thaw out the flasks. Remove the warm-water bath as soon as the flasks have reached approximately room temperature. After a few minutes, re-open valves C, B and A in that order, and purge the apparatus with nitrogen.

Cooling and heating of the flasks might result in high pressure differences for short periods. This could cause the dibutyl phthalate in the U-tube to enter other parts of the apparatus. It is therefore important that valve E be kept open at the times indicated.

If a pressure difference should arise during the preparation of the apparatus, change the compensation volume (K in Figure 4) at room temperature in such a way that the volumes on both sides of the differential pressure gauge are equal. Check the volume balance by repeating the above test.

#### A.3 Leak test

If balancing the volumes at the temperature of liquid nitrogen results in a continuously increasing, or very considerable, pressure difference (greater than 400 mm) after valve E has slowly been opened, this is evidence of leaks from the apparatus to the atmosphere (i.e. through valves A, B and C).

The gas tightness of valve D cannot be checked by means of the pressure difference, and this valve shall therefore be tested separately. To do this, immerse the flasks in the cold bath, close valves B, C and D and open valves A and E. By means of valve A, produce a difference in liquid heights of approximately 300 mm and close valve A.

This difference in height shall not change by more than 1 mm within 10 min.

#### **A.4 Operational check**

The correct operation of the apparatus shall be checked initially, and periodically during use, by measurement of the surface area of a carbon black of known specific surface area.

#### **A.5 Maintenance**

Replace the dibutyl phthalate in the U-tube if it becomes polluted, or at least once a year. Also replace exhausted silica gel in the drying tower.





