

INTERNATIONAL STANDARD

ISO
4643

Second edition
1992-02-01

Moulded plastics footwear — Lined or unlined poly(vinyl chloride) boots for general industrial use — Specification

*Articles chaussants moulés en plastique — Bottes industrielles doublées
ou non doublées en poly(chlorure de vinyle) d'usage général —
Spécifications*



Reference number
ISO 4643:1992(E)

Foreword

ISO (the International Organization for Standardization) is a worldwide federation of national standards bodies (ISO member bodies). The work of preparing International Standards is normally carried out through ISO technical committees. Each member body interested in a subject for which a technical committee has been established has the right to be represented on that committee. International organizations, governmental and non-governmental, in liaison with ISO, also take part in the work. ISO collaborates closely with the International Electrotechnical Commission (IEC) on all matters of electrotechnical standardization.

Draft International Standards adopted by the technical committees are circulated to the member bodies for voting. Publication as an International Standard requires approval by at least 75 % of the member bodies casting a vote.

International Standard ISO 4643 was prepared by Technical Committee ISO/TC 45, *Rubber and rubber products*.

This second edition cancels and replaces the first edition (ISO 4643:1980), from which it differs in the following respects:

- a) there is a minimum requirement for the intercleat thickness;
- b) the methods of measuring the thickness of the boot parts are specified in more detail;
- c) the requirements for the preparation of test pieces are more clearly specified;
- d) the hardness test is required to be carried out not less than 7 days after manufacture, but the upper limit of 90 days has been deleted;
- e) the thickness of the foxing at the back of the heel is 4,0 mm compared with 3,5 mm;
- f) the requirements for the breaking force of the coated fabric upper material are deleted, because wear performance is more accurately predicted by the boot upper flexing test;

© ISO 1992

All rights reserved. No part of this publication may be reproduced or utilized in any form or by any means, electronic or mechanical, including photocopying and microfilm, without permission in writing from the publisher.

International Organization for Standardization
Case Postale 56 • CH-1211 Genève 20 • Switzerland

Printed in Switzerland

- g) tensile properties are measured at 23 °C and the maximum value for the modulus at 100 % elongation has been increased to 4,6 MPa for the upper and 5,0 MPa for the soling to allow for both single and double injection processes; the minimum values for the modulus at 100 % elongation are unchanged;
- h) the minimum value for the elongation at break of the upper material has been reduced to 250 %, to take into account the effect of increased polymer orientation in a moulder upper compared to that in a sole;
- i) the hardness range of the polyvinyl chloride compound has been changed for both the upper and soling compound, to allow for both single and double injection processes;
- j) there is the addition of reference to the dimensions of three-quarter and full thigh boots;
- k) a minimum radius has been specified for the corners at the base of the sole pattern;
- l) marking of footwear now includes the identity of the country of origin, distributor or retailer;
- m) the maximum cold flex temperature has been reduced from – 25 °C to – 35 °C;
- n) the volatility limit has been raised from 1,6 % to 2,0 %.

Annexes A, B and C form an integral part of this International Standard. Annex D is for information only.

Moulded plastics footwear — Lined or unlined poly(vinyl chloride) boots for general industrial use — Specification

1 Scope

This International Standard specifies requirements for boots, moulded from poly(vinyl chloride) compounds, for general industrial use. The boots may be either fabric-lined or unlined and of any style from ankle boots to full thigh height inclusive.

2 Normative references

The following standards contain provisions which, through reference in this text, constitute provisions of this International Standard. At the time of publication, the editions indicated were valid. All standards are subject to revision, and parties to agreements based on this International Standard are encouraged to investigate the possibility of applying the most recent editions of the standards indicated below. Members of IEC and ISO maintain registers of currently valid International Standards.

ISO 37:1977, *Rubber, vulcanized — Determination of tensile stress-strain properties.*

ISO 48:1979, *Vulcanized rubbers — Determination of hardness (Hardness between 30 and 85 IRHD).*

ISO 176:1976, *Plastics — Determination of loss of plasticizers — Activated carbon method.*

ISO 458-1:1985, *Plastics — Determination of stiffness in torsion of flexible materials — Part 1: General method.*

ISO/R 463:1965, *Dial gauges reading in 0.01 mm, 0.001 in and 0.000 1 in.*

ISO 10335:1990, *Rubber and plastics footwear — Nomenclature.*

3 Definitions

For the purposes of this International Standard, the definitions given in ISO 10335 apply.

4 Design requirements

NOTE 1 Suggested ranges for heights of boots are given in annex D.

4.1 Soling pattern

The soling shall have radiused corners at the base of the sole pattern and the radius for such corners shall be not less than 1,5 mm.

NOTE 2 The pattern of the soling can have a significant effect on the formation of premature cracks.

4.2 Minimum thicknesses

The minimum thicknesses of the boot shall be in accordance with table 1 for each individual value obtained when measured as described in annex A.

4.3 Materials and components

The upper, soling and heel shall be moulded from homogeneously mixed poly(vinyl chloride) compounds in which poly(vinyl chloride) shall be the dominant single polymer in the compound.

Table 1 — Minimum thickness

Dimensions in millimetres

Boot component	Minimum thickness			
Boot upper	1,5 of which not less than 1,0 shall be of poly(vinyl chloride) compound			
Foxing				
a) at the heel	4,0			
b) elsewhere	3,0			
	Over cleats		Between cleats	
	Men's	Women's	Men's	Women's
Boot bottom				
a) full thickness	12,0	10,0	7,0	5,0
b) outsole only	8,0	6,0	3,0	2,5
Heel				
a) full thickness	25,0	20,0	19,0	14,0
b) wearing surface to filler block	9,0	4,0	3,0	2,5

5 Physical properties

5.1 General

Materials from the upper and material from the sole shall be tested as two separate compounds, even if the boot is known to have been made by a single injection process. Test pieces from the material of the boot shall be prepared by any of the permitted procedures given in ISO 37.

5.2 Resistance to flexing of boot upper

When tested in accordance with the method described in annex B with one test piece in each direction of flexing, no cracking of the types specified in annex B shall occur in either during 150 000 flex cycles.

5.3 Tensile properties

The modulus at 100 % elongation, and the elongation at break of the upper and the soling shall be determined in accordance with the method described in ISO 37 at $23 \text{ }^\circ\text{C} \pm 2 \text{ }^\circ\text{C}$, using where practicable type 1 dumb-bell test pieces taken from the product.

The direction of test shall be along the sole and up the leg. If it is necessary, because of the shortage of material, to use the smaller, type 2, dumb-bell test piece, the size of the dumb-bell used shall be stated when expressing results.

Where practicable, test pieces shall be $2,0 \text{ mm} \pm 0,2 \text{ mm}$ thick; if necessary, in order to ensure that no fabric is included in the test pieces, thinner test pieces shall be used, and the thickness used shall be stated when expressing results. In the

case of a lined boot, the lining shall be removed by careful use of either a minimum amount of a suitable solvent, such as methyl ethyl ketone, or a leather-splitting machine. The test pieces after either of these treatments shall be conditioned for 24 h at $23 \text{ }^\circ\text{C} \pm 2 \text{ }^\circ\text{C}$ and tested at this temperature.

Five test pieces shall be used for each test and the middle value of each group of five test results shall be in accordance with the values given in table 2. Otherwise a) and b) shall be applied as follows:

- In the elongation at break test, if the middle value is below and the highest value is above the appropriate value given in table 2, five further test pieces shall be tested. The material shall be deemed to comply with the requirements of this International Standard only if the average of the middle two values of all ten results is now above the appropriate value.
- In the test for modulus at 100 % elongation, if the middle value is outside the appropriate range given in table 2, but some results are inside, five further test pieces shall be tested. The material shall be deemed to comply with the requirements of this International Standard only if the average of the middle two values of all ten results is within the appropriate range.

Table 2 — Limits for tensile properties

Boot component	Modulus at 100 % elongation	Minimum elongation at break
	MPa	%
Upper	1,3 to 4,6	250
Soling	2,1 to 5,0	300

5.4 Hardness

The hardness of the materials, measured not less than 96 h after moulding and determined in accordance with the appropriate method of ISO 48 at $23\text{ °C} \pm 2\text{ °C}$ after conditioning at that temperature for not less than 3 h, shall be as given in table 3.

For the soling compound, all measurements shall be taken on the prepared surface of a test piece which was adjacent to the wearing surface of the sole and which does not include any filler or upper compound. For the upper compound, all measurements shall be taken on the actual outer surface of the boot leg.

The minimum thickness of a test piece, for hardness testing, is 6 mm.

NOTE 3 For upper hardness testing, sections of boot leg material may be built up to achieve this minimum thickness.

Table 3 — Limits for hardness of poly(vinyl chloride) compound

Boot component	Hardness at $23\text{ °C} \pm 2\text{ °C}$	
	min.	max.
Upper	42	59
Soling and heel	50	67

Values in IRHD

5.5 Cold flex temperature of the upper

When parts of the upper are tested in accordance with ISO 458-1, applied as indicated below, the cold flex temperature shall be not higher than -35 °C .

Two test pieces shall be used, cut such that the major axis of one test piece was aligned up the leg of the boot and that of the other across it.

A graph shall be prepared showing the relationships between deflection and temperature, and from this the temperature at an angle of 200° deflection of

each test piece shall be determined. A deduction of $0,5\text{ °C}$ shall be made for each 0,03 mm of the thickness of a test piece above 1,30 mm, and an addition of $0,5\text{ °C}$ shall be made for each 0,03 mm of the thickness below 1,27 mm. The arithmetic mean of the two results shall be recorded as the cold flex temperature of the part under test.

5.6 Resistance of soling to cut growth (flexing test)

When parts of the soling are tested in accordance with annex C at a temperature of $-5\text{ °C} \pm 2\text{ °C}$, using three test pieces cut parallel to the centreline of the sole (see figure 1), the thickness of the soling compound shall not be less than 50 % of the test piece thickness and the number of flexing cycles to achieve 6 mm cut growth shall be not less than 150 000 for each test piece when the measurements of cut growth are confined to the outside surface of the test piece.

5.7 Volatility of upper and soling compounds

When tested in accordance with ISO 176 using test pieces of poly(vinyl chloride) compound $2,0\text{ mm} \pm 0,1\text{ mm}$ in thickness taken from the upper and soling components, respectively, the mean loss in mass of the three test pieces shall not exceed 2,0 % for either the upper or the soling compound.

6 Marking

Each article of footwear shall be indelibly and legibly marked with the following:

- the size, stamped on the inside or moulded on the waist of the outsole;
- the manufacturer's or supplier's identification including the name, trademark or other means of identification of the country of manufacture, distributor or retailer;
- the reference number of this International Standard.

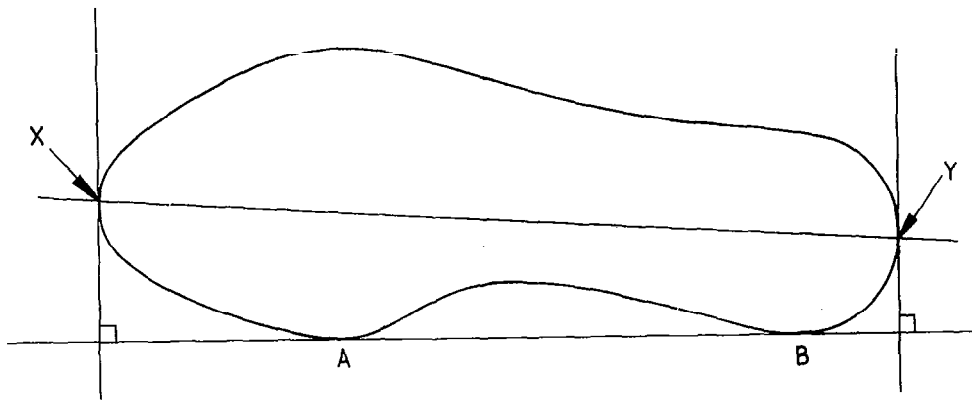

Figure 1 — Centreline of the boat

Annex A (normative)

Measurement of thickness

A.1 Apparatus

Measuring devices appropriate to the part of the boot being measured are classified and listed in table A.1. Devices classified as "accurate" may always be used if desired. Those classified as "routine" may be used unless the readings obtained fall within 10 % of the specified minimum value for the component being measured; in such cases, the component shall be measured using the appropriate "accurate" device.

A.2 Preparation of boots for measurements of thickness

A.2.1 Preparation for measurement of insole and boot bottom

Cut the boot longitudinally and perpendicular to the surface, through the centre of the sole, on a line drawn from the centre of the toecap to the centre of the heel.

Locate the centreline, illustrated in figure 1, by placing the boot on a horizontal surface and against a vertical plane so that it touches the edge of the sole at points A and B on the inner side of the boot.

Construct two further vertical planes at right angles to the first vertical plane so that they meet the sole at points X and Y. Draw a line through X and Y. This line shall constitute the centreline for the forepart of the boot.

A.2.2 Preparation for measurement of foxing

Cut horizontally through the foxing right round the upper at a distance of 13 mm above the top surface of the insole adjacent to the upper.

A.3 Procedure

A.3.1 Boot upper

Take four measurements of the combined thickness of poly(vinyl chloride) and fabric symmetrically round the top of the boot not less than 3 mm and not more than 15 mm below the top binding. In the case of a boot with a hip top extension, take the measurements not less than 3 mm and not more than 15 mm below the joint strip.

Measure the thickness of the coating on the upper from the coating surface to the "peaks" of the fabric weave structure which are nearest to this surface.

Table A.1 — Thickness measuring devices for various components of the boot

Boot component	Class of measuring equipment	
	Routine	Accurate
Upper (full thickness)	Thickness dial gauge calibrated in 0,1 mm, or graduated eyepiece with 0,1 mm scale spacing	Thickness dial gauge in accordance with ISO/R 463, using a pressure of 2 kPa
Upper (coating thickness)	Graduated eyepiece with 0,1 mm scale spacing	Travelling microscope reading to 0,02 mm
Foxing	Graduated eyepiece with 0,1 mm scale spacing	Travelling microscope reading to 0,02 mm
Boot bottom	Graduated rule with scale marks for reading to 1 mm	Graduated eyepiece with 0,1 mm scale spacing

A.3.2 Foxing at the toe

Measure the combined thickness of poly(vinyl chloride) and fabric, excluding any pattern, on the cut section, within 6 mm of the centreline of the boot at the toe.

When a protective toecap is incorporated in the boot, measure the combined thickness of the poly(vinyl chloride) and fabric, excluding any pattern, from the outside surface of the protective toecap.

A.3.3 Foxing at the heel

Measure the combined thickness of poly(vinyl chloride) and fabric, excluding any pattern, on the cut section, within 6 mm of the centreline of the heel.

A.3.4 Foxing in other areas

Take four measurements of the combined thickness of poly(vinyl chloride) and fabric, excluding any pattern, on the cut section, at points symmetrically round the boot in the foxing area but not in either the heel or toe areas.

A.3.5 Full thickness of the boot bottom

Measure the thickness of the boot bottom on the cut section from the upper surface of the insole to the outer surface of the outsole. Take the measurements both over and between cleats, including any pattern, at three separated points in the tread region. Exclude any insock that may be inserted after the boot is moulded.

A.3.6 Outsole

Measure the thickness of the outsole on the cut section, both over and between cleats, including any pattern, from the lower surface of the insole, filler or steel midsole (whichever is the lowest) to the outer surface of the outsole. Take three measurements at different points in the tread region.

A.3.7 Heel

Measure the full heel thickness DE, as illustrated in figure A.1, on the cut section over any cleat or pattern perpendicularly from the upper surface CD of the insole and filler where the insole line CD is 10 mm in length from point C which is at the top of the back edge of the heel on the outside.

Where there is a filler block present, measure the thickness from the underside of the block to the surface of the heel. Take the measurements both over and between cleats, at three positions for each, or at as many positions as the heel design will allow if three is impossible.

A.4 Expression of results

Record each individual test result, for each component, in millimetres to the nearest 0,1 mm.

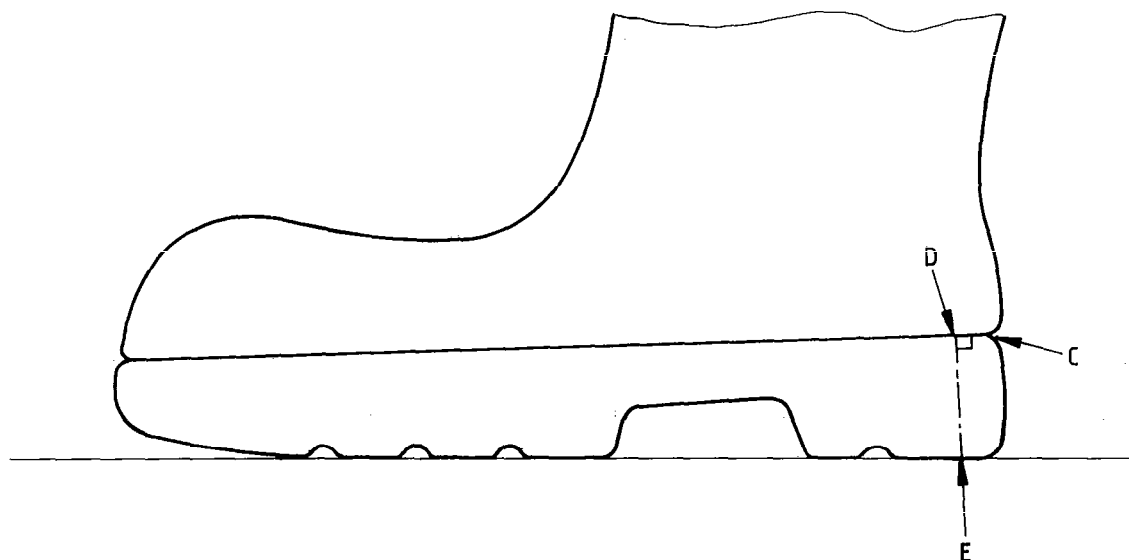

Figure A.1 — Measurement of heel thickness

Annex B (normative)

Determination of the resistance to flexing of the upper material

B.1 Principle

Double creases similar to those formed in the upper of a boot during wear are generated repeatedly in specimens of poly(vinyl chloride) upper material by means of a suitable apparatus until cracking of the poly(vinyl chloride) upper material is observed or until the test pieces survive a specified number of flexure cycles.

B.2 Apparatus (see figure B.1)

The apparatus consists of pairs of V-shaped clamps suitably mounted so that the axes of each pair are in the same straight line.

The angle of each V-clamp is $40^\circ \pm 1^\circ$.

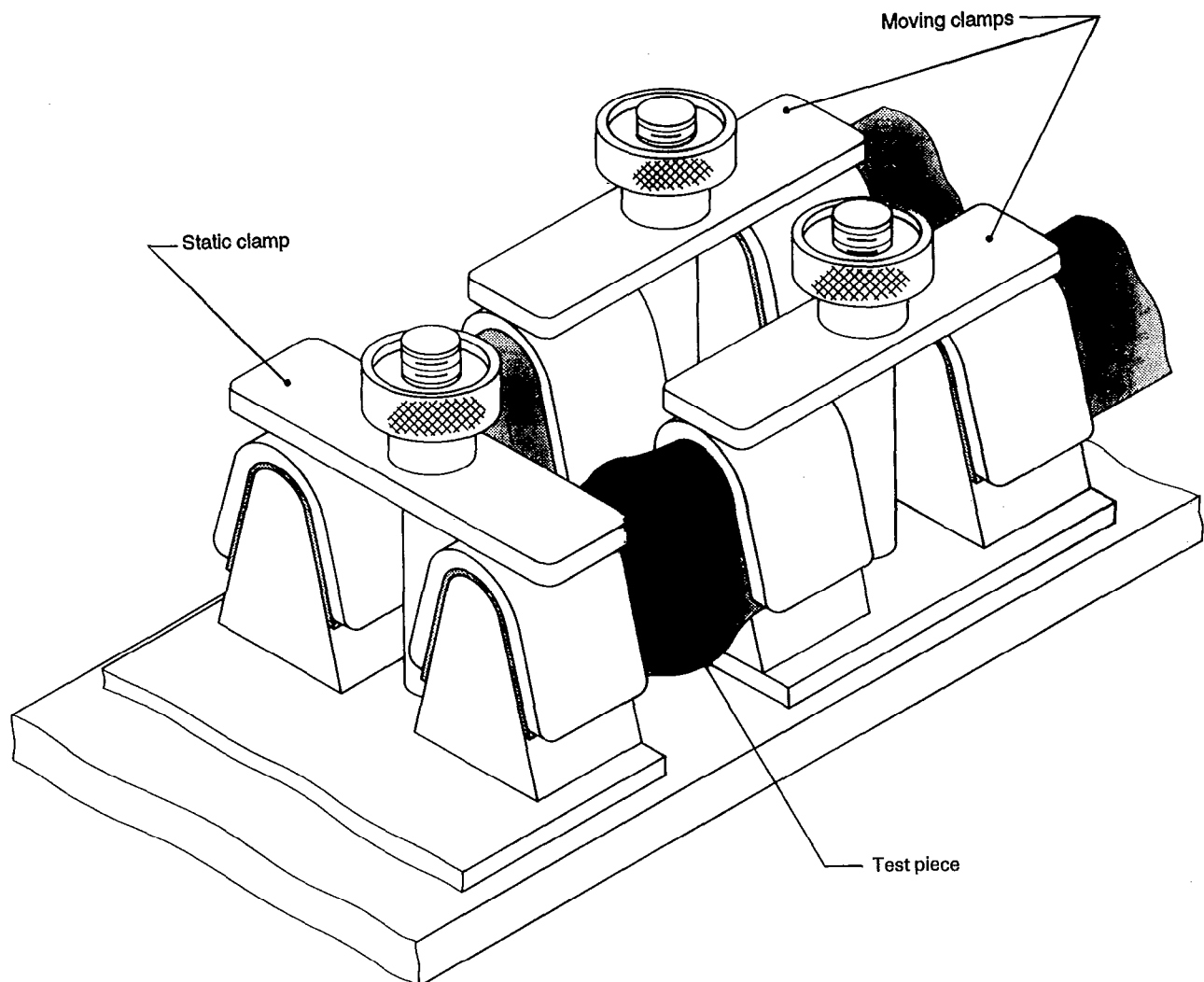

Figure B.1 — Typical apparatus for determination of resistance to flexing

The tips of each V-clamp are rounded to a radius of $6,4 \text{ mm} \pm 0,5 \text{ mm}$. One of the clamps of each pair is capable of reciprocating at a frequency of $5 \text{ Hz} \pm 0,5 \text{ Hz}$ under normal conditions and at a frequency of $1,5 \text{ Hz} \pm 0,2 \text{ Hz}$ when low-temperature testing at $-5 \text{ }^\circ\text{C}$. The clamps are $28,5 \text{ mm} \pm 2,5 \text{ mm}$ apart in the open position and $9,5 \text{ mm} \pm 1,0 \text{ mm}$ apart in the closed position. The stroke of movement of the moving clamp is $19 \text{ mm} \pm 1,5 \text{ mm}$. Alternative dimensions, should the above apparatus be modified to accommodate a larger test piece of $70 \text{ mm} \pm 1 \text{ mm}$ length, can be as follows:

distance between the clamps in the closed position: $13 \text{ mm} \pm 0,5 \text{ mm}$;

distance between the clamps in the open position: $40 \text{ mm} \pm 1 \text{ mm}$;

stroke: $27 \text{ mm} \pm 0,5 \text{ mm}$.

B.3 Preparation of test pieces

Cut, from the thinnest part of the upper, two squares, each of side $64 \text{ mm} \pm 1 \text{ mm}$. Mark the vertical direction with an arrow on each.

B.4 Conditioning and temperature of test

Condition the test pieces for 24 h at $23 \text{ }^\circ\text{C} \pm 2 \text{ }^\circ\text{C}$ and test in air at $-5 \text{ }^\circ\text{C} \pm 2 \text{ }^\circ\text{C}$ so that the test is carried out not less than 7 days after moulding.

B.5 Procedure

Place all the test pieces in a refrigerated cabinet at $-5 \text{ }^\circ\text{C} \pm 2 \text{ }^\circ\text{C}$ and begin loading them immediately. Fit the test pieces into the apparatus with a pair of clamps in the "open" position. Position the specimen, coating outwards, symmetrically in the pair of

clamps so that its side edges are parallel to the axis of the clamps. Check that the inner edges of the two halves of each clamp are in line. Fit other test pieces in a similar manner. Clamp one test piece of each pair with the marked arrow parallel to the flexing direction and one at right angles to it.

Move the clamps together by hand and check that each test piece folds with an inward crease symmetrically across it, surrounded by a diamond of four outward creases.

If necessary, assist the formation of this crease pattern by hand.

Ten minutes after loading has commenced, set the apparatus in motion and stop the test if unacceptable cracking, as defined in B.6, occurs or when the specified number of cycles has been reached if no such cracking has occurred by that time. Record the temperature of test and whether or not cracking has occurred for individual test pieces.

B.6 Relevant types of cracking

Account shall be taken of cracking of the poly(vinyl chloride) that originates at the backing fabric but progresses towards the outer surface of the poly(vinyl chloride), and of all cracking that originates at the outer surface of the poly(vinyl chloride). Any failure of any poly(vinyl chloride) material that may be present between this fabric and the inner surface of the test piece shall be disregarded.

B.7 Expression of results

If all the test pieces reach the specified number of cycles without cracking occurring, the report shall state that the test pieces have passed the test.

If cracking occurs before the specified number of cycles have been completed, the report shall state that the test pieces have failed the test.

Annex C (normative)

Resistance to cut growth (flexing test)

C.1 Principle

The test gives a measure of the resistance of soling material to cracking resulting from flexing in wear. The material is repeatedly flexed through $90^\circ \pm 2^\circ$ over a mandrel after a small cut has been made right through it with a chisel. The rate of growth of this cut is a measure of the tendency of the material to crack.

C.2 Apparatus

C.2.1 Flexing machine (Satra Ross type), having a flexing mechanism as shown in figure C.1.

The test piece A is inserted against the end stop of the flexing arm B and held by the clamp C in which length JK is $50 \text{ mm} \pm 5 \text{ mm}$. The other end of the test piece is not clamped but moves in and out between rollers D, E and F as the test piece is flexed. The flexing takes place round mandrel H which has a radius of curvature of $5,0 \text{ mm} \pm 0,3 \text{ mm}$.

The distance in plan between the vertical tangent to this mandrel through point G and the adjacent edge J of clamp C is $11,0 \text{ mm} \pm 1,5 \text{ mm}$. The chisel cut previously made in the test piece is positioned vertically above the edge of the mandrel when the test piece is in the unflexed position, i.e. at point G in figure C.1. At the coincidence of the cut and the mandrel edge, the tolerance is $\pm 0,5 \text{ mm}$.

The tops of rollers E and F and mandrel H are in the same horizontal plane and roller D is vertically above roller E. Except for this, the dimensions and positions of rollers D, E and F are not critical. A suitable diameter for rollers D and E is 25 mm and for roller F is 10 mm or 15 mm. A suitable distance in plan between the centres of rollers D and E and the centre of curvature of mandrel H is 30 mm, and between the centres of rollers D and E and the centre of roller F is 25 mm or 30 mm. The vertical position of roller D is adjustable so that the gap between this and roller E can accommodate test

pieces of various thickness. A locking mechanism is provided to ensure that the gap cannot change during a test.

Roller F has two adjustable collars L. Their purpose is to help to position the unclamped end of the test piece during insertion in the apparatus, so that the test piece is at right angles to the flexing mandrel in plan, and to guide it in that position during flexing. The difference between the internal and external diameter of each collar shall be about 10 mm. For the standard test piece, the distance between the collars shall be from 25,5 mm to 26,0 mm.

The frequency of flexing shall be $1,0 \text{ Hz} \pm 0,1 \text{ Hz}$.

C.2.2 Refrigerated cabinet, capable of being maintained at $-5^\circ \text{C} \pm 2^\circ \text{C}$. The driving motor of the flexing machine (C.2.1) shall be outside the cabinet.

C.2.3 Piercing chisel, to produce the initial cut in the test pieces, as illustrated in figure C.2. The cutting edge is 2 mm long, but it is usual for the length of cut produced in the material to differ a little from this. The insertion of the cut in the correct position is made easier by holding the chisel in a cutting jig.

C.3 Preparation of test pieces

The standard test piece is 25 mm wide by 150 mm long by $5,0 \text{ mm} \pm 0,2 \text{ mm}$ thick. Test three pieces from the soling material. Remove any pattern and reduce the thickness of the test pieces to a standard thickness by cutting and very light buffing of both sides of the test piece. Pierce each test piece, making the cut in the wearing (outer) surface, approximately 60 mm from one end, so that the length of the cut is symmetrical across the centreline of the test piece. The chisel (C.2.3) shall penetrate right through the test piece and protrude 15 mm on the other side. An adjustable collar may be fitted to the chisel shank to control the penetration distance of the chisel.

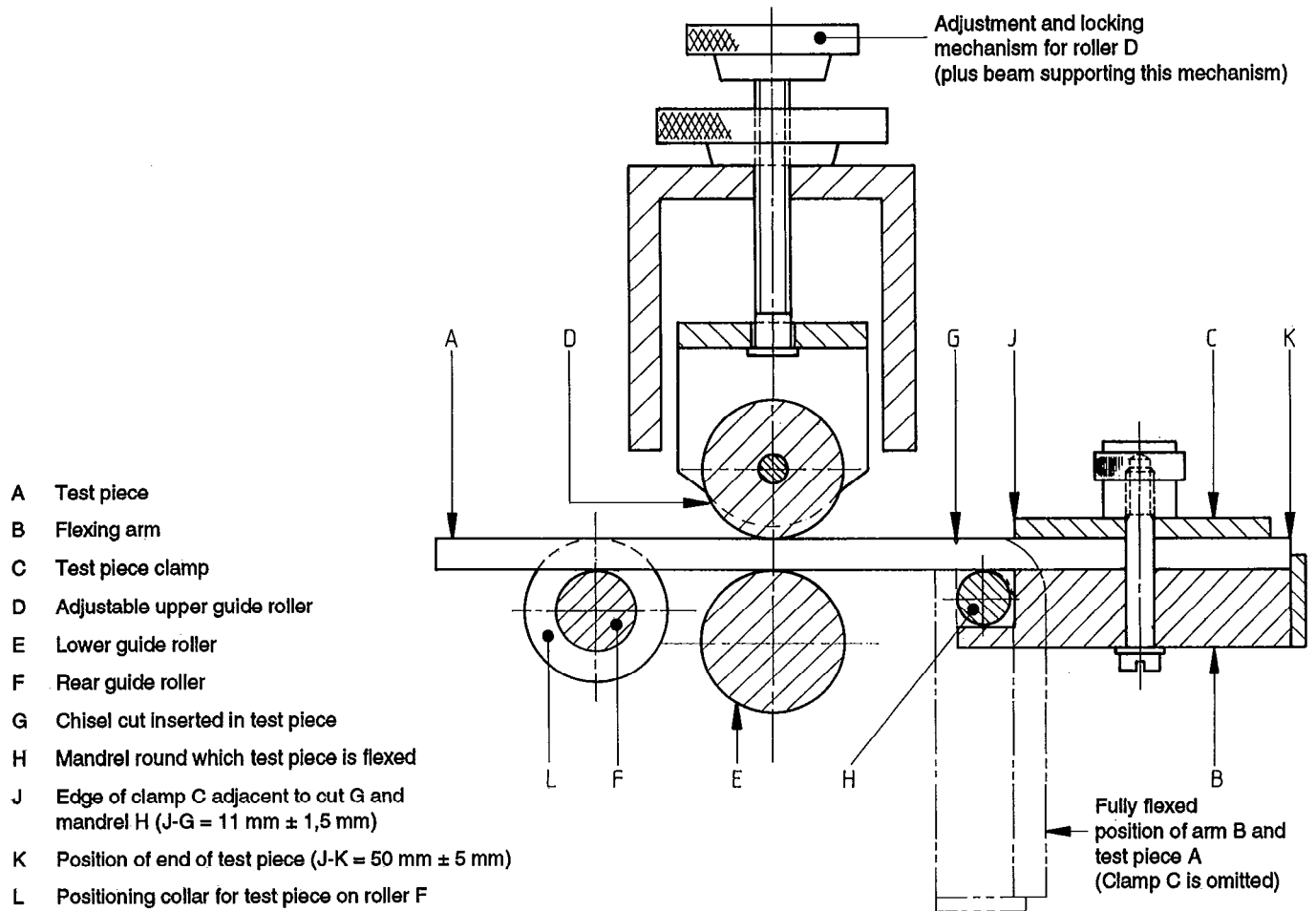

a) Side view of test piece, flexing arm and guide rollers

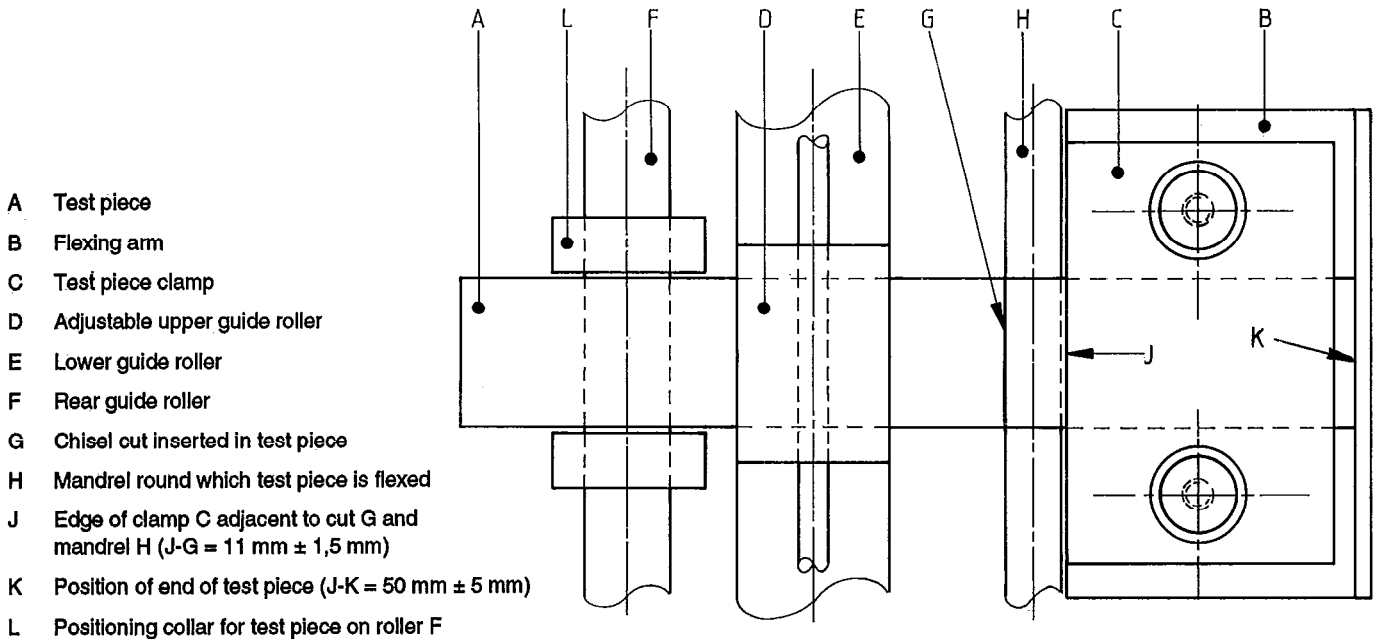

b) Plan view of test piece, flexing arm and guide rollers

NOTE — For clarity, the adjustment and locking mechanism for roller D [see figure C.1 a)] has been omitted.

Figure C.1 — Flexing machine

Dimensions in millimetres

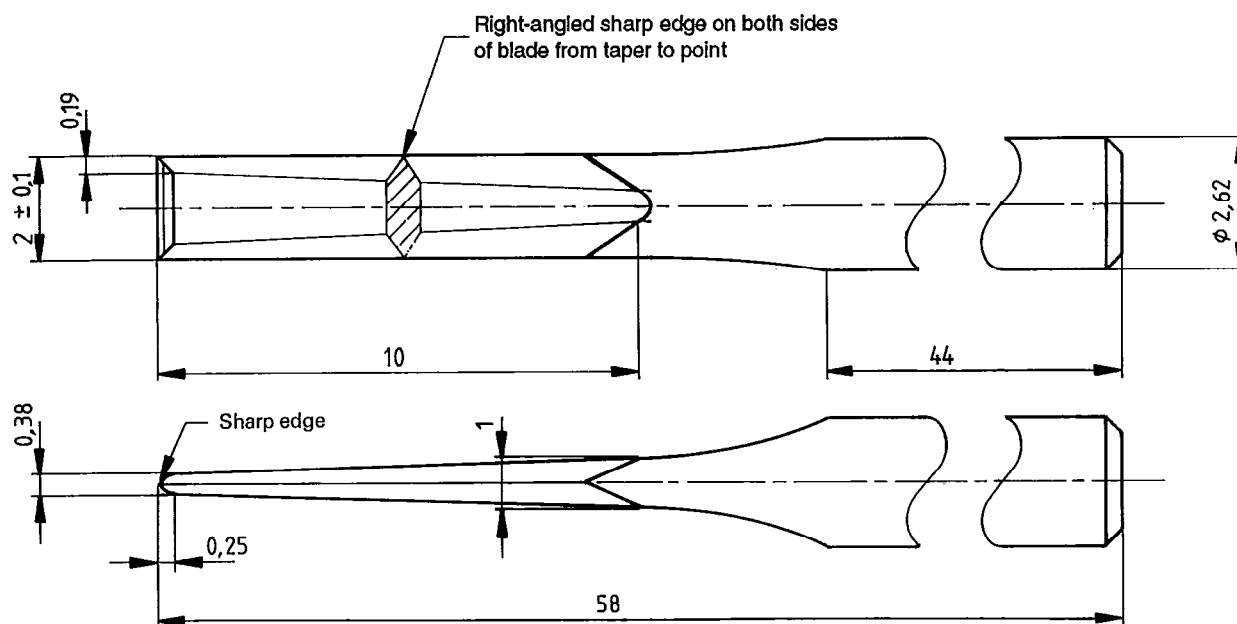

Figure C.2 — Piercing chisel

C.4 Conditioning and temperature of test

Condition the test pieces for 24 h at $23\text{ °C} \pm 2\text{ °C}$ and test at a temperature of $-5\text{ °C} \pm 2\text{ °C}$. The test shall not be carried out less than 96 h after moulding.

C.5 Procedure

Make a preliminary check of the rate of flexing of the machine (C.2.1) to ensure that it runs at the correct speed.

Measure and record the initial length of the cut in each test piece to an accuracy of 0,1 mm. This may most conveniently be done by using a magnifying eyepiece and scale with the test piece bent through 45° round a 15 mm diameter mandrel.

Turn the drive wheel of the flexing machine manually until the flexing arm B is horizontal. Raise the top roller D by slackening the knurled knobs which secure the top frame of the machine. Slacken each clamping plate C. Insert each test piece, wearing surface uppermost, from the back of the machine (the flexing arm B is assumed to be at the front) so that it passes between rollers D and E and then between the clamp C and flexing arm B and abuts against the end stop of B. Roller F and the flexing arm B are both recessed so as to assist in positioning the strip test pieces. Clamp C holds two test pieces, one on each side of the centre screw which fixes it to arm B. Check that the cut in each test

piece is vertically above the edge of mandrel G, then tighten clamp C, making sure that it is parallel to the edge of the flexing arm. Should only one test piece be held in a particular clamp, insert a small piece of the same material in the recess on the other side of the clamp so that the surface of the clamp remains parallel to the surface of the flexing area when it is tightened. Screw down roller D so that it just touches, but does not grip, the test piece. Lock this roller by tightening the wing-nut, which is on the same screw thread, against the frame of the machine.

Flexing shall be started immediately the test piece is mounted, since the test pieces will always be at a higher running temperature than the cabinet because of heating by flexing, and it has been found better for the test piece to cool to this running temperature during the initial part of the test than for it to start colder, and then warm up.

After the flexing has been started, inspect the test pieces at frequent intervals (say every hour initially) for evidence of any increase in length of the initial cut, or of new cracks forming.

To do this, remove all the test pieces from the cabinet, measure the crack lengths after bending through 45° round a 15 mm mandrel, and then replace all the test pieces as described under the initial loading procedure.

If for any reason flexing is discontinued, remove the test pieces from the machine.

Flexing shall be continued

- a) either until the initial cut has increased by 6 mm or more;
- b) or until the test pieces have flexed for the specified number of cycles without the initial cut increasing in length by 6 mm.

In case a), it is usually impossible to observe the number of flexure cycles when the amount of cut growth is exactly 6 mm but it should be possible to make observations when it is a little less and a little more than this value. The number of cycles for 6 mm growth can then be obtained by interpolation either graphically or arithmetically.

In case b), measure the length of the crack after the specified number of cycles and calculate the amount of cut growth.

Record the temperature of test.

C.6 Expression of results

If the end point of the test is reached before the specified number of cycles, express the result as the number of cycles for the cut to increase in length by 6 mm.

If the test reaches the specified number of cycles (i.e. the cut does not increase in length by 6 mm after this number of flexure cycles), express the result as the increase in cut length after the specified number of cycles.

Annex D (informative)

Boot heights

Suggested ranges for the height of boots covered by this International Standard are given in table D.1. The height should be measured on the inside at the back of the boot from the insole to the top, including any flexible extension.

Table D.1 — Boot heights

Dimensions in millimetres

Measurement	Height	
	Men's	Women's
Ankle	115 to 179	115 to 152
Half knee	180 to 239	153 to 203
Short knee	240 to 329	204 to 279
Knee	330 to 429	280 to 380
Three-quarter thigh	640 to 699	—
Full thigh	700 min.	—

NOTE 4 Agreement between the interested parties on the nominal boot height and permitted tolerances is common commercial practice.

UDC 685.312.22/.24:613.6:678.743.22.067

Descriptors: plastics products, polyvinyl chloride, footwear, boots, specifications, dimensions, tests, marking.

Price based on 13 pages
