

---

---

**Paints and varnishes — Determination  
of resistance to filiform corrosion —**

**Part 2:  
Aluminium substrates**

*Peintures et vernis — Détermination de la résistance à la corrosion  
filiforme —*

*Partie 2: Subjectiles en aluminium*



**COPYRIGHT PROTECTED DOCUMENT**

© ISO 2016, Published in Switzerland

All rights reserved. Unless otherwise specified, no part of this publication may be reproduced or utilized otherwise in any form or by any means, electronic or mechanical, including photocopying, or posting on the internet or an intranet, without prior written permission. Permission can be requested from either ISO at the address below or ISO's member body in the country of the requester.

ISO copyright office  
Ch. de Blandonnet 8 • CP 401  
CH-1214 Vernier, Geneva, Switzerland  
Tel. +41 22 749 01 11  
Fax +41 22 749 09 47  
copyright@iso.org  
www.iso.org

# Contents

Page

Foreword .....	iv
Introduction .....	v
<b>1 Scope .....</b>	<b>1</b>
<b>2 Normative references .....</b>	<b>1</b>
<b>3 Terms and definitions .....</b>	<b>1</b>
<b>4 Principle .....</b>	<b>2</b>
<b>5 Sampling .....</b>	<b>2</b>
<b>6 Apparatus .....</b>	<b>2</b>
<b>7 Reagents .....</b>	<b>2</b>
<b>8 Test panels .....</b>	<b>2</b>
8.1 Material and dimensions .....	2
8.2 Preparation and coating .....	3
8.3 Drying and conditioning .....	3
8.4 Thickness of coating .....	3
<b>9 Procedure .....</b>	<b>3</b>
9.1 Determination .....	3
9.2 Scribing the test panels .....	3
9.3 Testing .....	5
9.4 Inspection of test panels .....	5
<b>10 Evaluation of the degree of filiform corrosion .....</b>	<b>5</b>
<b>11 Precision .....</b>	<b>5</b>
<b>12 Test report .....</b>	<b>5</b>
<b>Bibliography .....</b>	<b>7</b>

## Foreword

ISO (the International Organization for Standardization) is a worldwide federation of national standards bodies (ISO member bodies). The work of preparing International Standards is normally carried out through ISO technical committees. Each member body interested in a subject for which a technical committee has been established has the right to be represented on that committee. International organizations, governmental and non-governmental, in liaison with ISO, also take part in the work. ISO collaborates closely with the International Electrotechnical Commission (IEC) on all matters of electrotechnical standardization.

The procedures used to develop this document and those intended for its further maintenance are described in the ISO/IEC Directives, Part 1. In particular the different approval criteria needed for the different types of ISO documents should be noted. This document was drafted in accordance with the editorial rules of the ISO/IEC Directives, Part 2 (see [www.iso.org/directives](http://www.iso.org/directives)).

Attention is drawn to the possibility that some of the elements of this document may be the subject of patent rights. ISO shall not be held responsible for identifying any or all such patent rights. Details of any patent rights identified during the development of the document will be in the Introduction and/or on the ISO list of patent declarations received (see [www.iso.org/patents](http://www.iso.org/patents)).

Any trade name used in this document is information given for the convenience of users and does not constitute an endorsement.

For an explanation on the meaning of ISO specific terms and expressions related to conformity assessment, as well as information about ISO's adherence to the World Trade Organization (WTO) principles in the Technical Barriers to Trade (TBT) see the following URL: [www.iso.org/iso/foreword.html](http://www.iso.org/iso/foreword.html).

The committee responsible for this document is ISO/TC 35, *Paints and varnishes*, Subcommittee SC 9, *General test methods for paints and varnishes*.

This second edition cancels and replaces the first edition (ISO 4623-2:2003), which has been technically revised. It also incorporates the Technical Corrigendum ISO 4623-2:2003/Cor 1:2005. The following main changes have been made:

- a) duplicate determination has been changed to triplicate determination;
- b) information on the shape of the scribe marks has been added;
- c) the width of the scribe marks has been changed to be in line with EN 3665;
- d) a note on using the CASS test for initiating filiform corrosion was added;
- e) the supplementary test conditions previously in Annex A have been integrated in the test report.

ISO 4623 consists of the following parts, under the general title *Paints and varnishes — Determination of resistance to filiform corrosion*:

- *Part 1: Steel substrates*
- *Part 2: Aluminium substrates*

## Introduction

A scribe mark cut through a coating of paints or varnishes on metal can give rise to various types of corrosion, such as blistering of the coating, corrosion of the metal under the coating as well as filiform corrosion. Filiform corrosion tends to develop under specific conditions of temperature and relative humidity and when traces of acids, bases or salts are present either under the paint coating or at breaks in the coating. These conditions are often found in marine and/or industrial environments. A certain amount of under-corrosion of the coating, starting from the scribe mark, will always occur. Filiform corrosion, however, is considered to be present only if the typical pattern in the form of threads is obvious.



# Paints and varnishes — Determination of resistance to filiform corrosion —

## Part 2: Aluminium substrates

### 1 Scope

This part of ISO 4623 describes a test procedure for assessing the protective action of coatings of paints or varnishes on aluminium against filiform corrosion arising from a scribe mark cut through the coating.

It is only suitable for assessing the performance of the coating/substrate combination tested. It is not suitable for predicting the performance of the coating on different substrates.

### 2 Normative references

The following referenced documents, in whole or in part, are normatively referenced in this document and are indispensable for its application. For dated references, only the edition cited applies. For undated references, the latest edition of the referenced document (including any amendments) applies.

ISO 1513, *Paints and varnishes — Examination and preparation of test samples*

ISO 1514, *Paints and varnishes — Standard panels for testing*

ISO 2808, *Paints and varnishes — Determination of film thickness*

ISO 3270, *Paints and varnishes and their raw materials — Temperatures and humidities for conditioning and testing*

ISO 4628-8, *Paints and varnishes — Evaluation of degradation of coatings — Designation of quantity and size of defects, and of intensity of uniform changes in appearance — Part 8: Assessment of degree of delamination and corrosion around a scribe or other artificial defect*

ISO 4628-10, *Paints and varnishes — Evaluation of degradation of coatings — Designation of quantity and size of defects, and of intensity of uniform changes in appearance — Part 10: Assessment of degree of filiform corrosion*

ISO 15528, *Paints, varnishes and raw materials for paints and varnishes — Sampling*

### 3 Terms and definitions

For the purposes of this document, the following terms and definitions apply.

#### 3.1 filiform corrosion

type of corrosion proceeding under a coat of paint, varnish or related product, in the form of threads, generally starting from bare edges or from local damage to the coating

Note 1 to entry: Usually the threads are irregular in length and direction of growth, but they may also be nearly parallel and of approximately equal length. They usually follow the extrusion direction and do not cross over one another. They need to be initiated by aggressive ions.

## 4 Principle

A coated test panel is scribed as defined in 9.2. A small amount of hydrochloric acid is introduced into the scribe mark through exposure to hydrochloric acid vapour. The panel is then exposed in a test cabinet at 40 °C and a relative humidity of 82 %. The effects of exposure are then evaluated by criteria agreed in advance between the interested parties; these criteria usually being either of a subjective nature or as given in ISO 4628-10.

## 5 Sampling

Take a representative sample of the product to be tested (or of each product in the case of a multi-coat system), as specified in ISO 15528.

Examine and prepare each sample for testing, as specified in ISO 1513.

## 6 Apparatus

Ordinary laboratory apparatus and glassware, together with the following:

**6.1 Test cabinet**, capable of being maintained at  $(40 \pm 2)$  °C and a relative humidity of  $(82 \pm 5)$  %. The cabinet shall have provision for maintaining the panels in a horizontal position (see Note) at least 20 mm apart or, if specified, provision for placing or hanging the test panels in an approximately vertical position so that the distance between the faces of adjacent panels is at least 20 mm.

NOTE Due to the hygroscopic action of the hydrochloric acid in the scribe mark, mixtures of water droplets and hydrochloric acid can be formed. Horizontal exposure will result in more corrosion which proceeds in a more regular manner along the length of each scribe mark.

**6.2 Container**, made of acid-resistant material, with a lid, and capable of holding the test panels at a distance of  $(100 \pm 10)$  mm from the surface of the acid and at least 20 mm from each other.

**6.3 Scribe tool**, consisting of a sharp instrument which will produce scribe marks with the dimensions specified in 9.2 and with well-defined edges. There are many scribe tools available, and the result of the test will vary depending on the tool used. A description of the scribe tool shall be given in the test report [see Clause 12, item d)].

**6.4 Ruler**, accurate to 1 mm.

## 7 Reagents

**7.1 Hydrochloric acid**, of analytical grade, concentration 37 % ( $\rho = 1,19$  g/cm<sup>3</sup>).

The quality and purity of the hydrochloric acid shall be kept constant.

## 8 Test panels

### 8.1 Material and dimensions

The test panels shall be of aluminium complying with the requirements of ISO 1514 and of minimum dimensions 100 mm × 70 mm × 0,8 mm, unless otherwise specified, the short dimension being in the direction of rolling of the metal.



## 8.2 Preparation and coating

Prepare the test panels as described in ISO 1514, unless otherwise specified, and then coat them by the specified method with the product or system under test.

Unless otherwise specified, the back and edges of the panel shall also be coated with the product or system under test.

If the coating on the back and edges of the panel differs from that of the product under test, it shall have corrosion resistance greater than that of the product under test.

## 8.3 Drying and conditioning

Dry (or stove) and age (if applicable) each coated test panel for the specified time under the specified conditions, and, unless otherwise specified, condition them at the standard temperature and relative humidity defined in ISO 3270 for at least 16 h, with free circulation of air and without exposing them to direct sunlight. The test procedure shall then be carried out as soon as possible.

## 8.4 Thickness of coating

Determine the thickness, in micrometres, of the dried coating by one of the non-destructive procedures described in ISO 2808.

# 9 Procedure

## 9.1 Determination

Carry out all tests in triplicate unless otherwise agreed.

## 9.2 Scribing the test panels

Unless otherwise specified, make two scribe marks, each at least 30 mm long, on each test panel, making the scribe marks perpendicular to each other. The distance between the scribe marks and from the scribe marks to the edge of the panel shall be at least 20 mm (see [Figure 1](#)). The scribe marks shall be of width 1 mm to 2 mm (see [Figure 2](#)), unless otherwise agreed.

Remove the debris from the scribe marks. The coating shall be smooth at the edges of the scribe mark. Ensure that the metal is clearly visible over the entire length of the scribe marks by using a magnifying glass of  $\times 10$  magnification.

If the aluminium has surface cladding, then the scribe mark shall penetrate through the cladding layer by 0,05 mm to 0,1 mm (see [Figure 2](#)).

Different scribing devices produce different amounts of corrosion in the scribe mark, therefore the manner of scribing and the type of tool used shall be reported.

Dimensions in millimetres

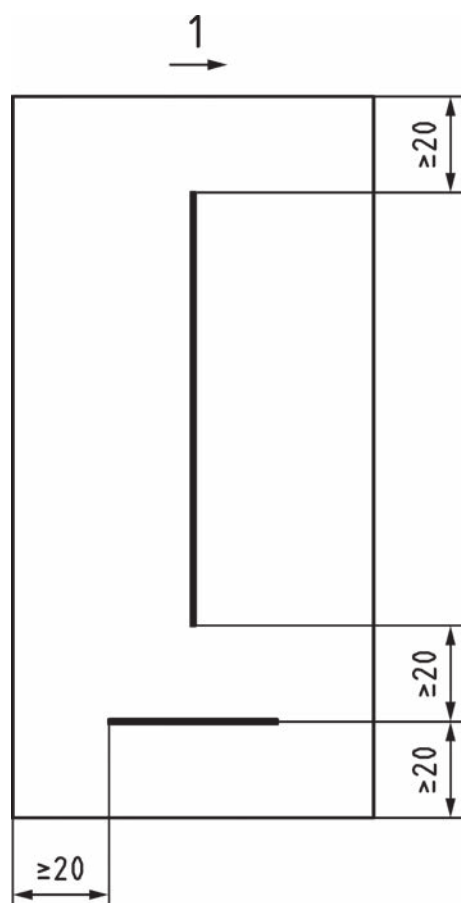

**Key**  
 1 rolling direction

**Figure 1 — Positions of scribe marks**

Dimensions in millimetres

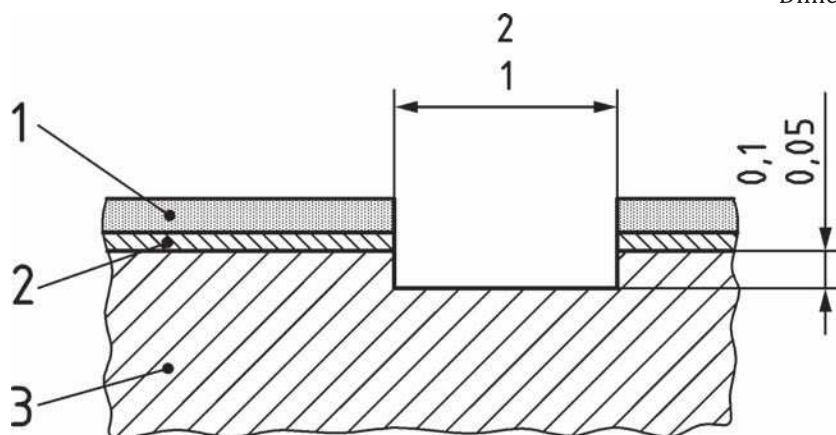

**Key**  
 1 coating  
 2 cladding  
 3 substrate

**Figure 2 — Shape of the scribe marks**

### 9.3 Testing

Into the container (6.2), place  $(20 \pm 2)$  ml of hydrochloric acid (7.1) per litre of container volume.

NOTE For some materials, the CASS test specified in ISO 9227 has been found suitable for initiating the filiform corrosion process at a higher rate.

Place the test panels in the container, face down above the liquid, with the scribe marks exposed to the vapour. The distance between the test panels and the surface of the liquid shall be  $(100 \pm 10)$  mm, and they shall be at least 20 mm apart from each other. The position of the test panels during exposure in the test cabinet (horizontal or vertical) has an influence on the test result, and therefore it shall be noted.

Place the lid on the container and keep at a temperature of  $(23 \pm 2)$  °C for  $(60 \pm 5)$  min. Remove the test panels, allow them to stand at the standard conditions defined in ISO 3270 for 15 min to 30 min and then immediately place them in the test cabinet (6.1) at  $(40 \pm 2)$  °C and  $(82 \pm 5)$  % relative humidity until the end of the specified test period.

It is recommended that a control specimen prepared from a paint of known durability be included with each series of test panels.

### 9.4 Inspection of test panels

Where appropriate, at the specified intervals and on completion of the test, inspect the test panels for filiform corrosion (see Clause 10). During inspection, the panels shall not be allowed to remain out of the cabinet for more than 30 min, as a longer time may affect the development of the filiform corrosion.

If the coating is removed (by stripping) at specified intervals, make sure that enough test panels are placed in the cabinet at the beginning of the test.

## 10 Evaluation of the degree of filiform corrosion

Using the ruler (6.4), determine the length of the longest filament  $L$  and the most frequent filament length  $M$  as described in ISO 4628-10.

Report the results for the two scribe marks separately, as the scribe mark which is perpendicular to the rolling direction will show much more and longer filiform corrosion.

If specified, determine corrosion other than filiform about the scribe marks as described in ISO 4628-8.

If specified, remove the coating with a non-corrosive paint remover and re-examine the substrate.

Photographs of the test panels taken at the end of the test may be helpful in assessing the extent of the filiform corrosion.

## 11 Precision

No relevant precision data are currently available.

ISO/TC 35 intends to obtain precision data for all relevant standards, including this part of ISO 4623. When precision data are available, they will be incorporated in this part of ISO 4623.

## 12 Test report

The test report shall contain at least the following information:

- a) all details necessary to identify the product tested;
- b) a reference to this part of ISO 4623, i.e. ISO 4623-2;

- c) details of the preparation of the test panels, including
  - 1) the material, the thickness and the surface preparation of the substrate (see [8.1](#) and [8.2](#)),
  - 2) the method of application of the coating material to the substrate, including the duration and conditions of drying between coats in the case of a multi-coat system including details on sealing of the edges and backs of the test panels (if required) (see [8.2](#)),
  - 3) the duration and conditions of drying (or stoving) and ageing (if applicable) of the coating before testing (see [8.3](#)),
  - 4) the thickness, in micrometres, of the dry coating and the method of measurement used in ISO 2808, and whether it is a single coating or a multi-coat system (see [8.4](#));
- d) a description of the scribe tool used and the dimensions and location of each scribe mark (see [9.2](#));
- e) whether the panels are to be placed horizontally or vertically in the test cabinet (see [9.3](#));
- f) the duration of the test (see [9.3](#)) and the intervals of inspection (see [9.4](#));
- g) the results of the test as indicated in [Clause 10](#);
- h) any deviations (by agreement or otherwise) from the test procedure specified;
- i) any unusual features (anomalies) observed during the test;
- j) the date of the test.

## Bibliography

- [1] ISO 9227, *Corrosion tests in artificial atmospheres — Salt spray tests*
- [2] EN 3665, *Aerospace series — Test methods for paints and varnishes — Filiform corrosion resistance test on aluminium alloys*

