

---

# International Standard 4615

---

INTERNATIONAL ORGANIZATION FOR STANDARDIZATION • МЕЖДУНАРОДНАЯ ОРГАНИЗАЦИЯ ПО СТАНДАРТИЗАЦИИ • ORGANISATION INTERNATIONALE DE NORMALISATION

---

## **Plastics — Unsaturated polyesters and epoxide resins — Determination of total chlorine content**

*Plastiques — Résines de polyesters non saturés et époxydes — Détermination de la teneur totale en chlore*

**First edition — 1979-12-01**

---

**EN ISO 4615:1999****FOREWORD**

ISO (the International Organization for Standardization) is a worldwide federation of national standards institutes (ISO member bodies). The work of developing International Standards is carried out through ISO technical committees. Every member body interested in a subject for which a technical committee has been set up has the right to be represented on that committee. International organizations, governmental and non-governmental, in liaison with ISO, also take part in the work.

Draft International Standards adopted by the technical committees are circulated to the member bodies for approval before their acceptance as International Standards by the ISO Council.

International Standard ISO 4615 was developed by Technical Committee ISO/TC 61, *Plastics*, and was circulated to the member bodies in August 1978.

It has been approved by the member bodies of the following countries :

Austria	Hungary	South Africa, Rep. of
Belgium	Iran	Sweden
Bulgaria	Italy	Switzerland
Canada	Japan	Turkey
Czechoslovakia	Korea, Rep. of	USA
Egypt, Arab Rep. of	Mexico	USSR
Finland	Netherlands	Yugoslavia
Germany, F.R.	New Zealand	
Greece	Romania	

The member body of the following country expressed disapproval of the document on technical grounds :

United Kingdom

# Plastics — Unsaturated polyesters and epoxide resins — Determination of total chlorine content

## 1 SCOPE AND FIELD OF APPLICATION

This International Standard specifies two methods for the determination of the total chlorine content of unsaturated polyesters and epoxide resins, namely :

- method A : combustion in a bomb;
- method B : combustion in a flask.

### NOTES

1 Determination of combined chlorine and bromine content or bromine content only, is also possible by these methods. The appropriate procedure shall be agreed upon by the purchaser and the supplier.

2 These methods are not applicable to the determination of total chlorine in epoxy resins containing chlorine as an impurity.

## 2 PRINCIPLE

Oxidation of a test portion with sodium peroxide (method A) or gaseous oxygen (method B) followed by electrometric or volumetric titration of the resulting chlorides.

## 3 REAGENTS

During the analysis, use only reagents of known analytical quality, and only distilled water or water of at least equivalent purity.

**3.1 Silver nitrate**, standard volumetric solution,  $c(\text{AgNO}_3) = 0,1 \text{ mol/l}$ .<sup>1)</sup>

NOTE — For testing resins of low total chlorine content [less than 2 % (m/m)], a standard volumetric solution of silver nitrate,  $c(\text{AgNO}_3) = 0,05 \text{ mol/l}$ ,<sup>2)</sup> may be used.

**3.2 Nitric acid**, 126 g/l solution.

For method A only :

**3.3 Nitric acid**, concentrated,  $\rho = 1,42 \text{ g/ml}$ .

**3.4 Sodium peroxide**, granulated.

**3.5 Starch or sucrose** as combustion aids.

For method B only :

**3.6 Oxygen**, gaseous.

**3.7 Sodium nitrate**.

**3.8 Potassium hydroxide solution**, 100 g/l.

**3.9 Hydrogen peroxide solution**, 300 g/l.

## 4 APPARATUS

**4.1 Balance**, to weigh to an accuracy of 0,000 1 g.

**4.2 Equipment for Volhard titration or for electrometric titration**, with a burette having a capacity and accuracy appropriate to the chosen method (A or B).

For method A only :

**4.3 Combustion bomb** (for example Parr bomb or another bomb which gives the same results), electrically fired or gas-fired. A suitable gas-fired bomb is shown in figure 1.

**4.4 Nickel crucible with lid**, to fit into the bomb (gas-fired). Suitable dimensions are : diameter 25 mm, height 40 mm.

**4.5 Safety oven**.

1) Hitherto expressed as 0,1 N standard volumetric solution.

2) Hitherto expressed as 0,05 N standard volumetric solution.

EN ISO 4615:1999

Approximate dimensions in millimetres

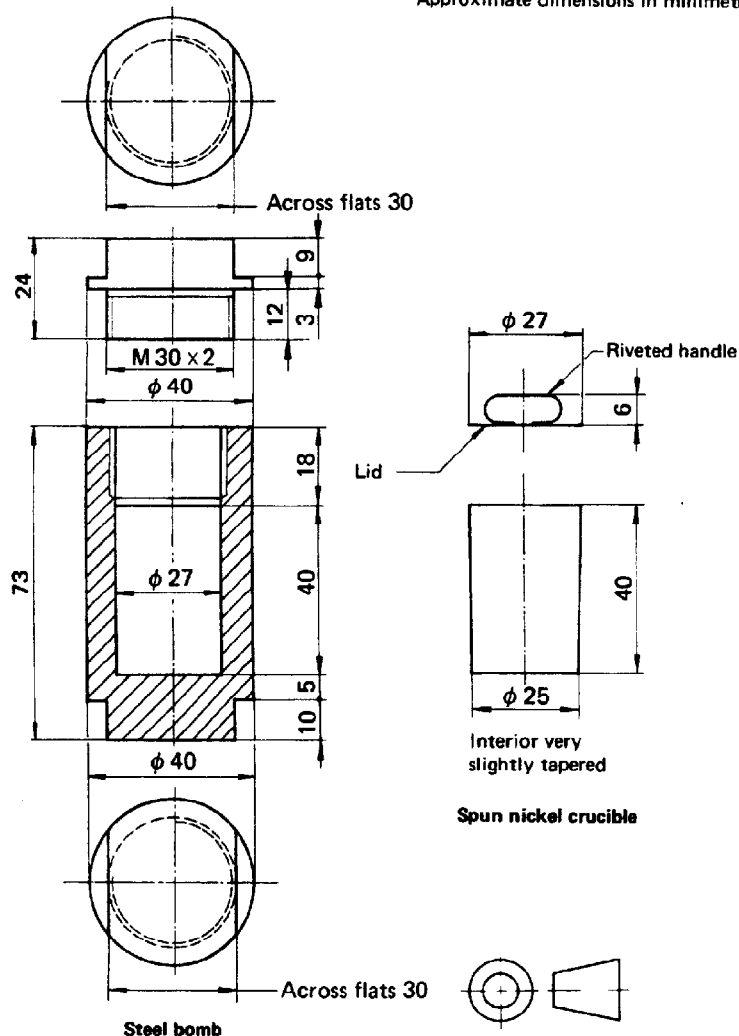

FIGURE 1 – Combustion bomb, gas-fired type (for method A)

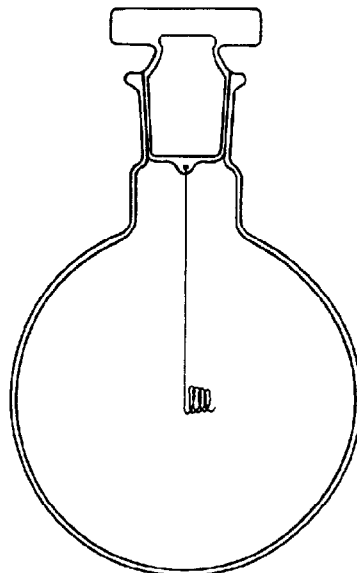

FIGURE 2 – Flask for oxygen combustion with platinum wire attached to stopper (for method B)

**4.6 Beaker, of capacity 600 ml.**

For method B only :

**4.7 Round-bottomed flask** of capacity 500 ml, with head for oxygen combustion (see figure 2). A platinum wire 1 mm in diameter and 120 mm long in the shape of a tapered spiral is attached to the stopper, a suitable spiral being 15 mm in diameter and 15 mm long. It is recommended that metal gauze be wrapped around the flask for safety or that a safety cage be used.

NOTE — A safety bulb can be fitted to the flask to permit expansion of the gases to reduce the hazard.

**4.8 Filter paper, free from halogens and ash.**

**4.9 Adhesive tape** of cellulose acetate or regenerated cellulose, coated with polyvinyl acetate, of width 30 mm.

**4.10 Beaker, of capacity 100 ml.****5 TEST SAMPLE**

If the sample is in the solid state, it shall be in powdered or granular form, or if necessary shall be cut into pieces 1 to 3 mm in size. When an electrically fired bomb is used, it is preferable that the material be powdered.

**6 PROCEDURE****6.1 Method A (combustion bomb)****6.1.1 Test portion**

Weigh, to the nearest 0,000 5 g, 0,1 g maximum of the test sample.

**6.1.2 Determination**

**6.1.2.1** First place 7 to 7,5 g of the sodium peroxide (3.4) in the crucible (4.4) (for the gas-fired bomb), or in the fusion cup of the bomb (for the electrically fired bomb), then add the test portion (6.1.1) mixed with 0,16 to 0,17 g of the starch or sucrose, then an additional 7 to 7,5 g of the sodium peroxide. **The filling with sodium peroxide should be carried out behind a shield protecting the operator.** Mix all components by stirring, then place the crucible, with the lid in position, inside the bomb and close the bomb tightly. If an electrically fired bomb is used, assemble the bomb and tap it to settle the charge.

**6.1.2.2 Fire the bomb.**

**IMPORTANT WARNING —** If a gas-fired bomb is used, place the bomb in the safety oven (4.5). Adjust the flame beforehand, using an empty bomb in the safety oven, so that the top of the flame is a few millimetres from the base of the bomb. Then remove the empty bomb. Heat the test bomb to 300 to 400 °C for about 10 min. Ignition usually starts at 50 to 60 °C, and is detected by a cracking sound, and the fact that the bottom of the bomb starts to glow.

The heating of the bomb is of extreme importance because underheating will cause incomplete oxidation of the organic matter and low chlorine results, whereas overheating may cause damage to the bomb cup and even an explosion.

These bombs are not intended to operate at a red heat, but there is no serious danger involved in this method of oxidation provided that the proper charges are used in a bomb that is in satisfactory condition, and that the proper heating technique is used.

Discard the bomb if the sides or bottom become visibly swollen, or if the interior surfaces become worn or corroded at any point to an inside diameter 1,5 % below the original value.

It is essential to read carefully the manufacturer's instructions, particularly with reference to safety precautions.

**6.1.2.3** Cool the bomb. Open it and, if a gas-fired bomb is used, remove the crucible, carefully place it in 100 ml of water in the beaker (4.6) and immediately cover the beaker with a watch glass. When the reaction has subsided, wash down the inside of the bomb and the plug, collecting the washings in the beaker.

If an electrically fired bomb is used, dismantle it after cooling, remove the head and tip it into 100 ml of water in the beaker (4.6). Lay the fusion cup in the same beaker and immediately cover with a watch glass.

**CAUTION —** If the bomb is cooled in water, take care that the water does not reach the joint between the plug and the bomb.

**IMPORTANT WARNING —** When doubt exists as to whether the reaction has taken place, do not dissolve the contents of the bomb into water according to the normal procedure because this might lead to a violent explosion. The contents of the bomb should be spread out onto dry sand, after which they should be sprayed with water from a safe distance and then washed with more water.

**6.1.2.4** Heat the beaker and its contents to boiling, then cool. Rinse the crucible and lid, or the fusion cup and head, into the beaker with water, then remove them.

**6.1.2.5** Slowly add 20 ml of the concentrated nitric acid (3.3), stirring constantly, followed by the nitric acid solution (3.2) until the mixture is neutral. Then add an additional 2 ml of the nitric acid solution (3.2).

NOTE — Methyl orange is a suitable indicator for the neutralization.

**6.1.2.6** Dilute the contents of the beaker to about 200 ml with water, and determine the chlorine content, by electro-metric titration or by the Volhard method, with the silver nitrate solution (3.1).

**6.1.3 Blank test**

Carry out a blank test by firing the same amount of the sodium peroxide (3.4) and starch or sucrose (3.5) as was used with the test portion, and repeating the procedure (but omitting the test portion) specified in 6.1.2.

**EN ISO 4615:1999**

**6.2 Method B (oxygen flask)**

**6.2.1 Test portion**

**6.2.1.1 CASE OF A LIQUID**

Cut out 30 mm x 30 mm square of adhesive tape (4.9) [see figure 3 a)]. Stick on it a square of filter paper (4.8) with a tail [see figure 3 b)].

Wind it around a glass rod, starting at the side parallel and closer to the tail, so as to form a small cylinder, keeping the filter paper inside [see figure 3 c)].

Close the extremity of the cylinder opposite the tail by flattening and pinching.

Weigh the cylinder to the nearest 0,000 1 g. Then deposit the liquid sample of 0,025 to 0,035 g through the upper end of the cylinder by a tapered pipette. Close this extremity by pinching. Weigh again to the nearest 0,000 1 g.

Introduce the whole system within the platinum spiral of the flask (4.7), with the paper tail protruding. Proceed as in 6.2.2.

**6.2.1.2 CASE OF A SOLID**

Place 0,025 to 0,035 g of the test sample, weighed to the nearest 0,000 1 g, on a filter paper cut as shown in figure 4 a) and having previously marked folds. Then fold the paper as shown in figures 4 b), c) and d) and introduce it within the platinum spiral of the flask (4.7), with the paper tail protruding. Proceed as in 6.2.2.

**6.2.2 Determination**

**6.2.2.1** Introduce into the flask (4.7) about 10 ml of water, 1 ml of the potassium hydroxide solution (3.8) and 0,15 ml of the hydrogen peroxide solution (3.9). Pass oxygen (3.6) into the flask through a glass tube at a rate of 250 to 350 ml/min for 5 min to displace the air.

**6.2.2.2** Ignite the filter paper tail with a gas flame and quickly insert the stopper carrying the platinum wire and burning filter paper into the flask.

**CAUTION** – If a safety cage is not used, it is essential that the operator wears protective goggles and gloves.

**6.2.2.3** During combustion, keep the flask inverted so that the liquid covers the bottom of the stopper, and leakage of the stopper and escape of gas are avoided. When combustion is finished, turn the flask upright and gently shake

under a stream of cold water to cause rapid and complete absorption of the hydrochloric acid produced.

**CAUTION** – It is unsafe to hold the flask in the hand during this procedure and it is also dangerous to cool the flask in cold water.

**6.2.2.4** After 30 min, open the flask and transfer the contents quantitatively to a 100 ml beaker, rinsing so that the final volume is about 30 ml. Add about 1 g of sodium nitrate (3.7) and 2,5 ml of the nitric acid solution (3.2), and boil the solution for 5 min. After cooling, determine the chlorine content, by electrometric titration or by the Volhard method, with the silver nitrate solution (3.1).

**6.2.3 Blank test**

Carry out a blank test following the procedure specified in 6.2.1 and 6.2.2, but omitting the test portion.

**7 EXPRESSION OF RESULTS**

**7.1** The total chlorine content, expressed as a percentage by mass, is given by the formula

$$3,55 \times \frac{0,1 (V_1 - V_0)}{m}$$

where

*m* is the mass, in grams, of the test portion;

*V*<sub>0</sub> is the volume, in millilitres, of the silver nitrate solution (3.1) used for the blank test;

*V*<sub>1</sub> is the volume, in millilitres, of the silver nitrate solution (3.1) used for the determination.

**NOTE** – If the concentration of the standard volumetric solution used is not exactly as specified in the list of reagents, an appropriate correction should be made.

**7.2** Express the result as the arithmetic mean of two determinations which do not differ by more than ± 0,2 % (*m/m*).

**8 TEST REPORT**

The test report shall include the following information :

- a) full identification of the sample;
- b) reference to this International Standard;
- c) the test method used (A or B);
- d) the total chlorine content of the sample, according to 7.2.

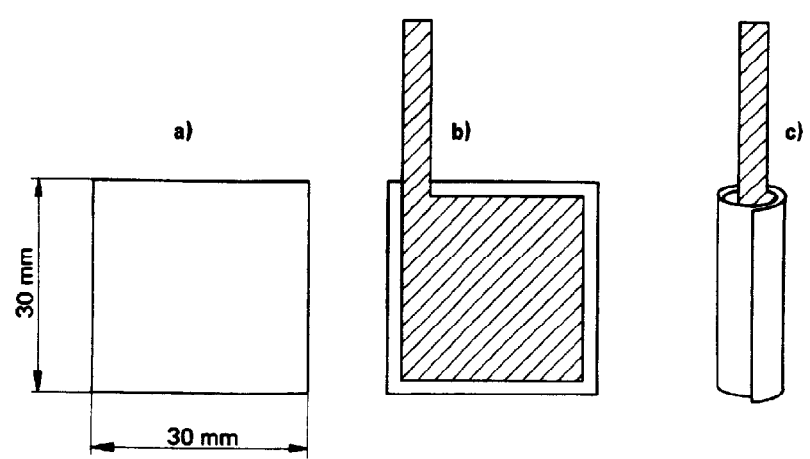

FIGURE 3 – Preparation of holder for liquid test portion

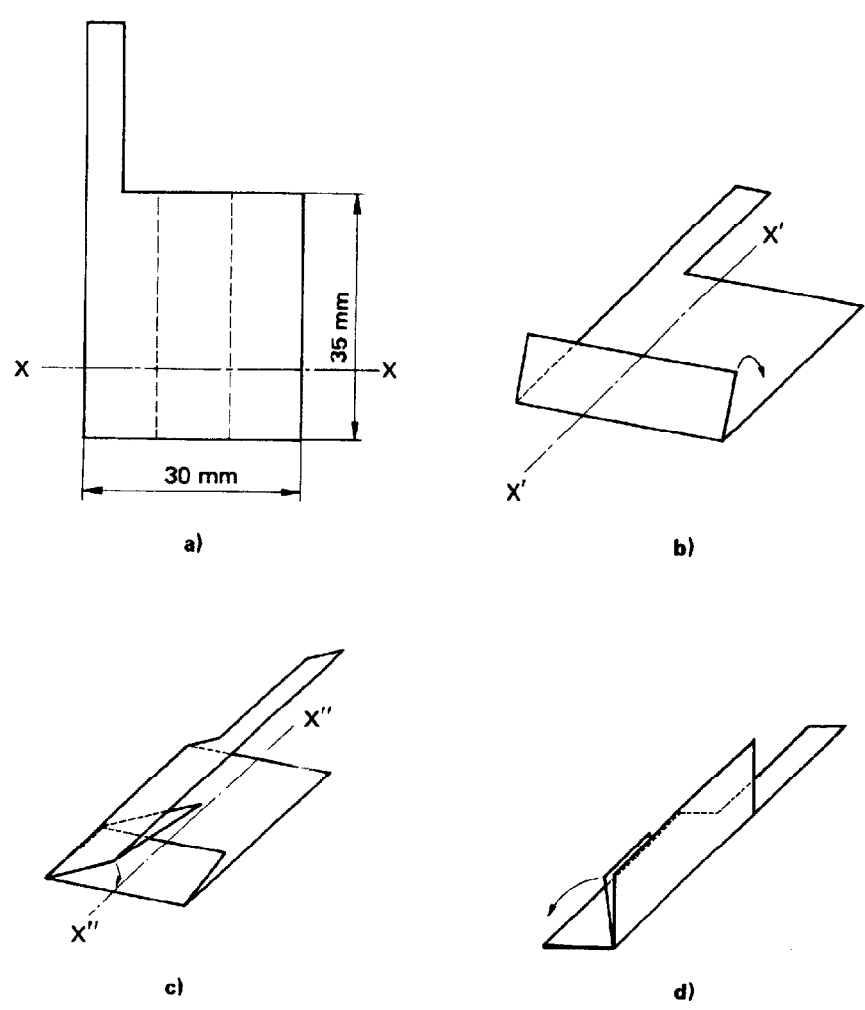

FIGURE 4 – Folding of filter paper containing solid test portion