

INTERNATIONAL STANDARD

**ISO
4608**

Third edition
1998-05-01

Plastics — Homopolymer and copolymer resins of vinyl chloride for general use — Determination of plasticizer absorption at room temperature

*Plastiques — Résines d'homopolymères et de copolymères de chlorure
de vinyle à usages généraux — Détermination de la prise de plastifiant
à température ambiante*

This material is reproduced from ISO documents under International Organization for Standardization (ISO) Copyright License number IHS/ICC/1996. Not for resale. No part of these ISO documents may be reproduced in any form, electronic retrieval system or otherwise, except as allowed in the copyright law of the country of use, or with the prior written consent of ISO (Case postale 56, 1211 Geneva 20, Switzerland, Fax +41 22 734 10 79), IHS or the ISO Licensor's members.



Reference number
ISO 4608:1998(E)

ISO 4608:1998(E)**Foreword**

ISO (the International Organization for Standardization) is a worldwide federation of national standards bodies (ISO member bodies). The work of preparing International Standards is normally carried out through ISO technical committees. Each member body interested in a subject for which a technical committee has been established has the right to be represented on that committee. International organizations, governmental and non-governmental, in liaison with ISO, also take part in the work. ISO collaborates closely with the International Electrotechnical Commission (IEC) on all matters of electrotechnical standardization.

Draft International Standards adopted by the technical committees are circulated to the member bodies for voting. Publication as an International Standard requires approval by at least 75 % of the member bodies casting a vote.

International Standard ISO 4608 was prepared by Technical Committee ISO/TC 61, *Plastics*, Subcommittee SC 9, *Thermoplastic materials*.

This third edition cancels and replaces the second edition (ISO 4608:1984), which has been technically revised.

© ISO 1998

All rights reserved. Unless otherwise specified, no part of this publication may be reproduced or utilized in any form or by any means, electronic or mechanical, including photocopying and microfilm, without permission in writing from the publisher.

International Organization for Standardization
Case postale 56 • CH-1211 Genève 20 • Switzerland
Internet central@iso.ch
X.400 c=ch; a=400net; p=iso; o=isocs; s=central

Printed in Switzerland

Plastics — Homopolymer and copolymer resins of vinyl chloride for general use — Determination of plasticizer absorption at room temperature

1 Scope

This International Standard specifies a method for determining plasticizer absorption at room temperature. It is applicable to PVC general-purpose resins and filler resins (designated "G" and "F" in ISO 1060-1:1998, *Plastics — Homopolymer and copolymer resins of vinyl chloride — Part 1: Designation system and basis for specifications*).

The object of the test is to determine the quantity of plasticizer absorbed by a resin at room temperature to give a dry mixture.

The results give a general indication of the plasticizer absorption of a resin at room temperature. They indicate the usefulness of resins for the manufacture of plasticized dry blends, particularly when taken in conjunction with the results of plasticizer absorption tests under hot conditions.

2 Normative reference

The following standard contains provisions which, through reference in this text, constitute provisions of this International Standard. At the time of publication, the edition indicated was valid. All standards are subject to revision, and parties to agreements based on this International Standard are encouraged to investigate the possibility of applying the most recent edition of the standard indicated below. Members of IEC and ISO maintain registers of currently valid International Standards.

ISO 1385-1:1977, *Phthalate esters for industrial use — Methods of test — Part 1: General*.

3 Principle

An excess of bis-(2-ethylhexyl) phthalate (DOP) is added to a specified amount of resin. The mixture is then centrifuged under defined conditions and the amount of plasticizer retained by the resin determined.

4 Apparatus and materials

Ordinary laboratory apparatus, plus the following:

- 4.1 **Balance**, capable of weighing to 0,1 mg.
- 4.2 **Burette**, for example 50 cm³, graduated at 0,1 cm³ intervals.

4.3 Centrifuge, whose rotor turns in a horizontal plane and which has an acceleration under the test conditions of $24\,500\text{ m}\cdot\text{s}^{-2}$ to $29\,500\text{ m}\cdot\text{s}^{-2}$ measured at the bottoms of the tubes, with, if necessary, a cooling system to prevent the temperature of the mixture from exceeding $30\text{ }^{\circ}\text{C}$ at the end of centrifuging for 60 min.

NOTE — It is permissible to use different centrifuging conditions, i.e. a different acceleration, a different time and smaller centrifuge tubes (see 4.4), provided that it has been verified that the results obtained are equivalent.

4.4 Centrifuge tubes, to fit the centrifuge used, each consisting either of a tube, made of glass or another material, with a conical bottom pierced by a hole of about 0,8 mm diameter (see figure 1) or of a cylindrical tube fitted at one end with a sieve plate on which a filter paper can be placed (see figure 2). The sieve plate is pierced by holes of diameter approximately 0,8 mm. The holes are arranged concentrically approximately 4 mm apart.

4.5 Sheaths, made of polyamide, polyethylene or any other suitable material, to fit the centrifuge used, with a reduction tube at the bottom to support the centrifuge tube (see figure 1 or 2).

Dimensions in millimetres

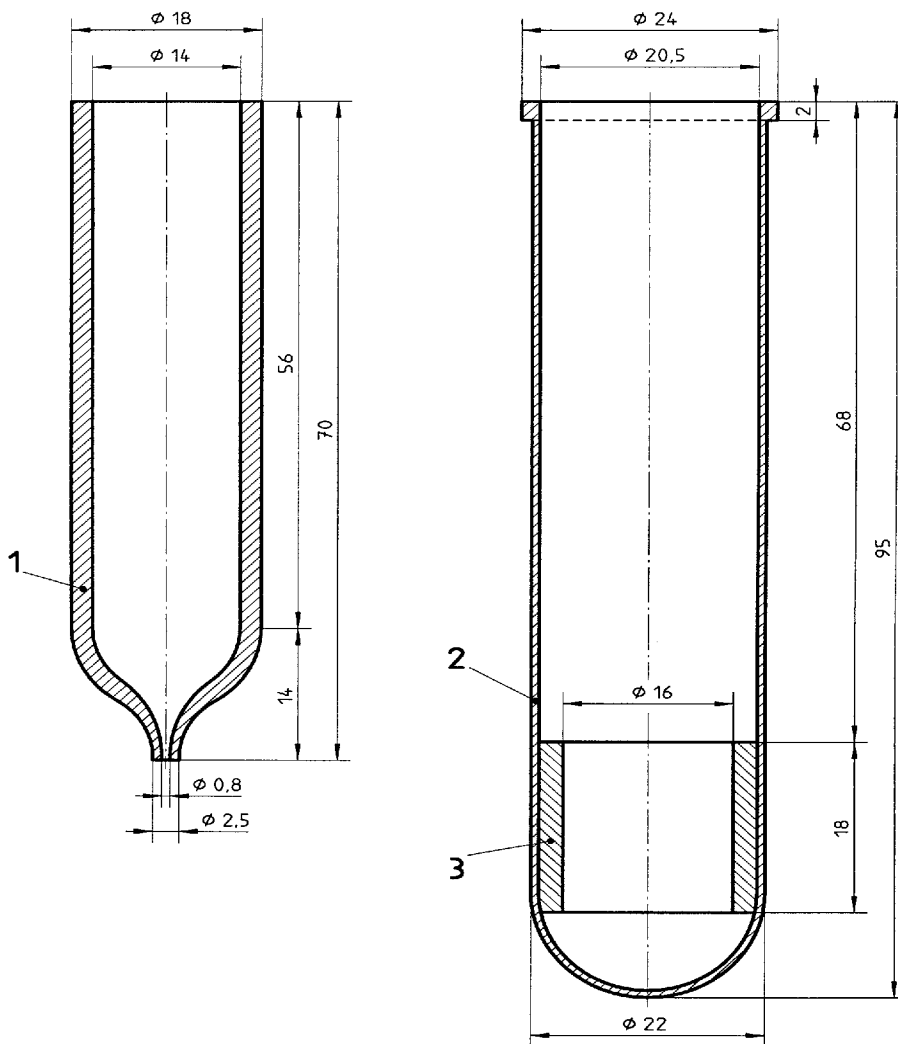

- Key**
- 1 Centrifuge tube
 - 2 Sheath
 - 3 Reduction tube

Figure 1 — Example of centrifuge tube (without sieve plate) and sheath

Dimensions in millimetres

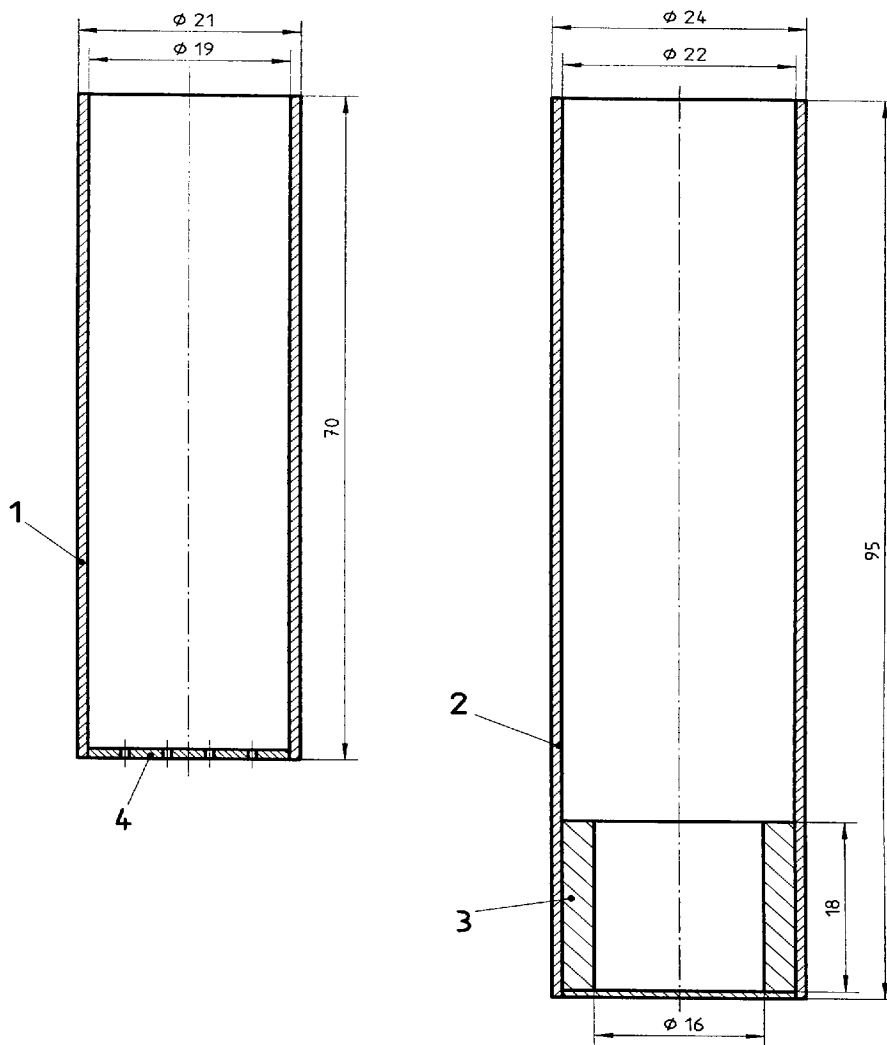

Key

- 1 Centrifuge tube
- 2 Sheath
- 3 Reduction tube
- 4 Sieve plate

Figure 2 — Example of centrifuge tube (with sieve plate) and sheath

4.6 Cotton wool, pharmaceutical quality, having a DOP absorption measured under the test conditions (see 5.1) of approximately 10 %, or, if a centrifuge tube with a sieve plate is used, **filter paper**, with a diameter is equal to the inner diameter of the centrifuge tube.

NOTE — Alternative materials to cotton wool may be used if it can be shown that they produce equivalent results, for example glass wool and PTFE-coated polyester felt.

4.7 Bis-(2-ethylhexyl) phthalate (DOP)

When tested by the methods described in ISO 1385-1 at 20 °C, the DOP plasticizer used shall have the following properties:

Density	0,982 g/cm ³ to 0,984 g/cm ³
Refractive index	1,486 to 1,487
Dynamic viscosity	77 mPa·s to 83 mPa·s

5 Procedure

5.1 Measurement of DOP absorbed by the cotton wool or filter paper

Following the procedure indicated in 5.2, carry out a blank test with a piece of cotton wool having a mass of 100 mg ± 2 mg or with a filter paper (if a centrifuge tube with a sieve plate is used), but without any resin.

Determine the amount of DOP absorbed by the cotton wool or filter paper, in grams.

5.2 Determination

Weigh a piece of cotton wool (100 mg ± 2 mg), place it in the centrifuge tube and pack it down slightly. When working with a centrifuge tube with a sieve plate, place a filter paper on the sieve plate. Weigh the tube and cotton wool or filter paper to the nearest 0,1 mg.

Weigh directly into the tube 2,000 g ± 0,001 g, to the nearest 0,1 mg, of the resin under test.

From the burette, run into the tube 4 cm³ of DOP and allow it to stand for about 10 min.

NOTE — If smaller centrifuge tubes are used (see the note to 4.3), the following smaller quantities of material may be used:

- 1 g of resin under test;
- 2 cm³ of DOP.

Put the tube into its sheath and place the whole into one of the compartments of the centrifuge rotor (the other compartments being occupied by tubes containing other resin samples, all the tubes being balanced).

Set the centrifuge to give an acceleration of 24 500 m·s⁻² to 29 500 m·s⁻² at the bottoms of the tubes for 60 min. If necessary, switch on the cooling device during centrifuging. The temperature shall not exceed 30 °C.

Take the tube from its sheath, carefully wipe it to remove any DOP on the outside and weigh it to the nearest 0,1 mg.

6 Expression of results

The room temperature plasticizer absorption, expressed as parts of DOP absorbed per 100 parts of resin (p.h.r.), is given by the formula

$$\frac{(m_3 - m_0) - m_2}{m_2 - m_1} \times 100$$

where

m_0 is the mass, in grams, of DOP absorbed by the cotton wool or filter paper in the blank test (see 5.1);

m_1 is the mass, in grams, of the centrifuge tube plus cotton wool or filter paper (see 5.2);

m_2 is the mass, in grams, of the centrifuge tube plus cotton wool or filter paper and resin sample (see 5.2);

m_3 is the mass, in grams, of the centrifuge tube plus cotton wool or filter paper, resin and DOP absorbed, after centrifuging (see 5.2).

7 Precision

Interlaboratory trials conducted on three resins in five laboratories have shown that the repeatability standard deviation s_r (within the same laboratory) and the reproducibility standard deviation s_R (between different laboratories) depend on the plasticizer absorption, as shown in table 1.

Table 1 — Precision data

	Plasticizer absorption (%)		
	approx. 5	approx. 21	approx. 40
s_r	0,25	0,37	0,42
s_R	0,43	0,60	0,72

The centrifuge tubes and sheaths used (figure 1 and 2) have only a minor influence.

8 Test report

The test report shall include the following information:

- a reference to this International Standard;
- all details necessary for identification of the sample tested;
- the centrifuging conditions (acceleration and time), if different from those specified in 5.2;
- the quantities of resin and DOP used, if different from those specified in 5.2;
- the result of the test;
- the date of the test.

ICS 83.080.20

Descriptors: plastics, vinyl resins, polyvinyl chloride, tests, determination, plasticizer absorption.

Price based on 5 pages
