

---

International Standard



4572

---

INTERNATIONAL ORGANIZATION FOR STANDARDIZATION • МЕЖДУНАРОДНАЯ ОРГАНИЗАЦИЯ ПО СТАНДАРТИЗАЦИИ • ORGANISATION INTERNATIONALE DE NORMALISATION

---

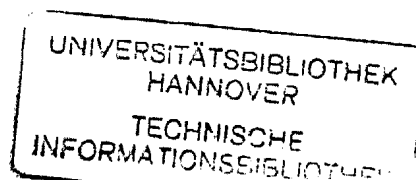

## Hydraulic fluid power — Filters — Multi-pass method for evaluating filtration performance

*Transmissions hydrauliques — Filtres — Évaluation du rendement par la méthode de filtration en circuit fermé*

First edition — 1981-04-01

---

UDC 621.648.5

Ref. No. ISO 4572-1981 (E)

**Descriptors :** hydraulic fluid power, hydraulic equipment, filters, tests, performance tests, test equipment, filtration analysis, efficiency.

Price based on 28 pages

## Foreword

ISO (the International Organization for Standardization) is a worldwide federation of national standards institutes (ISO member bodies). The work of developing International Standards is carried out through ISO technical committees. Every member body interested in a subject for which a technical committee has been set up has the right to be represented on that committee. International organizations, governmental and non-governmental, in liaison with ISO, also take part in the work.

Draft International Standards adopted by the technical committees are circulated to the member bodies for approval before their acceptance as International Standards by the ISO Council.

International Standard ISO 4572 was developed by Technical Committee ISO/TC 131, *Fluid power systems and components*, and was circulated to the member bodies in December 1978.

It has been approved by the member bodies of the following countries :

Australia	Hungary	Romania
Austria	India	Spain
Belgium	Italy	Sweden
Canada	Japan	Turkey
Chile	Korea, Rep. of	United Kingdom
Czechoslovakia	Netherlands	USA
Finland	Norway	USSR
Germany, F.R.	Poland	Yugoslavia

The member bodies of the following countries expressed disapproval of the document on technical grounds :

France  
South Africa, Rep. of

## Contents

	Page
0 Introduction .....	1
1 Scope and field of application .....	1
2 References .....	1
3 Definition .....	2
4 Graphical symbols .....	2
5 General procedure .....	2
6 Test equipment .....	2
7 Test conditions accuracy .....	3
8 Filter performance test circuit validation procedures .....	3
9 Preliminary preparation .....	4
10 Filter performance test .....	5
11 Data accuracy .....	5
12 Calculations .....	6
13 Data presentation .....	6
14 Criteria for acceptance .....	6
15 Summary of designated information .....	6
16 Justification statement .....	7
17 Test/production similarity .....	7
18 Identification statement (Reference to this International Standard) .....	7
Annex — Discussion of filtration performance, testing and test results .....	11

# Hydraulic fluid power — Filters — Multi-pass method for evaluating filtration performance

## 0 Introduction

In hydraulic fluid power systems, power is transmitted and controlled through a liquid under pressure within an enclosed circuit. The ideal filter for a hydraulic system offers infinite restriction to the passage of particulate contaminants, exhibits zero resistance to the flow of fluid and provides unlimited capacity for retained contaminant.

An actual filter cannot exhibit such phenomenal performance characteristics. Therefore, test procedures must be available to establish its degree of ideality (filter capability).

The performance characteristics of a filter are a function of the element (configuration and material) and the housing (general configuration and seal design).

In practice, a filter is subjected to a continuous flow of contaminant entrained in the hydraulic fluid until a specified terminal pressure drop (relief valve cracking pressure) results.

Both the length of operating time (prior to reaching the terminal pressure drop) and the contaminant level at any point in the system are functions of the rate of contaminant addition (i.e. rates of contaminant ingress and generation) and the capability of the filter.

Therefore, a realistic laboratory test which establishes filter capability must provide the test filter with a continuous supply of ingressed contaminant and allow the periodic monitoring of the performance characteristics of the filter.

The contamination level of the fluid immediately downstream of a filter is directly related to the contamination level of the upstream fluid. The contamination level of a fluid is given by the particle size distribution. This distribution can be accurately measured for particle sizes greater than 10  $\mu\text{m}$  using currently available automatic particle counters. However, particle size distributions associated with an operating system always exhibit higher cumulative particle counts at 10 and 20  $\mu\text{m}$  than at larger sizes. Therefore the separation characteristics of a filter can be most accurately determined statistically by using the particle counts at the lower  $\mu\text{m}$  sizes.

Experience shows that optimum discrimination and excellent repeatability are achieved using cumulative particle counts at 10  $\mu\text{m}$ .

Fluid samples must be extracted from the test system to evaluate the filter element's particulate removal characteristics. To prevent this sampling from adversely affecting the test results, a lower limit is placed upon the rated flow of filter

elements which may be tested with this procedure. Thus the current maximum flow rate is based upon the maximum gravimetric level of contaminant injection systems which have so far been qualified whilst the current maximum 10  $\mu\text{m}$  filtration ratio is based on the highest ratio for filters which have been tested in more than one laboratory. It has been determined that this procedure is currently only applicable for filter elements meeting the requirements given in clause 1.

Since it is difficult to specify, achieve and verify a cyclic flow requirement that is both realistic and consistent with the flow variations occurring in actual systems, the compromise of a steady-state condition has been used for this test to enhance the repeatability and reproducibility of results.

Additional information and verification data are provided in the annex.

## 1 Scope and field of application

This International Standard establishes a multi-pass filtration performance test with continuous contaminant injection for fine hydraulic fluid power filter elements.

It also includes a procedure for determining the contaminant capacity, particulate removal characteristics and pressure loss.

It also includes a test currently applicable to hydraulic fluid power filter elements which exhibit a 10  $\mu\text{m}$  filtration ratio of less than 75, a final reservoir gravimetric level of less than 200 mg/L and a rated flow between 4 and 600 L/min.

This International Standard provides a test procedure which yields reproducible test data for evaluating the filtration performance of a fine hydraulic power filter element.

## 2 References

ISO 1219, *Fluid power systems and components — Graphic symbols.*

ISO 2942, *Hydraulic fluid power — Filter elements — Determination of fabrication integrity.*

ISO 2944, *Fluid power systems and components — Nominal pressures.*

ISO 3722, *Hydraulic fluid power — Fluid sample containers — Qualifying and controlling cleaning methods.*

ISO 3938, *Hydraulic fluid power — Contamination analysis data — Reporting method.*<sup>1)</sup>

ISO 3968, *Hydraulic fluid power — Filter elements — Evaluation of pressure drop versus flow characteristics.*<sup>1)</sup>

ISO 4021, *Hydraulic fluid power — Particulate contamination analysis — Extraction of fluid samples from lines of an operating system.*

ISO 4402, *Hydraulic fluid power — Calibration of liquid automatic particle-count instruments — Method using Air Cleaner Fine Test Dust contaminant.*

ISO 5598, *Fluid power systems and components — Vocabulary.*<sup>1)</sup>

### 3 Definition

**multi-pass test** : A test which requires the recirculation of unaltered effluent fluid through the filter element.

For definitions of other terms used, see ISO 5598.

### 4 Graphical symbols

Graphical symbols used are in accordance with ISO 1219..

### 5 General procedure

5.1 Set up and maintain apparatus per clauses 6 and 7.

5.2 Run all tests per clauses 8, 9 and 10.

5.3 Analyze data from clauses 8, 9 and 10 per clauses 11, 12 and 14.

5.4 Present data from clauses 10 and 12 per clauses 13 and 15.

### 6 Test equipment

6.1 Use a suitable timer for measuring minutes and seconds.

6.2 Use an automatic particle counter calibrated per ISO 4402, or any ISO-approved counting method. The accuracy of this filter test procedure is dependent upon the counting method used.

6.3 Use air cleaner fine test dust or any other ISO-approved equivalent contaminant dried at 110 to 150 °C for not less than 1 h for quantities less than 200 g.

NOTE — This standard test dust has been widely used for many years and has been shown to be consistent and suitable for use in this test procedure.<sup>2)</sup>

1) At present at the stage of draft.

2) This is commercially available. Details may be obtained from the Secretariat ISO/TC 131 or from the ISO Central Secretariat.

3) 1 mm<sup>2</sup>/s = 1 cSt

6.4 Use sample bottles containing less than 1,5 particles greater than 10 µm per millilitre per bottle volume, as qualified per ISO 3722.

NOTE — This degree of cleanliness ensures a contamination contribution from the sample bottle of less than one-tenth of the minimum expected effluent level of any filter for which this test procedure is applicable.

6.5 Use petroleum base test fluid conforming to the following specifications :

#### 6.5.1 Properties of petroleum base stock

— pour point not lower than	– 59,4 °C
— flash point (min.)	93,3 °C
— acid or base number (max.)	0,10
— precipitation number	0

#### 6.5.2 Additive materials

- viscosity-temperature coefficient improver — not to exceed 10 % (m/m)
- oxidation inhibitors — not to exceed 2 % (m/m)
- triceresyl phosphate antiwear agent — in the amount of 0,5 ± 0,1 % (m/m)

Limit the free phenol content of the TCP agent to a maximum of 0,05 % (m/m).

#### 6.5.3 Properties of finished oil

— viscosity (mm <sup>2</sup> /s at 40 °C) (min.) <sup>3)</sup>	10,0
— viscosity (mm <sup>2</sup> /s at – 40 °C) (min.) <sup>3)</sup>	500
— pour point not lower than	– 59,4 °C
— flash point (min.)	93,3 °C
— precipitation number	0
— acid or base number (max.)	0,20

#### 6.5.4 Colour of finished oil

Use oil which is clear and transparent and which contains a red dye in a proportion not greater than one part of dye per 10 000 parts of oil (m/m) (used for identification only).

NOTE — The use of test fluid conforming to these specifications ensures greater reproducibility of results and is based upon current practices and other accepted filter standards. Fluid conforming to these specifications is available worldwide.

**6.6** Use a filter performance test circuit comprising a "filter test system" and a "contaminant injection system". A typical layout is shown in figure 1.

**6.6.1** The filter test system consists of :

**6.6.1.1** A reservoir constructed with a conical bottom having an included angle of not more than  $90^\circ$  and where the oil entering is diffused below the fluid surface.

NOTE — This reservoir design avoids a horizontal bottom and thus minimizes contaminant settling whilst the sub-surface diffusion reduces the entrainment of air.

**6.6.1.2** A hydraulic pump which is essentially insensitive to contaminant as the operating pressures.

WARNING — Pumps exhibiting excessive flow pulses will cause erroneous results.

**6.6.1.3** A system clean-up filter capable of providing an initial system contamination level of less than 15 particles greater than  $10\ \mu\text{m}$  per millilitre.

NOTE — This initial cleanliness ensures that the test results are not significantly influenced.

**6.6.1.4** Pressure gauges, temperature indicator and controller, and flow meter.

**6.6.1.5** Pressure taps in accordance with ISO 3968.

**6.6.1.6** A means for turbulent sampling upstream and downstream of the test filter. Sample in accordance with ISO 4021.

**6.6.1.7** Interconnecting lines which ensure that turbulent mixing conditions exist throughout the filter test system and that contaminant traps, silting areas and combinations of cyclonic separation zones and quiescent chambers are avoided.

**6.6.2** The contaminant injection system consists of :

**6.6.2.1** A reservoir constructed with a conical bottom having an included angle of not more than  $90^\circ$  and where the oil entering is diffused below the fluid surface.

NOTE — This reservoir design avoids a horizontal bottom and thus minimizes contaminant settling whilst the sub-surface diffusion reduces the entrainment of air.

**6.6.2.2** A system clean-up filter capable of providing an initial system contamination level of less than 1 000 particles greater than  $10\ \mu\text{m}$  per millilitre and a gravimetric level less than 2 percent of the calculated level at which the test is being conducted.

**6.6.2.3** A hydraulic pump (centrifugal or of another type which does not alter the contaminant particle size distribution).

**6.6.2.4** A sampling means for the extraction of a small injection flow from a point in the contaminant injection system where active circulation of fluid exists. Sample in accordance with ISO 4021.

**6.6.2.5** Interconnecting lines which ensure that turbulent mixing conditions exist throughout the contaminant injection system and that contaminant traps, silting areas and combinations of cyclonic separation zones and quiescent chambers are not present. In particular, turbulent mixing conditions must exist throughout the length of the line carrying the injection fluid.

**6.7** Use membranes and associated laboratory equipment suitable for carrying out the double membrane gravimetric method.

## 7 Test conditions accuracy

Set up and maintain equipment accuracy within the limits given in table 1.

Table 1 — Test conditions accuracy

Test condition	Unit	Maintain within ( $\pm$ ) of true value
flow	L/min	2 %
pressure	bar	2 %
temperature	$^\circ\text{C}$	$40 \pm 2\ ^\circ\text{C}$
volume	L	2 %

## 8 Filter performance test circuit validation procedures

NOTE — These validation procedures reveal the effectiveness of the filter performance test circuit in maintaining contaminant entrainment and/or preventing contaminant size modification.

### 8.1 Validation of filter test system

**8.1.1** Validate at the minimum flow that the filter test system will be operated.

NOTE — Install a filter housing or alternatively a conduit during validation.

**8.1.2** Adjust the total test system fluid volume to be numerically equal to one-fourth of the value of the minimum volume per minute.

NOTE — This is the volume to flow ratio required for the filter test procedure (see 9.3.3).

**8.1.3** Contaminate the system fluid to the calculated gravimetric level of 5 mg/L using air cleaner fine test dust.

NOTE — This contamination level is below the saturation limitations of automatic particle counters.

8.1.4 Circulate the fluid in the test system for 1 h and extract the fluid samples at 15, 30, 45 and 60 min.

8.1.5 Analyze the four fluid samples and record three cumulative particle counts at 10 and 20  $\mu\text{m}$  for each sample.

8.1.6 Accept the validation test only if :

8.1.6.1 The average of all three particle counts obtained for a given size from each sample does not deviate by more than 10 percent from the average particle counts for that size from all samples.

8.1.6.2 The average of all particle counts per millilitre at 10  $\mu\text{m}$  is not less than 600 nor more than 900.

8.1.6.3 The particle counts per millilitre at 20  $\mu\text{m}$  are not less than 100 nor more than 150.

## 8.2 Validation of contaminant injection system

8.2.1 Validate at the maximum gravimetric level and the maximum injection circuit volume to be used (see 9.2.2 and 9.2.3).

8.2.2 Add the required quantity of contaminant in slurry form to the injection system fluid and circulate for 2 h.

8.2.3 Extract fluid samples at the point where the injection fluid is discharged into the filter test system at 30, 60, 90 and 120 min and analyze each sample gravimetrically.

8.2.4 Accept the validation test only if the gravimetric level of each sample is within  $\pm 10$  percent of the average of the four samples and  $\pm 10$  percent of the known gravimetric value.

## 9 Preliminary preparation

### 9.1 Test filter assembly

9.1.1 Ensure that the test fluid cannot bypass the filter element to be evaluated.

9.1.2 Subject the test filter element to a fabrication integrity test in accordance with ISO 2942.

9.1.2.1 Disqualify the element from further testing if it fails to meet the designated test pressure.

9.1.2.2 Where applicable, allow the fluid to evaporate from the test filter element before installing it in the test filter housing.

### 9.2 Contaminant injection system

9.2.1 Using 10 mg/L as a base upstream gravimetric level, calculate the predicted test time ( $\tau'$ ) in minutes by the following equation :

$$\tau' = \frac{\text{(apparent capacity of filter element, mg)}}{\text{(10 mg/L) (test flow rate, L/min)}}$$

NOTE — A second element may be tested for capacity analysis if the value of the apparent capacity of the test element is not supplied by the filter manufacturer.

9.2.2 Calculate the minimum volume required for operation of the injection system ( $\sigma$ , litres) which is compatible with the above predicted test time ( $\tau'$ ) and a value for the injection flow of 0,5 L/min using the following equation :

$$\sigma = 1,2 (\tau', \text{ min.}) (\text{injection flow, L/min})$$

#### NOTES

1 The volume calculated above will ensure a sufficient quantity of contaminated fluid to load the test element plus 20 percent for adequate circulation throughout the test. Larger injection system volumes may be used.

2 The 0,5 L/min value of the injection flow ensures that the downstream sample flow expelled from the filter test system will not significantly influence the test results even at the lower flow rate given in clause 1. Lower injection flow rates may be used provided that the base upstream gravimetric level of 10 mg/L is maintained. An injection flow rate below 0,25 L/min is not recommended due to silting characteristics and accuracy limitation.

9.2.3 Calculate the gravimetric level ( $\gamma'$ , mg/L) of the injection system fluid using the following equation :

$$\gamma' = \frac{\text{(10 mg/L) (test flow, L/min)}}{\text{(injection flow, L/min)}}$$

9.2.4 Calculate the quantity of contaminant ( $\omega$ , g) needed for the contaminant injection system using the following equation :

$$\omega, \text{ g} = \frac{\text{(}\gamma', \text{ mg/L) (injection system volume, L)}}{1\ 000}$$

9.2.5 Adjust the injection flow rate at stabilized temperature to within  $\pm 5$  percent of the value selected in 9.2.2 and maintain throughout the test.

9.2.6 Adjust the total volume of the contaminant injection system to the value determined in 9.2.2.

9.2.7 Circulate the fluid in the contaminant injection system through its system clean-up filter until a contamination level of less than 1 000 particles greater than 10  $\mu\text{m}$  per millilitre and a gravimetric level of less than 2 percent of the value determined in 9.2.3 are attained.

9.2.8 Bypass the system clean-up filter after the required initial contamination level has been achieved (see 6.6.1.3).

9.2.9 Add in slurry form the quantity of contaminant (g) as determined in 9.2.4 to the injection system reservoir.

9.2.10 Circulate the fluid in the injection system for a minimum of 15 min to thoroughly disperse the contaminant.

### 9.3 Filter test system

9.3.1 Install the filter housing (without the test element) in the filter test system.

9.3.2 Circulate the fluid in the filter test system at the rated flow and a stabilized test temperature of  $40 \pm 2^\circ\text{C}$  and record the pressure drop at the empty filter housing.

9.3.3 Adjust the total fluid volume of the filter test system (exclusive of the system clean-up filter circuit) such that it is numerically equal to one-fourth of the value of the minimum volume flow per minute through the filter.

NOTE — Repeatable results require that the system volume be held constant. The specified 1/4 volume to flow ratio minimizes the physical size of the system reservoir as well as the quantity of test fluid required and maximizes the mixing conditions in the reservoir.

9.3.4 Circulate the fluid in the filter test system through the system clean-up filter until a contamination level of less than 15 particles greater than  $10 \mu\text{m}$  per millilitre is attained.

NOTE — The time required to achieve the contamination level is directly proportional to the particle separation capability of the clean-up filter used.

9.3.5 Select and install suitable lengths of capillary tubing upstream and downstream of the test filter such that the initial upstream sample flow is  $0,3 \pm 0,05 \text{ L/min}$  and the downstream sample flow is within 5 percent of the injection flow. Maintain uninterrupted flow from the two sampling points during the entire test.

9.3.6 Return the upstream sampling flow of the test filter directly to the reservoir when sampling is not in progress.

9.3.7 Collect the sampling flow downstream of the test filter outside the filter test system in order to assist in maintaining a constant system volume which should be kept within 15 percent of the required system volume.

## 10 Filter performance test

10.1 Install the filter element in its housing and subject the assembly to the specified test conditions (test flow with test temperature of  $40 \pm 2^\circ\text{C}$ ) and recheck fluid level.

10.2 Measure and record the clean assembly pressure drop. Calculate and record the clean element pressure drop (clean assembly pressure drop minus the housing pressure drop measured in 9.3.2). (For nominal pressures, see ISO 2944.)

10.3 Calculate the pressure drops corresponding to increases of 5, 10, 20, 40, 80 and 100 percent of the net pressure drop (arbitrary terminal pressure drop minus the clean element pressure drop).

NOTE — These percentage values provide an adequate number of data points for meaningful results.

10.4 Obtain a sample upstream of the test filter element to determine the system initial contamination level.

NOTE — Take all samples in such a manner as to minimize the aeration of the fluid sample.

10.5 Obtain a fluid sample from the contaminant injection system.

10.6 Measure and record the injection flow rate.

10.7 Initiate the filter test as follows :

10.7.1 Bypass the system clean-up filter.

10.7.2 Allow the injection flow to enter the filter test system reservoir.

10.7.3 Start the timer.

10.7.4 Start the downstream sample flow.

10.8 Record the test time (minutes) required for the pressure drop across the filter assembly to increase by 5, 10, 20, 40, 80 and 100 percent of the net pressure drop.

10.9 Extract upstream and downstream samples simultaneously at 2 min from test initiation and when the pressure drop across the filter assembly has increased by 10, 20, 40 and 80 ( $\pm 1$ ) percent of the net pressure drop.

NOTE — Use identical sample time of not more than 30 s for both upstream and downstream samples. Since the sampling procedure requires the sample volume to be within 50 to 90 percent of the sample bottle volume, more than one size sample bottle may be required.

10.10 Conclude the test by stopping the flow to the test filter.

10.11 Obtain a fluid sample from the contaminant injection system.

10.12 Measure and record the injection flow rate.

## 11 Data accuracy

Select and maintain instrumentation so that data accuracy is within the limits in table 2, unless otherwise specified.

Table 2 — Data accuracy

Quantity	Unit	Accuracy within ( $\pm$ ) of true value
injection flow rate	L/min	5 %
base upstream gravimetric level	mg/L	1 mg/L



## 12 Calculations

**12.1** Analyze the samples extracted from the filter test system by determining the number of particles greater than 10, 20, 30 and 40  $\mu\text{m}$  per millilitre with an automatic particle counter calibrated per ISO 4402, or any ISO-approved counting method.

NOTE — Care should be taken to dilute samples appropriately to avoid exceeding the saturation limit determined by the approved calibration procedure for the particular counting method used.

**12.1.1** Obtain a minimum of three particle counts for each fluid sample and calculate and record the arithmetic average for each size range counted.

**12.1.2** Accept the test only if the number of particles greater than 10  $\mu\text{m}$  per millilitre in the initial sample from the filter test system is less than 15.

**12.2** Conduct a gravimetric analysis on the two samples extracted from the contaminant injection system and on the upstream sample extracted from the filter test system at the 80 percent sample point.

NOTE — The final sample is taken at the 80 percent point because it often overlaps the 100 percent point.

**12.2.1** Record the 80 percent gravimetric value as the final system gravimetric level.

**12.2.2** Calculate the average ( $\gamma$ ) of the gravimetric levels for the two samples from the contaminant injection system.

**12.2.3** Accept the test only if the gravimetric level of each sample is within  $\pm 10$  percent of this average.

**12.3** Calculate and record the injection flow rate by averaging the measurements taken at the beginning and end of the test.

**12.3.1** Accept the test only if this value is equal to the selected value  $\pm 5$  percent.

**12.4** Calculate and record the actual base upstream gravimetric level by multiplying the average injection gravimetric level ( $\gamma$ , mg/L) by the average injection flow rate (L/min) per 12.3 and dividing by the test flow (L/min).

**12.4.1** Accept the test only if this value is equal to  $10 \pm 1$  mg/L.

**12.5** Calculate the filtration ratio as defined in the annex.

**12.5.1** Record these calculated ratios as shown in figure 3.

**12.5.2** Record the minimum filtration ratio in figure 3.

## 13 Data presentation

**13.1** Record the following minimum information for filter elements evaluated using this International Standard :

**13.1.1** Present all test and calculation results as shown in figure 3.

**13.2** Using the actual time ( $\tau$ ) required to reach the terminal pressure drop, the average gravimetric level ( $\gamma$ ) of the injection stream and the injection flow rate, calculate the filter element air cleaner fine test dust capacity ( $\alpha$ ) using the following equation :

$$\alpha, \text{ g} = \frac{(\gamma, \text{ mg/L}) (\text{injection flow rate L/min}) (\tau, \text{ min})}{1\ 000}$$

**13.2.1** Record the air-cleaner fine test dust capacity as shown in figure 3.

**13.3** Report the values of the gravimetric levels obtained in 12.2.

**13.4** Have available a record of the following minimum test data in test reports referencing this International Standard :

- a) all physical values pertaining to the test;
- b) all additional provisions or modifications pertaining to the test;
- c) record the counting method used.

## 14 Criteria for acceptance

**14.1** Compare the minimum filtration ratio ( $\beta_{10}$ ) with the designated value.

**14.2** Compare the filter element air cleaner fine test dust capacity ( $\alpha$ ) with the designated value.

**14.3** Check that there is no visual evidence of filter element damage as a result of performing this test.

## 15 Summary of designated information

The following designated information is needed when applying this International Standard to a particular application or use :

- a) fabrication integrity test pressure (see ISO 2942);
- b) filter element test flow;
- c) terminal pressure drop;
- d) the minimum acceptable filtration ratio ( $\beta_{10}$ );
- e) the minimum acceptable filter element capacity ( $\alpha$ ) for air cleaner fine test dust.

**16 Justification statement**

Justification is as set forth in the annex.

**17 Test/production similarity**

Apply the managerial controls necessary to maintain substantial similarity between test and production components or elements.

**18 Justification statement**

(Reference to this International Standard)

Use the following statement in test reports, catalogues and sales literature when electing to comply with this International Standard :

*"Method for determining filtration performance data conforms to ISO 4572, Hydraulic fluid fower – Filters – Multi-pass method for evaluating filtration performance."*

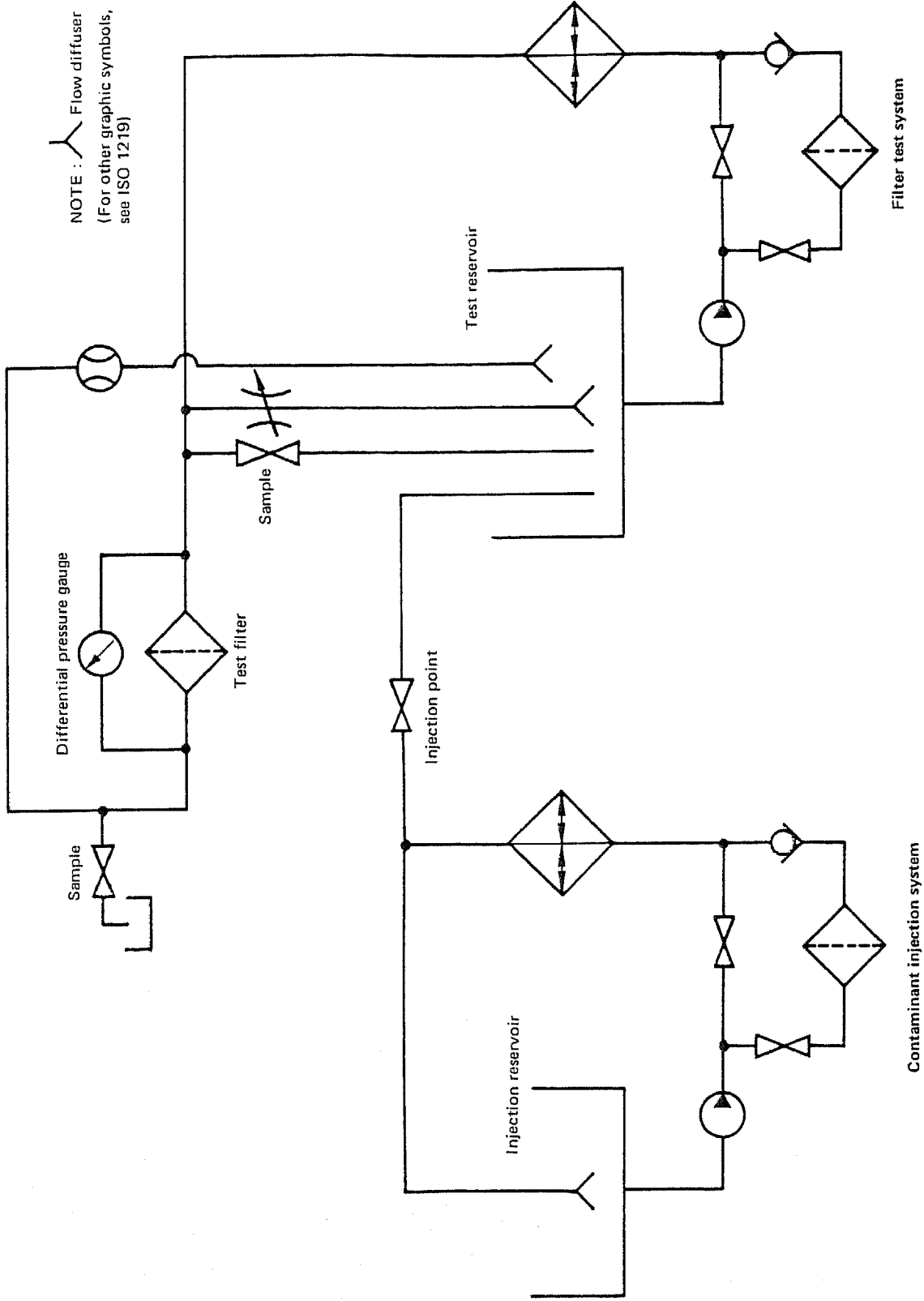

Figure 1 — Typical filter performance test circuit

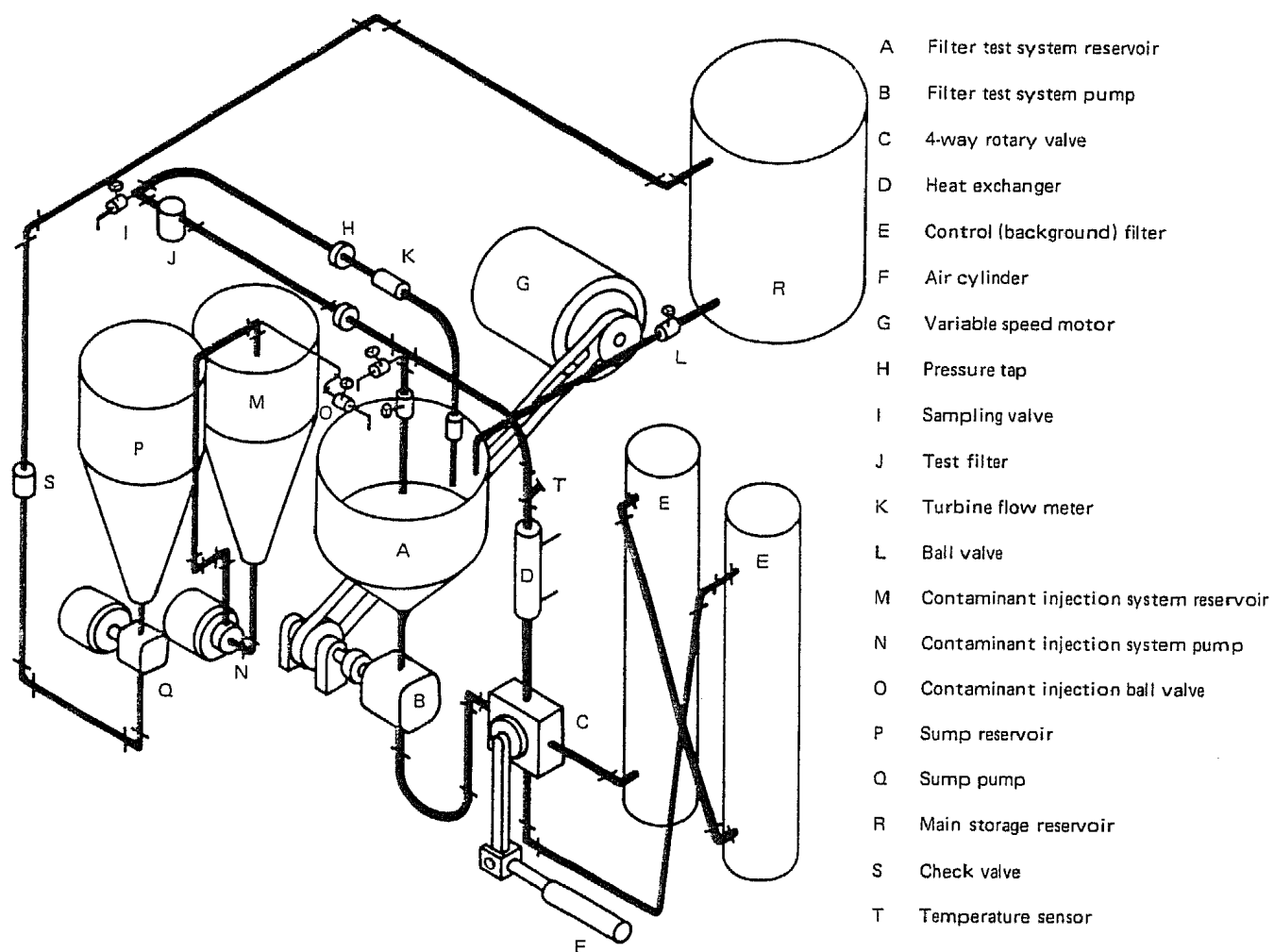

Figure 2 — A typical filter performance test system

FILTER ELEMENT MULTI-PASS TEST REPORT SHEET

Date tested : ..... Test location : .....

Filter : ..... Test flow : .....

Pressure differentials expressed in units of : ..... Terminal  $\Delta p$  : .....

Clean assembly  $\Delta p$  : ..... Housing  $\Delta p$  : ..... Clean element  $\Delta p$  : ..... Net  $\Delta p$  : .....

% Net $\Delta p$	5	10	20	40	80	100
assembly $\Delta p$						
time (min)						

Fabrication integrity verified : .....

Initial system cleanliness : ..... (Particles > 10  $\mu\text{m}$  per millilitre)

Injection fluid	Initial	Final	Average
injection flow rate (L/min)			
gravimetric level (mg/L)			

Base upstream gravimetric level : ..... mg/L

Particle distribution analysis (particles per millilitre)

Sample	Above 10 $\mu\text{m}$ (average)	Above 20 $\mu\text{m}$ (average)	Above 30 $\mu\text{m}$ (average)	Above 40 $\mu\text{m}$ (average)	Filtration ratio ( $\beta_{10}$ )
2 min	up				
	down				
10 %	up				
	down				
20 %	up				
	down				
40 %	up				
	down				
80 %	up				
	down				

Minimum  $\beta_{10}$  ratio : ..... Air cleaner fine test dust capacity : .....

Final level in reservoir : ..... mg/L

Figure 3 — Filter element multi-pass test report sheet

## Annex

### Discussion of filtration performance, testing and test results

#### Foreword

This test procedure describes a method for evaluating the performance of a hydraulic filter when it is operating under conditions which simulate as nearly as possible those of an actual hydraulic system.

This annex is intended to show to what degree actual conditions are simulated and to present the philosophy and technical aspects associated with the test procedure. The annex serves as a brief outline designed to aid understanding.

Since contamination control is necessary and a filter is the usual device for achieving such control, this annex considers both of these aspects in relation to modern hydraulic system requirements in order to formulate the necessary system filter requirements. The filtration ratio is discussed and the mathematical significance of this parameter is demonstrated by the development of the relationship which describes the filtration process.

Basic filter test concepts which have been used for evaluating filter performance are reviewed. Each technique is considered from experimental and application points of view as well as empirically and analytically. The advantages and disadvantages of each testing method are revealed and made clear.

An outline of the multi-pass filter performance test is given, followed by a discussion of the general assumptions associated with the test. To assist in the fabrication of a test facility, a clause on implementation experience is included as a part of this annex.

Finally, a summary of the extensive verification effort is presented. This summary includes the results of some 69 individual filter tests conducted at one laboratory as well as the reproducibility and repeatability data.

#### A.0 Introduction

The performance of components which are used in modern hydraulic systems is degraded by particulate contaminant which is present in the hydraulic fluid. Each component will be influenced to a different degree and in a different manner by such contaminant.

The performance of a hydraulic system is the sum total of the component performances and the manner in which they are interconnected to form the system. Any degradation in the performance of a hydraulic system is directly related to one or more component degradations.

The primary objective of any filtering device in a hydraulic system is to reduce the amount of particulate contaminant circulating in the system to a tolerable level. Reduction in the

amount of such contaminant can be expected to reduce any related degradation.

The selection of a system filter must represent a balanced choice in matching the performance characteristics of such a filtering device and the contaminant tolerance level of the system.

The performance characteristics of a filter are a function of the element design (configuration and material), the housing design (general configuration and seal design), the fluid flow conditions and the filter's previous exposure to contaminants.

The ideal filter for a hydraulic system offers infinite restriction to the passage of particulate contaminants, exhibits zero resistance to the flow of fluid, and provides unlimited capacity for retained contaminant. An actual filter cannot exhibit such phenomenal performance characteristics and, therefore, test procedures must be available to determine filter capability.

A filter performance test should be capable of providing a comparison of different filters under standard conditions approaching as closely as possible to those conditions existing in an operating hydraulic system and should permit evaluation of the contamination control balance required for the system components.

Thus an understanding of the system contamination control balance is necessary in order to formulate an acceptable filter performance test.

#### A.1 System contamination control balance

**A.1.1** This balance refers to the amount of contaminant which is present in a hydraulic system (initial plus ingressed minus removed) compared with the contaminant which can be tolerated by the system components.

**A.1.2** The contamination level of the fluid circulating in a hydraulic system is a major parameter in the prediction of life and reliability.

**A.1.3** Thus, the particulate contamination level to which the components of a hydraulic system can be exposed without reducing the performance, reliability and service life of the system below a given limit is one of the parameters of the contamination control balance.

**A.1.4** The contamination level which is attained in a hydraulic system is a function of the capability of the filter and the rate of ingress and completes the contamination control balance by comparison with the contamination level that can be tolerated by the components.

**A.1.5** The particulate contamination level of a fluid is described by the particle size distribution of the entrained contaminant.

**A.1.6** The particle size distribution of a contaminant suspended in a fluid can be measured with reasonable accuracy by an automatic particle counter, and possibly by certain visual methods or image analyzing computers. However, correlation between these different methods has not been demonstrated and reproducibility information is available only for the automatic particle counter.

**A.1.7** Thus, the contamination level of a circulating system as given by the particle size distribution is the most realistic and useful measure of the separation performance of a filter.

**A.1.8** In order to use the contamination level of a circulating system as a criterion for the separation performance of a filter, it is necessary to include the influence of system operating conditions.

## A.2 Influence of system operating conditions

**A.2.1** The functions of a filter in an operating hydraulic system subjects it to continuous exposure to contaminants entrained in the hydraulic fluid.

**A.2.2** A continuous flow of contaminant enters the fluid of an operating system from the environment through such barriers as component seals, reservoir breathers, etc., as well as that generated in components due to wear and fluid deterioration.

**A.2.3** The rate of contaminant addition to the system influences the contaminant level which the filter is continuously exposed.

**A.2.4** In an operating hydraulic system, the contaminant which is not removed by the filter will be circulated through the system and presented to the filter time again. This multi-pass action gives rise to the build-up of the smaller particle sizes (silt) observed in some hydraulic systems.

**A.2.5** It is known that the flow rate through the filter is a major factor influencing the capability of a filter to separate contaminant from the fluid passing through it and that a filter will perform differently under steady flow and pulsating flow.

**A.2.6** A realistic filter performance test must demonstrate the capability of a filter under exposure to a constant flow rate specified by the manufacturer, a continuous supply of fresh contaminant at a controlled rate and a multi-pass contaminant action.

**A.2.7** The capability of a filter given by such a test can be represented by the ratio of the particle size distribution upstream of the filter to that downstream of the filter throughout the useful life of the filter. This ratio is termed the filtration ratio.

## A.3 Filtration ratio

**A.3.1** In some cases, the "efficiency" of a filter refers to a given particle size and can be described as follows :

$$\varepsilon_m = \frac{n_u - n_d}{n_u}$$

where

$\varepsilon_m$  is the filter particle size efficiency;

$n_u$  is the number of the particles of a given size upstream of the filter;

$n_d$  is the number of particles of the same size downstream of the filter.

**A.3.2** The particle size distribution of a contaminant, however, is not measured as the number of mono-size particles. Instead, the distribution is normally measured on a cumulative basis (the number of particles greater than a given size per unit volume of fluid).

**A.3.3** Therefore, in order to use cumulative particle size distribution data in the particle size efficiency equation given in A.3.1, the number of particles in a selected size increment must be found by subtraction, and this number must then "represent" the concentration of the desired mono-size particles within the size increment.

**A.3.4** To make use of such particle size efficiency information in contamination control balance requires, among other things, a considerable amount of unnecessary approximation and calculation.

**A.3.5** Hence, a more useful and less cumbersome method of evaluating the particle separation capability of a filter is needed.

**A.3.6** Thus, any proposed filter evaluation method should use directly the cumulative particle size distribution data and should represent the lowest performance capability of the filter throughout its useful life.

**A.3.7** A term which uses these cumulative particle size distributions and which can be used to determine separation performance over the useful life of a filter is called the cumulative efficiency. This term is expressed as follows :

$$\varepsilon_c = \frac{N_u - N_d}{N_u}$$

where

$\varepsilon_c$  is the filter cumulative efficiency;

$N_u$  is the number of particles greater than a given size per unit volume of fluid upstream of the filter;

$N_d$  is the number of particles greater than the same size per unit volume of fluid downstream of the filter;

**A.3.8** Since the cumulative efficiency could be confused with the particle size efficiency of A.3.1, it is desirable to define a more explicit term. The filtration (Beta) ratio ( $\beta_\mu$ ) is such a term and is derived from the cumulative efficiency equation of A.3.7 as follows :

$$\varepsilon_c = 1 - \frac{N_d}{N_u} = 1 - \frac{1}{\beta_\mu}$$

**A.3.9** Therefore the filtration ratio  $\beta_\mu$  is defined as : the ratio of the number of particles greater than a given size ( $\mu$ ) in the influent fluid to the number of particles greater than the same size ( $\mu$ ) in the effluent fluid. The ratio can be stated by the following equation :

$$\beta_\mu = \frac{N_u}{N_d}$$

**A.3.10** The relationship between the contamination level in a realistic test system and the Beta ratio of the filter can be determined by a contaminant material (matter) balance.

#### A.4 Contaminant material (matter) balance

**A.4.1** Consider the system as illustrated below

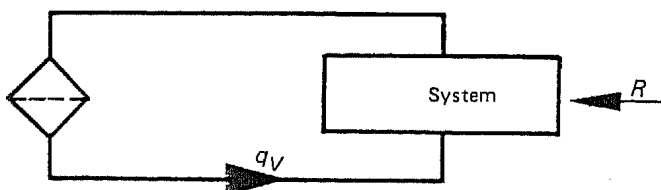

where

$R$  is the rate of contaminant addition in number of particles greater than a given size ( $\mu\text{m}$ ) per unit time;

$q_v$  is the volume flow rate.

**A.4.2** Contaminant entrained in the fluid of such a system can be accounted for in the following manner (in this case, the filter is used as a reference) :

$$\begin{aligned} &\text{Number of particles downstream} > n \mu\text{m} \\ &= \text{Number of particles initial} > n \mu\text{m} \\ &\quad + \text{Number of particles added} > n \mu\text{m} \\ &\quad - \text{Number of particles removed} > m \mu\text{m} \end{aligned}$$

NOTE — There are two major sources which contribute to the "Number of particles  $> n \mu\text{m}$  added" term of this expression. One source is the environment in which the system is operating, and the other, the wear particles originating from the components themselves. Contaminant entering a hydraulic system from the environment is called ingressed contaminant and that which originates from the components is called generated contaminant. Ingressed contaminant is generally considered to be the major source in most hydraulic systems.

**A.4.3** The word equation of A.4.2 can be written mathematically as follows :

$$(N_d) V = (N_i) V + \int R dt - \int (N_u - N_d) q_v dt$$

where

$V$  is the circulating volume;

$N_i$  is the initial number of particles greater than a given size ( $\mu\text{m}$ ) per unit volume of fluid in the system.

**A.4.4** Using the Beta ratio relationship given in A.3.9 and differentiating the equation in A.4.3 produces an expression for the contamination level downstream of the filter. This expression is derived as follows :

$$N_u = \beta_\mu N_d$$

$$N_d = N_i + \int \frac{R}{V} dt - \int (\beta_\mu N_d - N_d) \frac{q_v}{V} dt$$

$$\frac{d(N_d)}{dt} = \frac{R}{V} - (\beta_\mu - 1) \frac{q_v}{V} N_d$$

$$\frac{d(N_d)}{dt} + (\beta_\mu - 1) \frac{q_v}{V} N_d = \frac{R}{V}$$

**A.4.5** It should be noted from A.4.4 that a Beta ratio equal to one means that the filter is incapable of removing any discernible number of particles of a given size ( $\mu\text{m}$ ) or less from the fluid.

**A.4.6** Such mathematical analysis as indicated by the equations in A.4.4 is fundamental for any description of the contamination level of a real operating system.

#### A.5 Philosophical requirements for filter evaluation

**A.5.1** The preceding clauses of this annex have discussed the requirements, assumptions and basic concepts which must be included or considered in any acceptable test procedure intended for hydraulic filter evaluation. This clause will summarize these points.

**A.5.2** A filter performance test should be capable of providing a comparison of different filters under standardized conditions approaching as closely as possible the actual conditions existing in an operating hydraulic system and should permit evaluation of the contamination control balance required for the system components.

**A.5.3** The contamination level as given by the cumulative particle size distribution present in a circulating system as a result of the filter action is the most realistic and useful measure of a filter's separation performance.



**A.5.4** Thus, a filter evaluation expressed in terms of a contamination level capability which is compatible with the control balance concept will be applicable and useful to the fluid power industry in general.

**A.5.5** In order for any filter evaluation method to be realistic, the filter must be subjected to those critical conditions which will be encountered in an operating hydraulic system.

**A.5.6** Therefore, a realistic filter performance test must demonstrate the capability of a filter when exposed to a constant flow rate as specified by the manufacturer, a continuous supply of fresh contaminant at a controlled rate and a contaminant multi-pass action.

**A.5.7** In order to make practical use of the information from a filter performance test in predicting the contamination level of a real operating system, such a test must provide the necessary information for the equation describing the contamination level.

## **A.6 Basic filter test concepts**

### **A.6.1 Contaminant exposure**

**A.6.1.1** All filter tests employ one or two types of contaminant exposure concepts or techniques. One is termed "single-pass" because an auxiliary filter or some other means is used to remove the contaminant which escapes or penetrates the test filter. The second technique is called "multi-pass" because any contaminant which escapes the test filter is allowed to recirculate unaltered and unrestrained through the closed test loop and is reexposed to the filter many times.

**A.6.1.2** In addition, both of these contaminant exposure concepts can be further classified by the manner in which the contaminant is presented to the test filter. The filter can either be subjected to a relatively large amount of contaminant over discrete time periods (batch injections) or can be subjected to a much smaller amount on a continuous basis (continuous injection).

**A.6.1.3** Although the results of a single-pass test which uses either batch or continuous injection is sufficient to compare the capability of one filter relative to another, it is very difficult to interpret such information in terms of the contamination control balance for a given fluid power system.

**A.6.1.4** Also, the results of any single-pass test cannot as effectively reveal the inability of a filter to remove small particles and prevent their build-up as can the results using the multi-pass concept. The control of small particles is becoming of major importance in many hydraulic systems.

**A.6.1.5** The multi-pass test employing batch injection is characterized by the classical "clean-up" curve, which exhibits an exponential decay; which is initiated by a single, large, contaminant injection followed by filtration and a normal contaminant intermixing process. This technique disguises the true per-

formance of a filter due to the influence of the ever decreasing contamination level. The results of this test cannot adequately discriminate between filters nor reveal the inability of a filter to remove small particles.

**A.6.1.6** When an operating hydraulic system is considered, a multi-pass test with continuous injection is the contaminant exposure concept which most closely simulates the contaminant environment of a filter in such a system.

**A.6.1.7** Furthermore, the results of a continuous-injection multi-pass test will reveal any "build-up" of small particles allowed by the test filter.

**A.6.1.8** Thus, a realistic filter test must incorporate the continuous-injection multi-pass contaminant exposure concept.

### **A.6.2 Fluid exposure**

**A.6.2.1** The second basic concept of filter testing is concerned with fluid exposure where all tests can be classified as either "blow-down" or continuous circulation.

**A.6.2.2** In a blow-down or on "one-shot" type test, the contaminated fluid is prepared and contained in a large tank. During the test, this fluid is released and forced to pass through the test filter until the tank is either empty or the filter "blocked". If additional test data are desired, the tank must be refilled and the process of blow-down repeated.

**A.6.2.3** The blow-down test is capable of providing certain information associated with filter design parameters and can be used to compare filters; however, it does not simulate a realistic fluid power system condition nor can the results be interpreted in terms of actual system requirements.

**A.6.2.4** Since hydraulic systems contain a continuously flowing fluid and this flow is a parameter affecting the capability of a filter, a fluid exposure concept for a filter test other than a continuous flow type would not closely simulate the conditions of a hydraulic system.

### **A.6.3 Separation performance evaluation**

**A.6.3.1** The third basic concept of filter testing is the separation performance evaluation.

**A.6.3.2** It is recognized among contamination control specialists that the concentration of contaminant entrained the fluid of the test system after being subjected to the action of the test filter is a reliable and major parameter for filter performance evaluation.

**A.6.3.3** There are two ways in which this concentration can be evaluated. One technique measures the weight of contaminant per unit volume of the system fluid (gravimetric analysis), while the second method determines the cumulative particle size distribution.

**A.6.3.4** While gravimetric methods reflect cumulative particle concentrations, such methods do not permit precise definition of the fluid contamination level. On the other hand, particle counting limitations at small particle sizes have prevented complete definition on a cumulative particle size basis.

**A.6.3.5** By combining these two methods (gravimetric and particle counting), a more comprehensive technique is achieved for evaluating the separation performance capability of a filter.

## **A.7 Outline of multi-pass filter testing**

(See figures 4, 5, 6 and 7 for procedural diagrams.)

**A.7.1** The test filter element is subjected to the fabrication integrity test (see ISO 2942) to verify it is correctly fabricated and undamaged.

**A.7.2** The test circuit employs the continuous-injection multi-pass contaminant exposure concept.

**A.7.3** A continuous flow of fluid at a specified magnitude is maintained throughout the test period. In order to allow effective interpretation of the test data, it is necessary to maintain a constant fluid volume in the filter test system during the test.

**A.7.4** Prior to any test, the test facility (both injection system and filter test loop) must be certified as to its capability to maintain contaminant in suspension.

**A.7.5** The test element is subjected to a constant circulating flow with continuous contaminant injection until the pressure differential across the test element has increased by a given amount.

**A.7.6** Sample containers are prepared and certified in accordance with ISO 3722.

**A.7.7** Samples are extracted upstream and downstream of the test filter at given values of pressure differential over the duration of the test in accordance with ISO 4021, or any ISO-approved sampling procedure.

**A.7.8** The samples are analyzed by determining the cumulative particle size distribution. Since automatic particle counting (when calibrated in accordance with ISO 4402) has only been verified for 10  $\mu\text{m}$  and above, and since no other calibration procedures or verification evidence have been published, this cumulative particle size distribution analysis is to be limited to 10  $\mu\text{m}$  and above.

**A.7.9** The gravimetric level of the final upstream sample is measured to provide an additional evaluation of the capability of the test filter.

**A.7.10** All fundamental data derived from this test procedure are recorded on an appropriate test report sheet. Such a record permits the use of many analytical interpretative techniques which are valuable to various segments of the fluid power industry as well as allowing for future interpretation methods yet to be formulated.

**A.7.11** The test report sheet provides sufficient information to evaluate the characteristics of a filter element for three basic parameters :

a) Pressure loss :

All combinations of differential pressures for the filter element and housing.

b) Contaminant capacity :

Air cleaner fine test dust capacity using the standard contaminant specified.

c) Particle separation capability :

Filtration ratio for particle sizes greater than 10  $\mu\text{m}$  and final gravimetric level for particle sizes less than 10  $\mu\text{m}$ .

Filter performance test circuit (8.1)

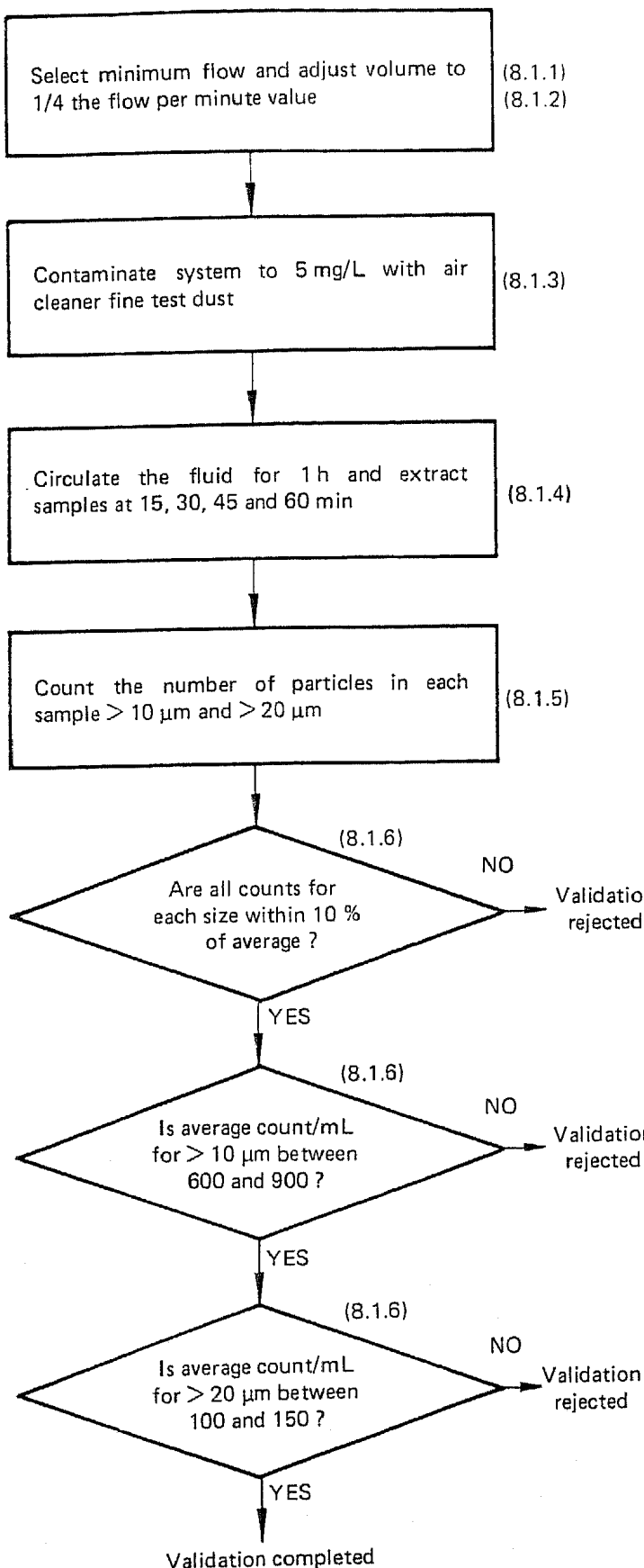

Contaminant injection system (8.2)

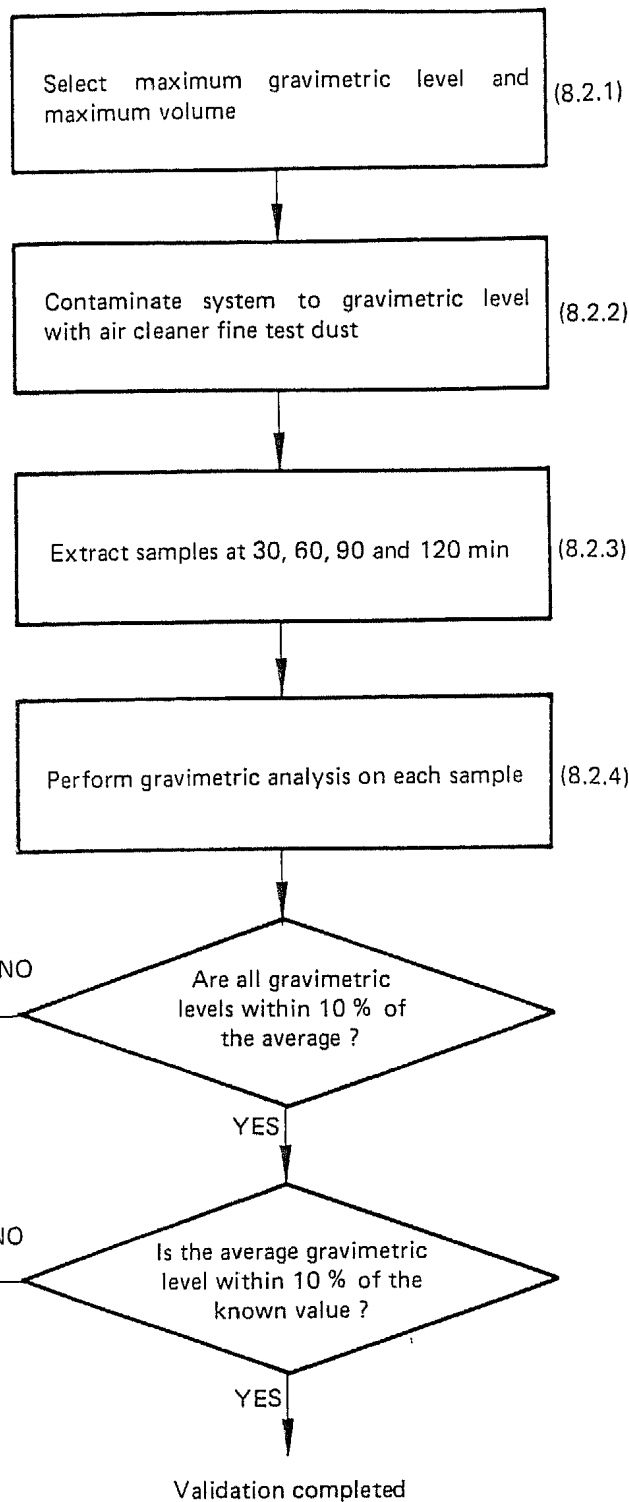

NOTE — Refer to the numbers in the main part of this International Standard for detailed information.

Figure 4 — Procedural diagram for validation

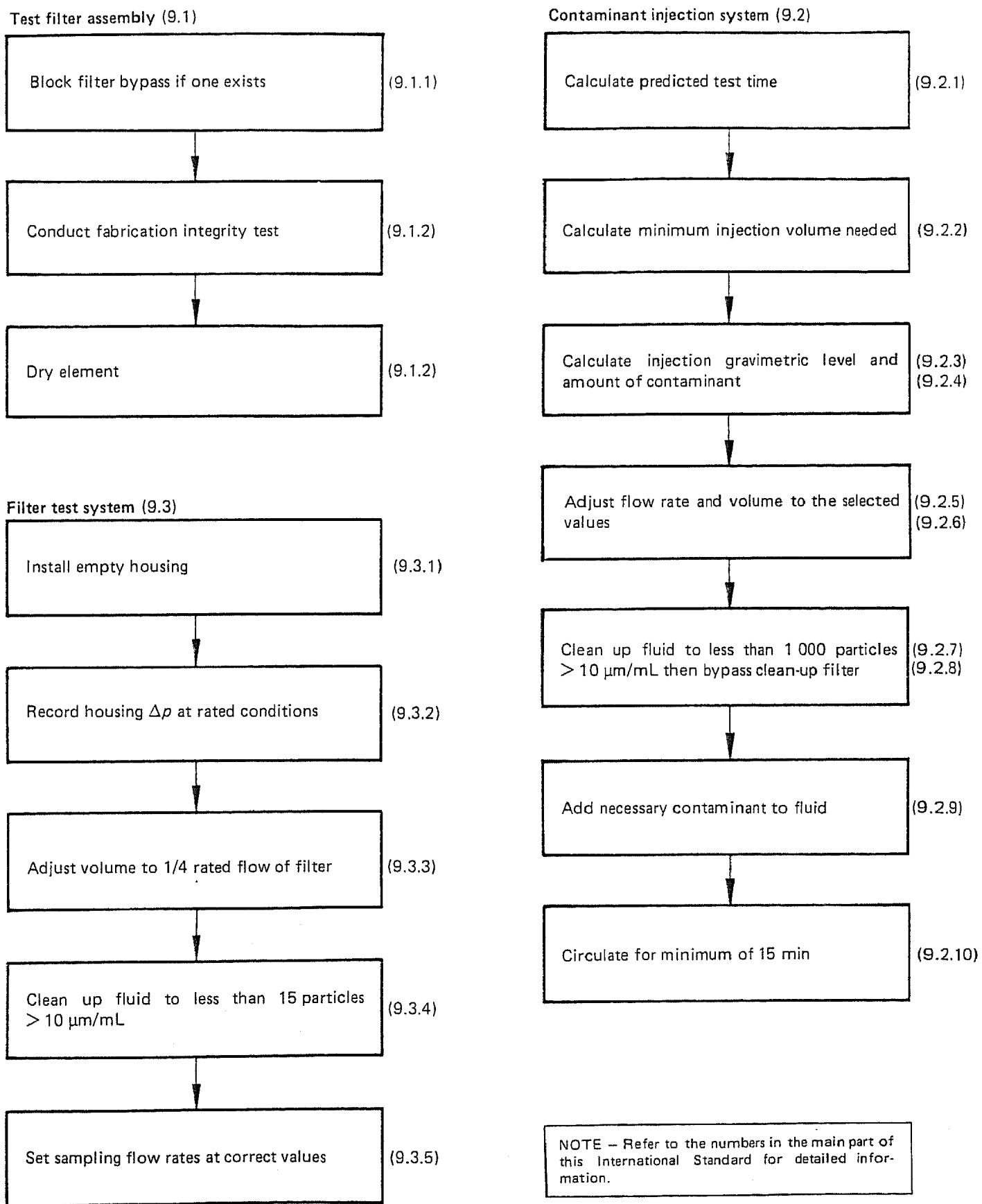

Figure 5 – Procedural diagram for preliminary preparation

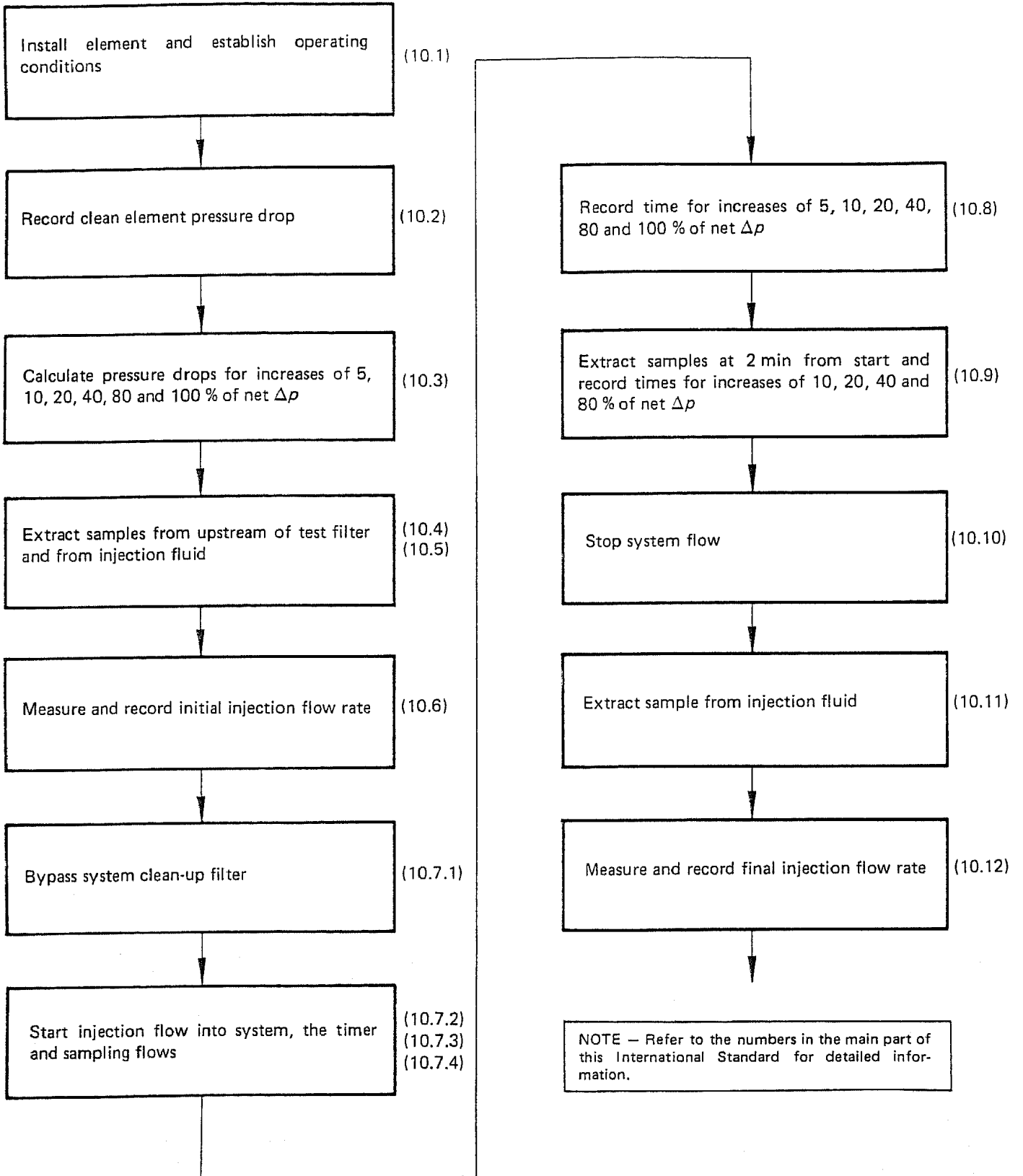

Figure 6 — Procedural diagram for filter performance test

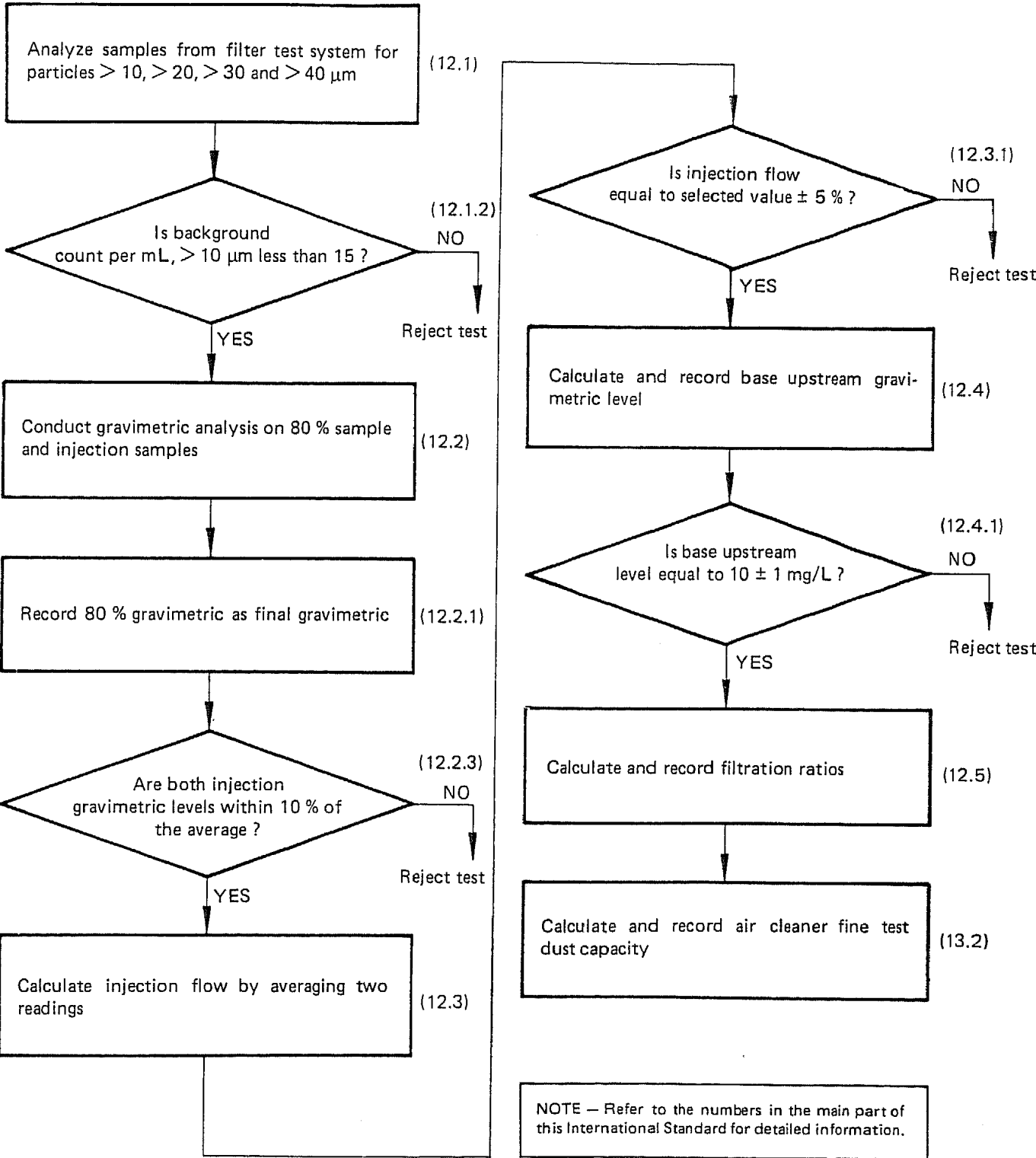

Figure 7 — Procedural diagram for data analysis and presentation

## A.8 General assumptions and explanations

**A.8.1** Since the test procedure requires that a highly contaminated slurry be continuously added to the filter test system, the same amount of fluid must be removed from the test system to prevent an increase in the total volume of the system.

**A.8.2** Filters exhibit different air cleaner fine test dust capacities and if a means is not provided to regulate the volume of the test system, then this volume would vary with the air cleaner fine test dust capacity of the filter.

**A.8.3** Therefore, the contamination level of the test system (which would be influenced by the test system volume as well as the separation performance of the test filter) would be erroneously interpreted.

**A.8.4** To regulate the volume of the test system, set the downstream sample flow to equal the injection flow and collect it outside the test system.

**A.8.5** Removing this sample flow from the test system introduces a limit to the minimum flow rate at which multi-pass action can be carried out and introduces a small error in the air cleaner fine test dust capacity rating.

**A.8.6** As the fluid downstream of the filter is the cleanest fluid in the system, the removal of fluid at this point will introduce the smallest error.

**A.8.7** The restriction of this test procedure to those filters which exhibit a filtration ratio of less than 75 was incorporated because this is the maximum filtration ratio included in the reproducibility data.

**A.8.8** If the concentration of contaminant in a fluid sample is too great, it is necessary to dilute the sample in order to reduce this concentration before attempting to obtain a particle size distribution. The greater the dilution that has to be carried out, the more chances there are of introducing errors.

**A.8.9** Thus, a filter which allows the contamination level of the test system to exceed 200 mg/L is excluded from this test procedure to prevent the possibility of large errors due to dilution.

**A.8.10** Flow rate restrictions which are included in the test procedure ensure sufficient multi-pass action at the lower flow rates and illustrate the lack of experience and capabilities at higher flow rates.

## A.9 Implementation experience

**A.9.1** Fabrication of test facilities to perform this multi-pass filter performance test has given some valuable experience. The object of this clause is to describe some of the experience gained.

**A.9.2** Pumps which produce large flow fluctuations at steady state pumping conditions should be avoided. Such pumps subject the test filter to a highly pulsating flow stream which can produce quite different results from those obtained under a more steady flow.

**A.9.3** Sampling is critical to this test procedure. Samples which are not representative of the fluid in the test system will produce error. It has been found that samples extracted under turbulent dynamic conditions are the most representative. The sampling procedure in ISO 4021 outlines a method which includes these conditions.

**A.9.4** The containers used for the fluid samples extracted during the test should be cleaned to prevent the introduction of additional contaminant. It has been found that a container contaminant background which is at least two decades below the contaminant level of the fluid placed in it is satisfactory. The procedure described in ISO 3722 will allow verification of the container background.

**A.9.5** To ensure that the contaminant which is placed in the system remains in circulation unless removed by the test filter, adequate turbulence in the system should be provided. Since there are no long, straight runs of tubing in such a test system, the relationship between Reynolds Number and fully developed fluid flow conditions does not hold. Therefore, a verification procedure is included in this test method to ensure that adequate turbulence does exist in the test system.

**A.9.6** To further enhance turbulent mixing in the test system reservoirs, a flow diffuser should be used at the termination of the return line. Typical diffuser designs are shown in figure 8.

**A.9.7** In order to be certain that the results of any filter test are representative of the performance exhibited by the medium of the filter, it is necessary to avoid any possible bypassing of the fluid around the medium. Shipping damage or fabrication defects can produce paths by which the fluid can bypass the filter medium. Such paths can be detected by a fabrication integrity test conducted in accordance with ISO 2942.

**A.9.8** Experience has shown that particle size analysis should be approached cautiously. In the past, several different dimensions have been used to designate the size of a particle (such as longest dimension, shortest dimension etc.). Also, automatic particle counters have introduced conversions from some other measurement parameter to a size dimension. For example, some automatic particle counters measure the projected area of a particle. This measurement must be and can be converted to a size dimension such as a longest dimension. This conversion is the primary purpose of the automatic particle counter calibration procedure given in ISO 3938.

**A.9.9** To date, only verification data between automatic particle counter results for particles greater than 10  $\mu\text{m}$  have been reported. Such data are not available for other counting techniques nor for particle sizes less than 10  $\mu\text{m}$ . Therefore, these verification data are used to establish the state of the art in particle size analysis.

## A.10 Summary of verification effort

**A.10.1** In order that any test procedure be given serious consideration as an International Standard, the results of a verification programme are requisite.

**A.10.2** Such a programme should demonstrate the applicability of the test results, the ease with which the test can be conducted, and the clarity of the procedural instructions. In addition, a verification effort should eliminate any ambiguous or impractical aspects associated with the test procedure.

**A.10.3** In all test procedure verification programmes, the question of accuracy and precision is important. Since knowledge of the true value of all of the test parameters is required to determine accuracy, such an appraisal is difficult and argumentative, if not impossible. Therefore, the precision of the test results is of paramount importance.

**A.10.4** The precision of a test procedure can be determined from repeatability and reproducibility data.

**A.10.5** Also, a successful verification programme must show that the criterion derived from the test results can be utilized to discriminate between the items being tested.

**A.10.6** The Beta ratio determined as part of this test procedure is influenced by the sampling techniques used, the contaminant background of the sample containers, and the capability of the particle counting method employed.

**A.10.7** An international survey has been conducted to determine particle counting capability worldwide. Based upon the results of this survey and the influence of sample container cleanliness, the expected variation in the filtration ratio can be predicted as shown in figure 9.

**A.10.8** To verify repeatability and reproducibility, several tests were conducted, both within a laboratory and between laboratories. Five laboratories participated in establishing the reproducibility which could be obtained. Figure 10 shows the results associated with the filtration ratio, while figure 11 demonstrates the variations in air cleaner fine test dust capacity.

**A.10.9** The discriminatory characteristics of this test procedure are indicated by the results of tests conducted at laboratories on a broad spectrum of filters. The results of these tests are listed in table 3 and are summarized in figure 12. It should be noted that figure 12 can also be used as a procedural control chart. Upstream and downstream particle counts falling outside the indicated range for a given filtration ratio should be considered invalid for a 10 mg/L base.



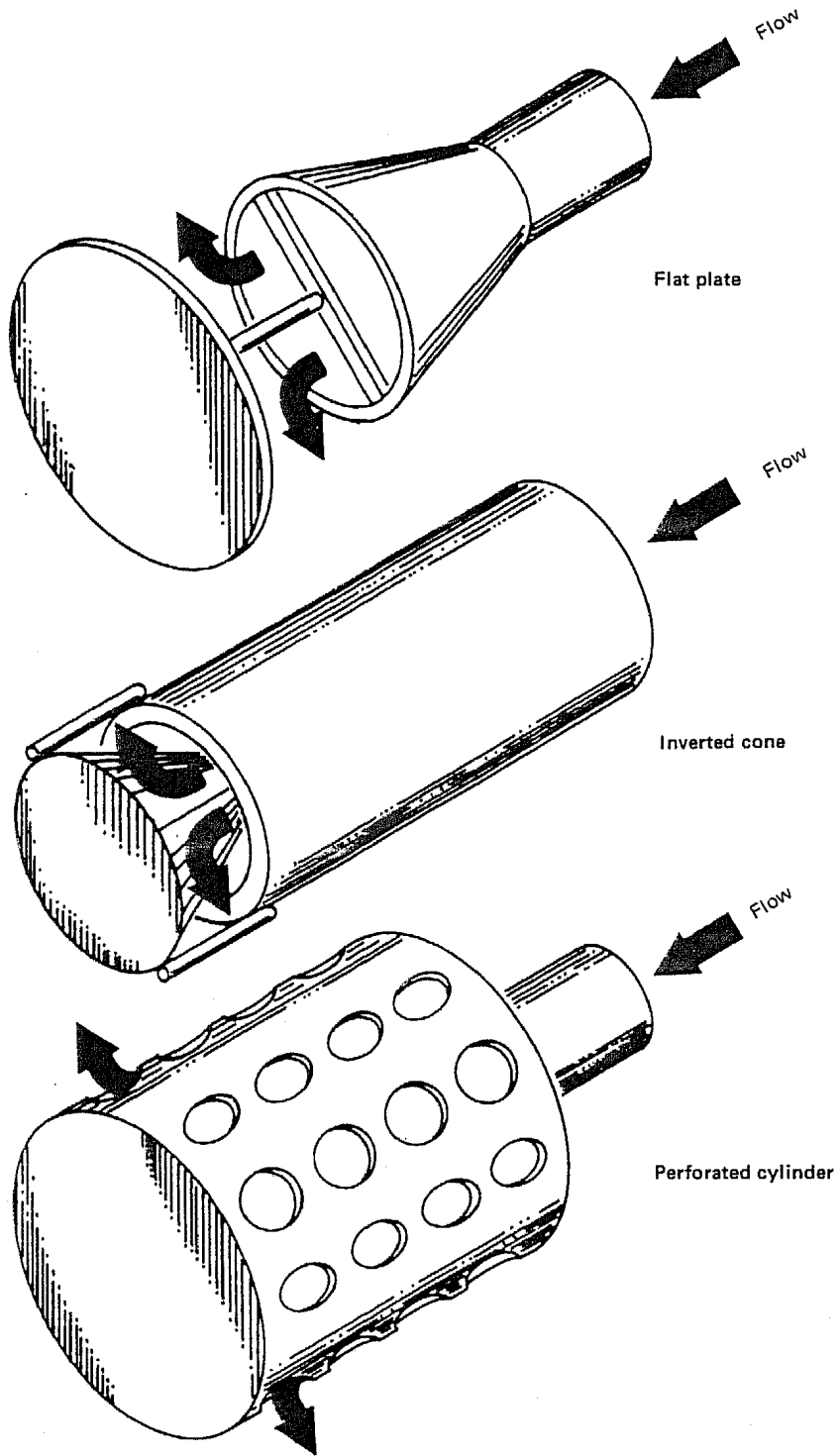
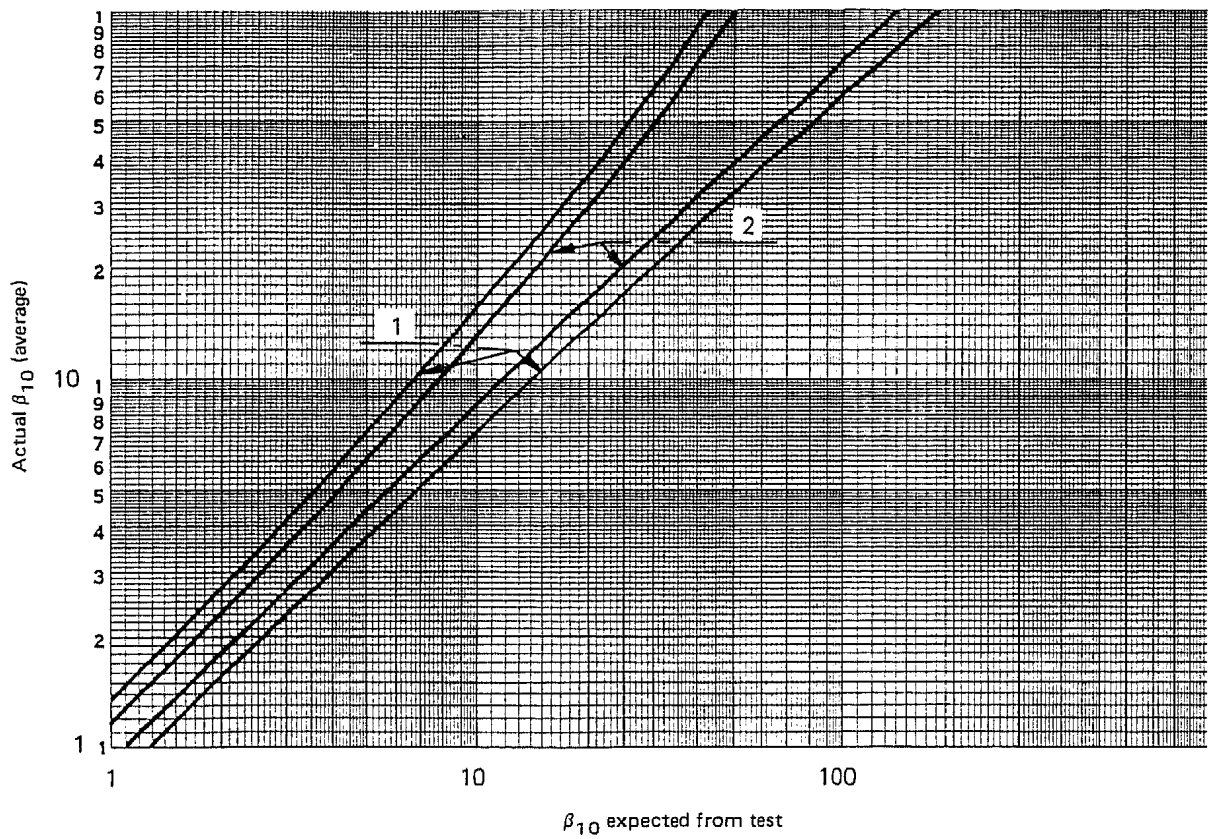

Figure 8 — Typical diffuser designs



- 1 : Maximum range between laboratories
- 2 : Maximum range within a laboratory

Figure 9 — Expected range in filtration ratio due to test (not element) variations

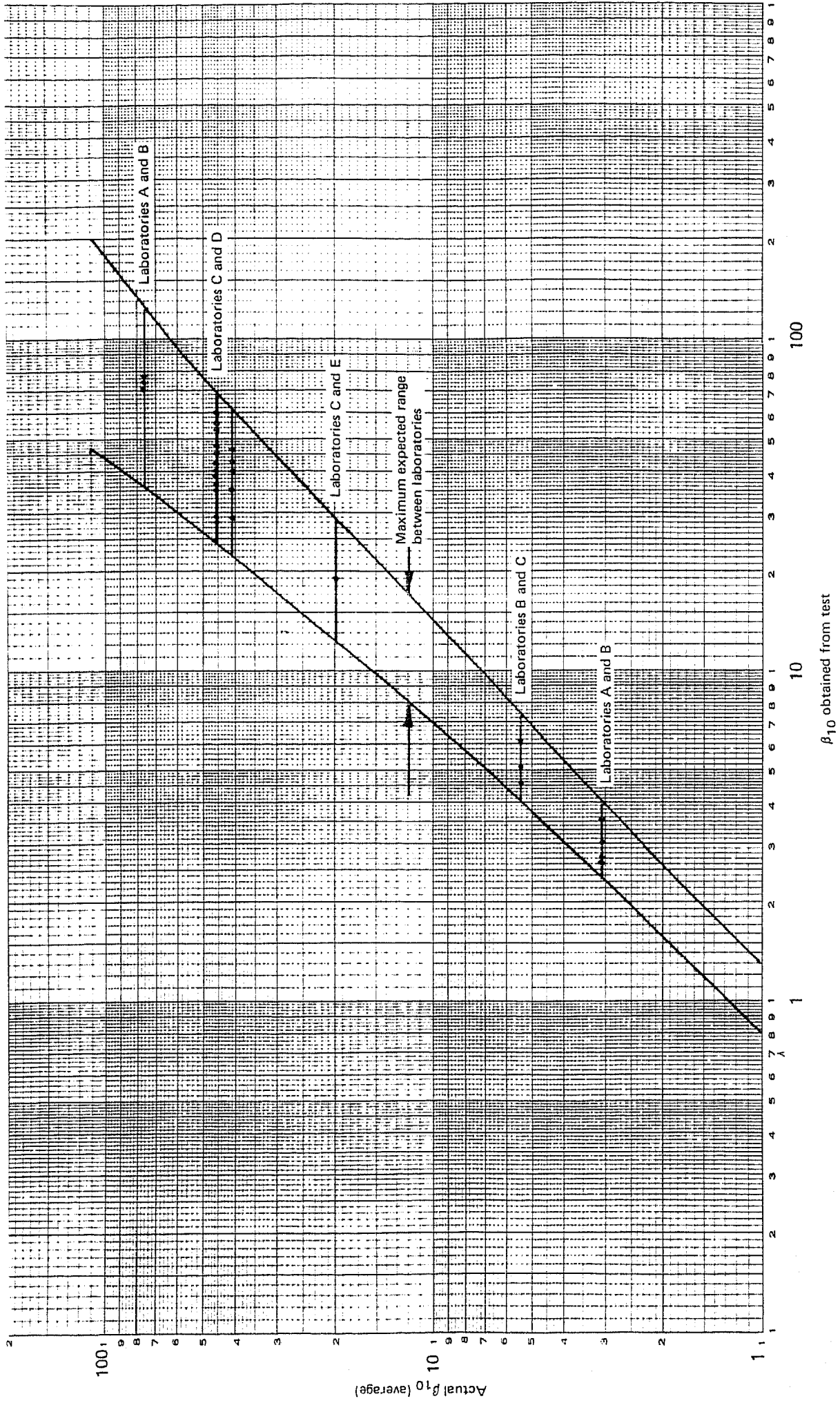

Figure 10 — Summary and evaluation of filtration ratio reproducibility

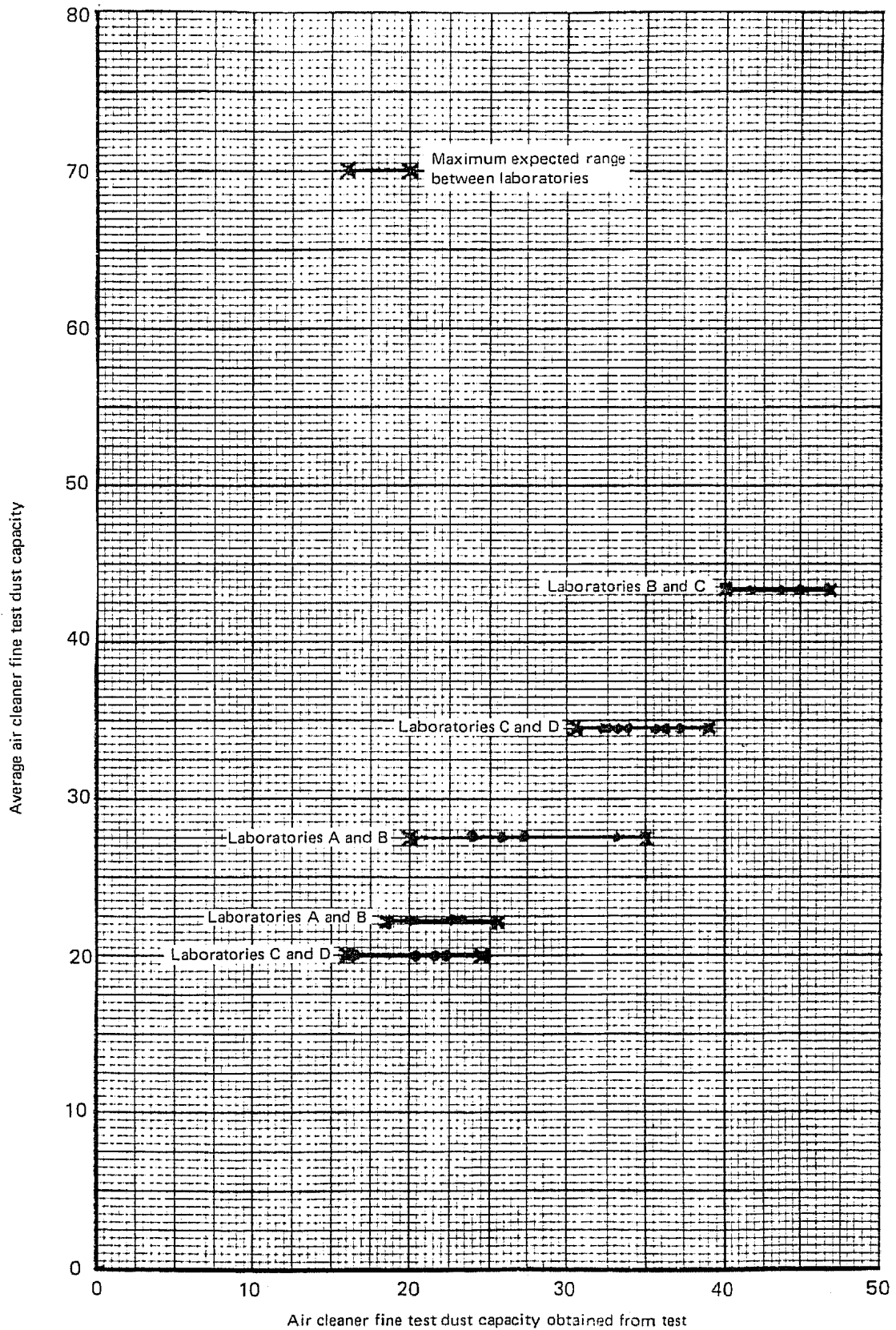

Figure 11 — Summary and evaluation of air cleaner fine test dust capacity reproducibility

Table 3 — Compilation of filter discrimination data

Filter No.	Air cleaner fine test dust capacity grams	Downstream particle size distribution				Lowest Beta ratio	Final gravimetric mg/L
		Number > 10 µm per mL	Number > 20 µm per mL	Number > 30 µm per mL	Number > 40 µm per mL		
1	56,00	1 238,0	34,70	1,90	0,25	2,31	*
2	13,30	1 666,0	2,70	0,40	0,14	1,71	*
3	7,40	56,0	8,20	2,90	0,84	29,70	*
4	13,30	843,0	8,30	1,30	0,41	2,22	*
5	8,30	8 143,0	4 369,00	2 094,00	696,00	0,50	*
6	17,60	4 576,0	17,20	3,10	0,69	1,08	*
7	19,30	2 921,0	10,20	1,70	0,35	1,40	*
8	6,80	34,0	3,20	0,60	0,28	48,70	*
9	8,60	3 554,0	18,20	4,10	0,92	1,39	*
10	18,70	10 039,0	257,90	14,40	2,48	1,03	*
11	21,80	552,0	37,80	11,40	3,77	4,09	*
12	20,50	260,0	0,90	0,20	0,05	8,09	*
13	8,80	35,0	2,70	0,60	0,05	50,08	*
14	10,60	518,0	4,50	0,30	0,17	4,14	*
15	23,00	202,0	1,60	0,30	0,00	6,26	*
16	40,40	13 367,0	304,20	13,20	0,59	1,03	*
17	10,70	1 695,0	40,20	6,30	2,20	1,98	*
18	175,60	2,9	0,55	0,18	0,07	408,00	*
19	27,90	12 011,0	506,70	35,00	3,21	1,08	*
20	6,14	27,6	7,00	1,94	0,85	51,40	*
21	5,75	73,7	15,30	5,00	2,05	22,90	*
22	79,60	1 680,0	70,00	5,70	0,00	3,98	*
23	32,30	305,0	0,60	0,20	0,03	21,84	*
24	42,20	4 137,0	48,70	2,20	1,08	1,19	113,6
25	65,70	72 967,0	5 777,00	430,00	103,00	1,00	337,3
26	72,70	447,0	5,10	0,90	0,50	4,56	61,4
27	32,60	10 447,0	155,20	15,20	6,80	1,07	122,8
28	32,30	70 498,0	10 428,00	2 176,00	626,00	1,02	298,8
29	24,70	53 930,0	4 517,00	513,00	132,00	1,00	305,6
30	26,40	12 176,0	323,00	28,00	5,00	1,06	88,7
31	35,30	61 844,0	8 988,00	2 229,00	739,00	1,03	299,6
32	70,20	99 097,0	6 090,00	650,00	100,00	1,01	297,0
33	58,60	62 113,0	4 563,00	687,00	213,00	1,08	304,5
34	73,60	55 430,0	2 433,00	253,30	60,00	1,01	310,3
35	68,90	53 283,0	3 553,00	500,00	157,00	1,01	271,5
36	58,50	55 947,0	2 970,00	210,00	43,30	1,13	260,6
37	74,90	63 170,0	2 997,00	253,00	40,00	1,01	299,8
38	30,00	4 796,0	39,20	0,96	0,32	1,35	80,8
39	19,10	21 840,0	3 660,00	1 127,00	482,00	1,03	166,1
40	29,70	4 136,0	95,40	22,30	9,40	1,23	38,6
41	*	1 043,0	10,50	1,47	0,53	2,20	*
42	33,90	7 323,0	152,20	23,80	11,20	1,07	98,2
43	*	584,3	10,30	1,73	0,90	3,36	*
44	6,50	13,5	3,50	0,77	0,30	130,22	14,3
45	10,60	18 491,0	1 053,00	73,30	9,30	1,05	111,7
46	18,40	1 003,0	13,00	0,33	0,13	2,30	23,4
47	36,60	4 710,0	66,70	5,60	2,70	1,12	106,9
48	40,10	5 419,0	118,00	26,70	16,00	1,28	105,7
49	109,90	8 222,0	430,00	41,00	2,30	3,36	*
50	198,40	224 576,0	32 152,00	6 168,00	1 492,00	1,01	1 691,6
51	16,40	1 121,0	10,70	1,50	0,66	1,94	34,6
52	37,30	1 791,0	33,20	6,60	2,50	1,60	75,3
53	40,10	1 997,1	39,80	2,90	1,10	1,58	20,2
54	111,90	11 559,0	220,00	13,20	4,00	1,06	133,7
55	20,10	20,1	3,50	1,17	0,53	72,30	25,1

Table 3 – Compilation of filter discrimination data (concluded)

Filter No.	Air cleaner fine test dust capacity grams	Downstream particle size distribution				Lowest Beta ratio	Final gravimetric mg/L
		Number > 10 $\mu\text{m}$ per mL	Number > 20 $\mu\text{m}$ per mL	Number > 30 $\mu\text{m}$ per mL	Number > 40 $\mu\text{m}$ per mL		
56	16,70	121,0	1,60	0,43	0,17	21,20	39,4
57	10,50	3 158,0	33,30	1,50	0,40	1,03	*
58	10,80	3 336,0	75,30	17,80	8,80	1,14	*
59	11,20	1 410,0	19,10	1,70	0,50	1,74	*
60	10,40	1 647,0	24,20	2,90	1,30	1,70	*
61	10,40	1 775,0	23,10	1,90	0,67	1,61	*
62	13,40	17,4	3,24	0,38	0,16	77,95	17,0
63	25,80	972,3	5,72	0,96	0,56	2,32	81,2
64	26,80	1 035,0	9,80	1,34	0,42	2,00	77,4
65	36,80	15 231,2	478,80	31,60	12,00	1,04	213,8
66	61,40	35,1	8,00	2,00	0,60	47,03	14,2
67	20,60	1 116,3	9,04	4,32	2,68	2,15	53,4
68	33,00	724,6	6,18	0,20	0,08	2,54	62,4
69	24,00	521,9	17,76	3,78	1,66	3,53	45,0

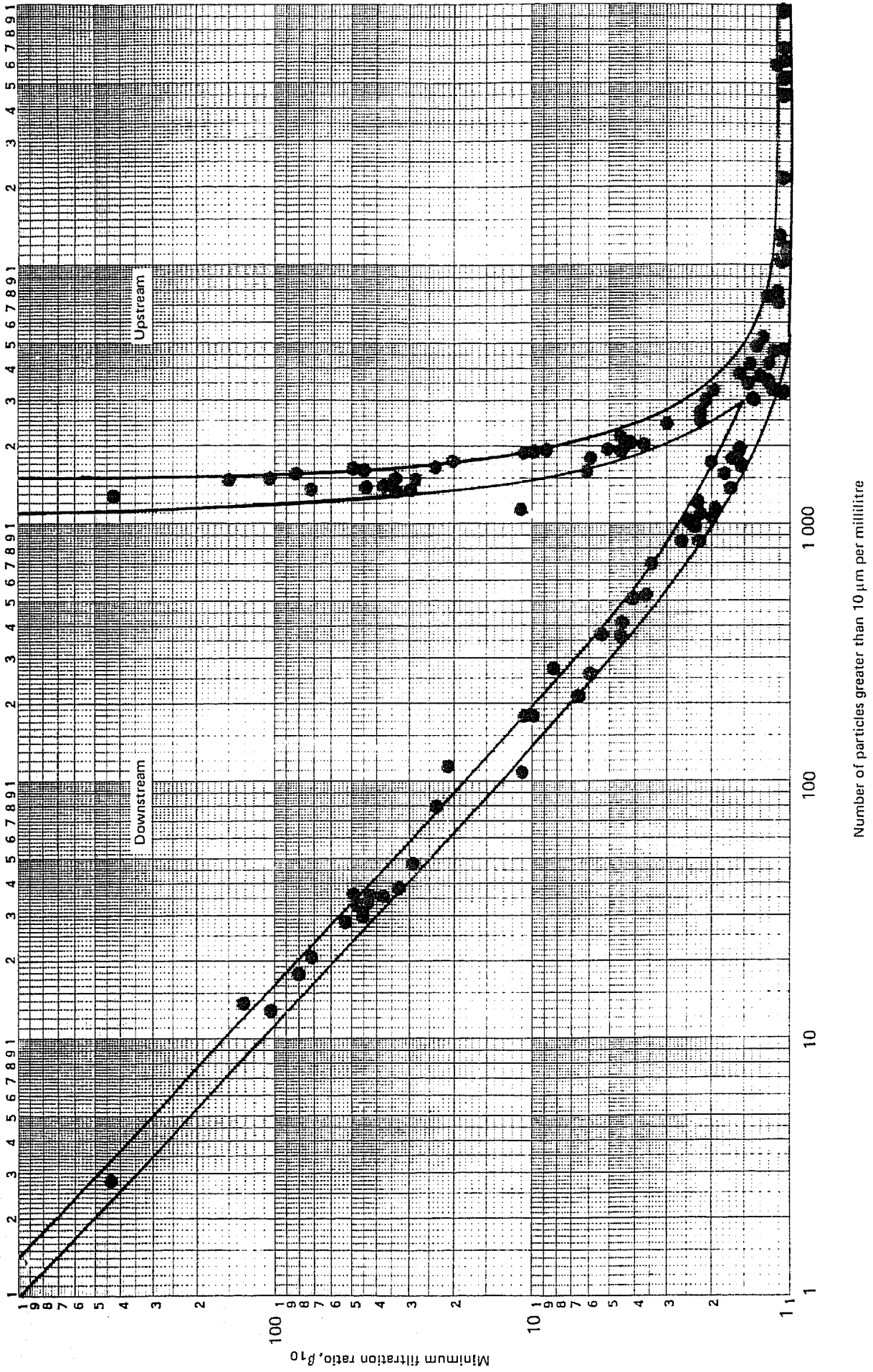

Figure 12 — Summary of test verification data and procedural control chart