**Methods of test for full-flow lubricating oil
filters for internal combustion engines —**

**Part 2:
Element by-pass valve characteristics**

*Méthodes d'essai des filtres à huile de lubrification à passage intégral pour
moteurs à combustion interne —*

Partie 2: Caractéristiques de l'organe de dérivation du filtre

This material is reproduced from ISO documents under International Organization for Standardization (ISO) Copyright License number IHS/ICC/1996. Not for resale. No part of these ISO documents may be reproduced in any form, electronic retrieval system or otherwise, except as allowed in the copyright law of the country of use, or with the prior written consent of ISO (Case postale 56, 1211 Geneva 20, Switzerland, Fax +41 22 734 10 79), IHS or the ISO Licensor's members.



Reference number
ISO 4548-2:1997(E)

Contents

1 Scope 1

2 Normative references 1

3 Definitions 1

4 Graphical symbols..... 1

5 Operational characteristics to be tested 1

6 Filter to be tested..... 2

6.1 Filter assembly..... 2

6.2 By-pass valve..... 2

7 Test rig..... 2

7.1 Sump..... 2

7.2 Regulating valves 2

7.3 Flow meter 3

7.4 Inlet and outlet pipes to the filter 3

7.5 Discharge pipe from sampling valve 3

8 Test liquids..... 5

9 Accuracy of test condition measurements 5

10 Test procedure..... 5

11 Report of test results..... 6

Annex A (informative) Bibliography 8

© ISO 1997

All rights reserved. Unless otherwise specified, no part of this publication may be reproduced or utilized in any form or by any means, electronic or mechanical, including photocopying and microfilm, without permission in writing from the publisher.

International Organization for Standardization
Case postale 56 • CH-1211 Genève 20 • Switzerland
Internet central@iso.ch
X.400 c=ch; a=400net; p=iso; o=isocs; s=central

Printed in Switzerland

Foreword

ISO (the International Organization for Standardization) is a worldwide federation of national standards bodies (ISO member bodies). The work of preparing International Standards is normally carried out through ISO technical committees. Each member body interested in a subject for which a technical committee has been established has the right to be represented on that committee. International organizations, governmental and non-governmental, in liaison with ISO, also take part in the work. ISO collaborates closely with the International Electrotechnical Commission (IEC) on all matters of electrotechnical standardization.

Draft International Standards adopted by the technical committees are circulated to the member bodies for voting. Publication as an International Standard requires approval by at least 75 % of the member bodies casting a vote.

International Standard ISO 4548-2 was prepared by Technical Committee ISO/TC 70, *Internal combustion engines*, Subcommittee SC 7, *Tests for lubricating oil filters*.

This second edition cancels and replaces the first edition (ISO 4548-2:1982), which has been technically revised.

ISO 4548 consists of the following parts, under the general title *Methods of test for full-flow lubricating oil filters for internal combustion engines*:

- *Part 1: Differential pressure/flow characteristics*
- *Part 2: Element by-pass valve characteristics*
- *Part 3: Resistance to high differential pressure and to elevated temperature*
- *Part 4: Initial particle retention efficiency, life and cumulative efficiency (gravimetric method)*
- *Part 5: Cold start simulation and hydraulic pulse durability test*
- *Part 6: Static burst pressure test*
- *Part 7: Vibration fatigue test*
- *Part 9: Inlet and outlet anti-drain valve tests*
- *Part 10: Life and cumulative efficiency in the presence of water in oil*
- *Part 11: Self-cleaning filters*
- *Part 12: Particle retention ability and contaminant holding capacity using particle counting*

Annex A of this part of ISO 4548 is for information only.

Introduction

ISO 4548 establishes standard test procedures for measuring the performance of full-flow lubricating oil filters for internal combustion engines. It has been prepared in separate parts, each part relating to a particular performance characteristic.

Together the tests provide the information necessary to assess the characteristics of a filter, but if agreed between the purchaser and the manufacturer, the tests may be conducted separately.

This revision of this part of ISO 4548 has been undertaken in order to align the presentation with the requirements of the current ISO Directives. The principal changes are editorial, affecting the layout and the text. Minor technical changes comprise the inclusion of ISO VG and SAE oil grades for the test liquids and the addition of a note concerning the specification of the valve opening pressure. In addition, the test rig dimensions have been modified to make them consistent with those specified in ISO 3968 and the flow meter has been repositioned downstream of the throttle valve.

Methods of test for full-flow lubricating oil filters for internal combustion engines —

Part 2: Element by-pass valve characteristics

1 Scope

This part of ISO 4548 specifies tests for determining the element by-pass valve characteristics of full-flow lubricating oil filters for internal combustion engines.

Tests are specified with oils at two viscosities, one to assess the performance of an element by-pass valve with a cold oil and the other to assess its performance with an oil at a typical operating temperature.

2 Normative references

The following standards contain provisions which, through reference in this text, constitute provisions of this part of ISO 4548. At the time of publication, the editions indicated were valid. All standards are subject to revision and parties to agreement based on this part of ISO 4548 are encouraged to investigate the possibility of applying the most recent editions of the standards indicated below. Members of IEC and ISO maintain registers of currently valid International Standards.

ISO 1219-1:1991, *Fluid power systems and components — Graphic symbols and circuit diagrams — Part 1: Graphic symbols.*

ISO 11841-1:—¹⁾, *Road vehicles and internal combustion engines — Filter vocabulary — Part 1: Definitions of filters and filter components.*

ISO 11841-2:—¹⁾, *Road vehicles and internal combustion engines — Filter vocabulary — Part 2: Definitions of characteristics of filters and their components.*

3 Definitions

For the purposes of this part of ISO 4548, the definitions given in ISO 11841-1 and ISO 11841-2 apply.

4 Graphical symbols

The graphical symbols used in this part of ISO 4548 are in accordance with ISO 1219-1.

5 Operational characteristics to be tested

The purpose of the element by-pass valve of a lubricating oil filter is to maintain an adequate supply of oil to the engine when the differential pressure across the filter element is high, even if the oil is not then filtered. Such conditions may occur, for example, when the engine is started from cold or in the event of the element becoming choked.

1) To be published.

To limit the quantity of unfiltered oil passed to the engine when there is no excessive differential pressure across the filter, it is customary for the by-pass valve to be designed not to open below a specified differential pressure and to allow leakage at no more than a specified rate when the differential pressure is not above the value.

To maintain an adequate oil supply to the engine when the filter element is completely choked, it is customary for the by-pass valve to be designed to pass the full oil flow with no more than a specified differential pressure. The tests specified in this part of ISO 4548 measure the differential pressure across the by-pass valve over the whole range of oil flow rates.

These tests include the requirement that a note shall be made of any noise emitted by the by-pass valve for example, due to valve oscillation. This is because there has been found to be a correlation between noise in these components and wear.

The differential pressure is measured across the complete filter assembly as described in 6.1.

6 Filter to be tested

6.1 Filter assembly

The filter element shall be removed from the filter and in its place there shall be installed a non-permeable dummy element of identical dimensions.

In the case of a filter whose element cannot readily be replaced by a non-permeable dummy element, for example a spin-on cartridge filter, the unit shall be opened and the by-pass valve shall be removed for testing in a separate housing, the design of which shall be agreed between the manufacturer and the purchaser of the filter.

6.2 By-pass valve

The filter by-pass valve for test, the test liquid and the test rig shall be clean. For the purpose of this part of ISO 4548, the term "clean" means that there is no detectable increase in differential pressure across a filter of the type under test (not modified in accordance with 6.1) when the test liquid at the test temperature is circulated through the test rig and the filter at the rated flow of the filter for 5 min.

7 Test rig

The test rig is shown diagrammatically in figure 1. It shall include the components described in 7.1 to 7.5, together with the necessary tubing, connectors and supports.

7.1 Sump

The sump shall be capable of holding sufficient oil and shall be equipped with a thermostatically controlled heater and cooler capable of maintaining the test temperature. The heater shall be arranged so that local overheating of the oil is avoided. The by-pass return to the sump and the filter outlet pipe shall terminate below the surface of the oil in the sump when the oil is in circulation. The temperature shall be arranged so that the stipulated viscosity is maintained.

7.2 Regulating valves

The regulating valves, 3 and 11, shall be used for the purposes of pressure and flow control. Needle valves or diaphragm type valves are recommended.

7.3 Flow meter

The flow meter shall be suitable for use with oils of $24 \text{ mm}^2/\text{s}$ ²⁾ and $500 \text{ mm}^2/\text{s}$ kinematic viscosity and shall register the flow in the pipeline leading to the filter. As an alternative, the flow meter may be installed at the filter outlet pipe. A calibrated measuring vessel and stop watch may be used.

7.4 Inlet and outlet pipes to the filter

The inlet and outlet pipe bores shall be equivalent to the sizes of the inlet and outlet ports of the filter. Alternatively, the sizes of the inlet and outlet pipes shall be as agreed between the manufacturer and the purchaser of the filter, for example to match the ports in the engine block on which the filter is to be used.

Tappings for the measurement of the differential pressure across the complete filter shall be made at five internal pipe diameters upstream of the filter inlet port and ten internal pipe diameters downstream from the filter outlet port. The inlet and outlet pipes shall be straight and free from obstruction for eight internal pipe diameters upstream and 13 internal pipe diameters downstream of the filter inlet and outlet ports.

7.5 Discharge pipe from sampling valve

To avoid draining the complete filter outlet pipe when the leakage rate is being measured, the free discharge pipe from the sampling valve **10** shall be taken to a height level with the filter under test.

NOTE — The discharge pipe is not shown in figure 1.

2) $1 \text{ mm}^2/\text{s} = 1 \text{ cSt}$

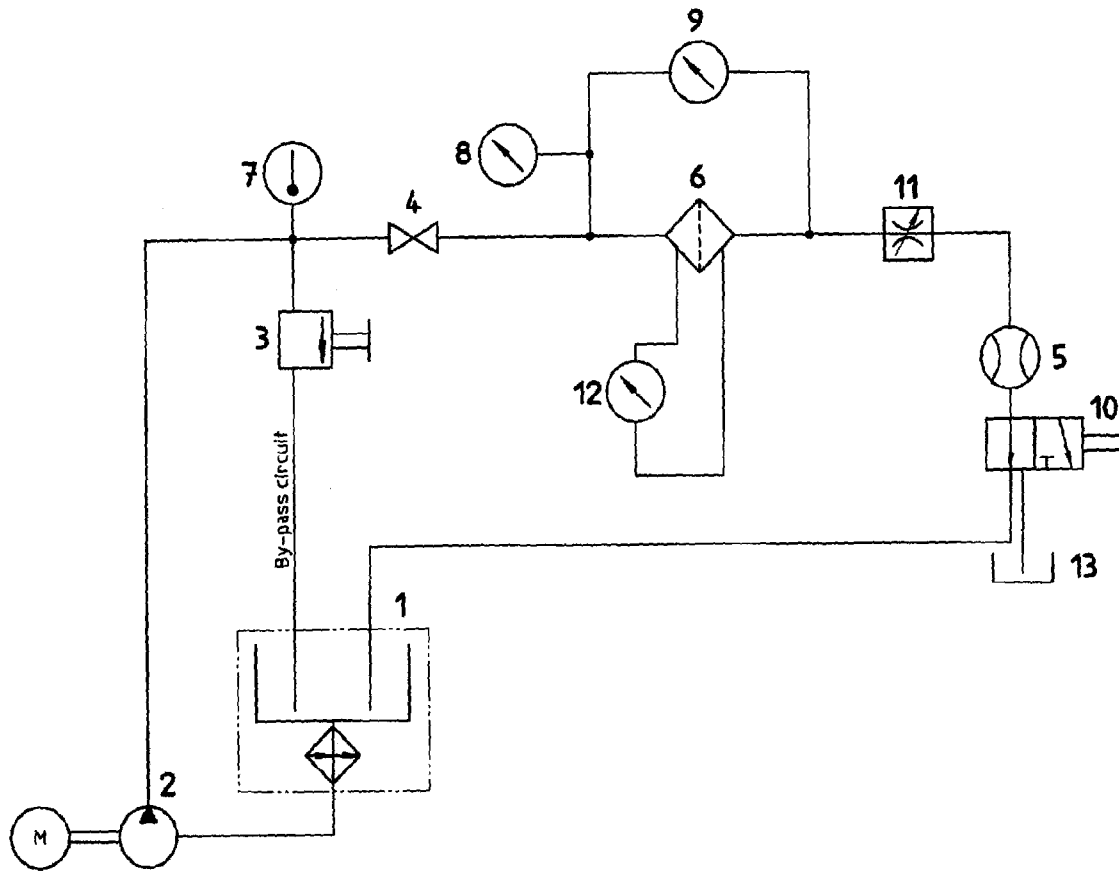

Key

- | | |
|---|--|
| <p>1 Sump (preferably insulated) incorporating a thermostatically controlled heater and cooler</p> <p>2 Motor-driven pump</p> <p>3 Throttle valve (for pressure regulation)</p> <p>4 ON-OFF valve</p> <p>5 Flow meter</p> <p>6 Filter under test</p> <p>7 Temperature sensor connected to a temperature indicator</p> <p>8 Pressure gauge</p> | <p>9 Differential pressure gauge or two single pressure gauges to measure the differential pressure across the filter by-pass component</p> <p>10 Valve in the filter outlet pipe to divert the flow into a measuring cylinder</p> <p>11 Throttle valve (for flow regulation)</p> <p>12 Differential pressure gauge or two single pressure gauges to measure the differential pressure across the filter by-pass component if required</p> <p>13 Free discharge pipe</p> |
|---|--|

Figure 1 — Diagrammatic arrangement of test rig

8 Test liquids

Unless otherwise agreed between the manufacturer and the purchaser of a filter, lubricating oils shall be selected and used in the tests at a suitable temperature to produce kinematic viscosities of 24 mm²/s for simulating general operating conditions and of 500 mm²/s when simulating cold conditions of operation. The temperature of the oils shall not exceed 100 °C.

NOTE 1 In order to achieve these viscosities it may be necessary to use two different oils.

A viscosity of 24 mm²/s can be achieved with ISO VG 100 (SAE 30) oil (see [1] and [3]) at an approximate temperature of 74 °C or ISO VG 150 (SAE 40) oil at an approximate temperature of 83 °C.

A viscosity of 500 mm²/s can be achieved with ISO VG 460 (SAE 140) oil (see [1] and [3]) at an approximate temperature of 38 °C.

NOTE 2 Intermingling of the two designated test oils may take place, particularly when alternating their use in the same test equipment. The magnitude of the resultant viscosity shift should be closely monitored, and compensation made for changes by altering the test temperature, or by partial or complete replacement of the test oils.

9 Accuracy of test condition measurements

Measurement of test conditions shall be maintained within the levels of accuracy given in table 1. Differential pressures shall be measured in kilopascals (kPa).

Table 1 — Measurement accuracies

Condition	Accuracy %
Differential pressure	± 5
Oil viscosity	± 5
Oil flow	± 2

10 Test procedure

10.1 Install the filter under test (modified in accordance with 6.1) in the test rig as shown in figure 1.

10.2 Add the required quantity of clean test liquid to the sump 1 and circulate it through the test rig via the by-pass pipe only. No test liquid shall pass through the filter at this stage.

10.3 Switch on the heater or cooler and adjust the thermostat to the required temperature (see clause 8). Allow the temperature to become stabilized.

10.4 When the temperature of the oil in the sump 1 has become stabilized, pass the liquid through the filter by-pass valve at approximately 50 % of the filter rated flow. Allow the temperature to become stabilized again. Bleed the system, if necessary.

10.5 When the temperature indicator 7 shows that the temperature of the oil at the filter inlet has become stabilized at the required value (see clause 8), prime the free discharge pipe from the sampling valve 10, the oil collected from it being returned to the sump. Reduce the flow through the filter by-pass valve to zero several times.

10.6 Slowly increase the inlet pressure to the element by-pass valve to a value 10 % below the specified minimum permissible opening pressure of the valve. Measure any leakage that occurs at this differential pressure by

collecting in a graduated cylinder the outflow from the sampling valve 10, the time taken to collect the sample being measured by a stop watch. Before collecting the sample, ensure that the leakage flow has stabilized.

NOTE — In the absence of a specification the valve opening pressure should be that at a flow rate of 1 l/min and a viscosity of 24 mm²/s.

10.7 Take measurements of the differential pressure across the element by-pass valve at each of at least eight flow rates at approximately equal increments up to 110 % of the filter rated flow, noting the opening pressure of the by-pass valve.

NOTE — The required flow is obtained by adjustment of the pressure and flow regulating valves, 3 and 11, ensuring that the inlet pressure exceeds the indicated differential pressure so that a positive pressure is maintained at the filter outlet. Each required value of flow rate should be approached from a lower value. The flow should be held constant for a period of not less than 10 s or until pressure readings have stabilized before taking each reading of differential pressure.

10.8 Decrease the flow and take measurements of the differential pressure across the element by-pass valve at the same rates of flow that were used in 10.7, and using the procedure detailed in 10.7 except that each required value of flow rate shall be approached from a higher value. Note the closing pressure of the by-pass valve.

10.9 When the differential pressure has been decreased to a value 10 % below the specified minimum opening pressure of the element by-pass valve, measure any leakage at this differential pressure in accordance with 10.6.

10.10 If noise is emitted by the element by-pass component during the test, note the rates of flow at which it occurs and the characteristic of the noise.

10.11 Carry out the procedure described in 10.2 to 10.10 for each viscosity oil.

11 Report of test results

A typical test report is given in figure 2. It shall include a graph showing, for each viscosity, the differential pressure across the element by-pass valve with respect to increasing and decreasing flow rates. Flow rates at which noise is emitted shall be marked along the contour of the curves.

Figure 2

Report on element by-pass valve test

- a) Testing establishment:.....
- b) Filter type
 manufacturer:
 model number and/or batch number (as appropriate)
- c) Date(s) of tests:
- d) Test liquid [24 mm²/s] (designation) at °C
 Test liquid [500 mm²/s] (designation) at °C
- e) Leakage rate at the specified minimum permissible opening pressure at 24 mm²/s:
 with increasing pressure: l/min
 with decreasing pressure: l/min
- f) The measured opening pressure of the by-pass valve at a specified flow rate (l/min) and
 viscosity (mm²/s): kPa
- g) Differential pressure at rated flow for 24 mm²/s and 500 mm²/s:
 with increasing pressure: kPa
 with decreasing pressure: kPa
- h) Provide a simple sketch of the by-pass valve test assembly and the position of the pressure tappings
- j) Graph of variations

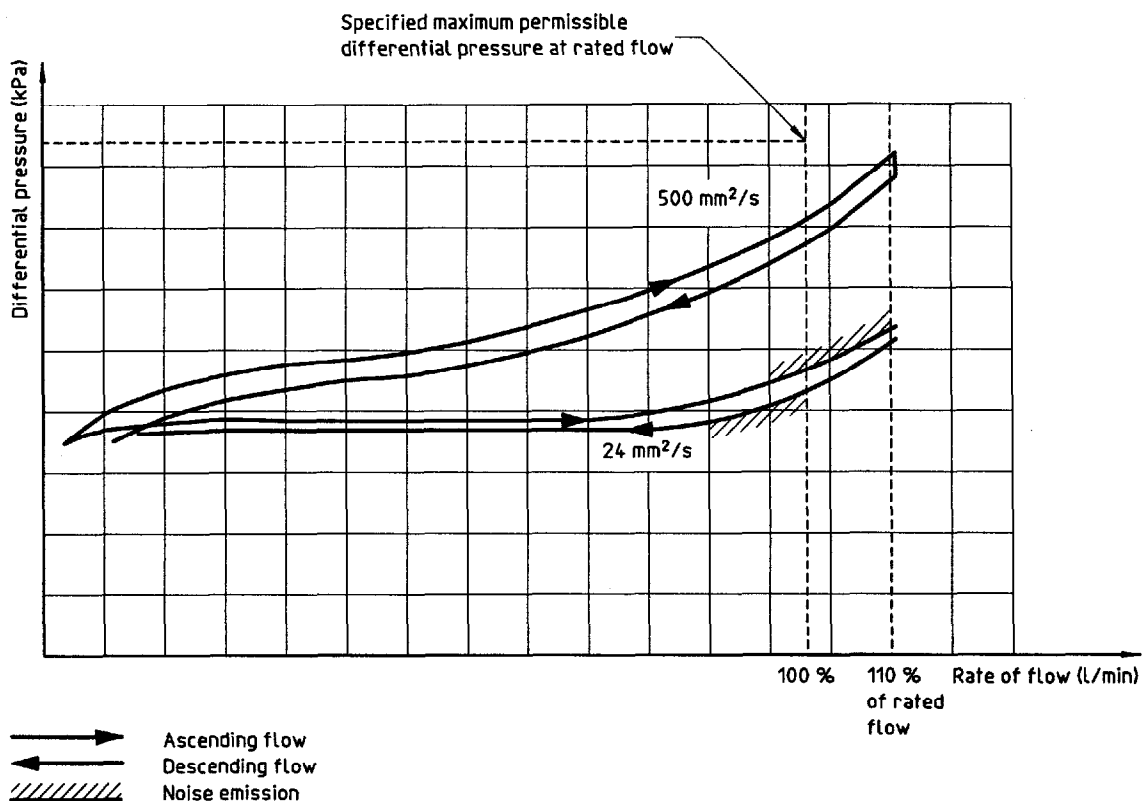

Figure 2 — Example of a test report

Annex A (informative)

Bibliography

- [1] ISO 3448:1992, *Industrial liquid lubricants — ISO viscosity classification.*
- [2] ISO 3968:1981, *Hydraulic fluid power — Filters — Evaluation of pressure drop versus flow characteristics.*
- [3] ANSI/SAE J300-MAR93, *Engine oil viscosity classification.*

ICS 27.020

Descriptors: internal combustion engines, lubrication systems, oil filters, tests, performance tests, test report sheets.

Price based on 8 pages
