

First edition
1997-09-15

**Methods of test for full-flow lubricating oil
filters for internal combustion engines —**

**Part 11:
Self-cleaning filters**

*Méthodes d'essai des filtres à huile de lubrification à passage intégral pour
moteurs à combustion interne —*

Partie 11: Filtres à nettoyage automatique

This material is reproduced from ISO documents under International Organization for Standardization (ISO) Copyright License number IHS/ICC/1996. Not for resale. No part of these ISO documents may be reproduced in any form, electronic retrieval system or otherwise, except as allowed in the copyright law of the country of use, or with the prior written consent of ISO (Case postale 56, 1211 Geneva 20, Switzerland, Fax +41 22 734 10 79), IHS or the ISO Licensor's members.



Reference number
ISO 4548-11:1997(E)

Contents

1 Scope 1

2 Normative references 1

3 Definitions 2

4 Graphical symbols 2

5 Test method for absolute rating (maximum particle diameter transmitted)..... 2

5.1 Principle 2

5.2 Test equipment and materials 2

5.3 Test procedure..... 5

5.4 Test results 6

6 Test method for pressure differential/flow characteristics 6

6.1 Principle 6

6.2 Test equipment and materials 6

6.3 Test procedure..... 6

6.4 Test results 8

7 Test methods for evaluation of gravimetric efficiency and self-cleaning ability of the complete filter 8

7.1 Principle 8

7.2 Test equipment and materials 8

7.3 Test procedure for continuous self-cleaning filters 10

7.4 Test procedure for intermittent self-cleaning filters..... 12

7.5 Test results 13

8 Test for resistance of the filtering element to high differential pressure 13

8.1 Principle 13

8.2 Test equipment and materials 14

© ISO 1997

All rights reserved. Unless otherwise specified, no part of this publication may be reproduced or utilized in any form or by any means, electronic or mechanical, including photocopying and microfilm, without permission in writing from the publisher.

International Organization for Standardization
Case postale 56 • CH-1211 Genève 20 • Switzerland
Internet central@iso.ch
X.400 c=ch; a=400net; p=iso; o=isocs; s=central

Printed in Switzerland

8.3 Test procedure	14
8.4 Test results	14
9 Test for resistance of the filtering element to elevated temperature	14
9.1 Principle	14
9.2 Test equipment and materials	14
9.3 Test procedure	16
9.4 Test results	16
10 Test for the effects of the presence of water	16
10.1 Principle	16
10.2 Test equipment and materials	16
10.3 Test procedure	16
10.4 Test results	17
11 Test for mechanical stability to alternating direction of flow	17
11.1 Principle	17
11.2 Test equipment and materials	17
11.3 Test procedure	19
11.4 Test results	19
11.5 Acceptance criteria	19
Annex A (informative) Examples of graphs of differential pressure versus time	20
Annex B (informative) Bibliography	22

Foreword

ISO (the International Organization for Standardization) is a worldwide federation of national standards bodies (ISO member bodies). The work of preparing International Standards is normally carried out through ISO technical committees. Each member body interested in a subject for which a technical committee has been established has the right to be represented on that committee. International organizations, governmental and non-governmental, in liaison with ISO, also take part in the work. ISO collaborates closely with the International Electrotechnical Commission (IEC) on all matters of electrotechnical standardization.

Draft International Standards adopted by the technical committees are circulated to the member bodies for voting. Publication as an International Standard requires approval by at least 75 % of the member bodies casting a vote.

International Standard ISO 4548-11 was prepared by Technical Committee ISO/TC 70, *Internal combustion engines*, Subcommittee SC 7, *Tests for lubricating oil filters*.

ISO 4548 consists of the following parts, under the general title *Methods of test for full-flow lubricating oil filters for internal combustion engines*:

- *Part 1: Differential pressure/flow characteristics*
- *Part 2: Element by-pass valve characteristics*
- *Part 3: Resistance to high differential pressure and to elevated temperature*
- *Part 4: Initial particle retention efficiency, life and cumulative efficiency (gravimetric method)*
- *Part 5: Cold start simulation and hydraulic pulse durability test*
- *Part 6: Static burst pressure test*
- *Part 7: Vibration fatigue test*
- *Part 9: Inlet and outlet anti-drain valve tests*
- *Part 10: Life and cumulative efficiency in the presence of water in oil*
- *Part 11: Self-cleaning filters*
- *Part 12: Particle retention ability and contaminant holding capacity using particle counting*

Annexes A and B of this part of ISO 4548 are for information only.

Introduction

ISO 4548 establishes standard test procedures for measuring the performance of full-flow lubricating oil filters for internal combustion engines. It has been prepared in separate parts, each part relating to a particular performance characteristic.

Together the tests provide the information necessary to assess the characteristics of a filter, but if agreed between the purchaser and the manufacturer, the tests may be conducted separately.

Methods of test for full-flow lubricating oil filters for internal combustion engines —

Part 11: Self-cleaning filters

1 Scope

This part of ISO 4548 specifies test methods for evaluating the characteristics of self-cleaning oil filters for internal combustion engines. It is applicable to filters in which self-cleaning is continuous or intermittent.

The removal of retained particles from the filter is achieved by periodic reversal of the direction of the fluid flow through the elements. However, this also applies mechanical stresses to the filter media. The tests specified in this standard are designed to check the filtration performance of the elements under simulated operating conditions and to confirm their ability to withstand, without damage, variations in oil pressure, temperature, direction of flow and the presence of water.

The equipment and procedures specified in this part of ISO 4548 are recommended for filters having a nominal flow rate of up to 1 600 l/min.

2 Normative references

The following standards contain provisions which, through reference in this text, constitute provisions of this part of ISO 4548. At the time of publication, the editions indicated were valid. All standards are subject to revision, and parties to agreements based on this part of ISO 4548 are encouraged to investigate the possibility of applying the most recent editions of the standards indicated below. Members of IEC and ISO maintain registers of currently valid International Standards.

ISO 1219-1:1991, *Fluid power systems and components — Graphic symbols and circuit diagrams — Part 1: Graphic symbols.*

ISO 2942:1994, *Hydraulic fluid power — Filter elements — Determination of fabrication integrity and determination of the first bubble point.*

ISO 3722:1976, *Hydraulic fluid power — Fluid sample containers — Qualifying and controlling cleaning methods.*

ISO 4405:1991, *Hydraulic fluid power — Fluid contamination — Determination of particulate contamination by the gravimetric method.*

ISO 4548-1:—¹⁾, *Methods of test for full-flow lubricating oil filters for internal combustion engines — Part 1: Pressure drop/flow characteristics.*

ISO 11841-1:—²⁾, *Road vehicles and internal combustion engines — Filter vocabulary — Part 1: Definitions of filters and filter components.*

1) To be published. (Revision of ISO 4548-1:1982)

2) To be published.

ISO 11841-2:—2), *Road vehicles and internal combustion engines — Filter vocabulary — Part 2: Definitions of characteristics of filters and their components.*

ISO 12103-1:—2), *Road vehicles — Test dust for filter evaluation — Part 1: Arizona test dust.*

3 Definitions

For the purposes of this part of ISO 4548, the definitions given in ISO 11841-1 and ISO 11841-2, together with the following definitions apply.

3.1 continuous self-cleaning filter

filter in which the process of cleaning the filtering elements operates permanently, irrespective of the operating conditions of the filter and the degree of blockage of the filtering medium

3.2 intermittent self-cleaning filter

filter in which the process of cleaning the filtering elements operates only when one of the characteristic operating parameters of the filter (time, pressure drop) reaches a predetermined value

3.3 retention capacity

mass of specific contaminant that the filtering element can retain at its nominal flow rate before its differential pressure reaches a specified value, such as the value that initiates self-cleaning

3.4 filtration efficiency

ability of the filter to retain particles contained in the fluid to be filtered

3.5 absolute rating

diameter, expressed in micrometres, of the largest non-deformable spherical particle capable of passing through the filtering element under predetermined test conditions

3.6 pressure

gauge pressure

4 Graphical symbols

The graphical symbols used in this part of ISO 4548 are in accordance with ISO 1219-1.

5 Test method for absolute rating (maximum particle diameter transmitted)

5.1 Principle

The test on the filtering element consists of filtering a suspension of calibrated glass microspheres at the nominal flow rate of the filtering element to be tested. A microscopic observation of all the spheres that have passed through the filtering element then allows measurement of the diameter of the largest sphere passing through.

The test gives an indication of the size of the largest pore of the filtering medium employed.

NOTE — The test applies only to the filtering element and not to the complete filter. However a test on the complete filter may be carried out by mutual agreement between the purchaser and the supplier.

5.2 Test equipment and materials

5.2.1 Test fluid

In the absence of any contrary agreement between the supplier and the purchaser of the filter, the oil for the test is to be a pure mineral oil with a kinematic viscosity as ISO VG 15 (see [1]), used at ambient temperature.

2) To be published.

5.2.2 Contaminant

The measurement of the maximum size of particle transmitted shall be carried out with glass microspheres with the particle size distribution given in table 1.

Table 1 — Particle size distribution of glass microspheres

Diameter μm	Mass %
< 20	5 ± 3
≥ 20 to < 40	10 ± 3
≥ 40 to < 60	20 ± 3
≥ 60 to < 100	30 ± 5
≥ 100 to < 200	35 ± 5

5.2.3 Measuring instruments

The measuring instruments shall be capable of measuring to the levels of accuracy given in table 2.

Table 2 — Accuracy of measuring instruments

Measurement	Accuracy %
Test flow rate	± 5
Relative pressure	± 2
Differential pressure	± 4
Temperature	± 1

5.2.4 Test rig

The test rig is shown diagrammatically in figure 1. It shall include the components described in 5.2.4.1 to 5.2.4.3.

5.2.4.1 Pressure regulator 1: capable of regulating the pressure maintained in the tank 6 to guarantee a flow of the fluid in the filter under test 10 at its nominal flow rate. Tests shall be conducted to determine the oil flow rate/air pressure curve.

5.2.4.2 Centrifugal pump 13: capable of providing a turbulent flow of $Re > 3\,000$ in the pipelines.

5.2.4.3 Purification filter 15: capable of maintaining a level of particulate contamination of the circuit less than or equal to 2 mg/l, in accordance to ISO 4405.

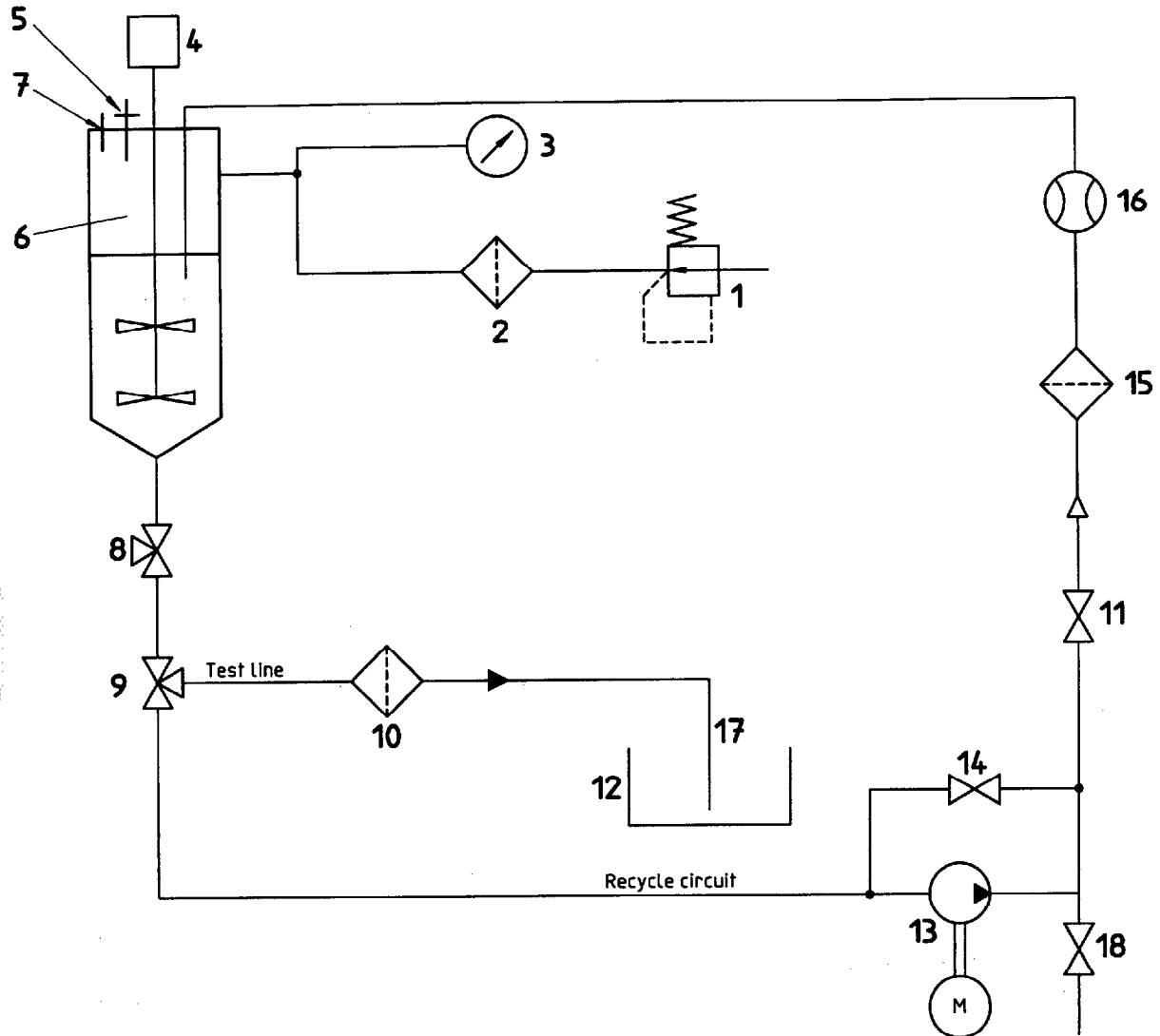

Key

- | | |
|---|----------------------------------|
| 1 Air pressure regulator | 10 Test filter |
| 2 Filter (< 0,8 μm) | 11 Isolating valve |
| 3 Inlet pressure gauge | 12 Sample bottle |
| 4 Agitator (1 500 r/min to 2 000 r/min) | 13 Centrifugal pump |
| 5 Relief valve | 14 Isolating valve |
| 6 Mixing tank (5 l capacity) | 15 Purification filter |
| 7 Contaminant inlet orifice | 16 Flow meter |
| 8 Isolating valve | 17 New and clean flexible tubing |
| 9 Three-way valve | 18 Sampling valve |

Figure 1 — Test rig for measurement of maximum particle diameter transmitted

5.3 Test procedure

5.3.1 Preparation of the test rig

5.3.1.1 Fill the mixing tank 6 with 4 l of test fluid and open isolating valves (8, 11 and 14).

5.3.1.2 Set the three-way valve 9 to allow oil to flow through the recycle circuit.

5.3.1.3 Start the pump 13 and slowly close valve 14 causing the fluid to flow through the purification filter for about 30 min.

5.3.1.4 Take a sample of fluid at valve 18 and check that its particulate contamination level is less than or equal to 2 mg/l in accordance with ISO 4405.

5.3.1.5 If the contamination level is not satisfactory, continue purification or install a more efficient purification filter 15.

5.3.1.6 If the contamination level is satisfactory, stop the pump 13, close isolating valves (8, 11 and 14) and set the three-way valve 9 to allow the oil to flow to the test line.

5.3.2 Integrity check

Check the integrity of the filtering element in accordance with ISO 2942.

5.3.3 Filter test

NOTE — The test flow rate should not be greater than 20 l/min. If the filtering element to be tested has a designated flow rate less than 20 l/min, it should be tested at that flow rate. If the designated flow rate is greater than 20 l/m, the test should be performed using an element with identical technology and construction, but with reduced height so that the flow velocity of the fluid through the element under test is the same as for the element to be qualified.

5.3.3.1 Mount the filtering element in the filter body, or test housing, of the test filter 10 and install the assembly on the test rig.

5.3.3.2 Start up the agitator 4.

5.3.3.3 Through orifice 7, using a clean funnel prepared in accordance with ISO 3722, introduce 0,025 g of contaminant previously mixed in 5 cm³ of test fluid.

5.3.3.4 Remove the funnel, close the orifice 7 and allow to mix for 3 min.

5.3.3.5 Downstream from the test filter, connect a flexible tube which has never been in contact with the glass spheres.

5.3.3.6 Using the air pressure regulator 1, pressurize the mixing tank to obtain the designated flow rate through the filtering element.

5.3.3.7 Place a clean sample bottle 12, which is free of glass spheres, below the flexible tube 17.

5.3.3.8 Open valve 8, allow all the test fluid to pass through the filtering element 10 and collect it in the clean sample bottle 12.

5.3.3.9 Close valve 8 as soon as air appears and close the air pressure regulator 1.

5.3.3.10 Analyze all the fluid collected as follows:

- a) filter on a 5 µm, 47 mm diameter membrane using a vacuum flask;
- b) rinse the membrane with a solvent prefiltered at 1 µm;
- c) heat the membrane in an oven for 20 min at 80 °C;

- d) using a microscope, examine the entire effective area of the membrane, and measure the diameter of the largest spheres observed.

5.4 Test results

The maximum size of particle transmitted through the filtering element is expressed in micrometres and its value is that of the diameter of the largest glass sphere observed on the membrane.

6 Test method for pressure differential/flow characteristics

6.1 Principle

The filter is subjected to increasing and then decreasing values of fluid flow rate to determine the variation in differential pressure as a function of flow rate.

If the temperature of the filtered fluid varies, its viscosity changes. The differential pressure test conducted with a high viscosity fluid serves to simulate the differential pressure that it generates, for example, on cold starting of the engine.

NOTE — The test is performed on a complete filter.

6.2 Test equipment and materials

6.2.1 Test fluid

In the absence of any contrary agreement between the supplier and the purchaser of the filter, the oil used for the test is to be a pure mineral oil with a kinematic viscosity as ISO VG 150.

6.2.2 Measuring instruments

See 5.2.3.

6.2.3 Test rig

The test rig is shown diagrammatically in figure 2.

Tappings for the measurement of the differential pressure across the complete filter shall be made at five internal pipe diameters upstream of the filter inlet port and 10 internal pipe diameters downstream from the filter outlet port. The inlet and outlet pipes shall be straight and free from obstruction for eight internal pipe diameters upstream and 13 internal pipe diameters downstream of the filter inlet and outlet ports. A complete description of the installation is given in ISO 4548-1:—¹⁾, clause 7.

6.3 Test procedure

6.3.1 Preparation of the test rig

Without a test filter mounted in the test rig:

- a) set isolating valves 13 to bring the purification filter 12 into the circuit;
- b) start up the pump 2 and regulate the flow rate to 1,2 times the flow rate specified by the supplier;
- c) allow the fluid to flow for sufficient time to stabilize the temperature at the value specified for the test and provide a contamination level less than 10 mg/l measured in accordance with ISO 4405.

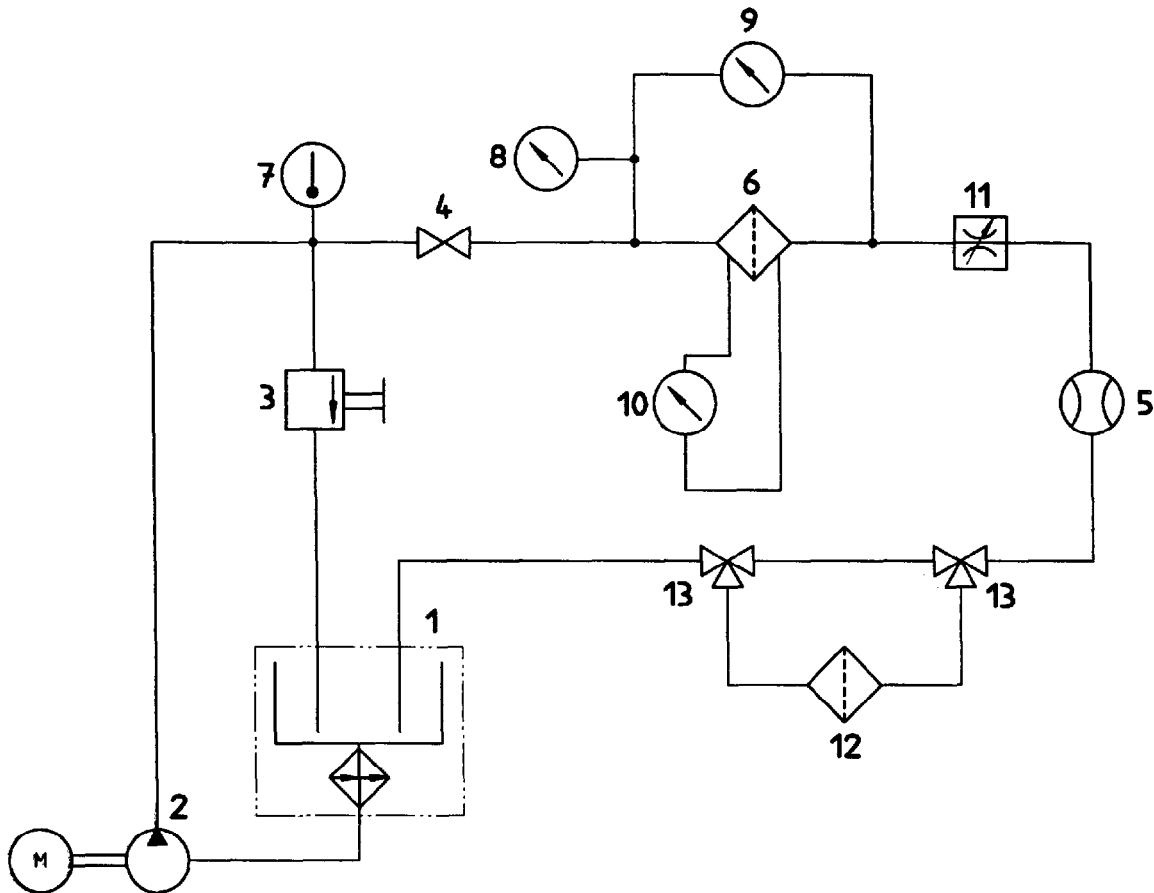

Key

- | | |
|--|---|
| <ul style="list-style-type: none"> 1 Oil tank incorporating a thermostatically controlled heater and cooler 2 Motor pump unit 3 Throttle valve (for pressure regulation) 4 Isolating valve 5 Flow meter 6 Test filter 7 Temperature sensor connected to a temperature indicator 8 Pressure gauge | <ul style="list-style-type: none"> 9 Differential pressure gauge, or two single pressure gauges (to measure the differential pressure across the filter) 10 Differential pressure gauge, or two single pressure gauges (to measure the differential pressure across the filtering elements) 11 Throttle valve (for flow rate regulation) 12 Purification filter 13 Isolating valve |
|--|---|

Figure 2 — Test rig for evaluation of differential pressure as a function of fluid flow rate and viscosity

6.3.2 Measurement of differential pressure

Proceed as described in ISO 4548-1.

6.4 Test results

Report the test results in accordance with ISO 4548-1.

7 Test methods for evaluation of gravimetric efficiency and self-cleaning ability of the complete filter

7.1 Principle

A particulate contaminant, with known concentration and particle size distribution, is introduced upstream to the self-cleaning filter under test. The efficiency is measured by comparing the mass concentration of the contaminant, at the inlet and outlet of the filter.

The samples are taken at various times during one or more filter cleaning cycles, in order to determine its gravimetric efficiency at different degrees of blockage.

NOTE — The tests are performed on a complete filter.

7.2 Test equipment and materials

7.2.1 Test fluid

In the absence of any contrary agreement between supplier and purchaser of the filter, the oil used for the test is to be a pure mineral oil which should have a kinematic viscosity as ISO VG 150.

The test fluid temperature shall be maintained at $70\text{ °C} \pm 3\text{ °C}$.

7.2.2 Test contaminant

The contaminant shall be a test dust with the particle size distribution specified for ISO 12103-A4 (ISO Coarse)³⁾.

7.2.3 Measuring instruments

See 5.2.3.

7.2.4 Test rig

The test rig is shown diagrammatically in figure 3.

Tappings for the measurement of the differential pressure across the complete filter shall be made at five internal pipe diameters upstream of the filter inlet port and 10 internal pipe diameters downstream from the filter outlet port. The inlet and outlet pipes shall be straight and free from obstruction for eight internal pipe diameters upstream and 13 internal pipe diameters downstream of the filter inlet and outlet ports.

3) See ISO 12103-1.

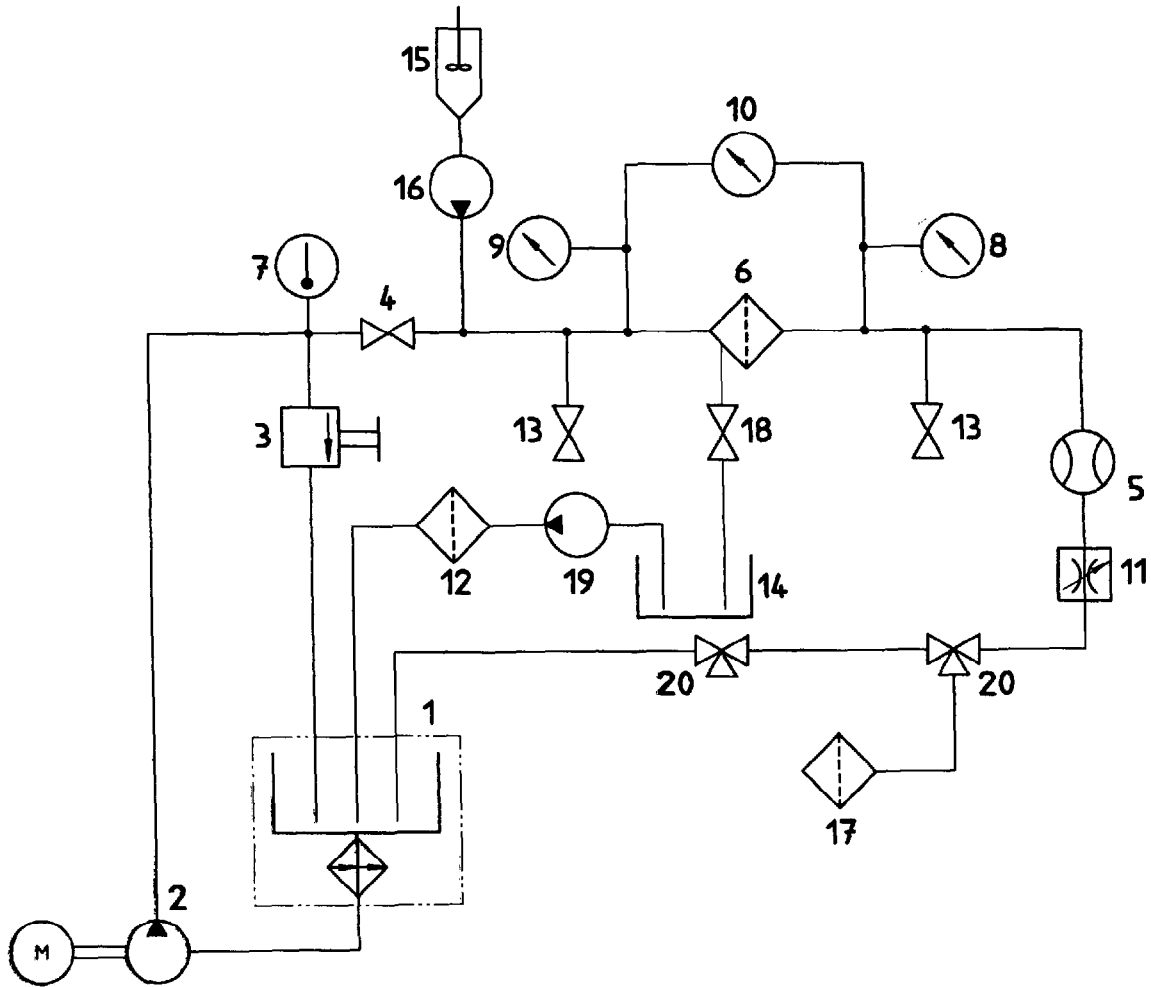

Key

- | | |
|--|--|
| <p>1 Oil tank incorporating a thermostatically controlled heater and cooler</p> <p>2 Motor pump unit</p> <p>3 Throttle valve (for pressure regulation)</p> <p>4 Isolating valve</p> <p>5 Flow meter</p> <p>6 Test filter</p> <p>7 Thermometer</p> <p>8 Filter outlet pressure gauge</p> <p>9 Filter inlet pressure gauge</p> <p>10 Differential pressure gauge</p> | <p>11 Throttle valve (for flow regulation)</p> <p>12 Purification filter on secondary circuit</p> <p>13 Sampling tap</p> <p>14 Collection tank for back flushing oil</p> <p>15 Contaminant injection tank</p> <p>16 Contaminant injection pump</p> <p>17 Clean-up filter on main circuit</p> <p>18 Oil outlet valve of self-cleaning function</p> <p>19 Transfer pump</p> <p>20 Three-way valves</p> |
|--|--|

Figure 3 — Test rig for evaluation of gravimetric efficiency and cleaning ability

7.3 Test procedure for continuous self-cleaning filters

7.3.1 Preparation of the test rig

- 7.3.1.1 Replace the filter under test with an empty housing or a pipe of the same length as the filter.
- 7.3.1.2 Bring the clean-up filter 17 on-line.
- 7.3.1.3 Start up the main pump 2 and set at the maximum flow rate possible by shutting the flow-control valve 3.
- 7.3.1.4 Switch on the heating system.
- 7.3.1.5 Allow to circulate for sufficient time to allow stabilization of the fluid temperature at $70\text{ °C} \pm 3\text{ °C}$ and to clean the fluid to a particulate contamination level of less than 10 mg/l (measured in accordance with ISO 4405).
- 7.3.1.6 When the cleanliness level is reached, stop the circulating pump 2 and bypass the clean-up filter 17.
- 7.3.1.7 If the cleanliness level is not reached within a reasonable time interval, check the assembly of the clean-up filter or install a more efficient filtering element.

7.3.2 Preparation of the injection circuit

7.3.2.1 Depending on the total volume, V_m , of the fluid contained in the injection tank, the mass of contaminant, m_c , to be introduced into the injection tank is determined as follows:

$$m_c = V_m C_i$$

in which

$$C_i = C_o q_o / q_i$$

where

- q_o is the test flow rate defined by the supplier's specification, in litres per minute;
- C_o is the contaminant concentration upstream from the test filter, in milligrams per litre, set at 100 mg/l;
- q_i is the flow rate of contaminant injection circuit, in litres per minute;
- C_i is the contaminant concentration in the injection tank, in milligrams per litre.

7.3.2.2 Fill the injection tank 15 with a volume V_m of test fluid.

7.3.2.3 Start the agitator.

7.3.2.4 Mix the contaminant (of mass m_c) which has been previously dried (by heating at a temperature between 90 °C and 150 °C for one hour), and then dilute with part of the injection tank test fluid and homogenize by an ultrasonic mixing method.

7.3.2.5 Add the dust mixture to the injection tank. Check the injection pump 16 flow rate is correctly set and that it provides a constant flow rate and injection concentration in all circumstances.

7.3.3 Test for measurement of initial pressure drop

NOTES

- 1 New filter elements should be used for this test.
- 2 See figure A.1 for an example of a graph of differential pressure versus time.

7.3.3.1 Install the test filter on the rig as shown in figure 3, with its self-cleaning function in operation.

7.3.3.2 Start the main oil pump 2.

7.3.3.3 Adjust the test liquid flow rate to $\pm 5\%$ of the designated flow rate for the filter, ensuring that the pressure at the filter outlet is kept at $3 \text{ bar} \pm 0,2 \text{ bar}^4$) by using the manual flow reducer 11 and the flow-control valve 3.

7.3.3.4 Operate the self-cleaning filter without injecting contaminant.

7.3.3.5 Record the value of the initial differential pressure dp_1 of the clean filter.

7.3.4 Test to determine a stable differential pressure with the self-cleaning function operational

NOTES

- 1 The filter elements that were fitted for the test described in 7.3.3 should also be used for this test.
- 2 See figure A.1 for an example of a graph of differential pressure versus time.

7.3.4.1 At time t_1 , start the injection pump 16.

7.3.4.2 Record the value of the pressure drop across the filter under test.

7.3.4.3 Allow the self-cleaning filter to operate until the differential pressure is stable (e.g. time t_2).

7.3.4.4 Record the differential pressure dp_{i2} when it is stable.

7.3.5 Test for blocking of filter with self-cleaning function non-operational

NOTES

- 1 The filter elements that were fitted for the test described in 7.3.3 should also be used for this test.
- 2 See figure A.1 for an example of a graph of pressure drop versus time.

7.3.5.1 At time t_2 , stop the filter's self cleaning function.

7.3.5.2 With the injection pump 16 running, record the time t elapsed between time t_2 and t_3 , at which the pressure drop has increased by 0,5 bar with respect to the initial pressure drop dp_{i2} .

7.3.5.3 At time t_3 , take three 200 ml samples of fluid from the sample tap 13 upstream and three samples from the sample tap 13 downstream of the filter under test.

7.3.5.4 Determine the test dust concentrations of each sample by the gravimetric method according to ISO 4405.

7.3.5.5 Calculate the arithmetic mean for the upstream test dust concentrations and denote C_u . Repeat for the downstream test dust concentrations and denote C_b .

7.3.6 Test for efficiency during self-cleaning

NOTES

- 1 The filter elements that were fitted for the test described in 7.3.3 should also be used for this test.
- 2 See figure A.1 for an example of a graph of pressure drop versus time.

7.3.6.1 At time t_3 , restart the self-cleaning function.

7.3.6.2 Record the time (t_3 to t_4) required to return to the initial pressure drop $dp_{i2} \pm 10\%$.

NOTE — At time t_4 the value of dp should be less than $dp_{i2} + 0,1 \text{ bar}$.

4) 1 bar = 100 kPa

7.3.6.3 Allow the test to continue, with the self-cleaning function and the contaminant injection pump operating for a period equal to $5(t_4 - t_3)$, or at least two hours.

NOTE — From time t_4 to t_5 (operation of the filter with the self cleaning function) the value of dp must remain within the limits dp_{12} and $dp_{12} + 0,1$ bar.

7.3.6.4 At the end of the steady-state operating period (t_5), take three 200 ml fluid samples from the valves 13 upstream and downstream from the filter.

7.3.6.5 Measure the mass concentration of the six samples by the gravimetric method in accordance with ISO 4405. Calculate the arithmetic mean and denote the upstream sample mean, C_u , and the downstream sample mean, C_d .

NOTES

- 1 During the operation of the filter from time t_1 to t_5 , upstream contaminant concentration should be maintained at 100 mg/l.
- 2 It is not necessary to take samples for gravimetric efficiency analysis during these tests.

7.3.7 Additional tests (five further blocking and cleaning cycles)

NOTES

- 1 These tests may be performed on the filter immediately after the test described in 7.3.6. to assess the ability of the filter to resist progressive fouling.
- 2 See figure A.2 for an example of a graph of differential pressure versus time.

7.3.7.1 Repeat the tests described in 7.3.5 and 7.3.6 for a further five cycles.

NOTE — It is not necessary to take samples for gravimetric efficiency analysis during these tests.

7.3.7.2 At the end of each cycle ($t_8, t_{11}, t_{14}, t_{17}$ and t_{20}) note the value of dp which should remain between dp_{12} and $dp_{12} + 10\%$. Progressive fouling is evident if the value of dp gradually increases above $dp_{12} + 10\%$.

NOTE — The value of dp_{12} is determined in 7.3.4.4.

7.4 Test procedure for intermittent self-cleaning filters

7.4.1 Preparation of the test rig

Proceed as described in 7.3.1.

7.4.2 Preparation of the injection circuit

Proceed as described in 7.3.2.

7.4.3 Tests for filtration and cleaning

NOTE — See figure A.3 for an example of a graph of differential pressure versus time.

7.4.3.1 Measurement of initial differential pressure

NOTE — New filtering elements should be used for this test.

7.4.3.1.1 Install the filter to be tested in the test rig as shown in figure 3, with its self-cleaning function in service.

7.4.3.1.2 Adjust the test fluid flow rate to $\pm 5\%$ of the designated flow rate of the filter, ensuring that the pressure at the filter outlet is maintained at $3 \text{ bar} \pm 0,2 \text{ bar}$ by using the flow reducer 11 and the flow-control valve 3.

7.4.3.1.3 Record the value of the initial differential pressure (dp_{i1}) of the clean filter.

7.4.3.2 Blocking and cleaning tests

7.4.3.2.1 At time t_0 start the contaminant injection pump to obtain a theoretical concentration of 100 mg/l upstream from the filter to be tested.

7.4.3.2.2 Record the times elapsed between blocking (t_0 to t_1 , t_2 to t_3 etc.) and cleaning (t_1 to t_2 , t_3 to t_4 etc.) ensuring that the blocking and cleaning times are identical throughout the test.

NOTE — dp_{12} and dp_{13} should be constant throughout the test.

7.4.3.2.3 Allow the intermittent self-cleaning filter to run for five cycles or two hours of cleaning (see figure A.3).

7.4.3.2.4 At the end of five cycles (time t_{10}) take three 200 ml fluid samples from the sampling taps 13, upstream and downstream of the filter.

7.4.3.2.5 Measure the mass concentration of each sample by the gravimetric method in accordance with ISO 4405. Calculate the arithmetic mean and denote the upstream sample mean C_u and the downstream sample mean C_d .

7.5 Test results

7.5.1 Continuous self-cleaning

Two efficiencies are recorded during the tests with the continuous self-cleaning filter. One efficiency is recorded when the self-cleaning function is switched off and the other when the self-cleaning function is operating.

7.5.1.1 Calculate the efficiency of the filter, E , with the continuous cleaning function non-operational, as a percentage using the equation:

$$E = \frac{C_a - C_b}{C_a} \times 100$$

Where C_a and C_b are the arithmetic means of the test dust concentrations obtained at t_3 (see figure A.1).

7.5.1.2 Calculate the efficiency of the filter, E , during continuous cleaning using the equation:

$$E = \frac{C_c - C_d}{C_c} \times 100$$

Where C_c and C_d are the arithmetic means of the test dust concentrations obtained at t_5 (see figure A.1).

7.5.2 Intermittent self-cleaning

Calculate the efficiency of the filter, E , during intermittent cleaning, using the equation:

$$E = \frac{C_e - C_f}{C_e} \times 100$$

Where C_e and C_f are the arithmetic means of the test dust concentrations obtained at t_{10} (see figure A.3).

8 Test for resistance of the filtering element to high differential pressure

8.1 Principle

The objective of the test is to ensure that the filtering element satisfactorily withstands an exceptionally high differential pressure. Blocking is achieved artificially by injecting a particulate contaminant.

NOTE — The test applies only to the filtering element and not to the complete filter. However, the test on the complete filter may be carried out by mutual agreement between the purchaser and the supplier.

8.2 Test equipment and materials

8.2.1 Test fluid

See 7.2.1.

8.2.2 Test contaminant

See 7.2.2.

8.2.3 Measuring instruments

See 5.2.3.

8.2.4 Test rig

The test rig is shown diagrammatically in figure 3.

8.3 Test procedure

NOTE — The pump should be capable of providing a 10 bar pressure drop across the filter.

8.3.1 Check the integrity of the filtering element according to ISO 2942.

8.3.2 Install the test filter on the rig as indicated in figure 3, with the self-cleaning function off. The discharge valve 18 for the self-cleaning function should be closed.

8.3.3 Switch on the heating system and circulate the oil at the test flow rate.

8.3.4 Prepare the contaminant injection system as described in 7.3.2.

8.3.5 Inject contaminant until the pressure drop across the filtering element reaches 10 bar, and maintain this pressure drop for two minutes.

8.4 Test results

8.4.1 Remove the filtering element and purge the excess oil. No visible deformation or damage should be observable to the naked eye.

8.4.2 Check the integrity of the filtering element according to ISO 2942.

9 Test for resistance of the filtering element to elevated temperature

9.1 Principle

The test is intended to simulate an abnormal temperature rise in the engine. It consists of flowing hot oil through the filter and ensuring that none of the component parts of the filter (assemblies, gaskets, etc.) have been damaged by the heat.

NOTE — The test is performed on a complete filter using new filter elements.

9.2 Test equipment and materials

9.2.1 Tests fluid

See 6.2.1.

9.2.2 Measuring instruments

See 5.2.3.

9.2.3 Test rig

The test rig is shown diagrammatically in figure 4.

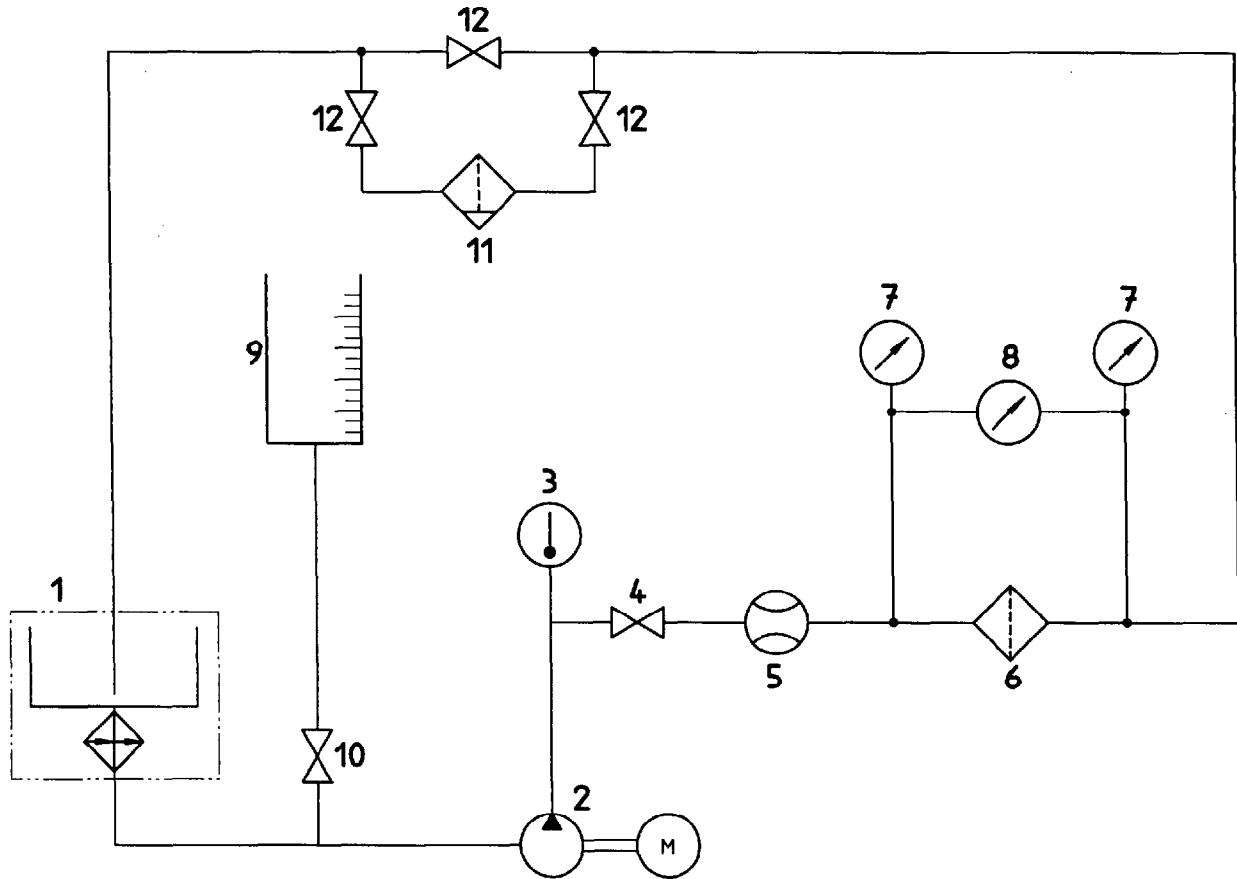

Key

- 1 Oil tank incorporating a thermostatically controlled heater and cooler
- 2 Motor pump unit
- 3 Thermometer
- 4 Isolating valve
- 5 Flow meter
- 6 Filter to be tested
- 7 Pressure gauge
- 8 Differential pressure gauge
- 9 Graduated water container
- 10 Adjusting valve
- 11 Water separator filter
- 12 Isolating valve

Figure 4 — Test rig for evaluation of filtering element resistance to elevated temperature

9.3 Test procedure

9.3.1 Check the integrity of the filtering element in accordance with ISO 2942.

9.3.2 Install the complete filter on the rig as shown in figure 4.

9.3.3 Switch on the heating system and circulate the oil at $100\text{ °C} \pm 3\text{ °C}$ at the designated flow rate of the test filter for at least eight hours.

9.4 Test results

9.4.1 By visual inspection, ensure the absence of any deformation or damage to the filter components (especially gaskets and seals) after dismantling.

9.4.2 Check the integrity of the tested filtering element in accordance with ISO 2942.

10 Test for the effects of the presence of water

10.1 Principle

Certain engine lubricating oils contain an excessive amount of dissolved or undissolved water which may affect the functional characteristics of the filtering media.

The objective of the test is to confirm that the filter will withstand a high content of water and that its functions, particularly cleaning, remain operational.

NOTE — The test is performed on a complete filter using new filter elements.

10.2 Test equipment and materials

10.2.1 Test fluid

See 7.2.1.

10.2.2 Measuring instruments

See 5.2.3.

10.2.3 Test rig

The test rig is shown diagrammatically in figure 4.

10.3 Test procedure

10.3.1 Check the integrity of the filter element in accordance with ISO 2942.

10.3.2 Fill the oil storage tank with a volume of oil, in litres, equal to half of the test flow rate in litres per minute.

10.3.3 Switch on the heating system to obtain an oil temperature of $70\text{ °C} \pm 3\text{ °C}$.

10.3.4 Bring the coalescing water separator filter 11 on-line and operate the pump 2 at the maximum flow rate of the test rig until a residual free water content of 50 ppm is obtained.

10.3.5 Install the filtering elements to be tested in the filter or the test box and mount it on the test rig.

10.3.6 Switch on the self-cleaning function of the filter.

10.3.7 Adjust the flow rate to the value specified by the supplier.

10.3.8 Record the initial pressure drop.

10.3.9 Through valve **10**, upstream from the pump **2**, and for one to two minutes, inject a sufficient volume of water to obtain a final water content of 5 % in the rig, calculated on the basis of the total volume of fluid contained in the test rig.

10.3.10 Circulate the mixture for at least 20 min after the end of water injection.

10.3.11 Record the pressure drop across the filter.

10.4 Test results

10.4.1 Remove the filtering elements and examine the filter for any deformation or damage visible to the naked eye.

10.4.2 Check the integrity of the filtering element in accordance with ISO 2942.

11 Test for mechanical stability to alternating direction of flow

11.1 Principle

In normal operating conditions, an intermittent or continuous self-cleaning filter imposes an alternating flow direction of the fluid through the filtering element, corresponding to the filtration and self-cleaning phases.

This reversal subjects the filtering material to mechanical stresses applied alternately in the normal and reverse direction of the flow.

The test is intended to ensure that stress does not damage the filter element.

NOTE — The test applies only to the filtering element and not to the complete filter.

11.2 Test equipment and materials

11.2.1 Test fluids

See 7.2.1.

11.2.2 Measuring instruments

See 5.2.3.

11.2.3 Test rig

The test rig is shown diagrammatically in figure 5.

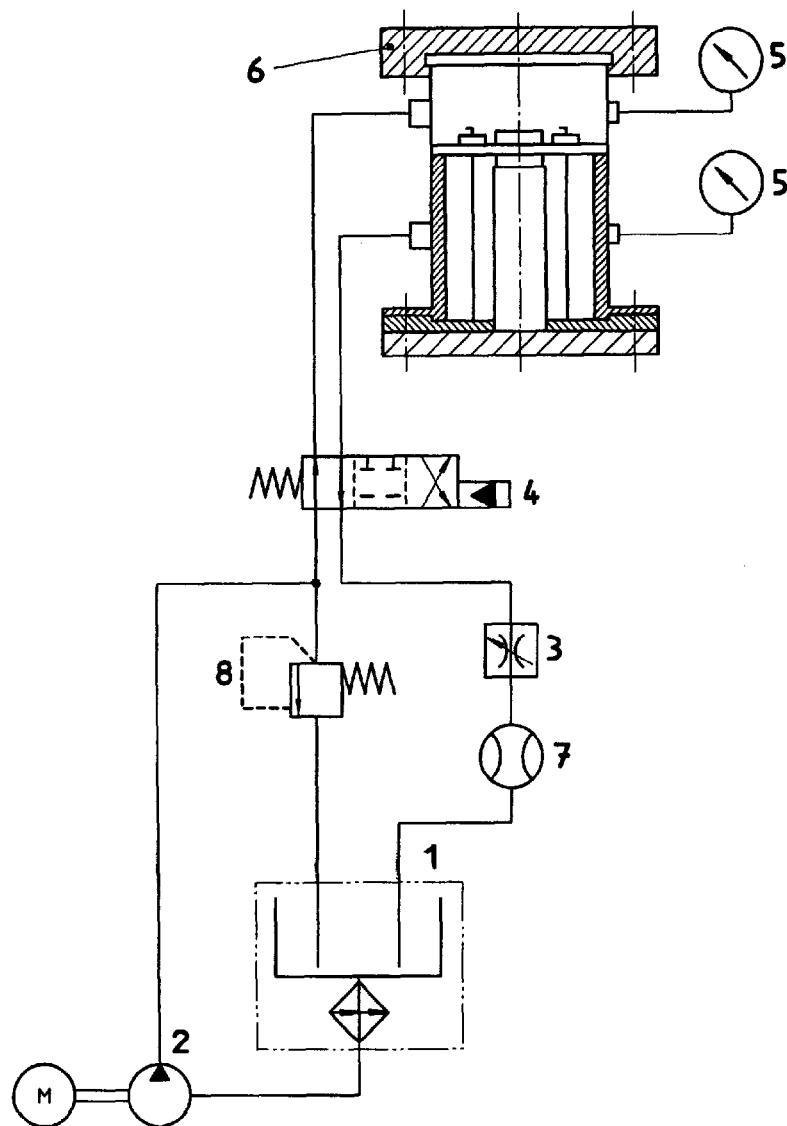

Key

- 1 Oil tank incorporating a thermostatically controlled heater
- 2 Motor pump unit
- 3 Flow-control valve
- 4 Hydraulic-control valve
- 5 Pressure gauges
- 6 Test box
- 7 Flow meter
- 8 Pressure-relief valve

Figure 5 — Test rig for mechanical stability to alternating direction of flow

11.3 Test procedure

11.3.1 Check the integrity of the filtering element in accordance with ISO 2942.

11.3.2 Mount the filtering element in the test box 6.

11.3.3 Ensure there is a proper seal between the test housing box and the filter element.

11.3.4 Mount the test box on the bench.

11.3.5 Purge the air from the test box.

11.3.6 Start the pump 2 and the oil heating device 1, and allow to operate at a flow rate equal to four times the flow rate specified by the supplier of the filter element, until the temperature is stabilized.

11.3.7 Programme the control mechanism of the hydraulic control valve 4 to carry out one cycle only in accordance with the graph shown in figure 6.

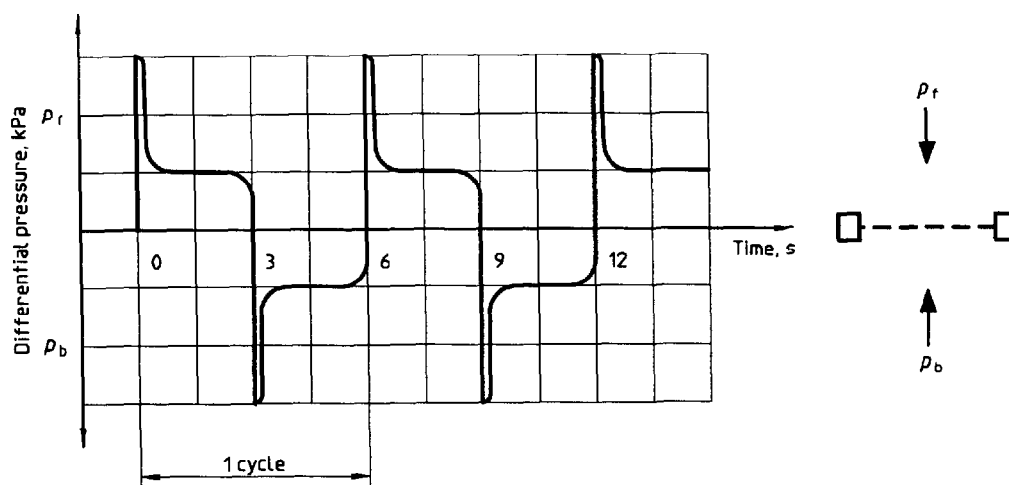

p_r differential pressure measured during the endurance test in the filtration direction.

p_b differential pressure measured during the endurance test in the back-flush direction.

Figure 6 — Cycles for endurance test

11.3.8 Subject the filter element to 10 000 cycles unless otherwise agreed between the supplier and the purchaser.

11.3.9 Dismantle the test box and remove the filter element.

11.4 Test results

11.4.1 Proceed with a visual and microscopic examination of the support(s) of the filtering media and of the filtering medium itself.

11.4.2 Check the integrity of the filtering element in accordance with ISO 2942.

11.5 Acceptance criteria

No deformation or tearing of the filtering element should be detectable.

Annex A
(informative)
Examples of graphs of differential pressure versus time

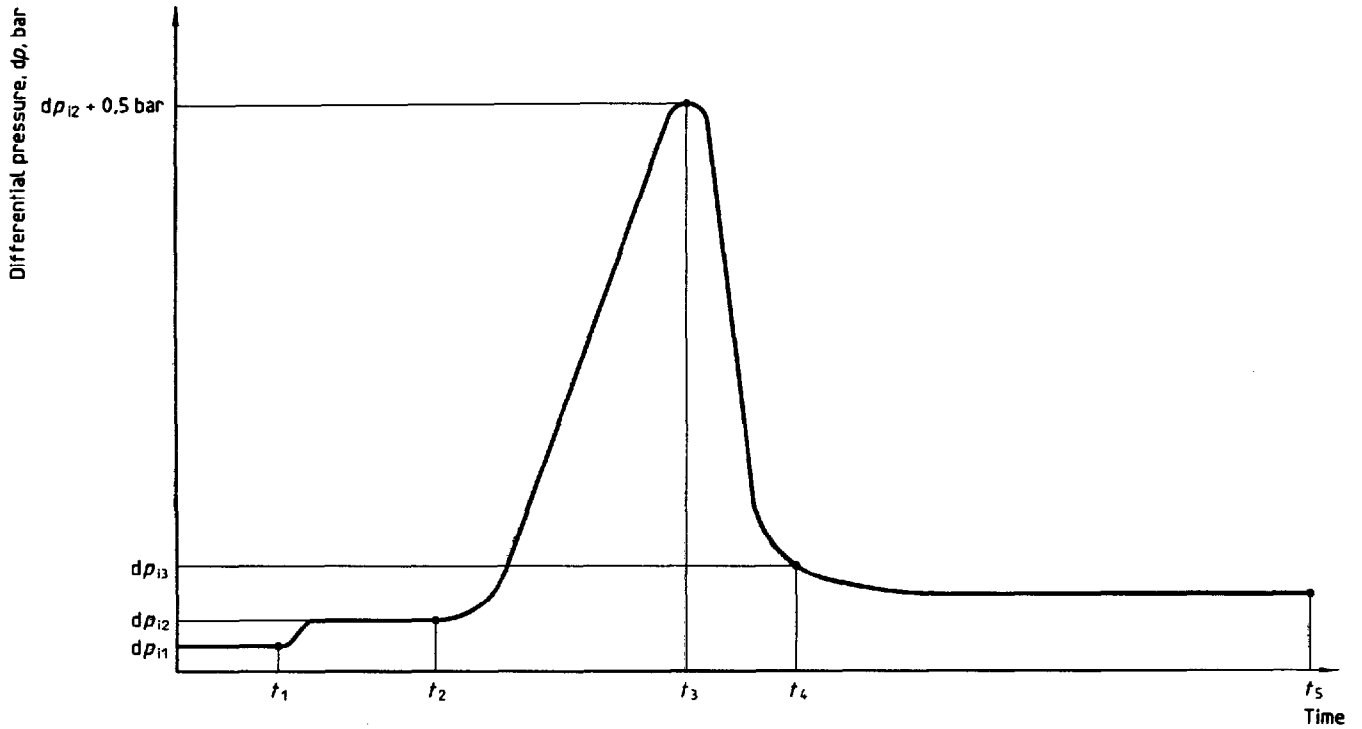

Figure A.1 — Main test

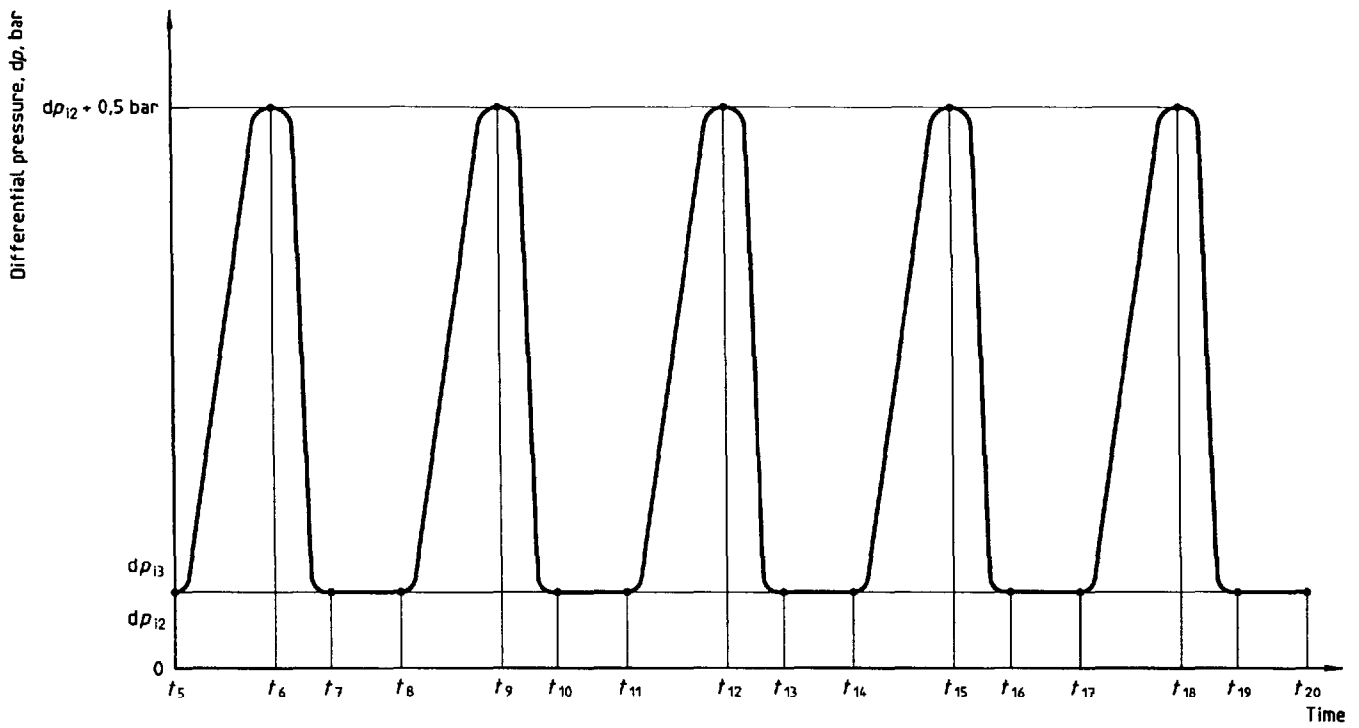

Figure A.2 — Additional tests (5 blocking and cleaning cycles)

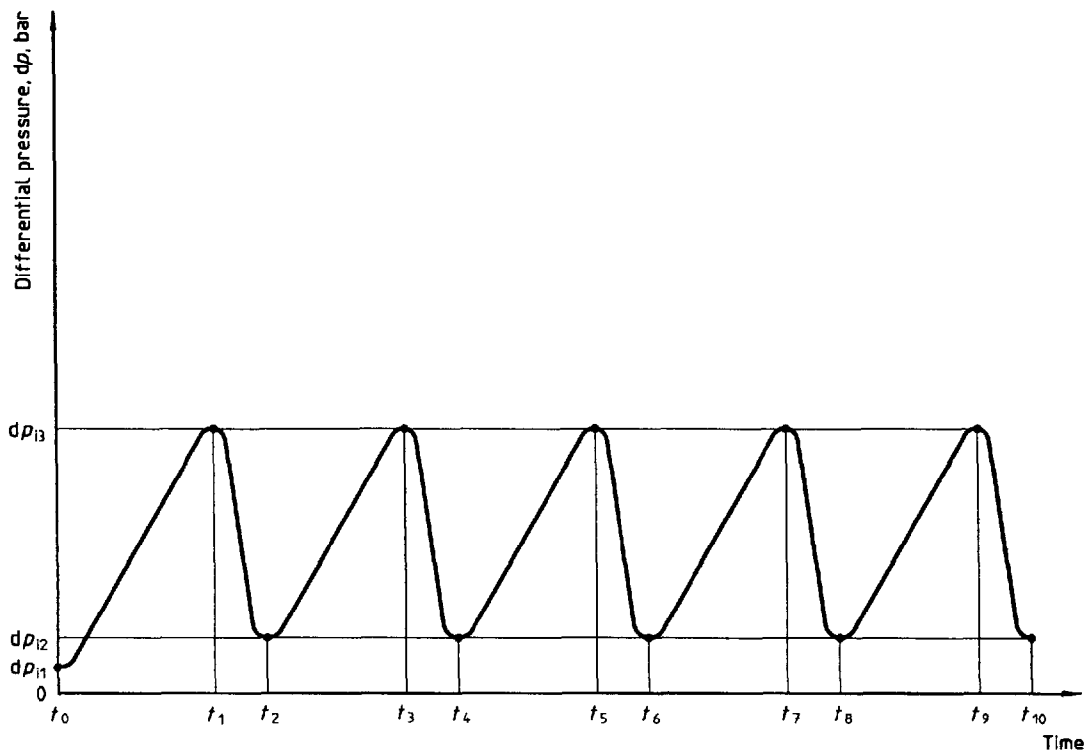

Figure A.3 — Filtration and cleaning tests

Annex B

(informative)

Bibliography

- [1] ISO 3448:1992, *Industrial liquid lubricants — ISO viscosity classification*.
- [2] ISO 4021:1992, *Hydraulic fluid power — Particulate contamination analysis — Extraction of fluid samples from lines of an operating system*.
- [3] ISO 4548-4:—⁵⁾, *Methods of test for full-flow lubricating oil filters for internal combustion engines — Part 4: Initial particle retention efficiency, life and cumulative efficiency (gravimetric method)*.
- [4] ISO 7967-6:1992, *Reciprocating internal combustion engines — Vocabulary of components and systems — Part 6: Lubricating systems*.

5) To be published.

ICS 27.020

Descriptors: internal combustion engines, lubrication systems, oil filters, tests, performance tests, test equipment.

Price based on 22 pages
