**Plastics piping systems for the supply
of gaseous fuels — Polyethylene
(PE) —**

**Part 3:
Fittings**

*Systèmes de canalisations en matières plastiques pour la distribution
de combustibles gazeux — Polyéthylène (PE) —*

Partie 3: Raccords





COPYRIGHT PROTECTED DOCUMENT

© ISO 2014

All rights reserved. Unless otherwise specified, no part of this publication may be reproduced or utilized otherwise in any form or by any means, electronic or mechanical, including photocopying, or posting on the internet or an intranet, without prior written permission. Permission can be requested from either ISO at the address below or ISO's member body in the country of the requester.

ISO copyright office
Case postale 56 • CH-1211 Geneva 20
Tel. + 41 22 749 01 11
Fax + 41 22 749 09 47
E-mail copyright@iso.org
Web www.iso.org

Published in Switzerland

Contents

	Page
Foreword	iv
Introduction	v
1 Scope	1
2 Normative references	1
3 Terms and definitions, symbols, and abbreviations	3
4 Materials	4
4.1 PE compound.....	4
4.2 Material for non-polyethylene parts.....	4
5 General characteristics	5
5.1 Appearance.....	5
5.2 Colour.....	5
5.3 Design.....	5
5.4 Appearance of factory made joints.....	5
5.5 Electrical characteristics for electrofusion fittings.....	5
6 Geometrical characteristics	6
6.1 Measurement of dimensions.....	6
6.2 Dimensions of electrofusion socket fittings.....	6
6.3 Dimensions of electrofusion saddle fittings.....	8
6.4 Dimensions of spigot end fittings.....	9
6.5 Dimensions of socket fusion fittings.....	12
6.6 Dimensions of mechanical fittings.....	12
7 Mechanical characteristics	12
7.1 General.....	12
7.2 Requirements.....	13
7.3 Performance requirements.....	13
7.4 Modifications of the fitting.....	13
8 Physical characteristics	16
8.1 Conditioning.....	16
8.2 Requirements.....	16
9 Performance requirements	17
10 Technical file	17
11 Marking	18
11.1 General.....	18
11.2 Minimum required marking of fittings.....	18
11.3 Additional marking.....	19
11.4 Fusion system recognition.....	19
12 Delivery conditions	19
Annex A (normative) Socket fusion fittings	20
Annex B (informative) Examples of typical terminal connection for electrofusion fittings	22
Annex C (normative) Short-term pressure test method	25
Annex D (normative) Tensile test for fitting/pipe assemblies	27
Annex E (informative) Formulae for calculating the equivalent dimensions of non-metric electrofusion socket fitting series	29
Bibliography	31

Foreword

ISO (the International Organization for Standardization) is a worldwide federation of national standards bodies (ISO member bodies). The work of preparing International Standards is normally carried out through ISO technical committees. Each member body interested in a subject for which a technical committee has been established has the right to be represented on that committee. International organizations, governmental and non-governmental, in liaison with ISO, also take part in the work. ISO collaborates closely with the International Electrotechnical Commission (IEC) on all matters of electrotechnical standardization.

The procedures used to develop this document and those intended for its further maintenance are described in the ISO/IEC Directives, Part 1. In particular the different approval criteria needed for the different types of ISO documents should be noted. This document was drafted in accordance with the editorial rules of the ISO/IEC Directives, Part 2 (see www.iso.org/directives).

Attention is drawn to the possibility that some of the elements of this document may be the subject of patent rights. ISO shall not be held responsible for identifying any or all such patent rights. Details of any patent rights identified during the development of the document will be in the Introduction and/or on the ISO list of patent declarations received (see www.iso.org/patents).

Any trade name used in this document is information given for the convenience of users and does not constitute an endorsement.

For an explanation on the meaning of ISO specific terms and expressions related to conformity assessment, as well as information about ISO's adherence to the WTO principles in the Technical Barriers to Trade (TBT) see the following URL: Foreword - Supplementary information

The committee responsible for this document is ISO/TC 138, *Plastics pipes, fittings and valves for the transport of fluids*, Subcommittee SC 4, *Plastics pipes and fittings for the supply of gaseous fuels*.

This first edition of ISO 4437-3 together with the first editions of ISO 4437-1, ISO 4437-2 and ISO 4437-5 cancel and replace ISO 4437:2007, ISO 8085-1:2001, ISO 8085-2:2001 and ISO 8085-3:2001, of which they constitute a technical revision.

ISO 4437 consists of the following parts, under the general title *Plastics piping systems for the supply of gaseous fuels — Polyethylene (PE)*:

- *Part 1: General*
- *Part 2: Pipes*
- *Part 3: Fittings*
- *Part 4: Valves*
- *Part 5: Fitness for purpose of the system*

Introduction

This part of ISO 4437 specifies the requirements for a piping system and its components made from polyethylene (PE), and which is intended to be used for the supply of gaseous fuels.

Requirements and test methods for material and components, other than fittings, are specified in ISO 4437-1, ISO 4437-2, and ISO 4437-4.

Characteristics for fitness for purpose of the system are covered in ISO 4437-5.

Recommended practice for installation is given in ISO/TS 10839.[\[1\]](#)

This part of ISO 4437 covers the characteristics of fittings.

Plastics piping systems for the supply of gaseous fuels — Polyethylene (PE) —

Part 3: Fittings

1 Scope

This part of ISO 4437 specifies the characteristics of fusion fittings made from polyethylene (PE) as well as of mechanical fittings for piping systems in the field of the supply of gaseous fuels.

It also specifies the test parameters for the test methods referred to in this part of ISO 4437.

In conjunction with ISO 4437-1, ISO 4437-2, ISO 4437-4, and ISO 4437-5, it is applicable to PE pipes, fittings and valves, their joints, and joints with components of PE and other materials intended to be used under the following conditions:

- a) the maximum operating pressure (MOP) is based on the design stress, determined from the compound minimum required strength (MRS) divided by the *C* factor, and taking into account rapid crack propagation (RCP) requirements;
- b) a temperature of 20 °C as reference temperature for the design basis.

NOTE 1 For other operating temperatures, derating coefficients are given in ISO 4437-5:2014.

NOTE 2 It is the responsibility of the purchaser or specifier to make the appropriate selections from these aspects, taking into account their particular requirements and any relevant national regulations and installation practices or codes.

This part of ISO 4437 is applicable for fittings of the following types:

- electrofusion socket fittings;
- electrofusion saddle fittings;
- spigot end fittings (for butt fusion using heated tools and electrofusion socket fusion);
- socket fusion fittings;
- mechanical fittings.

The fittings can for example be in the form of couplers, saddles, equal and reduced tees, reducers, elbows, bends, or end caps.

NOTE 3 Fabricated fittings are normally not used for gas applications except for larger dimensions or in the absence of other solutions. Guidance can be found in ISO 4427-3:2007, Annex B.^[2]

2 Normative references

The following documents, in whole or in part, are normatively referenced in this document and are indispensable for its application. For dated references, only the edition cited applies. For undated references, the latest edition of the referenced document (including any amendments) applies.

ISO 7-1, *Pipe threads where pressure-tight joints are made on the threads — Part 1: Dimensions, tolerances and designation*

ISO 4437-3:2014(E)

ISO 228-1, *Pipe threads where pressure-tight joints are not made on the threads — Part 1: Dimensions, tolerances and designation*

ISO 1133-1, *Plastics — Determination of the melt mass-flow rate (MFR) and the melt volume-flow rate (MVR) of thermoplastics — Part 1: Standard method*

ISO 1167-1:2006, *Thermoplastics pipes, fittings and assemblies for the conveyance of fluids — Determination of the resistance to internal pressure — Part 1: General method*

ISO 1167-4, *Thermoplastics pipes, fittings and assemblies for the conveyance of fluids — Determination of the resistance to internal pressure — Part 4: Preparation of assemblies*

ISO 3126, *Plastics piping systems — Plastics components — Determination of dimensions*

ISO 4437-1:2014, *Plastics piping systems for the supply of gaseous fuels — Polyethylene (PE) — Part 1: General*

ISO 4437-2:2014, *Plastics piping systems for the supply of gaseous fuels — Polyethylene (PE) — Part 2: Pipes*

ISO 4437-5:2014, *Plastics piping systems for the supply of gaseous fuels — Polyethylene (PE) — Part 5: Fitness for purpose of the system*

ISO 10838-1 ¹⁾, *Mechanical fittings for polyethylene piping systems for the supply of gaseous fuels — Part 1: Metal fittings for pipes of nominal outside diameter less than or equal to 63 mm*

ISO 10838-2 ¹⁾, *Mechanical fittings for polyethylene piping systems for the supply of gaseous fuels — Part 2: Metal fittings for pipes of nominal outside diameter greater than 63 mm*

ISO 10838-3 ¹⁾, *Mechanical fittings for polyethylene piping systems for the supply of gaseous fuels — Part 3: Thermoplastics fittings for pipes of nominal outside diameter less than or equal to 63 mm*

ISO 11357-6, *Plastics — Differential scanning calorimetry (DSC) — Part 6: Determination of oxidation induction time (isothermal OIT) and oxidation induction temperature (dynamic OIT)*

ISO 12176-4, *Plastics pipes and fittings — Equipment for fusion jointing polyethylene systems — Part 4: Traceability coding*

ISO 13950, *Plastics pipes and fittings — Automatic recognition systems for electrofusion joints*

ISO 13951, *Plastics piping systems — Test method for the resistance of polyolefin pipe/pipe or pipe/fitting assemblies to tensile loading*

ISO 13953, *Polyethylene (PE) pipes and fittings — Determination of the tensile strength and failure mode of test pieces from a butt-fused joint*

ISO 13954, *Plastics pipes and fittings — Peel decohesion test for polyethylene (PE) electrofusion assemblies of nominal outside diameter greater than or equal to 90 mm*

ISO 13955, *Plastics pipes and fittings — Crushing decohesion test for polyethylene (PE) electrofusion assemblies*

ISO 13956, *Plastics pipes and fittings — Decohesion test of polyethylene (PE) saddle fusion joints — Evaluation of ductility of fusion joint interface by tear test*

ISO 13957, *Plastics pipes and fittings — Polyethylene (PE) tapping tees — Test method for impact resistance*

ISO 16010, *Elastomeric seals — Material requirements for seals used in pipes and fittings carrying gaseous fuels and hydrocarbon fluids*

ISO 21751, *Plastics pipes and fittings — Decohesion test of electrofusion assemblies — Strip-bend test*

1) These International Standards are under revision and will be replaced by ISO 17885.

EN 12117, *Plastics piping systems – Fittings, valves and ancillaries – Determination of gaseous flow rate/pressure drop relationships*

3 Terms and definitions, symbols, and abbreviations

For the purposes of this document, the terms and definitions, symbols, and abbreviations given in ISO 4437-1:2014 and the following apply.

3.1

electrofusion socket fitting

polyethylene (PE) fitting which contains one or more integral heating elements that are capable of transforming electrical energy into heat to realize a fusion joint with a spigot end or a pipe

3.2

electrofusion saddle fitting

polyethylene (PE) fitting which contains one or more integral heating elements that are capable of transforming electrical energy into heat to realize a fusion joint onto a pipe

3.2.1

electrofusion tapping tee

electrofusion saddle fitting (top loading or wrap round) which contains an integral cutter to cut through the wall of the main pipe, which remains in the body of the tapping tee after installation

3.2.2

electrofusion branch saddle

electrofusion saddle fitting (top loading or wrap round) which requires an ancillary cutting tool for drilling a hole in the adjoining main pipe

3.3

spigot end fitting

polyethylene (PE) fitting where the outside diameter of the spigot end is equal to the nominal outside diameter, d_n , of the corresponding pipe

3.4

socket fusion fitting

polyethylene (PE) fitting heated by a purpose-made heating tool to realize a fusion joint with a spigot end or a pipe

3.5

mechanical fitting

fitting that generally includes a compression part to provide pressure integrity, leak tightness, and resistance to end loads for assembling polyethylene (PE) pipe to another PE pipe or any other element of the piping system

Note 1 to entry: A pipe-supporting sleeve providing a permanent support for a polyethylene (PE) pipe to prevent creep in the pipe wall under radial compressive forces is applicable. The metallic parts of the fitting can be assembled to metallic pipes by screw-threads, compression joints, and welded or flanged connections, including PE flanges. In some cases, the supporting sleeve at the same time constitutes a grip ring.

Note 2 to entry: The fitting can allow either a dismountable or permanently assembled joint.

Note 3 to entry: The mechanical fitting can be supplied for field assembly or pre-assembled by the manufacturer.

3.6

voltage regulation

control of energy supplied during the fusion process of an electrofusion fitting by means of the voltage parameter

3.7 intensity regulation
control of energy supplied during the fusion process of an electrofusion fitting by means of the current parameter

4 Materials

4.1 PE compound

The PE compound from which the fittings are made shall conform to ISO 4437-1:2014.

The stress bearing parts shall only be made from virgin material conforming to ISO 4437-1:2014.

4.2 Material for non-polyethylene parts

4.2.1 General

All components shall conform to the relevant International Standards. Alternative standards can be applied in cases where International Standards do not exist. In all cases, fitness for purpose of the system of the components shall be demonstrated.

The materials and the constituent elements used in making the fitting (including elastomers and any metal parts as can be used) shall be as resistant to the external and internal environments as the other elements of the piping system, and shall have an expected lifetime under the following conditions at least equal to that of the PE pipes conforming to ISO 4437-2:2014 with which they are intended to be used:

- a) during storage;
- b) under the effect of the gas conveyed therein;
- c) with respect to the service environment and operating conditions.

The requirements for the level of material performance of non-polyethylene parts shall be at least as stringent as that of the PE compound for the piping system. Rework materials shall not be used for stress bearing polymeric parts.

Other materials used in fittings in contact with the PE pipe shall not adversely affect pipe performance or initiate stress cracking.

NOTE [4.2](#) does not apply to non-stress bearing fitting parts.

4.2.2 Metal parts

All metal parts susceptible to corrosion shall be adequately protected, providing this is necessary for the durability and function of the system.

When dissimilar metallic materials are used, which can be in contact with moisture, steps shall be taken to avoid the possibility of galvanic corrosion.

4.2.3 Elastomers

Elastometric seals shall conform to ISO 16010.

Other sealing materials are permitted if suitable for gas service.

4.2.4 Other materials

Greases or lubricants shall not exude onto fusion areas and shall not affect the long-term performance of fitting materials.

5 General characteristics

5.1 Appearance

When viewed without magnification, the internal and external surfaces of fittings shall be smooth and clean, and shall have no scoring, cavities, and other surface defects to an extent that would prevent conformity to this part of ISO 4437.

No component of the fitting shall show any signs of damage, scratches, pitting, bubbles, blisters, inclusions, or cracks to an extent that would prevent conformity of the fittings to the requirements of this part of ISO 4437.

5.2 Colour

The colour of the PE parts of the fitting shall be either black, yellow, or orange.

5.3 Design

The design of the fitting shall be such that, when assembling the fitting onto the pipe or other component, electrical coils and/or seals are not displaced.

5.4 Appearance of factory made joints

The internal and external surfaces of the pipe and fitting after fusion jointing, examined visually without magnification, shall be free from melt exudation outside the confines of the fitting, apart from that which can be declared acceptable by the fitting manufacturer or used deliberately as a fusion marker.

Any melt exudation shall not cause wire movement in electrofusion fittings such that it leads to short-circuiting when jointed in accordance with the manufacturer's instructions. There shall be no excessive creasing of the internal surfaces of the adjoining pipes.

5.5 Electrical characteristics for electrofusion fittings

The electrical protection that shall be provided by the fusion process depends on the voltage and the current used and on the characteristics of the electricity power source.

For voltages greater than 25 V, direct human contact with energized parts shall not be possible when the fitting is in the fusion cycle during assembly in accordance with the instructions of the manufacturers of the fittings and of the assembly equipment, as applicable.

NOTE 1 The fitting during the fusion process is part of an electrical system as defined in EN 60335-1,^[3] HD 60364-1,^[4] and IEC 60449.^[5]

The tolerance on the electrical resistance of the fitting at 23 °C shall be stated by the manufacturer. The resistance shall be between nominal resistance (−10 %) and nominal resistance (+10 %) + 0,1 Ω.

NOTE 2 0,1 Ω is the assumed value of the contact resistance.

The surface finish of the terminal pins shall allow a minimum contact resistance in order to satisfy the resistance tolerance requirements.

NOTE 3 See [Annex B](#) for the examples of typical electrofusion terminal connections.

6 Geometrical characteristics

6.1 Measurement of dimensions

Dimensions shall be measured in accordance with ISO 3126 at $(23 \pm 2) ^\circ\text{C}$, after being conditioned for at least 4 h. The measurement shall not be made less than 24 h after manufacture.

Indirect measurement at the stage of production is allowed at shorter time periods, provided that evidence is shown of correlation.

6.2 Dimensions of electrofusion socket fittings

6.2.1 Diameters and lengths of electrofusion sockets

When measured in accordance with 6.1, the diameters and lengths of electrofusion sockets (see Figure 1) shall conform to Table 1.

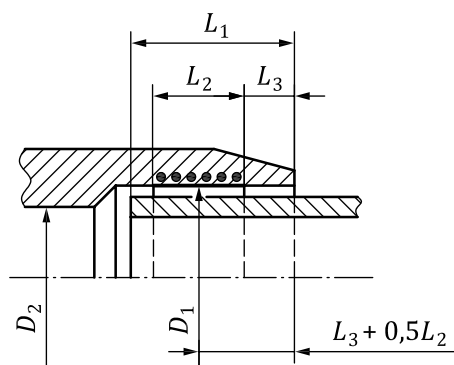

Key

- D_1 “mean inside diameter in the fusion zone” measured in a plane parallel to the plane of the mouth at a distance of $L_3 + 0,5L_2$
- D_2 bore, which is the minimum diameter of the flow channel through the body of the fitting where $D_2 \geq (d_n - 2e_{\min})$
- L_1 “design penetration depth” of the pipe or male end of a spigot fitting (in case of a coupling without stop, it is not greater than half the total length of the fitting)
- L_2 heated length within a socket as declared by the manufacturer to be the nominal length of the fusion zone
- L_3 distance between the mouth of the fitting and the start of the fusion zone as declared by the manufacturer to be the nominal unheated entrance length of the fitting where L_3 shall be ≥ 5 mm

Figure 1 — Dimensions of electrofusion socket fittings

Table 1 — Dimensions of electrofusion socket fittings

Dimensions in millimetres

Nominal diameter d_n	Depth of penetration			Fusion zone $L_{2,min}$
	$L_{1,min}$		$L_{1,max}$	
	Intensity regulation	Voltage regulation		
16	20	25	41	10
20	20	25	41	10
25	20	25	41	10
32	20	25	44	10
40	20	25	49	10
50	20	28	55	10
63	23	31	63	11
75	25	35	70	12
90	28	40	79	13
110	32	53	82	15
125	35	58	87	16
140	38	62	92	18
160	42	68	98	20
180	46	74	105	21
200	50	80	112	23
225	55	88	120	26
250	73	95	129	33
280	81	104	139	35
315	89	115	150	39
355	99	127	164	42
400	110	140	179	47
450	122	155	195	51
500	135	170	212	56
560	147	188	235	61
630	161	209	255	67

The mean inside diameter of the fitting in the middle of the fusion zone (see D_1 in [Figure 1](#)) shall be not less than d_n .

The manufacturer shall declare the actual minimum and maximum values of D_1 and determine their suitability for joint assembly and fitness for purpose of the system testing in accordance with ISO 4437-5:2014.

In the case of a fitting having sockets of differing nominal diameters, each one shall conform to the requirements for the nominal diameter of the corresponding component.

NOTE Information for non-metric series is given in [Annex E](#).

6.2.2 Wall thicknesses

In order to prevent stress concentrations, any changes in wall thickness of the fitting body shall be gradual.

- a) The wall thickness of the body of the fitting at any point, E , shall be greater than or equal to e_{\min} for the corresponding pipe at any part of the fitting located at a distance beyond a maximum of $2L_1/3$ from all entrance faces, if the fitting and the corresponding pipe are made from a polyethylene having the same MRS.

If the fitting is produced from a polyethylene having an MRS that is different from that of the corresponding pipe, the relationship between the wall thickness of the fitting, E , and the pipe, e_{\min} , shall be in accordance with [Table 2](#).

Table 2 — Relationship between fitting wall thickness, E , and pipe wall thickness, e_{\min}

Pipe and fitting material		Relationship
Pipe	Fitting	
PE 80	PE 100	$E \geq 0,8e_{\min}$
PE 100	PE 80	$E \geq 1,25e_{\min}$

- b) In the case of a wall thickness design different from that according to a), fittings and associated fusion joints shall additionally meet the performance requirements given in [7.3](#).

6.2.3 Out-of-roundness of the bore of a fitting (at any point)

When a fitting leaves the site of the manufacturer, the out-of-roundness of the bore of a fitting at any point shall not exceed $0,015 d_n$.

6.2.4 Spigots

For fittings that contain spigot outlets (e.g. electrofusion equal tee with a spigotted branch), the dimensions of the spigot shall conform to [6.4](#).

6.2.5 Other dimensions

The dimensional characteristics appropriate to each manufacturer, such as the overall dimensions or mounting dimensions, shall be specified in a technical file.

In the case of a coupling without an internal stop or with a removable centre register, the geometry of the fitting shall allow the penetration of the pipe through the fitting.

6.3 Dimensions of electrofusion saddle fittings

Outlets from tapping tees and branch saddles shall have spigots conforming to [6.4](#) or an electrofusion socket conforming to [6.2](#).

The manufacturer shall specify the overall dimensions of the fitting in a technical file. These dimensions shall include the maximum height of the saddle, H , and for tapping tees the height of the service pipe, H_1 or H_2 (see [Figure 2](#)).

NOTE For technical and design reasons, the minimum bore diameter D_2 could be different from the one of spigot fittings as given in [6.4](#).

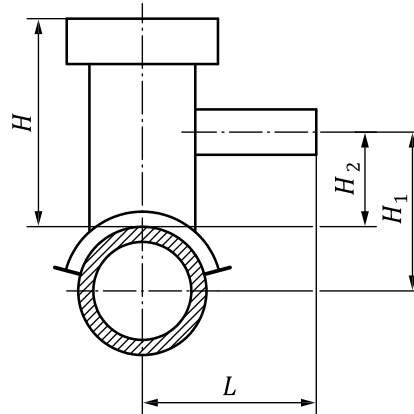
**Key**

- H height of the saddle, which comprises the distance from the top of the main pipe to the top of the tapping tee or saddle
- H_1 height of service pipe, which comprises the distance from the axis of the main pipe to the axis of the service pipe
- H_2 height of service pipe, which comprises the distance from the top of the main pipe to the axis of the service pipe
- L width of the tapping tee, which comprises the distance between the axis of the pipe and the plane of the mouth of the service tee

Figure 2 — Dimensions of electrofusion saddle fittings

6.4 Dimensions of spigot end fittings

6.4.1 Diameters and lengths

The dimensions of spigot end fittings (see [Figure 3](#)) shall conform to the values given in [Table 3](#).

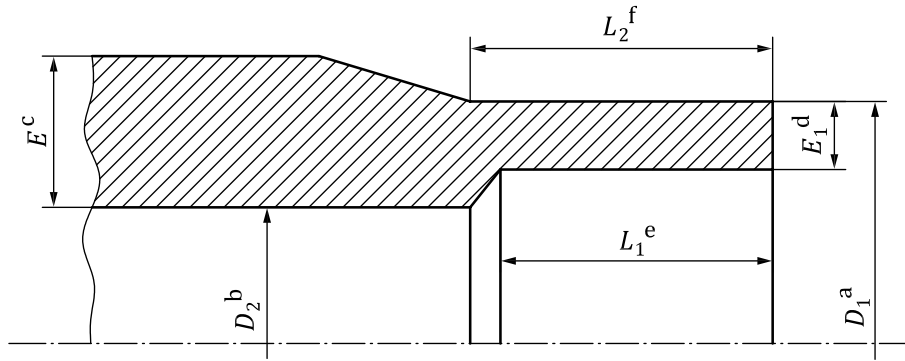

Key

- D_1 mean outside diameter of fusion end piece
- D_2 bore comprising minimum diameter of flow channel through body of fitting
- E body wall thickness of fitting
- E_1 fusion face wall thickness
- L_1 cut-back length of fusion end piece
- L_2 tubular length of fusion end piece
- ^a D_1 is measured in any plane parallel to the plane of the entrance face at a distance not greater than L_2 (tubular length) from the plane of the entrance face.
- ^b The measurement of this diameter does not include the fusion pad (if present).
- ^c It comprises the thickness measured at any point of the wall of the fitting.
- ^d It is measured at any point at a maximum distance of L_1 (cut-back length) from the entrance face and shall be equal to the pipe wall thickness and tolerance to which it is intended to be butt-fused, as specified in ISO 4437-2:2014, Table 2. E_1 for small dimensions is at least 3 mm.
- ^e It comprises the initial depth of the spigot end necessary for butt fusion or reweld and can be obtained by joining a length of pipe to the spigot end of the fitting, provided that the wall thickness of the pipe is equal to E_1 for its entire length.
- ^f It comprises the initial length of the fusion end piece and shall allow the following (in any combination): the use of clamps required in the case of butt fusion; assembly with an electrofusion fitting; the use of a mechanical scraper.

Figure 3 — Dimensions of spigot end fittings

Table 3 — Diameters and lengths of spigot end fittings

Dimensions in millimetres

Nominal diameter d_n	Mean outside diameter of fusion end		Out-of-roundness max.	Minimum bore $D_{2,min}$	Cut-back length $L_{1,min}$	Tubular length ^b $L_{2,min}$
	$D_{1,min}$	$D_{1,max}^a$				
16	16	16,3	0,3	9	25	41
20	20	20,3	0,3	13	25	41
25	25	25,3	0,4	18	25	41
32	32	32,3	0,5	25	25	44
40	40	40,4	0,6	31	25	49
50	50	50,4	0,8	39	25	55
63	63	63,4	0,9	49	25	63
75	75	75,5	1,2	59	25	70
90	90	90,6	1,4	71	28	79
110	110	110,7	1,7	87	32	82
125	125	125,8	1,9	99	35	87
140	140	140,9	2,1	111	38	92
160	160	161,0	2,4	127	42	98
180	180	181,1	2,7	143	46	105
200	200	201,2	3,0	159	50	112
225	225	226,4	3,4	179	55	120
250	250	251,5	3,8	199	60	129
280	280	281,7	4,2	223	75	139
315	315	316,9	4,8	251	75	150
355	355	357,2	5,4	283	75	164
400	400	402,4	6,0	319	75	179
450	450	452,7	6,8	359	100	195
500	500	503,0	7,5	399	100	212
560	560	563,4	8,4	447	100	235
630	630	633,8	9,5	503	100	255

^a The tolerance grades conform to ISO 11922-1:1997,^[6] Grade B.

^b Spigot end fittings can be delivered with shorter tubular length L_2 for factory assemblies or in association with appropriate electrofusion fittings.

6.4.2 Wall thickness of the fusion end

The wall thickness of the fusion end, E_1 , shall be at least equal to the minimum wall thickness of the pipe, except between the plane of the entrance face and a plane parallel to it, located at a distance not greater than $(0,01 d_e + 1 \text{ mm})$, where a thickness reduction, for example a chamfered edge, is permitted, E_1 for small dimensions is at least 2,3 mm or 3 mm depending on the pipe series.

The permissible tolerance of the wall thickness, E_1 , at any point shall conform to those of the nominal wall thicknesses given in ISO 4437-2:2014.

6.4.3 Wall thickness of the fitting body

The wall thickness, E , of the fitting body measured at any point, shall be at least equal to the nominal wall thickness, e_n , of the pipe.

Any changes in wall thickness inside the body of the fitting shall be gradual in order to prevent stress concentrations.

6.4.4 Other dimensions

The dimensional characteristics appropriate to each manufacturer, such as overall dimensions or clamping requirements, shall be stated in a technical file.

6.5 Dimensions of socket fusion fittings

For the description and dimensions of these types of fittings, see [Annex A](#).

6.6 Dimensions of mechanical fittings

6.6.1 General

The dimensions of mechanical fittings shall conform to ISO 10838-1, ISO 10838-2, or ISO 10838-3, as applicable, and shall be capable of assembly on to PE pipe conforming to ISO 4437-2:2014.

NOTE The ISO 10838 series will be replaced by ISO 17885.

The fittings shall be designed and manufactured in such a way that they can be used buried or above ground. Pre-assembled mechanical fittings shall not be capable of being dismantled.

The fittings shall be designed to avoid twisting of the PE pipe during assembly.

The fittings shall include, if required, a means for anchoring an anti-shear sleeve.

The fittings shall not be assembled by thread cutting the PE pipe.

6.6.2 Mechanical fittings with polyethylene spigot ends

Polyethylene spigot ends shall conform to [6.4](#).

6.6.3 Mechanical fittings with polyethylene electrofusion sockets

Electrofusion sockets shall conform to [6.2](#).

6.6.4 Threads

Threads on metal ends shall conform to ISO 7-1 or ISO 228-1, as applicable.

7 Mechanical characteristics

7.1 General

Fittings shall be tested using pipes which conform to ISO 4437-2:2014.

Jointed pipe and fitting test pieces shall be assembled in accordance with the technical instructions of the manufacturer and take into account the extreme conditions of utilization described in ISO 4437-5:2014. The sample test assemblies shall take account of manufacturing and assembly tolerances.

7.2 Requirements

Unless otherwise specified by the applicable test method, the test pieces shall be conditioned at (23 ± 2) °C before testing in accordance with [Table 4](#).

When tested in accordance with the test methods as specified in [Table 4](#) using the indicated parameters, the fittings shall have mechanical characteristics conforming to the requirements given in [Table 4](#), as applicable to the following types of fitting:

- (A) electrofusion socket fitting and socket fusion fitting;
- (B) electrofusion saddle fitting;
- (C) spigot end fitting.

For mechanical fittings, the requirements of ISO 10838-1, ISO 10838-2, or ISO 10838-3 shall apply.

NOTE The ISO 10838 series are under revision and will be replaced by ISO 17885.

7.3 Performance requirements

Where [6.2.2 b\)](#) applies, electrofusion socket fittings shall additionally be in accordance with [Table 6](#).

7.4 Modifications of the fitting

In the event of modification of the fitting or jointing parameters, the manufacturer shall ensure that the joint conforms to the requirements given in this part of ISO 4437.

NOTE Guidance on assessment of conformity depending on the modification can be found in CEN/TS 1555-7[7]

Table 4 — Mechanical characteristics

Characteristic	Requirements	Test parameters		Test method	
		Parameter	Value		
Hydrostatic strength (20 °C, 100 h) ^d	No failure during test period of any test piece	End caps	Type A of ISO 1167-1:2006	ISO 1167-1:2006 and ISO 1167-4	
		Orientation	Free		
		Conditioning time	Shall conform to ISO 1167-1:2006		
		Number of test pieces ^a	3		
		Type of test	Water-in-water		
		Circumferential (hoop) stress in pipe ^b for:	PE 80		9,0 MPa
			PE 100		12,0 MPa
		Test period	100 h		
Test temperature	20 °C				
Hydrostatic strength (80 °C, 165 h) ^d	No failure during test period of any test piece ^c	End caps	Type A of ISO 1167-1:2006	ISO 1167-1:2006 and ISO 1167-4	
		Orientation	Free		
		Conditioning time	Shall conform to ISO 1167-1:2006		
		Number of test pieces ^a	3		
		Type of test	Water-in-water		
		Circumferential (hoop) stress in pipe ^b for:	PE 80		4,5 MPa
			PE 100		5,4 MPa
		Test period	165 h		
Test temperature	80 °C				
Hydrostatic strength (80 °C, 1 000 h) ^d	No failure during test period of any test piece	End caps	Type A of ISO 1167-1:2006	ISO 1167-1:2006 and ISO 1167-4	
		Orientation	Free		
		Conditioning time	Shall conform to ISO 1167-1:2006		
		Number of test pieces ^a	3		
		Type of test	Water-in-water		
		Circumferential (hoop) stress in pipe ^b for:	PE 80		4,0 MPa
			PE 100		5,0 MPa
		Test period	1 000 h		
Test temperature	80 °C				
Decohesive resistance (A) ^f	Length of initiation rupture $\leq L_2/3$ in brittle failure	Test temperature	23 °C	ISO 13954 ISO 13955	
		Number of test pieces ^a	Shall conform to ISO 13954 and ISO 13955		
Evaluation of ductility of fusion joint interface (B) ^{f g}	Surface of rupture $L_d \leq 50\%$ and $A_d \leq 25\%$, brittle failure	Test temperature	23 °C	ISO 13956	
		Number of test pieces ^a	Shall conform to ISO 13956		

Table 4 (continued)

Characteristic	Requirements	Test parameters		Test method
		Parameter	Value	
Tensile strength for butt fusion (C) ^e	Test to failure: ductile – pass brittle – fail	Test temperature	23°C	ISO 13953
		Number of test pieces ^a	Shall conform to ISO 13953	
Impact resistance (B)	No failure, no leakage	Test temperature	0 °C	ISO 13957
		Falling height	2 m	
		Mass of the striker	2,5 kg	
		Number of test pieces ^a	1	
Pressure drop (B)	Air flow rate (value indicated by the manufacturer)	Test medium	Air source	EN 12117
		Test pressure	25 mbar	
		Pressure drop:		
		for $d_n \leq 63$ mm	0,5 mbar	
		for $d_n > 63$ mm	0,1 mbar	
	Number of test pieces ^a	1		
<p>^a The number of test pieces given indicates the number required to establish a value for the characteristic described in Table 4. The number of test pieces required for factory production control and process control should be listed in the manufacturer’s quality plan. Guidance on assessment of conformity can be found in CEN/TS 1555-7.[Z]</p> <p>^b The test pressure shall be calculated using the design standard dimension ratio (SDR) of the fitting.</p> <p>^c Only brittle failures shall be taken into account. If a ductile failure occurs before 165 h, the test can be repeated at a lower stress. The stress and the associated minimum test period shall be selected from Table 5 or from a line based on the stress/time points given in Table 5.</p> <p>^d Alternatively, for $d_n > 450$ mm, the test can also be performed in air. In case of dispute, water-in-water test shall be used. For fitting type (B) $d_n > 450$ mm, alternative testing is allowed (e.g. pressurization through saddle outlet).</p> <p>^e Applicable to d_n 90 mm and above.</p> <p>^f Test sample can be mechanically reduced in wall thickness for testing purpose of large diameter fittings by keeping a minimum of 15 mm wall thickness of each component.</p> <p>^g Alternatively, for fittings type (B) $d_n > 450$ mm, this characteristic can be checked by the strip-bend test according to ISO 21751.</p>				

Table 5 — Circumferential (hoop) stress at 80 °C and associated minimum test period

PE 80		PE 100	
Stress MPa	Minimum test period h	Stress MPa	Minimum test period h
4,5	165	5,4	165
4,4	233	5,3	256
4,3	331	5,2	399
4,2	474	5,1	629
4,1	685	5,0	1 000
4,0	1 000	–	–

Table 6 — Performance requirements

Characteristics	Requirement	Test parameters		Test method
		Parameter	Value	
Short-term internal pressure resistance	Failure pressure shall be greater than pressure equivalent of $2 \times$ MRS calculated for thickest-walled pipe for which fitting has been designed	End caps	Type A of ISO 1167-1:2006	Annex C
		Orientation	Free	
		Conditioning time	12 h	
		Type of test	Water-in-water	
		Minimum pressure, eg:		
		PE 80 pipe, SDR 11	32 bar	
		PE 100 pipe, SDR 11	40 bar	
		Pressure increase rate	5 bar/min	
		Test temperature	20 °C	
Resistance to tensile load	No leakage or failure of the fusion joint after 25 % elongation of the pipe	Test temperature	23 °C	Annex D

NOTE 1 bar = 0,1 MPa = 10^5 Pa; 1 MPa = 1 N/mm².

8 Physical characteristics

8.1 Conditioning

Unless otherwise specified by the applicable test method, the test pieces shall be conditioned at (23 ± 2) °C before testing in accordance with [Table 7](#).

8.2 Requirements

When tested in accordance with the test methods as specified in [Table 7](#) using the indicated parameters, the fittings shall have physical characteristics conforming to the requirements given in [Table 7](#).

Table 7 — Physical characteristics

Characteristic	Requirements	Test parameters		Test method
		Parameter	Value	
Oxidation induction time (Thermal stability)	≥ 20 min	Test temperature	200 °C ^b	ISO 11357-6
		Number of test pieces ^a	3	
		Test environment	Oxygen	
		Specimen weight	15 mg ± 2 mg	
Melt mass-flow rate (MFR)	After processing maximum deviation of ± 20 % of the value measured on the batch used to manufacture the fitting	Loading mass	5 kg	ISO 1133-1
		Test temperature	190 °C	
		Time	10 min	
		Number of test pieces ^a	Shall conform to ISO 1133-1	

a The number of test pieces given indicates the number required to establish a value for the characteristic described in Table 7. The number of test pieces required for factory production control and process control should be listed in the manufacturer's quality plan. Guidance on assessment of conformity can be found in CEN/TS 1555-7.[7]

b Test can be carried out at 210 °C or 220 °C provided that there is a clear correlation to the results at 200 °C; in case of dispute, the reference temperature shall be 200 °C.

9 Performance requirements

When fittings conforming to this part of ISO 4437 are assembled to each other or to components conforming to other parts of ISO 4437, the joints shall conform to ISO 4437-5:2014.

10 Technical file

The manufacturer of the fittings shall ensure the availability of a technical description (generally confidential) containing all relevant data necessary to prove the conformity of the fittings to this part of ISO 4437. The file shall include all results of type-testing. It shall also include all data necessary to implement a traceability system where required.

The technical description of the manufacturer shall include the following information:

a) field of application:

- 1) pipe and fitting temperature limits;
- 2) pipe series or SDRs;
- 3) out-of-roundness (ovality);

NOTE 1 For large size electrofusion fittings, additional information regarding out of roundness for pipes can be provided by the manufacturer.

b) assembly instructions;

c) fusion instructions:

- 1) fusion parameters with limits;

d) data for saddles and tapping tees:

- 1) the means of attachment (tools and/or underclamp);
- 2) the need to maintain the underclamp in position in order to ensure the performance of the assembly.

Sample test assemblies should take account of manufacturing tolerances, assembly tolerances, and ambient temperature variations at which the fittings can be used.

NOTE 2 Recommended practices for installation of PE fittings are given in relevant national installation practices or codes, or in ISO/TS 10839.^[4]

11 Marking

11.1 General

11.1.1 Unless otherwise stated in [Table 8](#), the marking elements shall be printed or formed directly on the fitting in such a way that after storage, weathering, handling, and installation legibility is maintained during the use of the fitting.

NOTE The manufacturer is not responsible for marking being illegible, due to actions caused during installation and use such as painting, scratching, covering of the components, or using detergents, etc. on the components unless agreed or specified by the manufacturer.

11.1.2 Marking shall not initiate cracks or other types of defects which adversely influence the performance of the fitting.

11.1.3 If printing is used, the colour of the printed information shall differ from the basic colour of the fitting.

11.1.4 The size of the marking shall be such that it is legible without magnification.

11.1.5 There shall be no marking over the minimum spigot length of the fittings.

11.2 Minimum required marking of fittings

The minimum required marking shall conform to [Table 8](#).

Table 8 — Minimum required marking

Aspects	Mark or symbol
Reference to this International Standard ^a	ISO 4437
Manufacturer's name and/or trademark	Name or symbol
Nominal outside diameter(s) of pipe, d_n	e.g. 110
Material and designation	e.g. PE 100
Design application series (i.e. design SDR)	e.g. SDR 11
Applicable SDR fusion range of pipe ^a	e.g. SDR 11 – SDR 26
Manufacturer's information	^c
Intended use ^{a b}	Gas
^a This information can be printed on a label associated with the fitting or on an individual bag. ^b Information on abbreviations can be found in national rules. ^c For providing traceability, the following details shall be given: — the production period, year and month, in figures or in code; — a name or code for the production site if the manufacturer is producing the same product at different sites.	

11.3 Additional marking

Additional information relative to the fusion conditions (e.g. fusion and cooling times) and to the assembly torque, only for mechanical fittings, could appear on a label, which can be attached to a fitting or can be separated from the fitting.

If traceability codes are provided, these shall be in accordance with ISO 12176-4.

11.4 Fusion system recognition

Fusion fittings should have a system, either numerical, electromechanical, or self-regulatory as described in ISO 13950, for recognizing the fusion parameters to facilitate the fusion process.

When automatic recognitions systems for electrofusion fittings are used, they shall be in accordance with ISO 13950.

12 Delivery conditions

The fittings shall be packaged in bulk or individually protected when necessary in order to prevent deterioration. Whenever possible, they shall be placed in individual bags, in cardboard boxes, or cartons.

Constituents of fitting packaging shall not create contamination which can prevent normal jointing.

The cartons and/or individual bags shall bear at least one label with the manufacturer's name, type and dimensions of the part, number of units in the box, and any special storage conditions and storage time limits if any.

It is recommended that fittings be stored in their original packing until ready for installation.

Annex A (normative)

Socket fusion fittings

When applicable, the dimensions of socket fusion fittings shall conform to [Tables A.1](#) and [A.2](#). The diameter at the root shall not be greater than the diameter at the mouth.

Table A.1 — Socket dimensions for nominal sizes 16 to 63 inclusive

Dimensions in millimetres

Nom. size DN/ OD	Nominal inside diam. of socket	Mean inside diameter of socket				Out-of- round- ness	Min. bore	Socket refer- ence length	Heated socket length		Penetration of pipe into socket	
		Mouth		Root					(L - 2,5)	(L)	(L - 3,5)	(L - 1)
		$D_{1,min}$	$D_{1,max}$	$D_{2,min}$	$D_{2,max}$				max.	D_3	L_{min}	$L_{2,min}$
16	16	15,2	15,5	15,1	15,4	0,4	9	13,3	10,8	13,3	9,8	12,3
20	20	19,2	19,5	19,0	19,3	0,4	13	14,5	12,0	14,5	11,0	13,5
25	25	24,1	24,5	23,9	24,3	0,4	18	16,0	13,5	16,0	12,5	15,0
32	32	31,1	31,5	30,9	31,3	0,5	25	18,1	15,6	18,1	14,6	17,1
40	40	39,0	39,4	38,8	39,2	0,5	31	20,5	18,0	20,5	17,0	19,5
50	50	48,9	49,4	48,7	49,2	0,6	39	23,5	21,0	23,5	20,0	22,5
63	63	62,0 ^a	62,4 ^a	61,6	62,1	0,6	49	27,4	24,9	27,4	23,9	26,4

NOTE Maximum $L_2 = L$ mm and the minimum L_2 is calculated from $L - 2,5$ mm and the maximum $L_3 = L - 1$ mm and the minimum $L_3 = L - 3,5$ mm.

^a Where rerounding clamps are used, the maximum diameter of 62,4 mm can be increased by 0,1 mm to 62,5 mm. Conversely, where a peeling technique is used, the minimum diameter of 62,0 mm can be reduced by 0,1 mm to 61,9 mm.

Table A.2 — Socket dimensions for fittings nominal sizes 75 to 125 inclusive

Dimensions in millimetres

Nom. size DN/ OD	Mean outside diameter of pipe		Nominal inside diam. of socket	Mean inside diameter of socket				Out-of- round- ness	Min. bore	Socket ref. length	Heated socket length		Penetration of pipe into socket	
				Mouth		Root					(L - 4)	(L)	(L - 5)	(L - 1)
	$d_{em,min}$	$d_{em,max}$		d_n	$D_{1,min}$	$D_{1,max}$	$D_{2,min}$				$D_{2,max}$	D_3	L_{min}	$L_{2,min}$
75	75,0	75,5	75	74,3	74,8	73,0	73,5	0,7	59	30	26	30	25	29
90	90,0	90,6	90	89,3	89,9	87,9	88,5	1,0	71	33	29	33	28	32
110	110,0	110,6	110	109,4	110,0	107,7	108,3	1,0	87	37	33	37	32	36
125	125,0	125,6	125	124,4	125,0	122,6	123,2	1,0	99	40	36	40	35	39

NOTE Maximum $L_2 = L$ mm and the minimum L_2 is calculated from $L - 4$ mm and the maximum $L_3 = L - 1$ mm and the minimum $L_3 = L - 5$ mm.

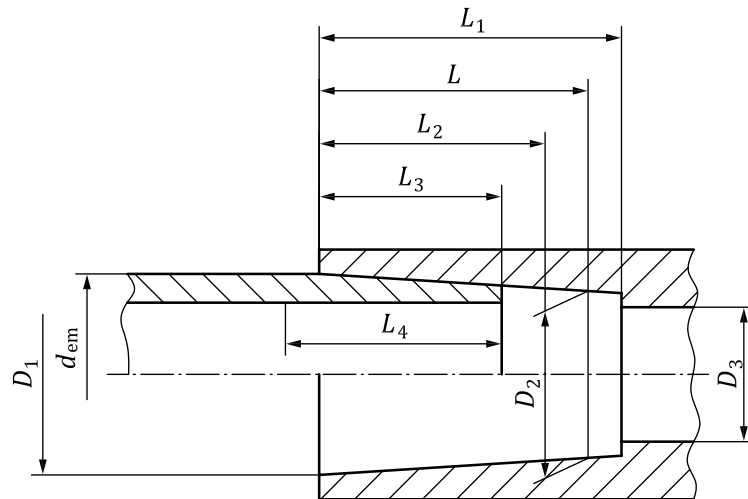
**Key**

- D_1 “mean inside mouth diameter” of the socket, i.e. the mean diameter of the circle at the intersection of the extension of the socket with the plane of the socket mouth
- D_2 “mean inside root diameter” of the socket, i.e. the mean diameter of the circle in a plane parallel to the plane of the mouth and separated from it by a distance of L which is the reference length of the socket
- D_3 “minimum bore”, i.e. the minimum diameter of the flow channel through the body of the fitting
- L “reference socket length”, i.e. the theoretical minimum socket length used for the purpose of calculation
- L_1 “actual length of the socket”, from mouth to shoulder, if any
- L_2 “heated length of the fitting”, i.e. the length of penetration of the heated tool into the socket
- L_3 “insertion depth”, i.e. the depth of the heated pipe end into the socket
- L_4 “heated length of pipe”, i.e. the depth of penetration of the pipe end into the heated tool
- d_{em} “mean outside diameter” of the pipe

Figure A.1 — Socket and pipe — symbols for dimensions

Annex B (informative)

Examples of typical terminal connection for electrofusion fittings

B.1 Figures B.1 and B.2 illustrate examples of terminal connections suitable for use with voltages less than or equal to 48 V (types A and B).

Dimensions in millimetres

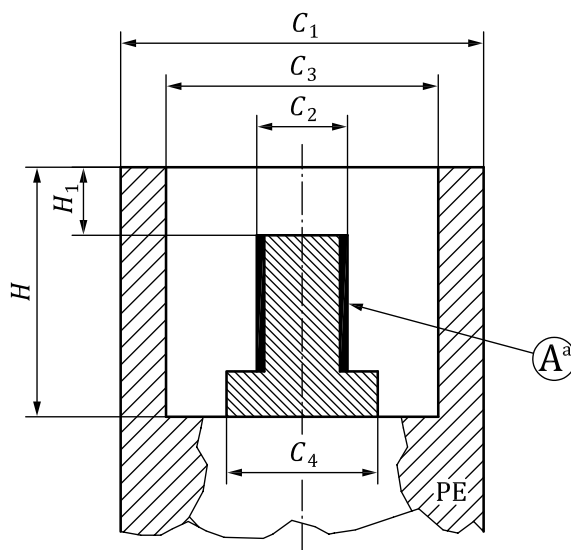

Key

A active part

C_1	outside diameter of the terminal shroud	$C_1 \geq 11,8$
C_2	diameter of the active part of the terminal	$C_2 = 4,00 \pm 0,1$
C_3	internal diameter of the terminal shroud	$C_3 = 9,5 \pm 1,0$
C_4	maximum overall diameter of the base of the active part	$C_4 \leq 6,0$
H	internal depth of the terminal	$H \geq 12,0$
H_1	distance between the upper part of the terminal shroud and the active part	$H_1 = 3,2 \pm 0,5$

^a The height of the active part, H_2 , is such that $7 \leq H_2 \leq H - H_1$.

Figure B.1 — Typical type A connection

Dimensions in millimetres

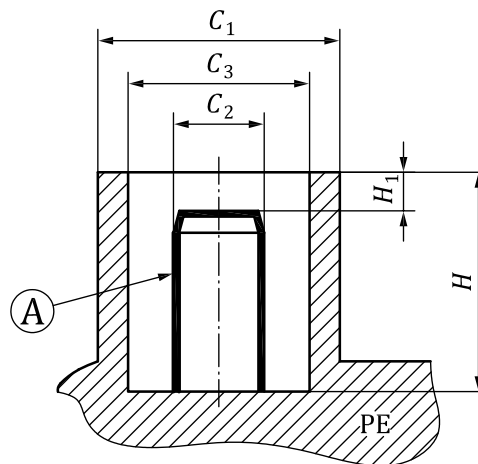
**Key**

A	active part	
C_1	outside diameter of the terminal shroud	$C_1 = 13,00 \pm 0,5$
C_2	diameter of the active part of the terminal	$C_2 = 4,70 \pm 0,1$
C_3	internal diameter of the terminal shroud	$C_3 = 10,0 -0,1/+0,5$
H	internal depth of the terminal shroud	$H \geq 15,5$
H_1	distance between the upper part of the terminal shroud and the active part	$H_1 = 4,5 \pm 0,5$

Figure B.2 — Typical type B connection

B.2 [Figure B.3](#) illustrates an example of a typical terminal connection suitable for use with voltages up to 250 V (type C).

Dimensions in millimetres

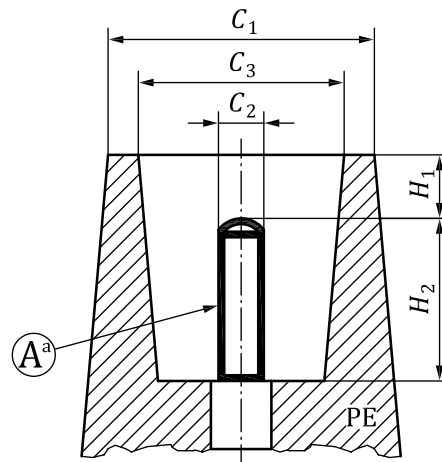

Key

- A active part
- C_1 outside diameter of the terminal shroud $C_1 \geq C_3 + 2,0$
- C_2 diameter of the active part of the terminal $C_2 \geq 2,0 \pm 0,1$
- C_3 internal diameter of the terminal shroud $C_3 \geq C_2 + 4,0$
- H_1 distance between the upper part of the terminal shroud and the active part H_1 : sufficient to ensure a degree of protection of IP 2 X as defined in IEC 60529[8]
- a The height of the active part, H_2 , is such that $7,0 \leq H_2$.

Figure B.3 — Typical type C connection

Annex C (normative)

Short-term pressure test method

C.1 Principle

A test piece, consisting of an electrofusion fitting assembled with one or more PE pipes having reduced free length sufficient to suppress pipe failure and create preferential failure in the fitting or in the connecting pipe-to-fitting joint, is placed in a controlled-temperature environment and subjected to an essentially continually increasing internal hydraulic pressure until failure occurs. The method is designed to establish the short-term failure pressure of the fitting/pipe assembly.

C.2 Apparatus

C.2.1 Constant-temperature water bath, in accordance with ISO 1167-1:2006, capable of being maintained at (20 ± 2) °C.

C.2.2 Pressure test equipment, in accordance with ISO 1167-1:2006, capable of applying a continuously increasing internal hydraulic pressure at a rate of (5 ± 1) bar/min²⁾ until the test piece fails.

C.2.3 Pressure gauge, having an accuracy of not less than 1 % of full-scale deflection and with a hand which indicates the maximum pressure reached.

A gauge shall be used that indicates the failure pressure at approximately mid-scale. The gauge should preferably be equipped with a surge protection device.

The gauge shall be located in a position within the pressure system such that it indicates the internal pressure of the test piece without being affected by pressure transients within the pressure supply lines, etc.

C.3 Test piece

The test piece shall be an assembly of one or more electrofusion fittings connected to PE pipes, with a minimum free pipe length between fittings of any type not exceeding d_n .

The pipes used shall be the thickest-walled pipe for which the fitting has been designed.

The test piece shall be closed with type A end caps in accordance with ISO 1167-1:2006.

C.4 Procedure

Attach the end caps to the test piece and fill it with water at ambient temperature.

Connect the test piece to the pressure source, ensuring that no air is trapped in the test assembly.

Immerse the test piece in the constant-temperature bath and condition it at (20 ± 2) °C for at least as long as the period defined in ISO 1167-1:2006 for the appropriate pipe wall thickness.

Increase the pressure uniformly at a rate of (5 ± 1) bar/min until failure of the test piece occurs.

2) 1 bar = 0,1 MPa = 10^5 Pa; 1 MPa = 1 N/mm².

Record the pressure at failure.

After testing, inspect the test piece and record the location and mode of failure.

C.5 Test report

The test report shall include the following information:

- a) a reference to this part of ISO 4437;
- b) all details necessary for complete identification of the pipes and socket fusion fittings used, including the manufacturer, type of material, and size of fitting and pipe;
- c) the details of the fusion-jointing procedure used to assemble the test piece;
- d) the pressure at failure;
- e) the time to failure;
- f) the failure location;
- g) the mode of failure, e.g. ductile in fitting, brittle along fusion interface;
- h) any factor that could have affected the results, such as any incidents or operating details not specified in [Annex C](#);
- i) the date of test.

Annex D (normative)

Tensile test for fitting/pipe assemblies

D.1 Principle

A test piece consisting of an electrofusion fitting and two connecting PE pipes is subjected to an increasing tensile load at a constant pulling rate until ductile pipe failure occurs. The test is conducted at a constant temperature and is intended to simulate the creation of longitudinal tensile loading along a pipeline as a consequence of external mechanical interference. Rupture of the fitting or the connecting fusion joints is not an acceptable failure mode.

D.2 Apparatus

This shall be in accordance with ISO 13951, with the additional requirement that the tensile-testing machine shall be capable of accommodating a test piece elongation of 25 % and of sustaining a constant test speed of $(5 \pm 1,25)$ mm/min.

D.3 Test piece

The test piece shall be in accordance with ISO 13951.

In cases where $d_n \geq 180$ mm and where the conduct of tensile tests on fitting/pipe assemblies is beyond the limits of the available test equipment, the testing of joint segments can be appropriate. Testing of segment test pieces shall not be undertaken, however, unless a correlation with testing of complete pipe/joint assemblies has been established.

NOTE When testing segmented test pieces, leak tightness is not checked.

D.4 Procedure

This shall be in accordance with ISO 13951, but without that International Standard's requirement for the load to be constant. The pulling rate shall be 5 mm/min \pm 25 %, sustained until a test piece elongation of 25 % is reached.

D.5 Test report

The test report shall include the following information:

- a) a reference to this part of ISO 4437;
- b) all details necessary for complete identification of the pipes and electrofusion fittings used, including the manufacturer, type of material, and size of fitting and pipe;
- c) the details of the fusion-jointing procedure used to assemble the test piece;
- d) the test temperature;
- e) the leak tightness and integrity of the fitting and fusion joint after 25 % elongation of the test piece;
- f) any factor that could have affected the results, such as an incident or operating detail not specified in [Annex D](#);

g) the date of test.

Annex E (informative)

Formulae for calculating the equivalent dimensions of non-metric electrofusion socket fitting series

E.1 For I-regulation, the minimum value of the penetration depth L_1 is given by

$L_1 = 20 \text{ mm}$	for $d_n < 50 \text{ mm}$;
$L_1 = 0,2 \times d_n + 10 \text{ mm}$	for $50 \text{ mm} < d_n < 250 \text{ mm}$;
$L_1 = 0,245 \times d_n + 12 \text{ mm}$	for $250 \text{ mm} \leq d_n < 500 \text{ mm}$;
$L_1 = 0,2 \times d_n + 35 \text{ mm}$	for $500 \text{ mm} \leq d_n \leq 630 \text{ mm}$.

E.2 For U-regulation, the minimum value of the penetration depth L_1 is given by

$L_1 = 25 \text{ mm}$	for $d_n < 50 \text{ mm}$;
$L_1 = 0,3 \times d_n + 12,5 \text{ mm}$	for $50 \text{ mm} \leq d_n < 110 \text{ mm}$;
$L_1 = 0,3 \times d_n + 20 \text{ mm}$	for $110 \text{ mm} \leq d_n \leq 630 \text{ mm}$.

E.3 The maximum value of the penetration depth L_1 is given by

$L_1 = 41 \text{ mm}$	for $d_n < 32 \text{ mm}$;
$L_1 = 0,6 \times d_n + 25 \text{ mm}$	for $32 \text{ mm} \leq d_n < 110 \text{ mm}$;
$L_1 = 0,335 \times d_n + 44,85 \text{ mm}$	for $110 \text{ mm} \leq d_n < 250 \text{ mm}$;
$L_1 = 0,333 \times d_n + 45,5 \text{ mm}$	for $250 \text{ mm} \leq d_n < 560 \text{ mm}$;
$L_1 = 0,286 \times d_n + 75 \text{ mm}$	for $560 \text{ mm} \leq d_n \leq 630 \text{ mm}$.

E.4 The minimum length of the fusion zone L_2 is given by

$L_2 = 10 \text{ mm}$	for $d_n < 50 \text{ mm}$;
$L_2 = 0,091 \times d_n + 5,1 \text{ mm}$	for $50 \text{ mm} \leq d_n < 250 \text{ mm}$;
$L_2 = 0,09 \times d_n + 10,2 \text{ mm}$	for $250 \text{ mm} \leq d_n < 400 \text{ mm}$;
$L_2 = 0,087 \times d_n + 12 \text{ mm}$	for $400 \text{ mm} \leq d_n \leq 630 \text{ mm}$.

E.5 The minimum unheated entrance length L_3 shall be 5 mm.

E.6 The minimum bore D_2 is given by Formula (E.1):

$$D_2 \geq d_n - 2 \times e_{\min} \tag{E.1}$$

where

e_{\min} is the minimum wall thickness specified for the corresponding pipe conforming to ISO 4437-2:2014.

E.7 All results shall be rounded to the nearest millimetre.

Bibliography

- [1] ISO/TS 10839, *Polyethylene pipes and fittings for the supply of gaseous fuels — Code of practice for design, handling and installation*
- [2] ISO 4427-3:2007, *Plastics piping systems — Polyethylene (PE) pipes and fittings for water supply — Part 3: Fittings*
- [3] EN 60335-1, *Household and similar electrical appliances — Safety — Part 1: General requirements (IEC 60335-1:2001, modified)*
- [4] HD 60364-1, *Low-voltage electrical installations — Part 1: Fundamental principles, assessment of general characteristics, definitions (IEC 60364-1:2005, modified)*
- [5] IEC 60449, *Voltage bands for electrical installations of buildings*
- [6] ISO 11922-1:1997, *Thermoplastics pipes for the conveyance of fluids — Dimensions and tolerances — Part 1: Metric series*
- [7] CEN/TS 1555-7, *Plastics piping systems for the supply of gaseous fuels — Polyethylene (PE) — Part 7: Guide for the assessment of conformity*
- [8] IEC 60529, *Degrees of protection provided by enclosures (IP Code)*

