**Plastics piping systems for non-pressure
underground drainage and sewerage —
Unplasticized poly(vinyl chloride)
(PVC-U)**

*Systèmes de canalisations en plastique pour les branchements et les
collecteurs d'assainissement enterrés sans pression — Poly(chlorure
de vinyle) non plastifié (PVC-U)*



Reference number
ISO 4435:2003(E)

© ISO 2003

PDF disclaimer

This PDF file may contain embedded typefaces. In accordance with Adobe's licensing policy, this file may be printed or viewed but shall not be edited unless the typefaces which are embedded are licensed to and installed on the computer performing the editing. In downloading this file, parties accept therein the responsibility of not infringing Adobe's licensing policy. The ISO Central Secretariat accepts no liability in this area.

Adobe is a trademark of Adobe Systems Incorporated.

Details of the software products used to create this PDF file can be found in the General Info relative to the file; the PDF-creation parameters were optimized for printing. Every care has been taken to ensure that the file is suitable for use by ISO member bodies. In the unlikely event that a problem relating to it is found, please inform the Central Secretariat at the address given below.

© ISO 2003

All rights reserved. Unless otherwise specified, no part of this publication may be reproduced or utilized in any form or by any means, electronic or mechanical, including photocopying and microfilm, without permission in writing from either ISO at the address below or ISO's member body in the country of the requester.

ISO copyright office
Case postale 56 • CH-1211 Geneva 20
Tel. + 41 22 749 01 11
Fax + 41 22 749 09 47
E-mail copyright@iso.org
Web www.iso.org

Published in Switzerland

Contents

Page

Foreword	iv
1 Scope	1
2 Normative references	1
3 Symbols and abbreviated terms	2
4 Material	3
5 General characteristics	5
6 Geometrical characteristics	5
7 Mechanical characteristics	16
8 Physical characteristics	18
9 Performance requirements	20
10 Sealing rings	20
11 Adhesives	20
12 Marking	20
Bibliography	22

Foreword

ISO (the International Organization for Standardization) is a worldwide federation of national standards bodies (ISO member bodies). The work of preparing International Standards is normally carried out through ISO technical committees. Each member body interested in a subject for which a technical committee has been established has the right to be represented on that committee. International organizations, governmental and non-governmental, in liaison with ISO, also take part in the work. ISO collaborates closely with the International Electrotechnical Commission (IEC) on all matters of electrotechnical standardization.

International Standards are drafted in accordance with the rules given in the ISO/IEC Directives, Part 2.

The main task of technical committees is to prepare International Standards. Draft International Standards adopted by the technical committees are circulated to the member bodies for voting. Publication as an International Standard requires approval by at least 75 % of the member bodies casting a vote.

Attention is drawn to the possibility that some of the elements of this document may be the subject of patent rights. ISO shall not be held responsible for identifying any or all such patent rights.

ISO 4435 was prepared by Technical Committee ISO/TC 138, *Plastics pipes, fittings and valves for the transport of fluids*, Subcommittee SC 1, *Plastics pipes and fittings for soil, waste and drainage (including land drainage)*.

This second edition cancels and replaces the first edition (ISO 4435:1991), which has been technically revised.

Plastics piping systems for non-pressure underground drainage and sewerage — Unplasticized poly(vinyl chloride) (PVC-U)

1 Scope

This International Standard specifies the requirements for unplasticized poly(vinyl chloride) (PVC-U) pipes, fittings and piping systems intended for use for non-pressure underground drainage and sewerage for the conveyance of soil and waste discharge of domestic and industrial origin, as well as surface water.

It covers buried pipework but does not apply to piping systems buried within the building structure.

In the case of industrial discharge, the chemical and temperature resistance have to be taken into account, but this will have to be done separately.

This International Standard is applicable to PVC-U pipes with or without an integral socket.

Fittings may be manufactured (i.e. produced on a large scale) by injection-moulding or be fabricated (i.e. produced on a small scale) from pipes and/or mouldings.

This International Standard also specifies the test parameters for the test methods referred to herein.

It does not cover requirements for the *K*-value of the raw material.

2 Normative references

The following referenced documents are indispensable for the application of this document. For dated references, only the edition cited applies. For undated references, the latest edition of the referenced document (including any amendments) applies.

ISO 265-1, *Pipes and fittings of plastics materials — Fittings for domestic and industrial waste pipes — Basic dimensions: Metric series — Part 1: Unplasticized poly(vinyl chloride) (PVC-U)*

ISO 3126:—¹⁾, *Plastics piping systems — Plastics piping components — Measurement and determination of dimensions*

ISO 4633, *Rubber seals — Joint rings for water supply, drainage and sewerage pipelines — Specification for materials*

EN 580, *Plastics piping systems — Unplasticized poly(vinyl chloride) (PVC-U) pipes — Test method for the resistance to dichloromethane at a specified temperature (DCMT)*

EN 727, *Plastics piping and ducting systems — Thermoplastics pipes and fittings — Determination of Vicat softening temperature (VST)*

1) To be published. (Revision of ISO 3126:1974)

EN 743:1994, *Plastics piping and ducting systems — Thermoplastics pipes — Determination of the longitudinal reversion*

EN 744, *Plastics piping and ducting systems — Thermoplastics pipes — Test method for resistance to external blows by the round-the-clock method*

EN 763:1994, *Plastics piping and ducting systems — Injection-moulded thermoplastics fittings — Test method for visually assessing effects of heating*

EN 921, *Plastics piping systems — Thermoplastics pipes — Determination of resistance to internal pressure at constant temperature*

EN 1053, *Plastics piping systems — Thermoplastics piping systems for non-pressure applications — Test method for watertightness*

EN 1277, *Plastics piping systems — Thermoplastics piping systems for buried non-pressure applications — Test methods for leaktightness of elastomeric sealing ring type joints*

EN 1411, *Plastics piping and ducting systems — Thermoplastics pipes — Determination of resistance to external blows by the staircase method*

EN 1905, *Plastics piping systems — Unplasticized poly(vinyl chloride) (PVC-U) pipes, fittings and material — Method for assessment of the PVC content based on total chlorine content*

EN 12061, *Plastics piping systems — Thermoplastics fittings — Test method for impact resistance*

EN 12256, *Plastics piping systems — Thermoplastics fittings — Test method for mechanical strength or flexibility of fabricated fittings*

3 Symbols and abbreviated terms

3.1 Symbols

The following symbols are used in this International Standard. Their meanings are illustrated in the respective figures.

A	length of engagement
a	circumferential side cover of a saddle branch
B	length of lead-in
C	depth of sealing zone
d_{em}	mean outside diameter
d_n	nominal outside diameter
d_{sm}	mean inside diameter of a socket
DN	nominal size
DN/OD	nominal size, outside diameter related
d_3	internal diameter of groove
e	wall thickness

e_m	mean wall thickness
e_2	wall thickness of a socket
e_3	wall thickness in the groove area
f	groove width
H	length of chamfer
L	axial cover of a saddle branch
L_1	length of spigot
L_2	length of a solvent cement socket
l	effective length of a pipe
M	length of spigot of a plug
R	radius of a swept fitting
z	laying length (z -length)
α	angle of a fitting

3.2 Abbreviated terms

PVC-U	unplasticized poly(vinyl chloride)
SDR	standard dimension ratio
SN	nominal stiffness
TIR	true impact rate

4 Material

4.1 Raw material

The raw material shall be PVC-U to which have been added those additives that are needed to facilitate the manufacture of components conforming to the requirements of this International Standard.

It is recommended that the requirements given in EN 1401-1 be followed for the use of non-virgin material.

NOTE Definitions relating to materials are given in EN 1401-1.

The PVC content shall be at least 80 % by mass for pipes and 85 % by mass for injection-moulded fittings when calculated on the basis of a known formulation or (in cases of dispute or when the formulation is not known) determined in accordance with EN 1905.

4.2 Pipe material

When tested in accordance with the method specified in Table 1, using the parameters indicated, the pipe material shall conform to the requirement given in Table 1.

The pipe material shall be tested in the form of a pipe.

Table 1 — Pipe material

Characteristic	Requirement	Test parameters		Test method
Resistance to internal pressure	No failure during test period	End caps	Type A or B ^a	EN 921
		Test temperature	60 °C	
		Orientation	Not specified	
		Number of test pieces	3	
		Circumferential (hoop) stress	10,0 MPa	
		Conditioning period	1 h	
		Type of test	Water-in-water	
		Test period	1 000 h	
^a In cases of dispute, the manufacturer shall declare the type of end cap to be used.				

4.3 Fitting material

When tested in accordance with the method specified in Table 2, using the parameters indicated, the fitting material shall conform to the requirement given in Table 2.

The fitting material shall be tested, without further modification, in the form of an extruded or injection-moulded pipe.

When fittings or parts of fittings are fabricated (i.e. produced on a small scale), they shall be made from pipes conforming to this International Standard, except for the requirements for the wall thickness, and/or from mouldings made from PVC-U which conforms to the material, mechanical and physical characteristics required by this International Standard.

Table 2 — Fitting material

Characteristic	Requirement	Test parameters		Test method
Resistance to internal pressure	No failure during test period	End caps	Type A or B ^a	EN 921
		Dimensions	$50 \text{ mm} \leq d_n \leq 110 \text{ mm}$ $3 \text{ mm} \leq e \leq 5 \text{ mm}$	
		Free length of injection-moulded pipe	$\geq 140 \text{ mm}$	
		Test temperature	60 °C	
		Orientation	Not specified	
		Number of test pieces	3	
		Circumferential (hoop) stress	6,3 MPa	
		Conditioning period	1 h	
		Type of test	Water-in-water	
		Test period	1 000 h	
^a In cases of dispute, the manufacturer shall declare the type of end cap to be used.				

4.4 Sealing ring retaining means

Sealing rings may be retained using components made from polymers other than PVC-U.

5 General characteristics

5.1 Appearance

When viewed without magnification, pipes and fittings shall meet the following requirements:

- the internal and external surfaces shall be smooth, clean and free from grooving, blistering, impurities, pores and any other surface irregularity likely to prevent conformity with this International Standard;
- each end shall be cleanly cut, if applicable, and shall be square to its axis.

5.2 Colour

Pipes and fittings shall be coloured through the whole wall.

NOTE The colour should preferably be orange-brown (approximately RAL 8023)²⁾ or dusty grey (approximately RAL 7037)²⁾. Other colours may be used, however.

6 Geometrical characteristics

6.1 General

All dimensions shall be measured in accordance with ISO 3126:—.

The figures given in this International Standard are schematic sketches only, to indicate the relevant dimensions. They do not necessarily represent manufactured components. The dimensions given shall be conformed to however.

2) As specified in RAL 840-HR, obtainable from Beuth Verlag GmbH, 1000 Berlin 30.

6.2 Dimension of pipes

6.2.1 Outside diameter

The mean outside diameter d_{em} shall be as specified in Table 3.

Table 3 — Mean outside diameters

Dimensions in millimetres

Nominal size ^a DN/OD	Nominal outside diameter d_n	Mean outside diameter d_{em}	
		min.	max.
110	110	110,0	110,3
125	125	125,0	125,3
160	160	160,0	160,4
200	200	200,0	200,5
250	250	250,0	250,5
315	315	315,0	315,6
(355)	355	355,0	355,7
400	400	400,0	400,7
(450)	450	450,0	450,8
500	500	500,0	500,9
630	630	630,0	631,1
(710)	710	710,0	711,2
800	800	800,0	801,3
(900)	900	900,0	901,5
1 000	1 000	1 000,0	1 001,6

^a Non-preferred sizes are indicated in parentheses.

6.2.2 Out-of-roundness

The out-of-roundness, measured directly after production, shall be less than or equal to $0,024d_n$.

6.2.3 Effective lengths of pipes

The effective length l of a pipe shall be not less than that specified by the manufacturer when measured as shown in Figure 1.

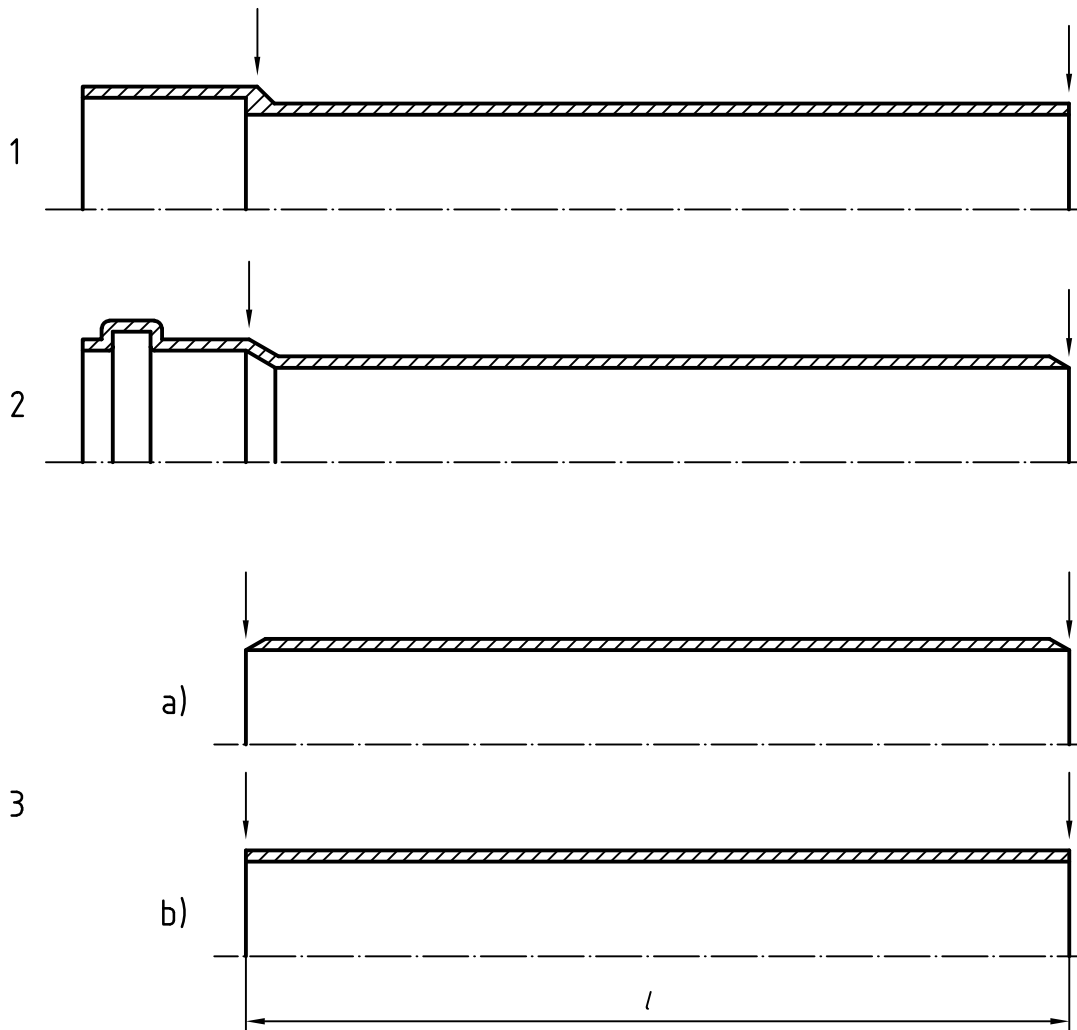
**Key**

- 1 single-socket pipe
- 2 ring-seal pipe
- 3 plain-ended pipe
 - a) with chamfer
 - b) without chamfer

Figure 1 — Effective lengths of pipes**6.2.4 Chamfering**

If a chamfer is applied, the angle of chamfering shall be between 15° and 45° to the axis of the pipe (see Figure 2 and Table 5 or Figure 7 and Table 8, as applicable).

The wall thickness remaining at the end of the pipe shall be at least one-third of e_{\min} .

6.2.5 Wall thickness

The wall thickness e shall be as specified in Table 4, although a localized maximum wall thickness at any point of $1,2e_{\min}$ is permitted provided that the mean wall thickness e_m is less than or equal to the specified $e_{m,\max}$.

Table 4 — Wall thicknesses

Dimensions in millimetres

Nominal size ^a DN/OD	Nominal outside diameter d_n	SN 2		SN 4		SN 8	
		SDR 51		SDR 41		SDR 34	
		e min.	e_m max.	e min.	e_m max.	e min.	e_m max.
110	110	—	—	3,2	3,8	3,2	3,8
125	125	—	—	3,2	3,8	3,7	4,3
160	160	3,2	3,8	4,0	4,6	4,7	5,4
200	200	3,9	4,5	4,9	5,6	5,9	6,7
250	250	4,9	5,6	6,2	7,1	7,3	8,3
315	315	6,2	7,1	7,7	8,7	9,2	10,4
(355)	355	7,0	7,9	8,7	9,8	10,4	11,7
400	400	7,9	8,9	9,8	11,0	11,7	13,1
(450)	450	8,8	9,9	11,0	12,3	13,2	14,8
500	500	9,8	11,0	12,3	13,8	14,6	16,3
630	630	12,3	13,8	15,4	17,2	18,4	20,5
(710)	710	13,9	15,5	17,4	19,4	—	—
800	800	15,7	17,5	19,6	21,8	—	—
(900)	900	17,6	19,6	22,0	24,4	—	—
1 000	1 000	19,6	21,8	24,5	27,2	—	—

^a Non-preferred sizes are indicated in parentheses.

6.3 Dimensions of fittings

6.3.1 Outside diameter

The mean outside diameter d_{em} of the spigot shall be as specified in Table 3.

The out-of-roundness shall conform to the requirement given in 6.2.2.

6.3.2 Laying length

The laying length z shall be stated by the manufacturer.

NOTE The laying lengths (z -lengths, see Figure 7 to Figure 18) of fittings are intended to assist in the design of moulds and are not intended to be used for quality control purposes.

ISO 265-1 may be used as a guide.

6.3.3 Wall thickness

6.3.3.1 The minimum wall thickness e_{\min} of the body or the spigot of a fitting shall be as specified in Table 4, except that a reduction of 5 % resulting from core shifting is permitted. In such cases, the average of two opposite wall thicknesses shall be equal to or exceed the values given in Table 4.

6.3.3.2 Where a fitting or adaptor is used to provide a transition between two nominal sizes, the wall thickness of each connecting part shall conform to the requirements for the applicable nominal size. In such cases, the wall thickness of the fitting body may change gradually from the one wall thickness to the other.

6.3.3.3 The wall thickness of the cover of a saddle branch (see Figure 17) shall be equal to or greater than e_{\min} for the applicable size and series (see Table 4) of the inlet branch.

6.3.3.4 The wall thicknesses of fabricated fittings, except for those of the spigot and socket, may be changed locally by the fabrication process, providing that the minimum wall thickness of the body conforms to the value of $e_{3,\min}$ given in Table 6 for the SDR class concerned.

6.4 Dimensions of sockets and spigots

6.4.1 Elastomeric ring seal sockets and spigots

6.4.1.1 Diameter and length

The diameter and length of elastomeric ring seal sockets and spigots shall be as specified in Table 5 (see Figure 2, 3 or 4, as applicable).

Where sealing rings are firmly retained, the minimum value of A and the maximum value of C shall be measured to the effective sealing point (see Figure 4), as specified by the manufacturer, to ensure a full sealing action.

Designs of elastomeric ring seal socket and spigot other than those shown may be used, provided that the joints conform to the requirements given in Table 5.

Table 5 — Diameters and lengths of elastomeric ring seal sockets and spigots

Dimensions in millimetres

Nominal size ^a DN/OD	Nominal outside diameter d_n	Socket			Spigot	
		d_{sm} min.	A min.	C max.	L_1 min.	H^b
110	110	110,4	32	26	60	6
125	125	125,4	35	26	67	6
160	160	160,5	42	32	81	7
200	200	200,6	50	40	99	9
250	250	250,8	55	70	125	9
315	315	316,0	62	70	132	12
(355)	355	356,1	66	70	136	13
400	400	401,2	70	80	150	15
(450)	450	451,4	75	80	155	17
500	500	501,5	80	80 ^c	160	18
630	630	631,9	93	95 ^c	188	23
(710)	710	712,1	101	109 ^c	210	28
800	800	802,4	110	110 ^c	220	32
(900)	900	902,7	120	125 ^c	245	36
1 000	1 000	1 003,0	130	140 ^c	270	41

^a Non-preferred sizes are indicated in parentheses.

^b Approximate values when a 15° chamfer is applied.

^c Higher values of C are allowed, provided the manufacturer states in his documentation the actual value of $L_{1,min}$ required by the equation $L_{1,min} = A_{min} + C$.

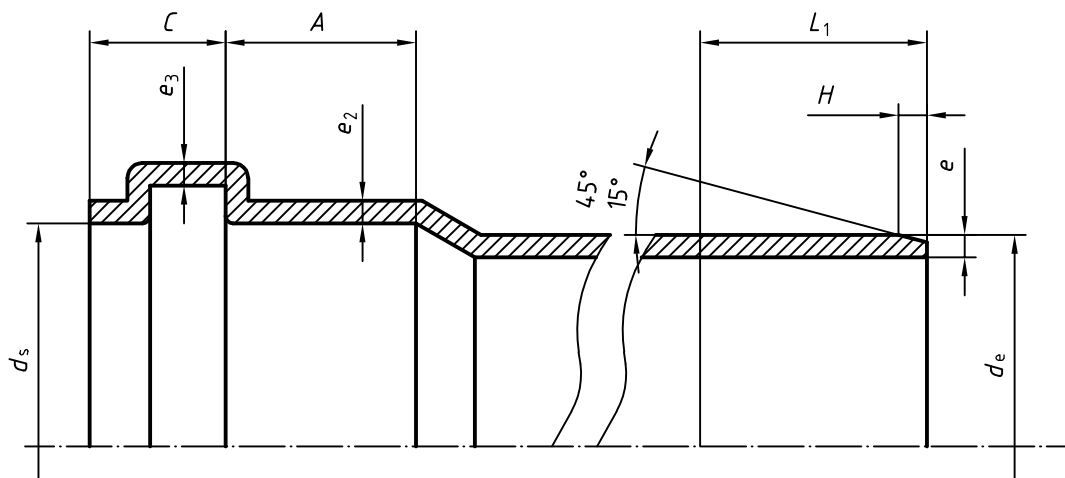

Figure 2 — Basic dimensions of sockets and spigots for elastomeric ring seal joints

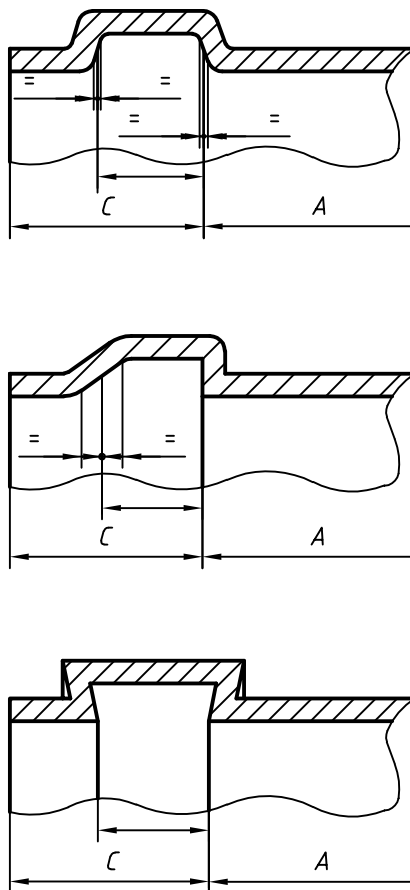

Figure 3 — Typical groove designs for elastomeric ring seal sockets

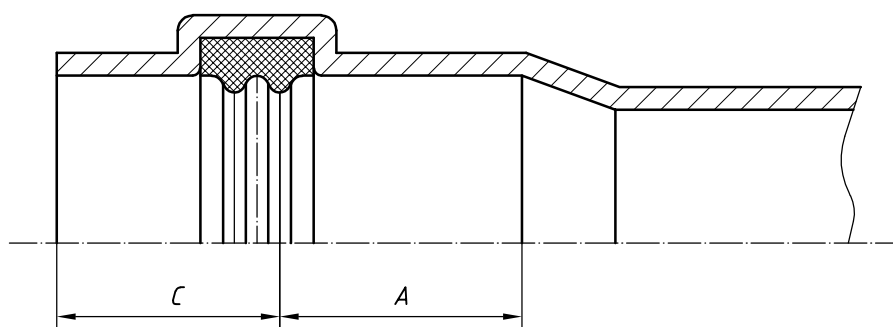

Figure 4 — Example of measurement of effective sealing point

6.4.1.2 Wall thickness of sockets

The wall thickness of sockets, e_2 and e_3 (see Figure 2), except at the socket mouth, shall be as specified in Table 6.

A reduction in e_2 and e_3 of 5 % resulting from core shifting is permitted. In such cases, the average of two opposite wall thicknesses shall be equal to or exceed the values given in Table 6.

Table 6 — Wall thicknesses of sockets

Dimensions in millimetres

Nominal size ^a DN/OD	Nominal outside diameter d_n	SN 2 SDR 51		SN 4 SDR 41		SN 8 SDR 34	
		e_2 min.	e_3 min.	e_2 min.	e_3 min.	e_2 min.	e_3 min.
110	110	—	—	2,9	2,4	2,9	2,4
125	125	—	—	2,9	2,4	3,4	2,8
160	160	2,9	2,4	3,6	3,0	4,3	3,6
200	200	3,6	3,0	4,4	3,7	5,4	4,5
250	250	4,5	3,7	5,5	4,7	6,6	5,5
315	315	5,6	4,7	6,9	5,8	8,3	6,9
(355)	(355)	6,3	5,3	7,8	6,6	9,4	7,8
400	400	7,1	6,0	8,8	7,4	10,6	8,8
(450)	(450)	8,0	6,6	9,9	8,3	11,9	9,9
500	500	8,9	7,4	11,1	9,3	13,2	11,0
630	630	11,1	9,3	13,9	11,6	16,6	13,8
(710)	(710)	12,6	10,5	15,7	13,1	—	—
800	800	14,1	11,8	17,7	14,7	—	—
(900)	(900)	16,0	13,2	19,8	16,5	—	—
1 000	1 000	17,8	14,7	22,0	18,4	—	—

^a Non-preferred sizes are indicated in parentheses.

Where a sealing ring is located by means of a retaining cap or ring (see Figure 5), the wall thickness in this area shall be calculated by addition of the wall thickness of the socket and the wall thickness of the retaining cap or ring at the corresponding places in the same cross-sectional plane.

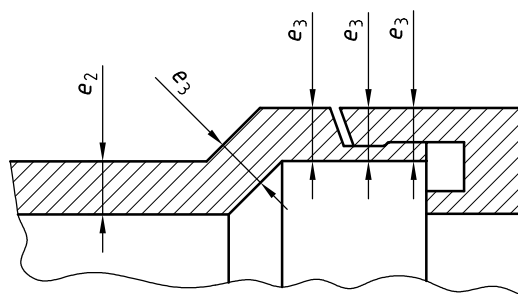

Figure 5 — Example of calculation of wall thickness of socket with retaining cap

6.4.2 Solvent cement sockets and spigots

6.4.2.1 Diameter and length

The diameter and length of solvent cement sockets and spigots (see Figure 6) shall be as specified in Table 7.

The manufacturer shall declare whether the socket is of a tapered or parallel-sided design. If it is parallel-sided or nearly so, the mean inside diameter of the socket d_{sm} shall apply over the entire length of the socket. If the socket is tapered, then the limits for d_{sm} shall apply at the mid-point of the socket and the maximum taper angle shall be 20' relative to the axis of the socket.

Table 7 — Diameters and lengths of solvent cement sockets and spigots

Dimensions in millimetres

Nominal size DN/OD	Nominal outside diameter d_n	Socket ^a			Spigot	
		d_{sm} min.	d_{sm} max.	L_2 min.	L_1 min.	H^b
110	110	110,2	110,6	48	54	6
125	125	125,2	125,7	51	61	6
160	160	160,3	160,8	58	74	7
200	200	200,4	200,9	66	90	9

^a The length of the socket shall be measured to the root of the socket.
^b Approximate values when a 15° chamfer is applied.

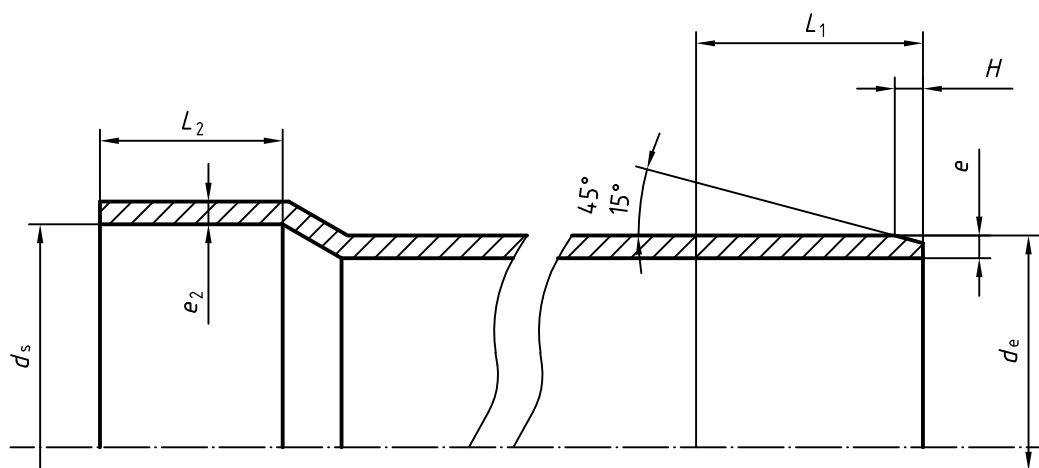

Figure 6 — Basic dimensions of sockets and spigots for solvent cement joints

6.4.2.2 Wall thickness of sockets

The wall thickness of sockets, e_2 (see Figure 6), shall be as specified in Table 6.

6.5 Types of fitting

This International Standard is applicable to the following generic types of fitting. Other designs of fitting are permitted.

ISO 4435:2003(E)

a) Bends (see Figure 7, 8, 9 or 10)

- unswept or swept (see ISO 265-1);
- spigot/socket and socket/socket.

The nominal angle, α , may be selected from the following: 15°, 30°, 45°, 67°30' and 87°30' to 90°.

b) Couplers and slip couplers (see Figure 11).

c) Reducers (see Figure 12).

d) Branches and reducing branches (see Figure 13, 14, 15 or 16)

- unswept or swept (see ISO 265-1);
- spigot/socket and socket/socket.

The nominal angle, α , may be selected from the following: 45°, 67°30' and 87°30' to 90°.

e) Saddle branches (see Figure 17).

f) Plugs (see Figure 18).

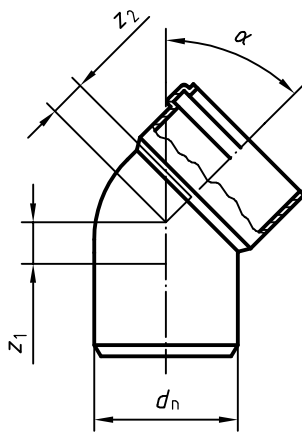

Figure 7 — Bend with single socket (unswept)

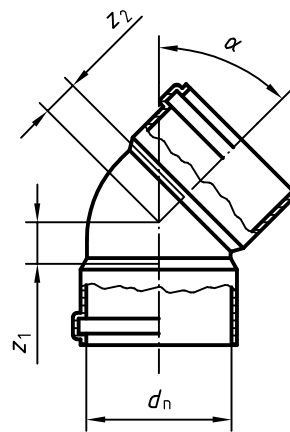

Figure 8 — Bend with only sockets (unswept)

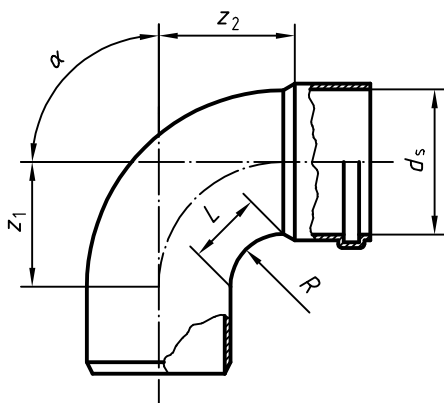

Figure 9 — Bend with single socket (swept)

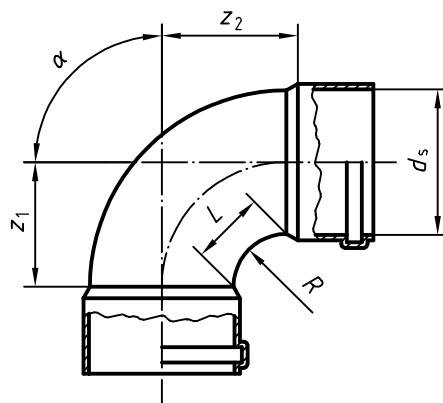

Figure 10 — Bend with only sockets (swept)

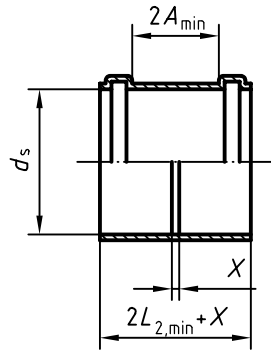

Figure 11 — Coupler

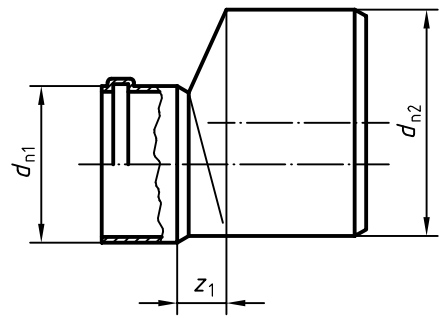

Figure 12 — Reducer

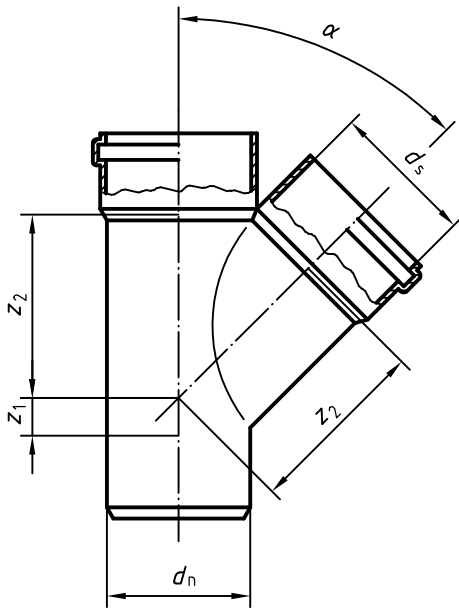

Figure 13 — Branch with single socket (unswept)

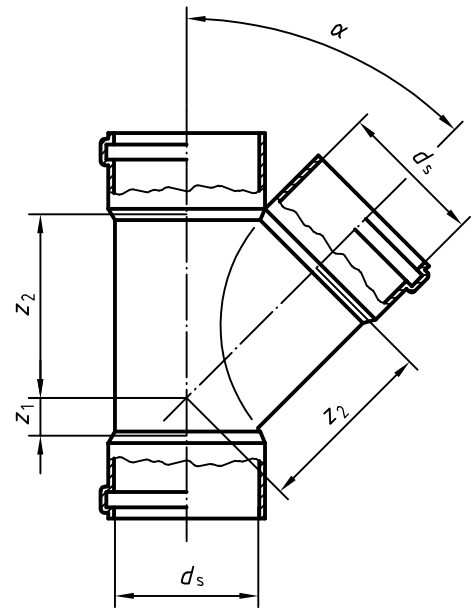

Figure 14 — Branch with only sockets (unswept)

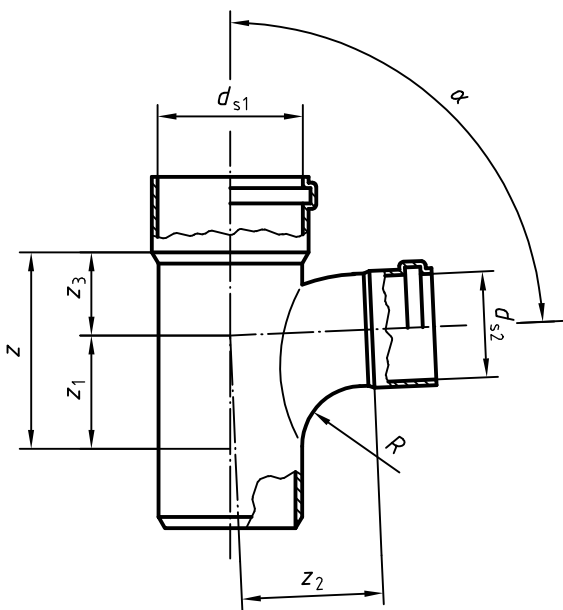

Figure 15 — Reducing branch with single socket (swept)

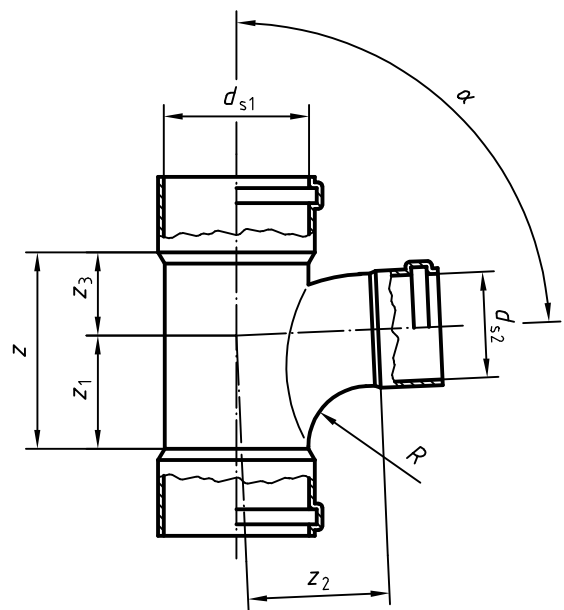

Figure 16 — Reducing branch with only sockets (swept)

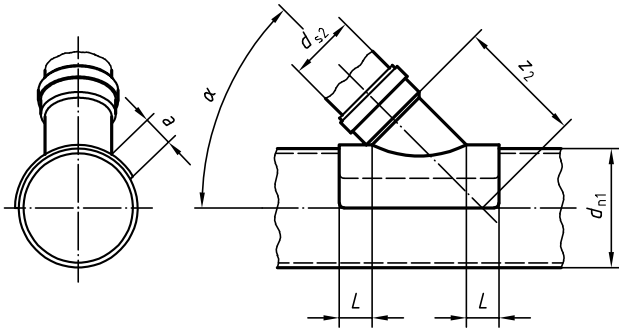

Figure 17 — Saddle branch

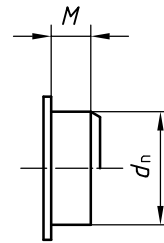

Figure 18 — Plug

7 Mechanical characteristics

7.1 Mechanical characteristics of pipes

7.1.1 Impact resistance (round-the-clock method)

When determined in accordance with the method specified in Table 8, using the parameters indicated, the impact resistance of pipes shall conform to the requirements given in Table 8.

Table 8 — General mechanical characteristics of pipes

Characteristic	Requirement	Test parameters		Test method
Impact resistance ^a (round-the-clock method)	TIR ≤ 10 %	Conditioning and test temperature	0 °C	EN 744
		Conditioning medium	Water or air	
		Type of striker	d90	
		Mass of striker for:		
		$d_n = 110 \text{ mm}$	1,0 kg	
		$d_n = 125 \text{ mm}$	1,25 kg	
		$d_n = 160 \text{ mm}$	1,6 kg	
		$d_n = 200 \text{ mm}$	2,0 kg	
		$d_n = 250 \text{ mm}$	2,5 kg	
		$d_n \geq 315 \text{ mm}$	3,2 kg	
		Fall height of striker for:		
		$d_n = 110 \text{ mm}$	1 600 mm	
		$d_n \geq 125 \text{ mm}$	2 000 mm	
^a If the manufacturer chooses to use indirect testing, the preferred temperature is (23 ± 2) °C.				

7.1.2 Additional characteristics

Pipes intended to be used in areas where installation is usually carried out at temperatures below -10 °C shall additionally conform to the requirements of an impact test (staircase method), as specified in Table 9.

Table 9 — Additional mechanical characteristics of pipes

Characteristic	Requirements	Test parameters		Test method
Impact resistance (staircase method)	$H_{50} \geq 1\text{ m}$ Max. 1 break below 0,5 m	Conditioning and test temperature	0 °C	EN 1411
		Type of striker	d90	
		Mass of striker for:		
		$d_n = 110\text{ mm}$	4,0 kg	
		$d_n = 125\text{ mm}$	5,0 kg	
		$d_n = 140\text{ mm}$	6,3 kg	
		$d_n = 160\text{ mm}$	8,0 kg	
		$d_n = 180\text{ mm}$	8,0 kg	
		$d_n = 200\text{ mm}$	10,0 kg	
		$d_n \geq 250\text{ mm}$	12,5 kg	

7.2 Mechanical characteristics of fittings

When determined in accordance with the methods specified in Table 10, using the parameters indicated, the general mechanical characteristics of fittings shall conform to the requirements given in Table 10.

Table 10 — Mechanical characteristics of fittings

Characteristic	Requirement	Test parameters		Test method
Mechanical strength or flexibility ^a	No sign of splitting, cracking, separation or leakage	Test period	15 min	EN 12256
		Minimum moment for: DN \leq 250	$0,15(\text{DN})^3 \times 10^{-6}\text{ kN}\cdot\text{m}$	
		DN $>$ 250	$0,01(\text{DN})\text{ kN}\cdot\text{m}$	
	or	Minimum displacement	170 mm	
Impact strength (drop test)	No damage	Conditioning and test temperature	0 °C	EN 12061
		Fall height for:		
		$d_n = 110\text{ mm}$	1 000 mm	
		$d_n = 125\text{ mm}$	1 000 mm	
		$d_n = 160\text{ mm}$	500 mm	
		$d_n = 200\text{ mm}$	500 mm	
		Point of impact	Mouth of socket	

^a Only for fabricated fittings made from more than one piece. A sealing ring retaining component is not considered as a separate piece.

8 Physical characteristics

8.1 Physical characteristics of pipes

When determined in accordance with the methods specified in Table 11, using the parameters indicated, the physical characteristics of pipes shall conform to the requirements given in Table 11.

Table 11 — Physical characteristics of pipes

Characteristic	Requirements	Test parameters		Test method
Vicat softening temperature (VST)	≥ 79 °C	As specified in EN 727		EN 727
Longitudinal reversion ^a	≤ 5 % The pipe shall exhibit no bubbles or cracks	Test temperature	150 °C	EN 743:1994 Method A: liquid
		Immersion time for:		
		$e \leq 8$ mm	15 min	
$e > 8$ mm	30 min	or		
		Test temperature	150 °C	EN 743:1994 Method B: air
		Immersion time for:		
$e \leq 4$ mm	30 min			
$4 \text{ mm} < e \leq 16 \text{ mm}$	60 min			
		$e > 16$ mm	120 min	
Resistance to dichloromethane at a specified temperature	No attack at any part of surface of test piece	Test temperature	15 °C	EN 580
		Immersion time	30 min	
^a In cases of dispute, the manufacturer shall declare which of the two test methods is to be used.				

8.2 Physical characteristics of fittings

When determined in accordance with the methods specified in Table 12 or Table 13, using the parameters indicated, the physical characteristics of fittings shall conform to the requirements given in Table 12 or Table 13, as applicable.

Table 12 — Physical characteristics of fittings

Characteristic	Requirements	Test parameters		Test method
Vicat softening temperature(VST)	≥ 77 °C	As specified in EN 727		EN 727
Effects of heating	See footnotes ^a and ^b	Test temperature	150 °C	EN 763:1994 Method A: air oven
		Heating time for:		
		$e \leq 10$ mm	30 min	
		$e > 10$ mm	60 min	
^a 1) Within a radius of 15 times the wall thickness around the injection point(s), the depth of any cracks, delamination or blisters shall not exceed 50 % of the wall thickness at the point being assessed. 2) Within a distance of 10 times the wall thickness from the diaphragm zone, the depth of any cracks, delamination or blisters shall not exceed 50 % of the wall thickness at the point being assessed. 3) Within a distance of 10 times the wall thickness from the ring gate, the length of any cracks shall not exceed 50 % of the wall thickness at the point being assessed. 4) The weld line shall not have opened by more than 50 % of the wall thickness at the line. 5) At all other parts of the surface, the depth of any cracks or delamination shall not exceed 30 % of the wall thickness at the point being assessed. Blisters shall not exceed a length 10 times the wall thickness.				
^b After cutting through the fitting, the cut surfaces, when viewed without magnification, shall show no foreign particles.				

Table 13 — Additional physical characteristics of fabricated fittings

Characteristic	Requirement	Test parameters		Test method
Watertightness ^a	No leakage	Water pressure	0,5 bar ^b	EN 1053
		Duration	1 min	
^a Only for fabricated fittings made from more than one piece. A sealing ring retaining component is not considered as a separate piece.				
^b 1 bar = 10^5 N/m ² = 0,1 MPa.				

9 Performance requirements

When determined in accordance with the methods specified in Table 14, using the parameters indicated, the fitness-for-purpose characteristics of the joints and the system shall conform to the requirements given in Table 14.

Table 14 — Performance requirements

Characteristic	Requirements	Test parameters		Test method
Tightness of elastomeric sealing ring joints		Test temperature	(23 ± 5) °C	EN 1277:1996 Method 4 Set of conditions B
		Spigot deflection	≥ 10 %	
		Socket deflection	≥ 5 %	
		Difference	≥ 5 %	
	No leakage	Water pressure	0,05 bar	
	No leakage	Water pressure	0,5 bar	
	≤ -0,27 bar	Air pressure	-0,3 bar	
		Test temperature	(23 ± 5) °C	EN 1277:1996 Method 4 Set of conditions C
		Angular deflection for:		
		$d_n \leq 315 \text{ mm}$	2°	
		$315 \text{ mm} \leq d_n \leq 630 \text{ mm}$	1,5°	
		$d_n > 630 \text{ mm}$	1°	
	No leakage	Water pressure	0,05 bar	
	No leakage	Water pressure	0,5 bar	
≤ -0,27 bar	Air pressure	-0,3 bar		

10 Sealing rings

Sealing rings shall not have any detrimental effect on the properties of the pipe or fitting and shall not cause the test assembly to fail to conform to the requirements of Table 14.

For further requirements for rubber sealing rings for drainage purposes, see ISO 4633.

11 Adhesives

The adhesive used shall be solvent cement as specified by the manufacturer of the pipes or fittings.

The adhesive shall have no detrimental effects on the properties of the pipe or fitting and shall not cause the test assembly to fail to conform to the requirements of Table 14.

12 Marking

12.1 General

12.1.1 Marking elements shall be labelled or printed or formed directly on the pipe or fitting and/or labelled or printed on the packaging.

12.1.2 Marking on a pipe or fitting shall not initiate cracks or other types of defect likely to prevent conformity to the requirements of this International Standard.

12.2 Minimum required marking of pipes

The minimum marking required for pipes is specified in Table 15.

Pipes shall be marked at intervals of, at the maximum, 2 m, at least once per pipe.

Table 15 — Minimum required marking of pipes

Item	Marking or symbol
Number of standard ^a	e.g. ISO 4435
Manufacturer's name and/or trademark	XXX
Nominal size	e.g. DN 200
Minimum wall thickness or SDR	e.g. 4,9 or SDR 41
Nominal ring stiffness	e.g. SN 4
Material	PVC or PVC-U
Manufacturer's information	b
Cold-climate performance ^c	❄ (ice crystal)
<p>^a The number of this International Standard or of a conforming national standard.</p> <p>^b To ensure traceability, the following details shall be given:</p> <ul style="list-style-type: none"> — the production period (year and month), in figures or in code; — a name or code for the production site if the manufacturer is producing at different sites. <p>^c This marking is only applicable to pipes which have been proved, by testing, to conform to 7.1.2.</p>	

12.3 Minimum required marking of fittings

The minimum marking required for fittings is specified in Table 16.

Table 16 — Minimum required marking of fittings

Item	Marking or symbol
Number of standard ^a	e.g. ISO 4435
Manufacturer's name and/or trademark	XXX
Nominal size	e.g. DN 200
Nominal angle	e.g. 45°
Minimum wall thickness or SDR	e.g. 4,9 or SDR 41
Material	PVC or PVC-U
Manufacturer's information	b
<p>^a The number of this International Standard or of a conforming national standard.</p> <p>^b To ensure traceability, the following details shall be given:</p> <ul style="list-style-type: none"> — the production period (year and month), in figures or in code; — a name or code for the production site if the manufacturer is producing at different sites. 	

Bibliography

- [1] EN 1401-1, *Plastics piping systems for non-pressure underground drainage and sewerage — Unplasticized poly(vinyl chloride) (PVC-U) — Part 1: Specifications for pipes, fittings and the system*

ICS 83.140.30; 93.030

Price based on 22 pages

<https://www.iso.org/standard/4435.html>