

INTERNATIONAL
STANDARD

ISO
4412-3

First edition
1991-08-15

**Hydraulic fluid power — Test code for
determination of airborne noise levels —**

Part 3:

**Pumps — Method using a parallelepiped
microphone array**

*Transmissions hydrauliques — Code d'essai pour la détermination du
niveau de bruit aérien —*

*Partie 3: Pompes — Méthode employant un étalage des microphones en
parallélépipède*



Reference number
ISO 4412-3:1991(E)

ISO 4412-3:1991(E)

Contents

	Page
1 Scope	1
2 Normative references	1
3 Definitions	1
4 Measurement uncertainty	2
5 Test environment	2
6 Instrumentation	2
7 Installation conditions	3
8 Operating conditions	3
9 Location and number of sound measurement points	3
10 Test procedure	4
11 Calculation of surface sound pressure levels and sound power levels	5
12 Information to be recorded	5
13 Test report	6
14 Identification statement (Reference to this part of ISO 4412)	7
 Annexes	
A Errors and classes of measurement	8
B Bibliography	9

© ISO 1991

All rights reserved. No part of this publication may be reproduced or utilized in any form or by any means, electronic or mechanical, including photocopying and microfilm, without permission in writing from the publisher.

International Organization for Standardization
Case Postale 56 • CH-1211 Genève 20 • Switzerland

Printed in Switzerland

Foreword

ISO (the International Organization for Standardization) is a worldwide federation of national standards bodies (ISO member bodies). The work of preparing International Standards is normally carried out through ISO technical committees. Each member body interested in a subject for which a technical committee has been established has the right to be represented on that committee. International organizations, governmental and non-governmental, in liaison with ISO, also take part in the work. ISO collaborates closely with the International Electrotechnical Commission (IEC) on all matters of electrotechnical standardization.

Draft International Standards adopted by the technical committees are circulated to the member bodies for voting. Publication as an International Standard requires approval by at least 75 % of the member bodies casting a vote.

International Standard ISO 4412-3 was prepared jointly by Technical Committees ISO/TC 131, *Fluid power systems*, Sub-Committee SC 8, *Product testing and contamination control* and ISO/TC 43, *Acoustics*.

ISO 4412 consists of the following parts, under the general title *Hydraulic fluid power — Test code for determination of airborne noise levels*:

- Part 1: *Pumps*
- Part 2: *Motors*
- Part 3: *Pumps — Method using a parallelepiped microphone array*

Annex A forms an integral part of this part of ISO 4412. Annex B is for information only.

Introduction

In hydraulic fluid power systems, power is transmitted and controlled through a liquid under pressure in a closed circuit. Pumps are components which convert rotary mechanical power into fluid power. During the process of converting mechanical power into hydraulic fluid power, airborne noise, fluid-borne vibrations and structure-borne vibrations are radiated from the pump.

The airborne noise level of a hydraulic fluid power pump is an important consideration in component selection. The noise measurement technique should, therefore, be such as to yield accurate appraisals of these airborne noise levels. The determination of noise levels is complicated by the interactions which occur during noise measurements. The fluid-borne and structure-borne vibrations from the pump can be transmitted to the circuit and ultimately give rise to background airborne noise levels which could affect the determination of the pump airborne noise levels.

The procedures described in this part of ISO 4412 are intended to measure only the airborne noise radiated directly from the pump under test.

This part of ISO 4412 closely follows the methods described in the two other parts, but allows the use of alternative pump mounting and drive configurations which are simpler and cheaper to implement in an anechoic chamber. Much of the guidance given in ISO 4412-1:1991, annex C, is equally applicable to this part of ISO 4412. The data obtained have been shown to be sufficiently accurate in engineering terms for A-weighted and one-third octave noise measurements, in decibels.

This part of ISO 4412 may also be applied to the testing of motors.

Hydraulic fluid power — Test code for determination of airborne noise levels —

Part 3:

Pumps — Method using a parallelepiped microphone array

1 Scope

This part of ISO 4412 describes procedures for the determination of the sound power levels of a hydraulic fluid power pump, under controlled conditions of installation and operation, suitable for providing a basis for comparing the noise levels of pumps in terms of

- A-weighted sound power level;
- one-third octave band power level.

From these sound power levels, if required, reference sound pressure levels may be calculated for reporting purposes (see clause 11).

For general purposes, the frequency range of interest includes the one-third octave bands with centre frequencies between 100 Hz and 10 000 Hz.¹⁾

This part of ISO 4412 is applicable to all types of hydraulic fluid power pumps operating under steady-state conditions, irrespective of size, except for any limitations imposed by the size of the test environment (see clause 3).

2 Normative references

The following standards contain provisions which, through reference in this text, constitute provisions of this part of ISO 4412. At the time of publication, the editions indicated were valid. All standards are subject to revision, and parties to agreements based on this part of ISO 4412 are encouraged to investigate the possibility of applying the most recent editions of the standards indicated below. Members of

IEC and ISO maintain registers of currently valid International Standards.

ISO 3448:1975, *Industrial liquid lubricants — ISO viscosity classification*.

ISO 3744:1981, *Acoustics — Determination of sound power levels of noise sources — Engineering methods for free-field conditions over a reflecting plane*.

ISO 5598:1985, *Fluid power systems and components — Vocabulary*.

ISO 6743-4:1982, *Lubricants, industrial oils and related products (class L) — Classification — Part 4: Family H (Hydraulic systems)*.

IEC 651:1979, *Sound level meters*.

3 Definitions

For the purposes of this part of ISO 4412, the definitions given in ISO 5598 and the following definitions apply. It is accepted that the latter definitions may differ from those in other specific International Standards.

3.1 free sound field: Sound field in a homogeneous, isotropic medium free of boundaries.

NOTE 1 In practice, it is a field in which the effects of the boundaries are negligible over the frequency range of interest.

3.2 free field over two reflecting planes: Field produced by a source in the presence of two mutually perpendicular reflecting planes.

1) 1 Hz = 1 s⁻¹

ISO 4412-3:1991(E)

3.3 anechoic room: Test room having boundaries which absorb essentially all of the incident sound energy over the frequency range of interest, thereby affording free-field conditions over the measurement surface.

3.4 mean-square sound pressure: The sound pressure averaged in space and time on a mean-square basis.

NOTE 2 In practice, this is estimated by space and time averaging over a finite path length or over a number of fixed microphone positions.

3.5 mean sound pressure level (L_p): Ten times the logarithm to the base 10 of the ratio of the mean-square sound pressure to the square of the reference sound pressure, in decibels (dB).

NOTE 3 The weighting network or the width of the frequency band used should always be indicated; for example, A-weighted sound pressure level, octave band sound pressure level. The reference sound pressure is 20 μPa ²⁾.

3.6 sound power level L_{wp} : Ten times the logarithm to the base 10 of the ratio of a given sound power to the reference sound power, in decibels (dB).

NOTE 4 The weighting network or the width of the frequency band used should always be indicated. The reference sound power is 1 pW³⁾.

3.7 volume of source under test: Volume of the envelope of the whole pump under test.

3.8 reference box: Hypothetical reference surface which is the smallest rectangular parallelepiped that just encloses the pump and any large directly-attached appendages (such as valve bodies or control handwheels) and which terminates on the reflecting planes.

4 Measurement uncertainty

With the exception of the measurement environment specified in clause 5, use methods of measurement which tend to result in standard deviations which are equal to or less than those given in table 1. To meet this requirement, use the engineering methods given in ISO 3744: 1981, clause 4 and annex A.

Table 1 — Standard deviations of sound power level determinations

Standard deviation, dB, for one-third octave band centre frequencies			
100 Hz to 160 Hz	200 Hz to 630 Hz	800 Hz to 5 000 Hz	6 300 Hz to 10 000 Hz
5,0	3,0	2,0	3,0

The standard deviations given in table 1 include the effects of allowable variations in the positioning of the measurement points and in the selection of any prescribed measurement surface, but exclude variations in the sound power output of the source from test to test.

NOTE 5 The A-weighted sound power level will in most practical cases be determined with a standard deviation of approximately 2 dB.

5 Test environment

Tests shall be conducted in an environment generally in accordance with that described in ISO 3744 and which provides free-field conditions over two mutually perpendicular reflecting planes, both of which extend beyond the projected area of the microphone measuring array.

Calibrate the acoustic test environment thus formed and ascertain the environmental corrections for each frequency band of interest, using the procedures described in ISO 3744:1981, annex A.

6 Instrumentation

6.1 The instrumentation used to measure fluid flow, fluid pressure, pump speed and fluid temperature shall be in accordance with the recommendations for "Industrial class" accuracy of testing; i.e. class C given in annex A.

6.2 The instrumentation used for acoustical measurements shall be in accordance with IEC 651. This instrumentation shall be in accordance with ISO 3744 for both performance and calibration; i.e. type 2 instruments for engineering (grade 2) measurements.

2) 1 μPa = 10^{-6} N/m²

3) 1 pW = 10^{-12} W

7 Installation conditions

7.1 Pump location

The pump shall be located with its mounting flange flush with one reflecting plane. The second reflecting plane shall be arranged so as to intersect the first at right angles as close to the pump as practicable.

7.2 Pump mounting

7.2.1 The pump mounting shall be constructed so that it will minimize the noise radiated as a result of pump vibrations.

7.2.2 The mounting bracket shall be constructed of high damping material, or with sound-damping and sound-insulating material applied to the bracket as required.

7.2.3 Vibration isolation techniques, if needed, shall be used even if the pump is usually securely mounted.

7.3 Pump drive

The drive motor shall be located outside the test space and the pump shall be driven through flexible couplings and an intermediate shaft, or the motor shall be isolated in an acoustic enclosure.

7.4 Hydraulic circuit

7.4.1 The circuit shall include all oil filters, oil coolers, reservoirs and restrictor valves as required to meet the pump hydraulic operating conditions (see clause 8).

7.4.2 The test fluid and degree of filtration shall be in accordance with the manufacturer's recommendations.

7.4.3 Inlet and discharge lines shall be installed with diameters in accordance with the manufacturers' recommended practice. Extra care shall be exercised when assembling inlet lines to prevent air leaking into the circuit.

7.4.4 The inlet pressure gauge shall be mounted at the same height as the inlet fittings or it shall be calibrated for any height difference.

7.4.5 The length of line between the pump and the load valve shall be selected in order to minimize the effect of standing waves in the discharge line which can increase the sound radiated from the pump. At

least 15 m of hose shall be used to meet this requirement.

7.4.6 A stable load valve shall be used.

NOTE 6 Unstable load valves in the discharge line can generate and transmit noise through the fluid and piping which can emerge as airborne sound at the pump.

7.4.7 The load valve shall be positioned as far as possible from the pump; preferably outside the test room, to minimize interaction. The load valve shall be located close to the pump only when adequate control of its acoustic performance can be provided.

7.4.8 All fluid lines and load valves in the test space shall be wrapped with sound-isolating materials, if required (see 10.1). Material having a sound-transmission loss of at least 10 dB at 125 Hz, and a greater loss at higher frequencies, shall be used.

8 Operating conditions

8.1 Determine the sound power levels of the pump (see clause 11) for any desired set of operating conditions (see 12.3.7).

8.2 These test conditions shall be maintained throughout the test within the limits given in table 2.

Table 2 — Allowable variations of mean indicated values of controlled parameters

Test parameter	Allowable variation
Flow	±2 %
Pressure	±2 %
Speed	±2 %
Temperature	±2 °C

8.3 The pump shall be tested in the "as-delivered" condition with any ancillary pumps and valves operating normally during the test, so as to include their noise contributions to the airborne noise level of the pump.

9 Location and number of sound measurement points

Provide and locate six measuring microphones in a parallelepiped array, in accordance with figure 1, and having the coordinates listed in table 3. Centre the array at the intersection of the two reflecting planes, on the projected centreline of the pump.

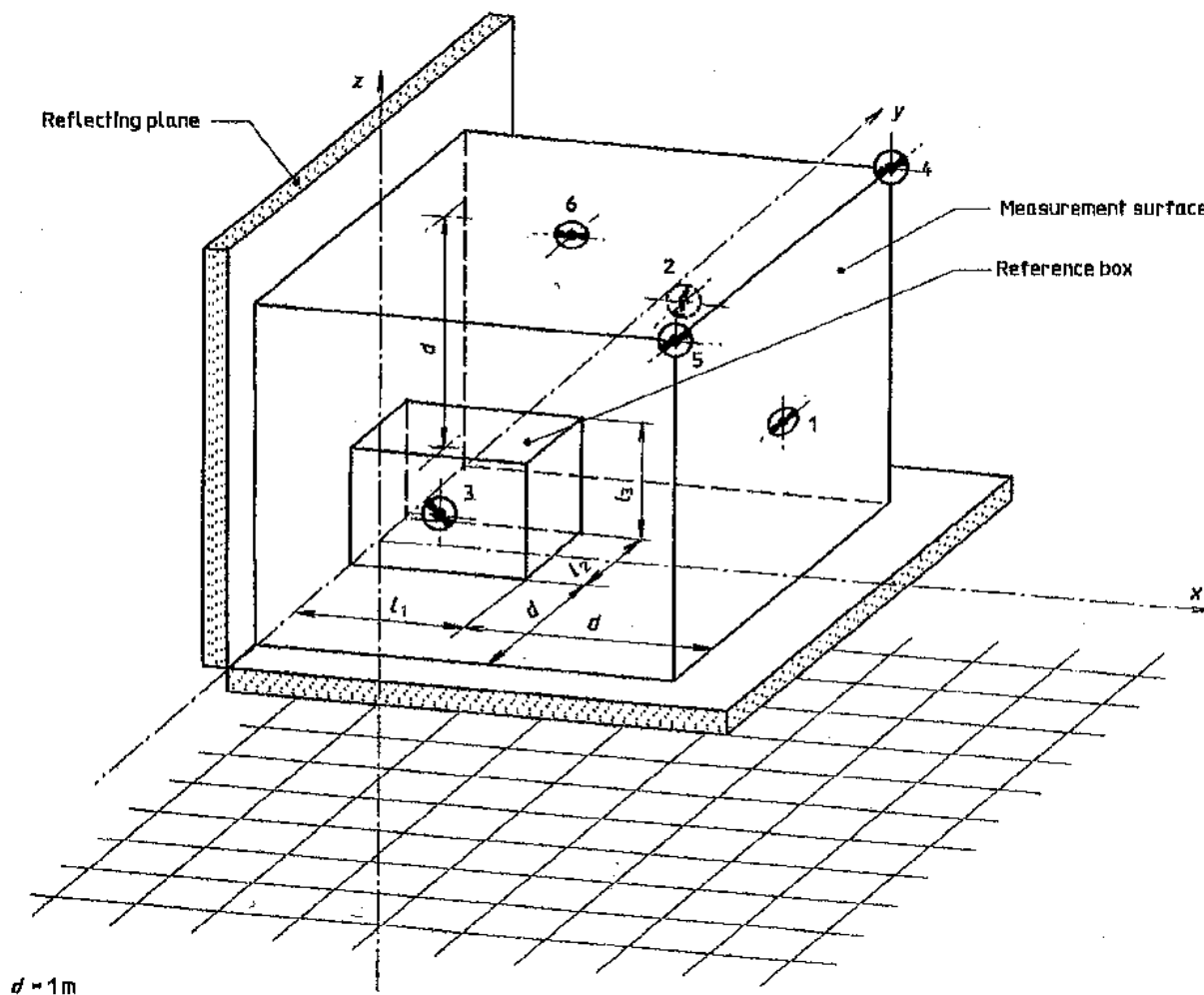

$d = 1\text{m}$

NOTE - This form of array is based upon the microphone array described in ISO 3744:1981, annex C.

Figure 1 — Microphone array on rectangular parallelepiped measuring surface

10 Test procedure

Table 3 — Coordinates of microphone locations shown in figure 1

Microphone position	Coordinates		
	x	y	z
1	$l_1 + d$	0	$\frac{l_3 + d}{2}$
2 and 3	$\frac{l_1 + d}{2}$	$\pm\left(\frac{l_2}{2} + d\right)$	$\frac{l_3 + d}{2}$
4 and 5	$l_1 + d$	$\pm\left(\frac{l_2}{2} + d\right)$	$l_3 + d$
6	$\frac{l_1 + d}{2}$	0	$l_3 + d$

10.1 Background noise measurements

10.1.1 Measure the background noise of interest that is present during the pump noise test which does not emanate from the pump itself.

Over the frequency range of interest, the band sound pressure levels of this background noise shall be at least 6 dB below the pump band sound pressure levels at each measurement point.

10.1.2 Correct for this background noise, if evidenced by these measurements, by applying the corrections for this purpose given in ISO 3744.

10.1.3 When measurement of band levels of background noise is not practical, the A-weighted background sound level of each measurement point shall be at least 8 dB below the pump A-weighted sound level.

Correct these A-weighted measurements for background noise.

NOTES

7 Easing the requirements for background noise levels can lead to an overestimate of the pump band sound pressure levels.

8 The A-weighted background sound level at each measurement point may be checked by covering the pump with sound-insulating materials capable of a transmission loss of at least 10 dB over the frequency range which is "determining" the A-weighted sound level of the pump.

10.1.4 If the background level is found to be too high, check for further noise control of the pump mounting, drive or hydraulic circuit, as indicated.

10.1.5 Ensure that the orientation of the microphones and the period of observation are as specified in ISO 3744.

10.2 Pump measurements

10.2.1 Measurement sequence

Prior to commencement of a series of tests, operate the pump for a sufficient time to purge air from the system and to stabilize all variables, including fluid condition, to within the limits given in table 2.

Measure the following for each test:

- a) pump speed and flow rate;
- b) fluid temperature and pressure at pump inlet and fluid pressure at discharge fittings or at the test point provided by the pump manufacturer;
- c) band sound pressure levels at each measurement point over the frequency range of interest;
- d) A-weighted sound pressure level at each measurement point, if required.

10.2.2 New or rebuilt pumps

10.2.2.1 Repeat the initial pump measurement test of the series at the end of a test series or after 1 h of testing.

10.2.2.2 If the A-weighted sound level at any selected measurement point does not duplicate that of the first test within 2 dB (A), the whole test series shall be invalidated.

11 Calculation of surface sound pressure levels and sound power levels

Calculate the sound pressure levels and sound power levels as described in ISO 3744. The surface area, S , used in ISO 3744:1981, 8.3 shall be calculated as follows:

$$S = 2(l_1 + d)(l_3 + d) + (l_2 + 2d)(l_3 + d) + (l_1 + d)(l_2 + 2d)$$

where l_1 , l_2 and l_3 are the dimensions of the reference box shown in figure 1, and $d = 1$ m.

12 Information to be recorded

12.1 Specifications

The information given in 12.2 and 12.3 shall be compiled and recorded for all measurements made according to the requirements of this part of ISO 4412.

12.2 General information

- a) name and address of pump manufacturer and, if applicable, user;
- b) reference number(s) for identification of the pump;
- c) name and address of persons or organization responsible for the acoustic tests on the pump;
- d) date and place of acoustic tests;
- e) a statement that the sound power levels of the pump have been obtained in full conformance with this part of ISO 4412.

12.3 Pump under test

12.3.1 Description of pump

- a) type of pump (e.g. gear or piston), including ancillary equipment;
- b) type of displacement (e.g. fixed or variable);
- c) pump overall linear dimensions (with sketch if necessary);
- d) pump maximum displacement;
- e) type of displacement controller and setting.

ISO 4412-3:1991(E)

12.3.2 Acoustic environment for tests

- a) the internal dimensions of the test room and the type of acoustic field for the measurements (e.g. free field over two reflecting planes);
- b) the acoustical treatment of the test room;
- c) the date of measurement;
- d) ambient temperature (in degrees Celsius), relative humidity (in percentage) and barometric pressure (in pascals⁴⁾;
- e) results of acoustical qualification of test environment, as required by ISO 3744.

12.3.3 Reference sound source

- a) manufacturer, type and serial number;
- b) sound power level calibration data, including name of calibrating laboratory and date of calibration.

12.3.4 Mounting and installation conditions of pump

- a) description of pump mounting conditions;
- b) nature and characteristics of hydraulic circuit and details of any acoustic insulation treatment;
- c) nature and description of other machines being used which could have an influence on the measured sound pressure levels of the pump.

12.3.5 Location of pump in test environment

12.3.5.1 Include a sketch showing the location of the pump in relation to walls, floor and ceiling of test room.

12.3.5.2 Show on this sketch the location of other reflecting or absorbing screens and noise sources which can influence measurements.

12.3.6 Instrumentation

- a) details of equipment used to monitor pump operating conditions (see 12.3.7) including type, serial number and manufacturer;

- b) details of equipment used for acoustic measurements including name, type, serial number and manufacturer;
- c) bandwidth of frequency analyser;
- d) overall frequency response of instrumentation system and date and method of calibration;
- e) method of calibration of microphones and date and place of calibration.

12.3.7 Pump operating conditions

Include the following details for each test:

- a) full description of fluid, including classification in accordance with ISO 6743-4;
- b) fluid viscosity classification in accordance with ISO 3448, in centistokes or in millimetres squared per second⁵⁾;
- c) shaft speed, in revolutions per minute;
- d) inlet pressure, in megapascals (bars⁶⁾);
- e) outlet pressure, in megapascals (bars);
- f) pump delivery (flow), either measured or calculated, in litres per minute;
- g) temperature of fluid at pump inlet, in degrees Celsius.

12.3.8 Acoustical data

Include all data as required by ISO 3744.

13 Test report

The test report shall contain the following information:

- a) the A-weighted sound power level and one-third octave band sound power levels for each frequency band of interest for each set of operating conditions;
- b) a statement that the sound power levels have been obtained in full conformance with the procedures of this part of ISO 4412 and the specified paragraphs of ISO 3744 for the determination of sound power levels of noise sources.

4) $1 \text{ Pa} = 10^{-5} \text{ bar}$

5) $1 \text{ cSt} = 1 \text{ mm}^2/\text{s}$

6) $1 \text{ bar} = 10^5 \text{ N/m}^2 = 10^5 \text{ Pa} = 0,1 \text{ MPa}$

14 Identification statement (Reference to this part of ISO 4412)

Use the following statement in test reports, catalogues and sales literature when complying with this part of ISO 4412:

"Airborne noise levels determined in accordance with ISO 4412-3, *Hydraulic fluid power — Test code for determination of airborne noise levels — Part 3: Pumps — Method using a parallelepiped microphone array.*"

Annex A (normative)

Errors and classes of measurement

A.1 Classes of measurement

Depending on the accuracy required, the tests may be carried out to one of three classes of measurement, A, B or C. The classes of measurement shall be agreed between the parties concerned. The use of class A and class B is restricted to special cases where there is a need to have the performance more precisely defined. Such tests require more accurate apparatus and methods, possibly increasing the costs of such tests. This part of ISO 4412, however, specifies class C accuracy.

A.2 Errors

Use any device or method that by calibration or comparison with International Standards has been demonstrated to be capable of measuring with systematic errors not exceeding the limits given in table A.1.

Table A.1 — Permissible systematic errors of measuring instruments as determined during calibration

Class of measurement	Units	A (see A.1)	B (see A.1)	C
Flow	%	$\pm 0,5$	$\pm 1,5$	$\pm 2,5$
Pressure	%	$\pm 0,5$	$\pm 1,5$	$\pm 2,5$
Temperature	°C	$\pm 0,5$	$\pm 1,0$	$\pm 2,0$
Speed	%	$\pm 0,5$	$\pm 1,0$	$\pm 2,0$

NOTE — The percentage limits are of the value of the quantity being measured and not of the maximum values of the test or the maximum reading of the instrument.

Annex B
(informative)

Bibliography

- [1] ISO 4412-1:1991, *Hydraulic fluid power — Test code for determination of airborne noise levels — Part 1: Pumps.*
- [2] ISO 4412-2:1991, *Hydraulic fluid power — Test code for determination of airborne noise levels — Part 2: Motors.*

ISO 4412-3:1991(E)

UDC 621.65:534.6

Descriptors: hydraulic fluid power, acoustics, hydraulic equipment, pumps, tests, acoustic tests, determination, noise (sound), airborne sound, acoustic measurements.

Price based on 0 pages
