**Hydraulic fluid power — Valves —
Determination of pressure
differential/flow characteristics**

*Transmissions hydrauliques — Distributeurs — Détermination des
caractéristiques de pression différentielle/débit*



Reference number
ISO 4411:2008(E)

© ISO 2008

PDF disclaimer

This PDF file may contain embedded typefaces. In accordance with Adobe's licensing policy, this file may be printed or viewed but shall not be edited unless the typefaces which are embedded are licensed to and installed on the computer performing the editing. In downloading this file, parties accept therein the responsibility of not infringing Adobe's licensing policy. The ISO Central Secretariat accepts no liability in this area.

Adobe is a trademark of Adobe Systems Incorporated.

Details of the software products used to create this PDF file can be found in the General Info relative to the file; the PDF-creation parameters were optimized for printing. Every care has been taken to ensure that the file is suitable for use by ISO member bodies. In the unlikely event that a problem relating to it is found, please inform the Central Secretariat at the address given below.



COPYRIGHT PROTECTED DOCUMENT

© ISO 2008

All rights reserved. Unless otherwise specified, no part of this publication may be reproduced or utilized in any form or by any means, electronic or mechanical, including photocopying and microfilm, without permission in writing from either ISO at the address below or ISO's member body in the country of the requester.

ISO copyright office
Case postale 56 • CH-1211 Geneva 20
Tel. + 41 22 749 01 11
Fax + 41 22 749 09 47
E-mail copyright@iso.org
Web www.iso.org

Published in Switzerland

Foreword

ISO (the International Organization for Standardization) is a worldwide federation of national standards bodies (ISO member bodies). The work of preparing International Standards is normally carried out through ISO technical committees. Each member body interested in a subject for which a technical committee has been established has the right to be represented on that committee. International organizations, governmental and non-governmental, in liaison with ISO, also take part in the work. ISO collaborates closely with the International Electrotechnical Commission (IEC) on all matters of electrotechnical standardization.

International Standards are drafted in accordance with the rules given in the ISO/IEC Directives, Part 2.

The main task of technical committees is to prepare International Standards. Draft International Standards adopted by the technical committees are circulated to the member bodies for voting. Publication as an International Standard requires approval by at least 75 % of the member bodies casting a vote.

Attention is drawn to the possibility that some of the elements of this document may be the subject of patent rights. ISO shall not be held responsible for identifying any or all such patent rights.

ISO 4411 was prepared by Technical Committee ISO/TC 131, *Fluid power systems*, Subcommittee SC 5, *Control products and components*.

This second edition cancels and replaces the first edition (ISO 4411:1986), which has been technically revised.

Introduction

In hydraulic fluid power systems, power is transmitted and controlled through a liquid under pressure within an enclosed circuit. Hydraulic valves control the direction, pressure or flow rate of the fluid in the system.

When fluid flows through a valve, it encounters some resistance, which results in a loss of pressure; this loss is called the pressure differential.

This International Standard is intended to unify testing methods for hydraulic fluid power valves to enable the pressure differential/flow characteristics of different valves to be compared.

Hydraulic fluid power — Valves — Determination of pressure differential/flow characteristics

1 Scope

This International Standard specifies methods for determining, under steady-state conditions, the pressure differential caused by the flow through any given path in a hydraulic fluid power valve. Requirements for test installations, procedures and presentation of results are specified.

2 Normative references

The following referenced documents are indispensable for the application of this document. For dated references, only the edition cited applies. For undated references, the latest edition of the referenced document (including any amendments) applies.

ISO 1219-1, *Fluid power systems and components — Graphic symbols and circuit diagrams — Part 1: Graphic symbols for conventional use and data-processing applications*

ISO 4401, *Hydraulic fluid power — Four-port directional control valves — Mounting surfaces*

ISO 5598¹⁾, *Fluid power systems and components — Vocabulary*

ISO 5781, *Hydraulic fluid power — Pressure-reducing valves, sequence valves, unloading valves, throttle valves and check valves — Mounting surfaces*

ISO 6263, *Hydraulic fluid power — Compensated flow-control valves — Mounting surfaces*

ISO 6264, *Hydraulic fluid power — Pressure-relief valves — Mounting surfaces*

ISO 9110-1, *Hydraulic fluid power — Measurement techniques — Part 1: General measurement principles*

ISO 9110-2, *Hydraulic fluid power — Measurement techniques — Part 2: Measurement of average steady-state pressure in a closed conduit*

ISO 10372, *Hydraulic fluid power — Four- and five-port servovalves — Mounting surfaces*

3 Terms and definitions

For the purposes of this document, the terms and definitions given in ISO 5598 and the following apply.

3.1

tare pressure differential

pressure loss between the pressure-tapping points as generated by the test equipment exclusive of the test valve

1) To be published. (Revision of ISO 5598:1985)

3.2 measured pressure differential
 measured pressure loss between the pressure-tapping points, including the pressure loss through the test valve and the test equipment

3.3 flow rate
 q_V
 volume rate of flow at the point of measurement

3.4 pressure differential
 Δp
 pressure loss attributed to the test valve

4 Symbols and units

4.1 The symbols and units used throughout this International Standard are shown in Table 1.

4.2 The graphical symbols used in Figures 1 to 3 are in accordance with ISO 1219-1.

Table 1 — Symbols and units

Reference subclause	Quantity	Symbol	Dimension ^a	Unit ^b
3.3	Volume flow rate	q_V	L^3T^{-1}	m ³ /s
3.4	Pressure differential	Δp	$ML^{-1}T^{-2}$	Pa ^c
—	Inside diameter of tube	d	L	m
—	Temperature	θ	Θ	°C
—	Kinematic viscosity	ν	L^2T^{-1}	m ² /s
—	Mass density	ρ	ML^{-3}	kg/m ³

^a M signifies mass, L signifies length, T signifies time.

^b The use of practical units for the presentation of results is described in Annex A.

^c 1 Pa = 1 N/m².

5 Test installations

NOTE Annex B provides a checklist for the selection of appropriate items upon which agreement between the parties concerned is recommended prior to testing.

5.1 Selection, calibration and installation of equipment

5.1.1 Equipment shall be selected in accordance with ISO 9110-2.

5.1.2 Calibration shall be carried out in accordance with ISO 9110-1.

5.1.3 The test set-up shall be in accordance with ISO 9110-2.

5.2 Test circuit

5.2.1 A circuit suitable for testing valves as shown in Figure 1 shall be used. The requirements for the position of the pressure-measuring connections and the flow meter shown in Figure 1 and referred to in 5.2.5 through 5.2.9 apply only to Class A measurement accuracy.

Figure 1 illustrates a basic circuit that does not incorporate all the safety devices necessary to protect against damage in the event of component failure. It is important that those responsible for carrying out the test give due consideration to safeguarding both personnel and equipment.

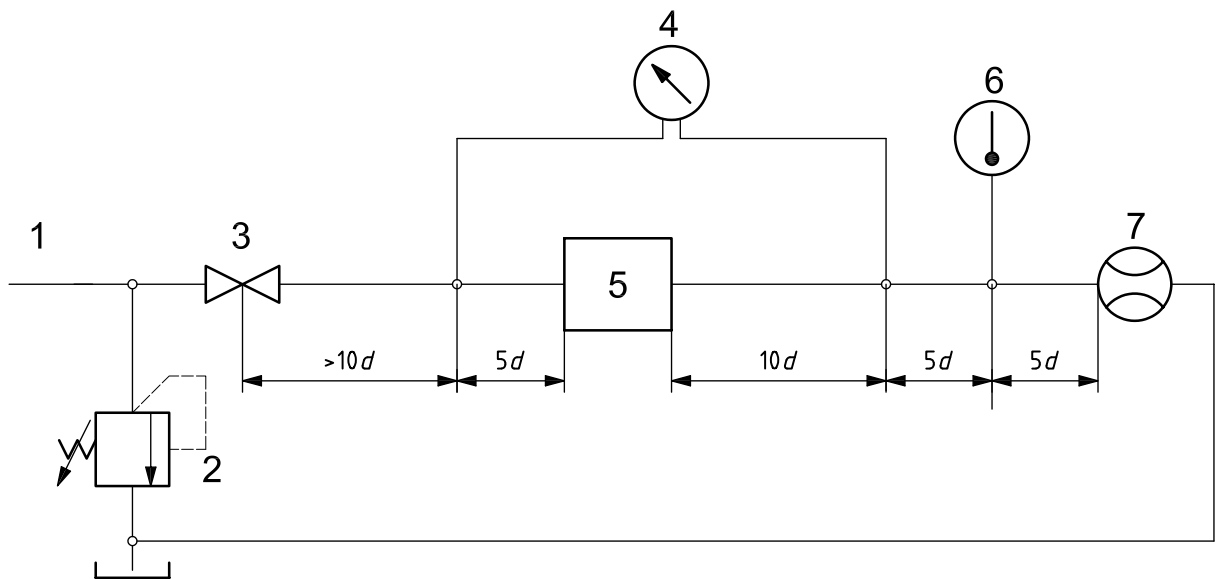

Key

- 1 controllable flow supply, at controlled fluid temperature
- 2 relief valve (circuit protection)
- 3 stop valve (normally fully open)
- 4 pressure differential measuring device
- 5 test valve
- 6 temperature measuring device
- 7 flow meter

Figure 1 — Test circuit diagram

5.2.2 On subplate-mounted valves and sandwich-mounted valves, measurements should be carried out using standard pressure-tapping plates (intermediate plates) as shown in Figure 2. In this case, the requirements given in 5.2.5 through 5.2.8 and 5.3 do not apply.

Dimension *A* shall be the maximum port size specified in ISO 4401, ISO 5781, ISO 6263, ISO 6264 or ISO 10372 for the valve being tested.

Dimension *B* shall be appropriate for the selected interface O-ring.

The threaded port size shall be appropriate for the flow rating of the valve.

Only one port is shown, which would be typical for P, T, A and B ports.

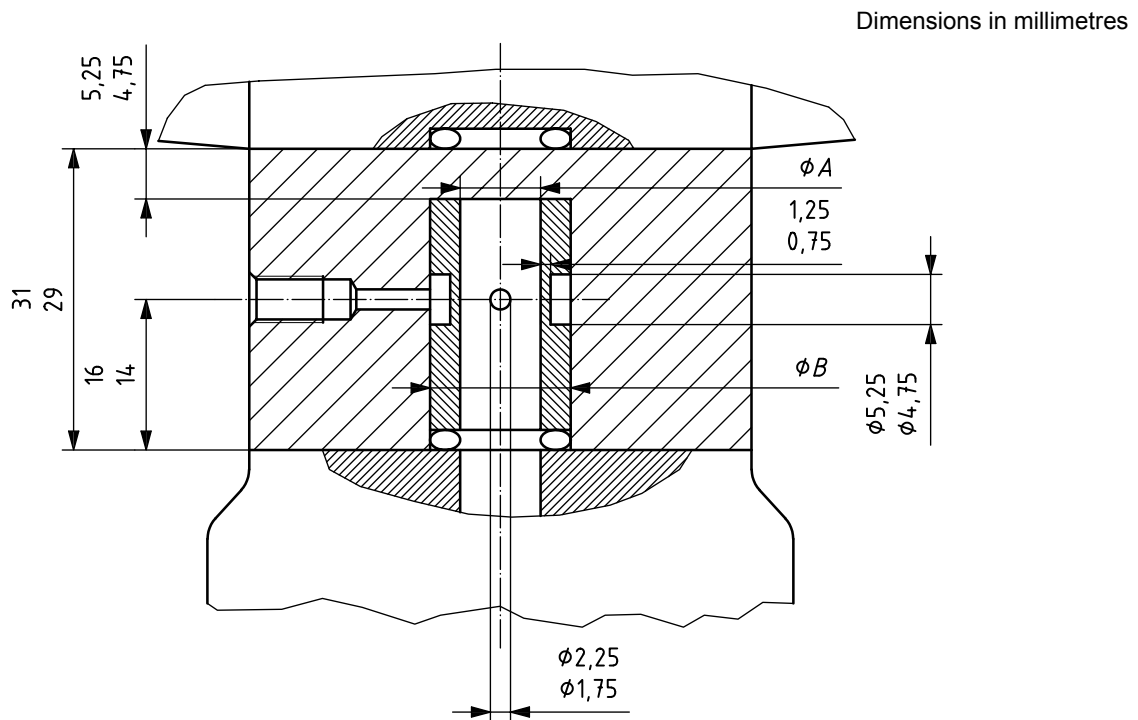

Figure 2 — Standard pressure-tapping plate for subplate-mounted valves

5.2.3 A fluid supply with controllable flow shall be used.

5.2.4 A relief valve shall be installed to protect the circuit from excessive pressure.

5.2.5 To establish a steady flow pattern at the upstream tapping, a visibly straight, uniform-bore tube length of at least $10d$ shall be used.

5.2.6 A visibly straight, uniform-bore tube length of at least $5d$ shall be used between the upstream and downstream pressure tapping and the valve.

5.2.7 To ensure adequate pressure recovery, a visibly straight, uniform-bore tube length of at least $10d$ shall be used between the test valve and the downstream pressure tapping.

5.2.8 A visibly straight, uniform-bore tube length of at least $5d$ shall be used between the downstream pressure tapping and the temperature measuring point.

5.2.9 A flow meter shall be installed to measure the flow rate at a point at least $5d$ downstream of the tube length described in 5.2.8. Turbines or thermal meters that do not contain flow straighteners should be installed at least $10d$ downstream.

5.2.10 Tubes and connectors consistent with the port size of the valve shall be used.

5.3 Pressure-tapping points

5.3.1 Static pressure measuring connections shall be used in accordance with ISO 9110-2.

5.3.2 For all classes of measurement accuracy, single pressure tapping shall be used.

5.3.3 Tapping shall not be installed on the lowest point of the tube.

6 Test procedures

6.1 Measurement accuracy

The test shall be carried out to one of three classes of measurement, A, B or C, as defined in ISO 9110-1. The measurement class shall be as agreed between the parties concerned. Permissible systematic errors for the measurement classes shall be as shown in Table 2.

Table 2 — Permissible systematic errors of measuring instruments as determined during calibration

Parameter of measuring instrument	Permissible systematic errors for classes of measurement accuracy		
	A	B	C
Flow rate, q , expressed in percent	$\pm 1,0$	$\pm 2,0$	$\pm 3,0$
Differential pressure, Δp , expressed in percent	$\pm 1,0$	$\pm 3,0$	$\pm 5,0$
Temperature, expressed in kelvins	$\pm 0,5$	$\pm 1,0$	$\pm 2,0$

6.2 Test fluid

6.2.1 A test fluid approved by the manufacturer of the valve shall be used when carrying out the tests. A description of the fluid shall be recorded, and its mass density, ρ , and kinematic viscosity, ν , for the range of temperature used in the test shall be stated.

6.2.2 The fluid cleanliness level shall be maintained within the limits recommended by the valve manufacturer.

6.2.3 For class A or B measurement accuracy, the mass density, ρ , and the kinematic viscosity, ν , from fluid samples taken from the test installation shall be measured immediately before the test.

6.2.4 For class C measurement accuracy, it is permissible to use density and viscosity data obtained from the fluid supplier.

6.3 Temperatures

6.3.1 The fluid temperature shall be controlled during the test within the limits specified in Table 3.

Table 3 — Permissible variation in indicated fluid temperature

Class of measurement accuracy	A	B	C
Variation in temperature indication, expressed in kelvins	$\pm 1,0$	$\pm 2,0$	$\pm 4,0$

6.3.2 The test shall be carried out within the range of fluid temperatures recommended by the valve manufacturer for the intended application of the valve.

6.4 Steady-state conditions

6.4.1 All readings shall only be recorded after steady-state conditions have been reached.

6.4.2 When steady-state conditions are reached for a specific test condition, only one set of readings of individual quantities shall be taken over concurrent common time periods. Each reading shall be recorded as the mean value of each quantity being measured.

6.5 Procedure

6.5.1 Install the test valve in the test circuit using the upstream and downstream ports in the valve or in the tapping plate as required.

6.5.2 Set the valve control for the flow path (or flow rate) required, if applicable.

6.5.3 The number of sets of readings to be taken and their distribution over the range shall be selected to give a representative indication of the performance of the valve over the full range of flow selected for the test.

6.5.4 For each flow selected in 6.5.3, measure the upstream pressure and the downstream pressure. If the test valve is a subplate-mounted type, skip 6.5.5 and 6.5.6.

6.5.5 If the test valve is a line-mounted type, remove it from the test circuit and connect the lines as specified in 6.5.1 to complete the test circuit without the test valve. This step is not necessary when a test circuit in accordance with 5.2.2 is used.

6.5.6 Repeat the pressure measurements of 6.5.4.

6.6 Pressure differential calculation

6.6.1 Where appropriate, correct each pressure reading for pressure head effects in accordance with ISO 9110-2.

6.6.2 Calculate the measured pressure differential for each reading in 6.5.4 by subtracting the downstream pressure from the upstream pressure. If the test valve is a subplate-mounted type, skip 6.6.3 and 6.6.4.

6.6.3 If the test valve is a line-mounted type, calculate the tare pressure differential for each reading in 6.5.6 by subtracting the downstream pressure from the upstream pressure. Use a value of zero when a test circuit in accordance with 5.2.2 is used.

6.6.4 If the test valve is a line-mounted type, calculate the pressure differential, Δp , for each reading by subtracting the tare pressure differential obtained in 6.6.3 from the measured pressure differential obtained in 6.6.2.

6.7 Presentation of the test results

6.7.1 General

All test measurements and the results of calculations therefrom shall be tabulated by the testing agency and preferably also presented graphically as described in 6.7.2.

6.7.2 Presentation

The test results shall be presented dimensionally as a graph of pressure differential, Δp , against the flow rate, q_V . See Annex A for practical units. The kinematic viscosity and mass density at the controlled fluid temperature shall also be stated. An example is shown in Figure 3.

For pilot check-valve cartridges, pilot relief valves or multifunctional valves with external drains, it is important to ensure that the characteristics are system independent and generally valid.

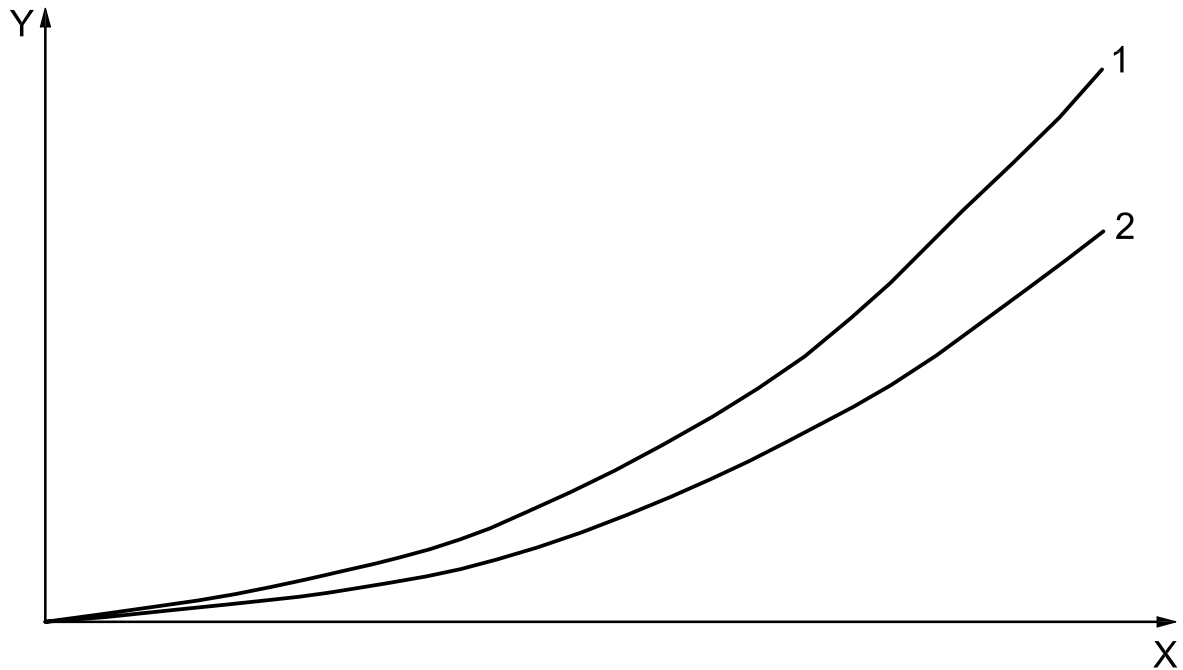

Valve manufacturer:
 Valve type:
 Valve model:
 Test fluid:
 Fluid kinematic viscosity:
 Fluid mass density:
 Fluid temperature:
 Measurement class:
 Valve state:

Key

X volume flow rate, q_V
 Y differential pressure, Δp
 1 flow path from B working port to T port
 2 flow path from P port to A working port

Figure 3 — Example of the presentation of test results

7 Identification statement (reference to this International Standard)

It is strongly recommended to manufacturers who have chosen to conform to this International Standard that the following statement be used in test reports, catalogues and sales literature:

“Test for the determination of pressure differential/flow characteristics of hydraulic valves conforms to ISO 4411:2008, *Hydraulic fluid power — Valves — Determination of pressure differential/flow characteristics.*”

Annex A (normative)

Use of practical units

The results of tests in either tabular or graphical form may be presented using practical units as given in Table A.1.

Table A.1 — Practical units

Quantity	Symbol	Practical unit
Nominal diameter of valve	D	mm
Volume flow rate	q_V	l/min
Pressure differential	Δp	kPa (bar)
Tube length	l	m
Inside diameter of tube	d	mm
Temperature	θ	°C
Kinematic viscosity	ν	mm ² /s (cSt)
Mass density	ρ	kg/m ³

Annex B (informative)

Pre-test checklist

The following list constitutes a checklist for the selection of appropriate items upon which agreement is recommended between the parties concerned prior to testing.

- a) valve manufacturer's name;
- b) manufacturer's identification (type number, serial number);
- c) manufacturer's description of valve;
- d) valve port sizes;
- e) test circuit (see 5.2.1);
- f) inside diameter of tube;
- g) pressure-tapping positions (see 5.3);
- h) cleanliness level of test fluid (see 6.2.2);
- i) test fluid (by name and description) (see 6.2.1);
- j) test fluid kinematic viscosity at test temperature (see 6.2.1 and 6.2.4);
- k) test fluid mass density at test temperature (see 6.2.1 and 6.2.4);
- l) test fluid temperature during test (see 6.3);
- m) range of flow for test (see 6.5.3);
- n) presentation of test results (see 6.7 and Annex A);
- o) class of measurement accuracy (see 6.1).

ICS 23.100.50

Price based on 9 pages