**Petroleum and related products —
Determination of the corrosion resistance
of fire-resistant hydraulic fluids —**

**Part 2:
Non-aqueous fluids**

*Pétrole et produits connexes — Détermination de la résistance à la
corrosion de fluides hydrauliques difficilement inflammables —*

Partie 2: Fluides non aqueux



PDF disclaimer

This PDF file may contain embedded typefaces. In accordance with Adobe's licensing policy, this file may be printed or viewed but shall not be edited unless the typefaces which are embedded are licensed to and installed on the computer performing the editing. In downloading this file, parties accept therein the responsibility of not infringing Adobe's licensing policy. The ISO Central Secretariat accepts no liability in this area.

Adobe is a trademark of Adobe Systems Incorporated.

Details of the software products used to create this PDF file can be found in the General Info relative to the file; the PDF-creation parameters were optimized for printing. Every care has been taken to ensure that the file is suitable for use by ISO member bodies. In the unlikely event that a problem relating to it is found, please inform the Central Secretariat at the address given below.

© ISO 2003

All rights reserved. Unless otherwise specified, no part of this publication may be reproduced or utilized in any form or by any means, electronic or mechanical, including photocopying and microfilm, without permission in writing from either ISO at the address below or ISO's member body in the country of the requester.

ISO copyright office
Case postale 56 • CH-1211 Geneva 20
Tel. + 41 22 749 01 11
Fax + 41 22 749 09 47
E-mail copyright@iso.org
Web www.iso.org

Published in Switzerland

Foreword

ISO (the International Organization for Standardization) is a worldwide federation of national standards bodies (ISO member bodies). The work of preparing International Standards is normally carried out through ISO technical committees. Each member body interested in a subject for which a technical committee has been established has the right to be represented on that committee. International organizations, governmental and non-governmental, in liaison with ISO, also take part in the work. ISO collaborates closely with the International Electrotechnical Commission (IEC) on all matters of electrotechnical standardization.

International Standards are drafted in accordance with the rules given in the ISO/IEC Directives, Part 2.

The main task of technical committees is to prepare International Standards. Draft International Standards adopted by the technical committees are circulated to the member bodies for voting. Publication as an International Standard requires approval by at least 75 % of the member bodies casting a vote.

Attention is drawn to the possibility that some of the elements of this document may be the subject of patent rights. ISO shall not be held responsible for identifying any or all such patent rights.

ISO 4404-2 was prepared by Technical Committee ISO/TC 28, *Petroleum products and lubricants*.

ISO 4404 consists of the following parts, under the general title *Petroleum and related products — Determination of the corrosion resistance of fire-resistant hydraulic fluids*:

- *Part 1: Water-containing fluids*
- *Part 2: Non-aqueous fluids*

Petroleum and related products — Determination of the corrosion resistance of fire-resistant hydraulic fluids —

Part 2: Non-aqueous fluids

WARNING — The use of this International Standard may involve hazardous materials, operations and equipment. This International Standard does not purport to address all of the safety problems associated with its use. It is the responsibility of the user of this International Standard to establish appropriate safety and health practices and determine the applicability of regulatory limitations prior to use.

1 Scope

This part of ISO 4404 specifies a procedure for the determination of the corrosion-inhibiting properties of non-aqueous hydraulic fluids within the category HFD, as classified in ISO 6743-4.

It provides a qualitative assessment of corrosion of five of the most common metals used in the construction of hydraulic systems, but other metals and/or alloys could be added or substituted for these metals for particular installations.

NOTE The determination of corrosion resistance of aqueous hydraulic fluids within categories HFA, HFB and HFC is described in ISO 4404-1.

2 Normative references

The following referenced documents are indispensable for the application of this document. For dated references, only the edition cited applies. For undated references, the latest edition of the referenced document (including any amendments) applies.

ISO 3170:—¹⁾, *Petroleum liquids — Manual sampling*

ISO 3819:1985, *Laboratory glassware — Beakers*

ISO 5272:1979, *Toluene for industrial use — Specifications*

ISO 6743-4:1999, *Lubricants, industrial oils and related products (class L) — Classification — Part 4: Family H (Hydraulic systems)*

1) To be published. (Revision of ISO 3170:1988)

3 Principle

Test pieces of selected metals are polished, weighed and immersed, separately and in pairs, in the test fluid for 672 h at 35 °C. At the end of the test period, the change in mass of the test piece is recorded and the appearance of both the test pieces and test fluid is assessed against arbitrary classification scales.

4 Reagents and materials

4.1 **Heptane**, commercial grade.

4.2 **Toluene**, conforming to the requirements of grade 2 of ISO 5272.

4.3 **Abrasive cloth or paper**, made of silicon carbide, of nominal grit sizes 125 µm, 65 µm, 37 µm and 26 µm.

NOTE Papers and cloths are often sold against arbitrary grit sizes. The above represent P 120, P 240, P 400 and P 600 respectively.

4.4 **Absorbent cotton (cotton wool)**

5 Apparatus

5.1 **Beakers**, of capacity 400 ml made of borosilicate glass, generally conforming to the requirements of ISO 3819, approximately 135 mm in height, without spouts.

5.2 **Watch-glasses**, of diameter 90 mm to 110 mm, with a hole of approximately 8 mm diameter drilled centrally (see second paragraph of 5.3).

5.3 **Glass hooks**, shaped to allow free suspension of the test pieces in the beaker, either directly, or by means of the spacer (5.4), and having a spherical suspension end of diameter 12 mm to 15 mm.

The combination of the hole in the watch-glass and/or shim, and the spherical end of the glass hook, should provide an effective closure.

5.4 **Spacers and bolts**, made of nylon, spacers 15 mm × 10 mm × 1 mm with two holes of 5 mm in diameter and 8 mm apart, each spacer fitted with a nylon bolt of 4 mm in diameter. Nylon spacer(s) [shim(s)], with a centrally drilled 8 mm diameter hole, may be needed to adjust the height of the test specimens in the beaker (see 2 in Figure 1).

5.5 **Heating bath**, consisting a thermostatically controlled bath or oven of sufficient capacity to accommodate at least ten beakers, and capable of maintaining a temperature of 35 °C ± 1 °C throughout the test period. The bath shall be equipped with a stirrer, or the oven with a fan, to ensure even temperature distribution in all areas. At least four temperature sensors will be required.

5.6 **Analytical balance**, capable of weighing to the nearest 0,2 mg.

5.7 **Forceps**, spade-ended or round-ended, either corrosion-resistant metal or plastic, with plain inner faces.

6 Test pieces

Rectangles of the selected metals, 100 mm in length, 20 mm in width and 1 mm to 2 mm in thickness, with a hole 4 mm to 5 mm in diameter located centrally at one end approximately 5 mm from the edge. The composition of the five standard metals is given in Table 1.

Dimensions in millimetres

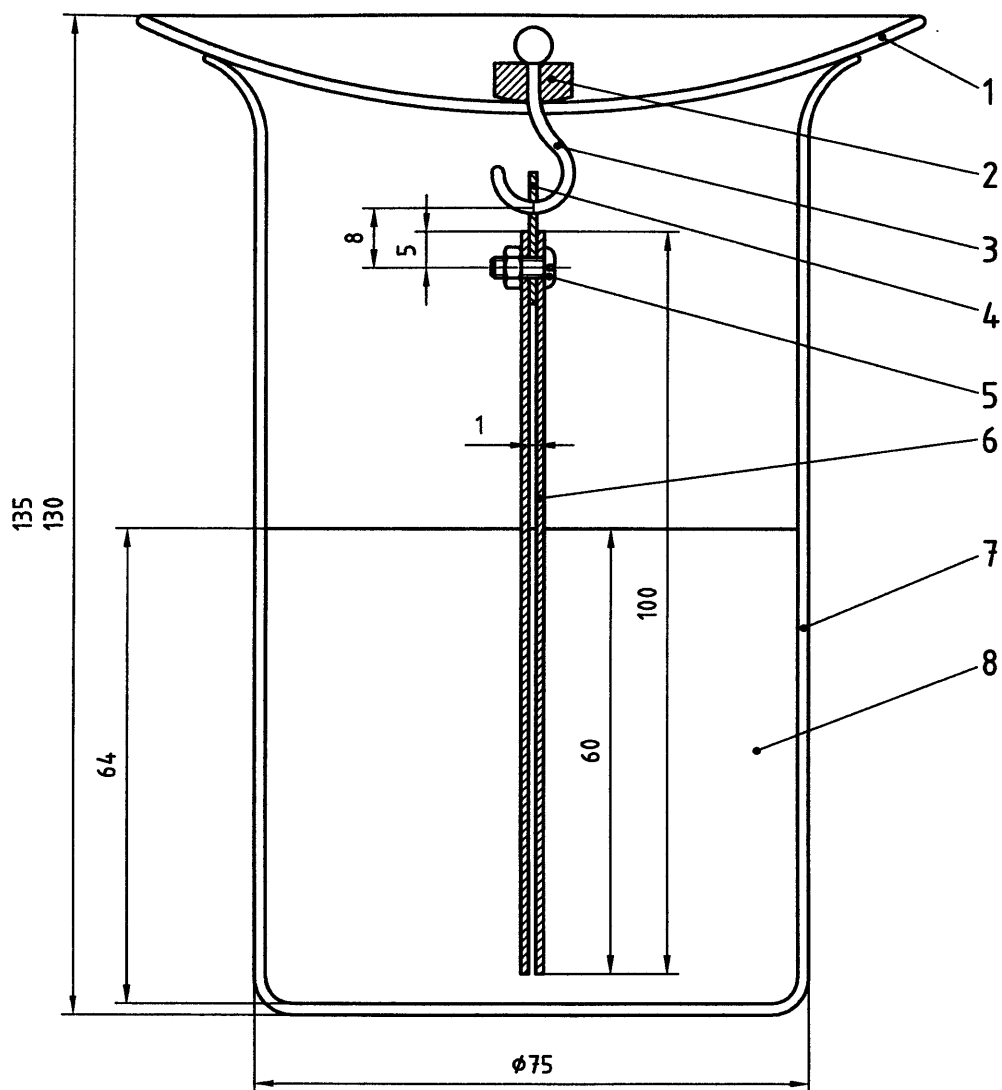
**Key**

- 1 watch-glass
- 2 shim
- 3 glass hook
- 4 nylon spacer (15 × 10 × 1)
- 5 nylon bolt and nut, diameter 4
- 6 pair of test strips
- 7 beaker without a spout
- 8 test fluid

Figure 1 — Illustrative arrangement of test pieces in the beaker

7 Samples and sampling

7.1 Unless otherwise specified, samples shall be obtained by the procedures described in ISO 3170.

7.2 A minimum laboratory sample size of 3 litres is required for this test, and this shall be prepared in a single container at the sampling site.

8 Preparation of test pieces

8.1 Select thirteen test pieces (Clause 6): four of zinc, three each of steel and aluminium, two of copper and one of brass, and polish the edges with a coarse abrasive cloth or paper (4.3) to remove any burr and finish with 26 μm cloth or paper. Ensure that the cloth or paper used for one metal does not come into contact with any other metal.

8.2 Polish the surfaces of each test piece with abrasive cloth or paper in order of fineness, finishing with 26 μm cloth or paper. From this point, handle the test pieces only with the forceps (5.7).

The selection of the coarser grades of cloth or paper will depend on the original surface condition of the test piece being polished, but it is recommended that at least two coarser grades are used before the final polishing.

8.3 Rub the surfaces of the polished test piece with absorbent cotton (4.4) followed by absorbent cotton soaked in heptane (4.1). Rinse the test piece in heptane and dry in a current of warm dry air.

Prepared test pieces should have a maximum time between preparation and the test procedure. They may be kept after preparation, for up to 30 min immersed in heptane, but care should be taken to ensure that no contact occurs between test pieces of different metals.

Table 1 — Composition of metal test pieces

Metal	Composition	
	%(m/m)	
Steel	C	0,35 to 0,45
	Mn	0,50 to 0,80
	Si max.	0,10
	S max.	0,035
	P max.	0,035
Copper	Cu min.	99,9
	(Electrolytic grade)	
Brass	Cu	65 \pm 0,5
	Zn	35 \pm 0,5
Zinc	Zn min.	99,5
Aluminium	Al min.	99,5
NOTE For the purposes of this part of ISO 4404, the term "%(m/m)" represents the mass fraction of a material.		

9 Procedure

9.1 Weigh each dry test piece to the nearest 0,2 mg.

9.2 Pour 250 ml \pm 10 ml of test fluid into each of ten beakers.

9.3 In five beakers, place one test piece of each metal on the hook (5.3) suspended from the watch-glass (5.2) such that 60 mm \pm 3 mm of the test piece is immersed in the test fluid, and the test piece is a minimum of 3 mm from the bottom of the beaker. Figure 1 gives an illustrative layout of test pieces in the beaker.

9.4 Prepare four pairs of metal test pieces by means of the nylon spacers and bolts (5.4), with the second hole in the spacer used for suspension. Check that the distance between the two test pieces is uniform and not less than 1 mm. The four pairs are

- steel and zinc,
- copper and zinc,
- aluminium and zinc, and
- steel and aluminium.

9.5 Suspend the pairs of test pieces in the test fluid with the same immersion conditions as the single test pieces.

Because of the lower suspension of the test pieces on the hook, it will generally be required to use a spacer between the spherical end of the hook and the hole in the watch-glass (5.2). The spacer chosen should maintain the effective closure.

9.6 Place the ten beakers, nine containing test pieces and one of test fluid only, in the heating bath or oven (5.5) and check that the temperature of the chamber is evenly distributed at 35 °C \pm 1 °C, within 30 min. Maintain the test conditions for 672 h \pm 2 h.

9.7 At the end of the test period, remove the test pieces from the test fluid, disassemble the pairs, and lay them all out on a white absorbent paper. Examine each test piece in the two zones (liquid exposure and vapour exposure) and record the corrosion according to the classification given in Table 2.

9.8 Examine each beaker of test fluid and record the condition according to the classification given in Table 3.

9.9 Rinse each test piece, held by the forceps in the vicinity of the suspension hole, in toluene (4.2), taking care not to disturb any deposits on the surface. Dry in a stream of warm dry air and reweigh to the nearest 0,2 mg.

Table 2 — Test-piece corrosion classification

Classification	Description
0	No change
1	Slight colour change or oxidation of less than 20 % of surface
2	Strong colour change
3	Deposits or oxidation of more than 20 % of surface
4	Corrosion or pitting
5	Other effects (to be specified)

Table 3 — Test-fluid condition classification

Classification	Description
0	No change
1	Deposits
(2)	Separation (not applicable to HFD fluids)
3	Cloudiness
4	Colour change
5	Other effects (to be specified)

10 Expression of results

10.1 Report all results obtained for the test pieces and fluids. For each result concerning a metal test piece, identify whether the test was carried out on a single metal test piece or a paired test piece. For paired test pieces, identify the other metal. For results concerning the fluids, report the metal or metal pair immersed or whether there was no metal immersed (blank test).

10.2 Report the change in mass of each test piece to the nearest 0,5 mg.

10.3 Report the corrosion classification of each test piece, in each of the two zones.

10.4 Report the test fluid condition classification.

11 Test report

The test report shall contain at least the following information:

- a) a reference to this part of ISO 4404;
- b) the type and complete identification of the product tested;
- c) the test result (see Clause 9);
- d) any deviation, by agreement or otherwise, from the procedure specified;
- e) the date of the test.

ISO 4404-2:2003(E)

ICS 75.120

Price based on 6 pages

© ISO 2003 — All rights reserved