**Petroleum and related products —
Determination of the corrosion resistance
of fire-resistant hydraulic fluids —**

**Part 1:
Water-containing fluids**

*Pétrole et produits connexes — Détermination de la résistance
à la corrosion de fluides hydrauliques difficilement inflammables —*

Partie 1: Fluides contenant de l'eau



Reference number
ISO 4404-1:2012(E)

© ISO 2012



COPYRIGHT PROTECTED DOCUMENT

© ISO 2012

All rights reserved. Unless otherwise specified, no part of this publication may be reproduced or utilized in any form or by any means, electronic or mechanical, including photocopying and microfilm, without permission in writing from either ISO at the address below or ISO's member body in the country of the requester.

ISO copyright office
Case postale 56 • CH-1211 Geneva 20
Tel. + 41 22 749 01 11
Fax + 41 22 749 09 47
E-mail copyright@iso.org
Web www.iso.org

Published in Switzerland

Contents

Page

Foreword	iv
Introduction	v
1 Scope	1
2 Normative references	1
3 Terms and definitions	1
4 Principle	2
5 Reagents and materials	2
6 Apparatus	2
7 Producing the test fluid from an HFA-type fluid concentrate	6
8 Procedure	6
8.1 Test preparation	6
8.2 Test	7
8.3 Assessment	7
9 Expression of results	9
10 Precision	9
11 Test report	9
Annex A (normative) Preparation of test waters	10
Annex B (informative) Specifications of alternative standard materials for test strips	12
Annex C (informative) Explanatory comments	13
Annex D (informative) Table for reporting of results	14
Bibliography	15

Foreword

ISO (the International Organization for Standardization) is a worldwide federation of national standards bodies (ISO member bodies). The work of preparing International Standards is normally carried out through ISO technical committees. Each member body interested in a subject for which a technical committee has been established has the right to be represented on that committee. International organizations, governmental and non-governmental, in liaison with ISO, also take part in the work. ISO collaborates closely with the International Electrotechnical Commission (IEC) on all matters of electrotechnical standardization.

International Standards are drafted in accordance with the rules given in the ISO/IEC Directives, Part 2.

The main task of technical committees is to prepare International Standards. Draft International Standards adopted by the technical committees are circulated to the member bodies for voting. Publication as an International Standard requires approval by at least 75 % of the member bodies casting a vote.

Attention is drawn to the possibility that some of the elements of this document may be the subject of patent rights. ISO shall not be held responsible for identifying any or all such patent rights.

ISO 4404-1 was prepared by Technical Committee ISO/TC 28, *Petroleum products and lubricants*.

This second edition cancels and replaces the first edition (ISO 4404-1:2001), which has been technically revised.

ISO 4404 consists of the following parts, under the general title *Petroleum and related products — Determination of the corrosion resistance of fire-resistant hydraulic fluids*:

- *Part 1: Water-containing fluids*
- *Part 2: Non-aqueous fluids*

Introduction

Water-containing hydraulic fluids are used in systems where fire resistance is required due to operating conditions. The corrosion resistance of such fluids has to be assessed in order to choose a suitable system design and prepare maintenance instructions.

Petroleum and related products — Determination of the corrosion resistance of fire-resistant hydraulic fluids —

Part 1: Water-containing fluids

WARNING — The use of this part of ISO 4404 may involve hazardous materials, operations and equipment. This part of ISO 4404 does not purport to address all of the safety problems associated with its use. It is the responsibility of the user of this part of ISO 4404 to establish appropriate safety and health practices and determine the applicability of regulatory limitations prior to use.

1 Scope

This part of ISO 4404 specifies a test method to determine the influence on metals of fire-resistant fluids in categories HFA, HFB and HFC, as classified in ISO 6743-4. It evaluates the corrosion protection provided by these fluids towards metal components used in hydraulic systems and installations.

A similar technique for fluids in category HFD is described in ISO 4404-2.

2 Normative references

The following referenced documents are indispensable for the application of this document. For dated references, only the edition cited applies. For undated references, the latest edition of the referenced document (including any amendments) applies.

ISO 648: 2008, *Laboratory glassware — Single-volume pipettes*

ISO 3696: 1987, *Water for analytical laboratory use — Specification and test methods*

ISO 3819: 1985, *Laboratory glassware — Beakers*

ISO 5598: 2008, *Fluid power systems and components — Vocabulary*

ISO 6344-1: 1998, *Coated abrasives — Grain size analysis — Part 1: Grain size distribution test*

ISO 20783-1: 2011, *Petroleum and related products — Determination of emulsion stability of fire-resistant fluids — Part 1: Fluids in category HFAE*

DIN 12331: 1988, *Laboratory glassware; beakers*

3 Terms and definitions

For the purposes of this document, the terms and definitions given in ISO 5598:2008 apply.

4 Principle

Test strips of appropriate metals, both singly and in pairs, are partially submerged in the test fluid at a specific temperature and for a specific period. The change in mass of each test strip, its surface appearance and the change in the appearance of the fluid during the test are determined.

NOTE 1 When assessing the corrosivity of HFAE and HFAS fluids, it may be necessary to dilute an additive concentrate with water and the quality of the water can significantly affect the test results. The diluent, therefore, needs to be chosen carefully and, preferably, to be representative of commercial use. The selection could be one of the test waters listed in Annex A, deionized water or mains water as agreed between the user and the fluid supplier.

NOTE 2 The selection of the metals for corrosion testing may depend on the application and on the type of fluid being tested. For example, aluminium may not be used in mining applications while contact between HFC fluids and zinc shall be minimized as far as possible.

5 Reagents and materials

5.1 **Acetone**, analytical grade.

5.2 **Heptane**, analytical grade.

5.3 **Water**, selected from one of the following:

- a) a test water of composition specified in Annex A,
- b) deionized water conforming to grade 3 of ISO 3696:1987, or
- c) the supply water to be used commercially.

5.4 **Metal salts** (listed in Table A.1), analytical grade.

6 Apparatus

6.1 **Glass beakers**, of capacity 400 ml, height approximately 135 mm, without a spout, conforming to ISO 3819:1985 (see Figure 1). A maximum of ten is required for each test fluid.

6.2 **Glass beaker**, type H 1000, conforming to DIN 12331:1988 (of capacity 1 000 ml).

6.3 **Pipette**, complying with ISO 648:2008, class A.

6.4 **Watch glasses** (ten required), for covering the beakers (6.1), with a hole in the centre for suspending glass hooks (6.5) (see Figures 1 and 2).

6.5 **Glass hooks**, allowing free suspension of the test strips in the beaker and formed in such a way that the hole in the watch glass will be closed by the suspension device (see Figures 1 and 2).

6.6 **Heating bath or oven**, thermostatically controlled and capable of maintaining the test fluids at $35\text{ °C} \pm 1\text{ °C}$. If a heating bath is used, it shall be equipped to allow adequate stirring to ensure even temperature distribution.

6.7 **Shims**, of rubber, cork or plastic, 8 mm thick and 1,5 cm to 2 cm in diameter.

6.8 **Analytical balance**, accurate to 0,000 2 g.

6.9 **Abrasive paper**, of different aluminium oxide grit sizes, including P 120, P 400 and P 600 types according to ISO 6344-1:1998.

6.10 Cotton wool.

6.11 Plastic tweezers, suitable for handling the test strips.

6.12 Desiccator, containing dry silica gel desiccant. Alternatively, a vacuum desiccator may be used.

6.13 Abrasive wheel (fine), rotating at approximately 1 400 r/min.

6.14 Test strips, of the materials listed in Table 1, measuring 100 mm × 20 mm × 1 mm and having a hole of 4 mm in diameter at one end for suspending on the glass hook (6.5).

The steel test strips shall be non-heat-treated.

Test strips measuring 100 mm × 20 mm × 2 mm may also be used.

NOTE 1 This test can be performed with any other material (metal and/or alloy) used in hydraulic systems, provided that the dimensions of the test strips are observed as specified in this subclause.

NOTE 2 Zinc reacts chemically with some water-based fluids, particularly water polymer (water glycol) solutions. For this reason, the use of zinc in systems containing HFC fluids is currently limited to small fixtures and fittings.

6.15 Spacer, of nylon, rectangular, 15 mm × 10 mm × 1 mm, with two holes of 5 mm in diameter, for the glass hook (6.5) and bolt (6.16) (see Figure 2).

6.16 Fixing.

NOTE M4 × 16 machine screw, Nylon 6.6, and plain nut, Nylon 6.6.

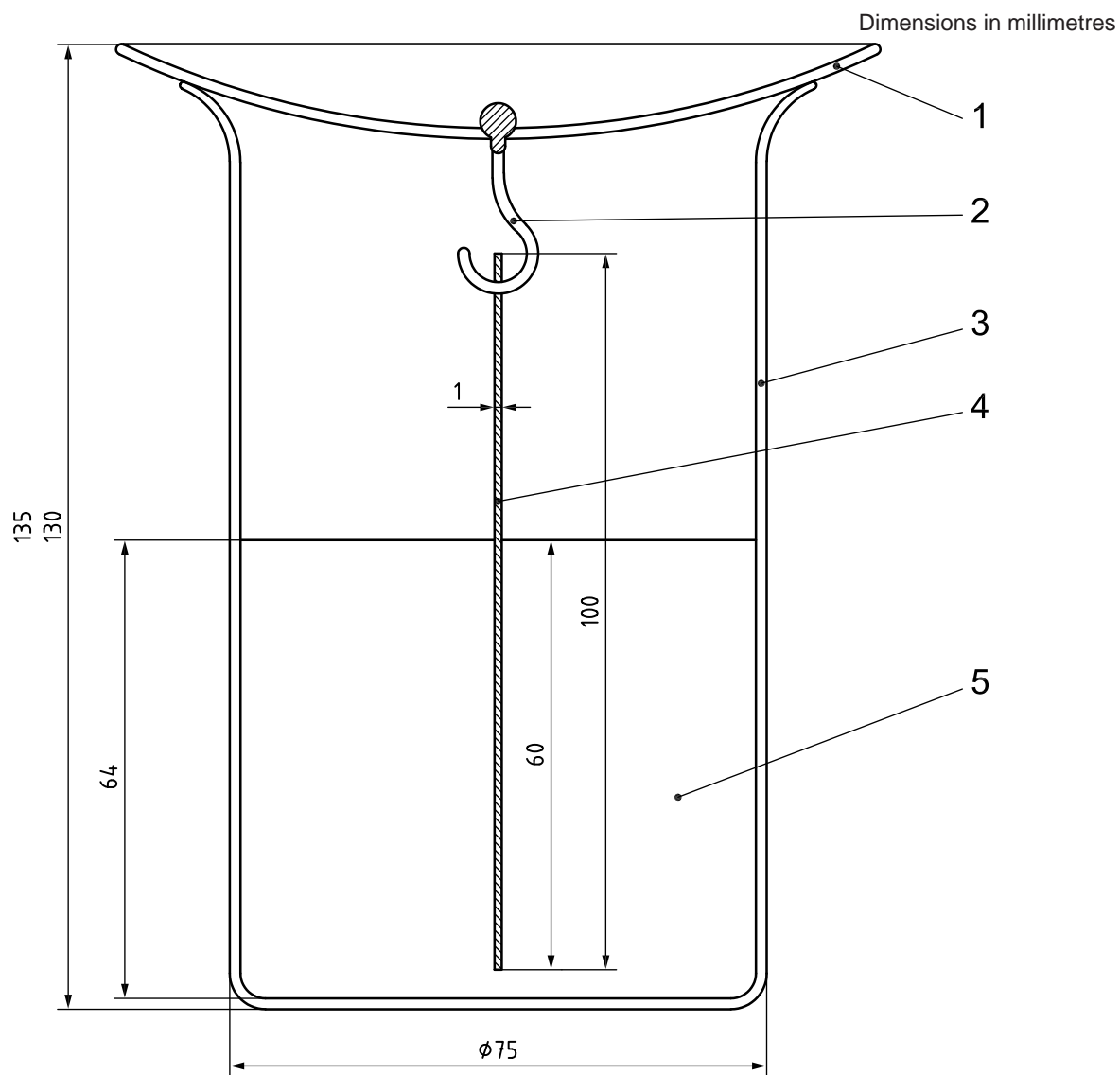

Key

- 1 watch glass
- 2 glass hook
- 3 beaker without a spout
- 4 test strip
- 5 test fluid

Figure 1 — Assembly for a single test strip

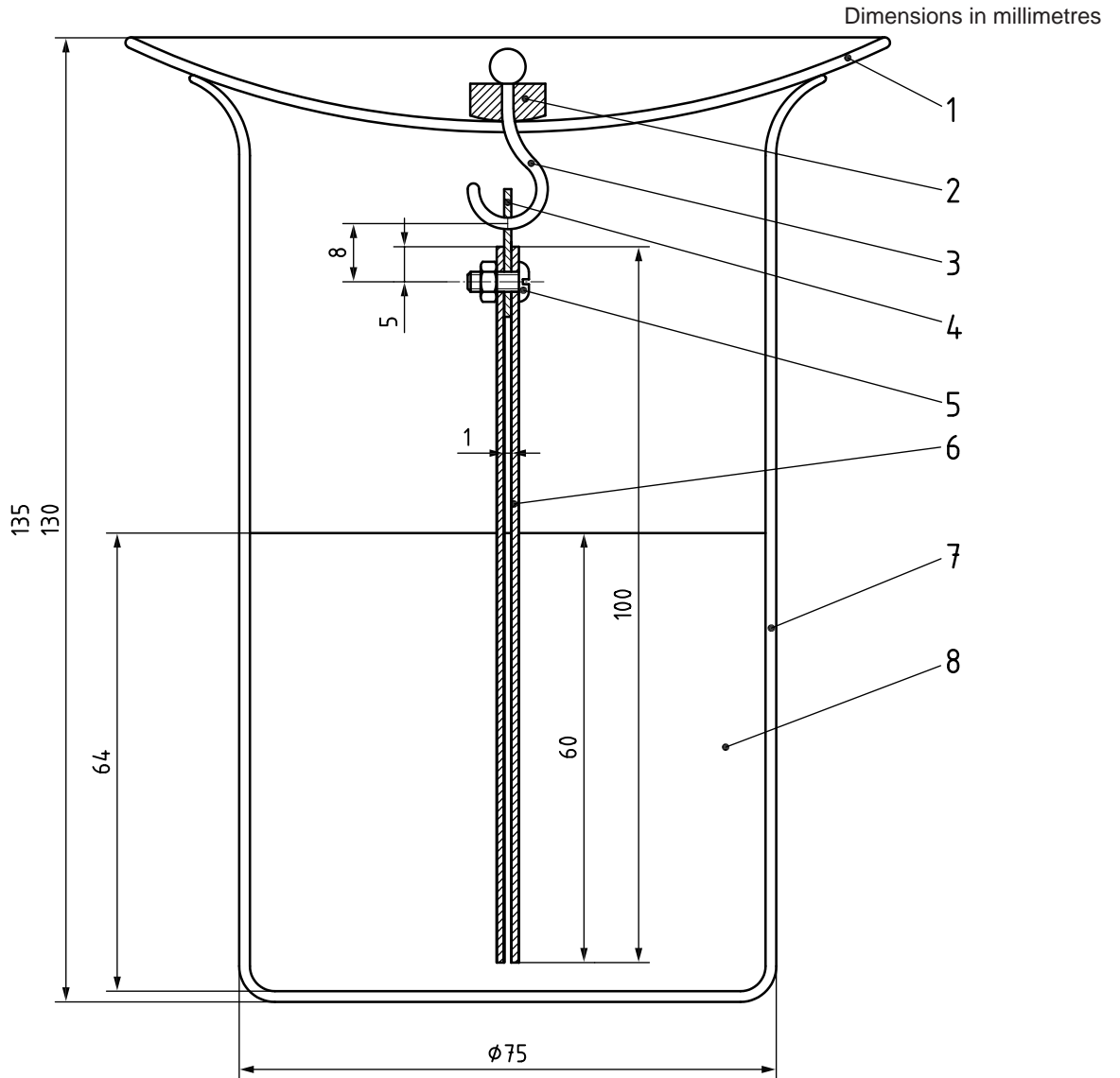

Key

- | | |
|------------------------------|----------------------------------|
| 1 watch glass | 5 nylon bolt and nut, diameter 4 |
| 2 shim | 6 pair of test strips |
| 3 glass hook | 7 beaker without a spout |
| 4 nylon spacer (15 × 10 × 1) | 8 test fluid |

Figure 2 — Assembly for a pair of test strips

Table 1 — Specifications of standard test materials for test strips

Metal	Composition % (m/m)		References		
			ISO (grade)	EN (grade)	ASTM (grade)
Steel	Fe	97,31 to 97,69	—	EN 10083-2:2006 Grade C45 +A (with some annealing but no surface treatment)	
	C	0,42 to 0,50			
	Mn	0,5 to 0,8			
	Si max.	0,40			
	S max.	0,045			
	P max.	0,045			
	Cr max.	0,40			
	Mo max.	0,10			
Ni max.	0,40				
Copper	Cu	99,9		EN 1652:1997	ASTM B152/ B152M-09 (C 11000)
	(electrolytic copper)				
Brass	Cu	65			ASTM B36/ B36M-08a (C 26800)
	Zn	35			
Zinc	Zn	99,5	ISO 752 (99,5)	EN 1179:2003 (Z4)	—
	(pure zinc)				
Aluminium	Al	99,5	ISO 209 (Al 99,5/1050A)	—	—
	(pure aluminium)				
NOTE For standards that are equivalent to those referenced in this table, see Annex B.					

7 Producing the test fluid from an HFA-type fluid concentrate

Prepare a quantity of the emulsion (HFAE/HFB fluid types) or solution (HFAS type) in a glass beaker (6.2) by adding the required amount of concentrate to the selected water using the pipette (6.3). Stir constantly and complete the addition within a period of 10 min. After all the concentrate has been added, stirring shall continue for a further 5 min, and then 250 ml of the test fluid shall be measured immediately into the prepared beakers (see 8.1.6).

If a test water is chosen from Annex A, it shall be of the highest hardness still able to form a stable emulsion, i.e. an emulsion which satisfies ratings 1A and 1R of ISO 20783-1:2011. Preferably, the water selected should be as close as possible in composition to that anticipated in commercial use.

Start the test on the same day the emulsion or solution has been prepared.

8 Procedure

8.1 Test preparation

8.1.1 Before polishing the test strips, carefully remove any burrs from the edges of the strips (6.14) using the grinding wheel (6.13).

8.1.2 Polish the test strips with abrasive aluminium oxide paper (6.9), e.g. in the order of P 120, P 400 and finally P 600, until a smooth surface is achieved, free from scratches and machining marks.

8.1.3 Subsequently, handle test strips exclusively with plastic tweezers (6.11). Rub the test strips with dry cotton wool (6.10) and then with cotton wool soaked in heptane (5.2).

8.1.4 Allow the solvent to evaporate, then quickly transfer the specimens to a desiccator (6.12) for 24 h to 36 h.

8.1.5 Immediately before use, weigh the test strips and record their mass to the nearest 1 mg.

8.1.6 Fill each of the beakers (6.1) with 250 ml of the homogenized test fluid.

8.1.7 When testing individual metals, suspend single test strips of steel, copper, zinc, aluminium and brass on glass hooks (6.5) below the watch-glass covers so that $60 \text{ mm} \pm 2 \text{ mm}$ of their entire length is immersed in the test fluid (see Figure 1).

NOTE These single test strips can also be suspended with the spacer (6.15) and the bolt (6.16).

8.1.8 When testing metal pairs, suspend the following combinations of test strips in the test fluid as described in 8.1.7 above:

- a) steel and zinc;
- b) copper and zinc;
- c) zinc and aluminium;
- d) aluminium and steel.

8.1.9 Using shims (6.7), suspend these pairs of test strips on glass hooks (6.5) below the watch-glass covers so that $60 \text{ mm} \pm 2 \text{ mm}$ of their length is immersed in the test fluid and so that, by means of the spacer (6.15), the distance between the strip surfaces is 1 mm.

8.1.10 Keep one beaker (6.1), containing the test fluid and covered by the watch glass, free of test strips to evaluate the changes in the fluid during the test.

8.2 Test

8.2.1 Place all ten beakers in the heating bath or oven (6.6). Maintain the temperature of the test fluid at $35 \text{ }^\circ\text{C} \pm 1 \text{ }^\circ\text{C}$.

8.2.2 Leave all the beakers undisturbed in the heating bath or oven for a period of $672 \text{ h} \pm 2 \text{ h}$ (equivalent to 28 days).

8.3 Assessment

8.3.1 After completion of the test, visually inspect the test strips and the test fluid under normal light (approximately 646 lux) and assess the following:

- a) test strips:
 - general appearance;
 - deposits formed;

b) test fluid:

- colour;
- appearance;
- deposits.

Handle the test strips only with the tweezers (6.11).

Rate the appearance of metal strips according to Table 2.

Table 2 — Rating system for metal strips

Rating	Description
0	no effect
1	slight colour change or oxidation of less than 20 % of the surface
2	strong colour change
3	deposits or oxidation on more than 20 % of the surface
4	corrosion or pitting
5	other effects to be specified

Rate the effects on the fluids according to Table 3.

Table 3 — Rating system for fluids

Rating	Description
0	no effect
1	deposits
2	separation, e.g. surface accumulation of oil, or distinct phase separation
3	cloudiness of an initially clear fluid
4	colour change
5	other effects to be specified

NOTE The ratings in Table 3 are not progressive and a fluid may be rated for more than one effect.

8.3.2 After the visual assessments, clean the test strips by immersing them separately in beakers containing water and/or solvent, and moving the strips in the solvent until all the test fluid is removed.

Use the following fluid/solvent combination:

- a) test fluids HFAE and HFAS: first distilled water (5.3), then heptane (5.2), then acetone (5.1);
- b) test fluid HFB: first heptane (5.2), then acetone (5.1);
- c) test fluid HFC: first distilled water (5.3), then acetone (5.1).

If, after the immersion, test fluid is still visible on the surface of the test strip, repeat this procedure.

After immersion in acetone, dry the test strips in air, still handling them with tweezers, until all traces of acetone have evaporated.

After the test strips have been cleaned and dried, immediately weigh each one and record their mass to the nearest 1 mg.

9 Expression of results

9.1 Report the results of the visual inspection (see 8.3.1).

9.2 Report the difference in mass of each test strip used, indicating increases during the test by “+” and decreases during the test by “-” between the masses recorded in 8.1.5 and 8.3.2. A suitable table for recording the data is given in Annex D.

NOTE For interpretation of the results, see the explanatory comments in Annex C.

10 Precision

The precision of this method has not been established.

11 Test report

The test report shall contain at least the following information:

- a) a reference to this part of ISO 4404, i.e. ISO 4404-1:2012;
- b) the type and complete identification of the product tested;
- c) the test results (see Clause 9);
- d) the type of test water used (see Clause 7);
- e) any deviation, by agreement or otherwise, from the procedure specified;
- f) the date of the test.

A possible format for reporting the results is given in Annex D.

.....

Annex A (normative)

Preparation of test waters

A.1 Prepare at least 2,5 l of test water for each test using suitable amounts of salts as given in Table A.1.

Table A.1 — Composition of test waters

Salts to be added	Concentration mg/l	Ion concentration mg/l		Hardness
Test water N° 1				
Sodium hydrogen carbonate NaHCO ₃	90	24,6 Na ⁺	65,4 HCO ₃ ⁻	= 87 mg/kg temporary hardness as Ca(HCO ₃) ₂
Magnesium chloride hexahydrate MgCl ₂ ·6H ₂ O	145	17,3 Mg ²⁺	50,6 Cl ⁻	= 71,3 mg/kg permanent hardness as CaCO ₃
Calcium sulfate dihydrate CaSO ₄ ·2H ₂ O	220	51,3 Ca ²⁺	122,8 SO ₄ ²⁻	= 128,1 mg/kg permanent hardness as CaCO ₃
Sodium sulfate Na ₂ SO ₄	40	13,0 Na ⁺	27,0 SO ₄ ²⁻	
Sodium chloride NaCl	245	96,3 Na ⁺	148,7 Cl ⁻	
Sodium nitrate NaNO ₃	27	7,3 Na ⁺	19,7 NO ₃ ⁻	
Test water N° 2				
Sodium hydrogen carbonate NaHCO ₃	255	69,8 Na ⁺	185,5 HCO ₃ ⁻	= 245,9 mg/kg temporary hardness as Ca(HCO ₃) ₂
Magnesium chloride hexahydrate MgCl ₂ ·6H ₂ O	420	50,2 Mg ²⁺	146,6 Cl ⁻	= 206,8 mg/kg permanent hardness as CaCO ₃
Calcium sulfate dihydrate CaSO ₄ ·2H ₂ O	260	60,6 Ca ²⁺	145,1 SO ₄ ²⁻	= 151,3 mg/kg permanent hardness as CaCO ₃
Sodium chloride NaCl	90	35,4 Na ⁺	54,6 Cl ⁻	
Sodium nitrate NaNO ₃	27	7,3 Na ⁺	19,7 NO ₃ ⁻	
Test water N° 3				
Magnesium sulfate heptahydrate MgSO ₄ ·7H ₂ O	924	91,2 Mg ²⁺	360,1 SO ₄ ²⁻	= 375,5 mg/kg permanent hardness as CaCO ₃
Calcium sulfate dihydrate CaSO ₄ ·2H ₂ O	645	150,4 Ca ²⁺	360,0 SO ₄ ²⁻	= 375,4 mg/kg permanent hardness as CaCO ₃
Sodium chloride NaCl	330	130,0 Na ⁺	200,0 Cl ⁻	
Test water N° 4				
Magnesium sulfate heptahydrate MgSO ₄ ·7H ₂ O	308	30,4 Mg ²⁺	120,0 SO ₄ ²⁻	= 125,2 mg/kg permanent hardness as CaCO ₃
Calcium sulfate dihydrate CaSO ₄ ·2H ₂ O	215	50,1 Ca ²⁺	120,0 SO ₄ ²⁻	= 125,1 mg/kg permanent hardness as CaCO ₃
Sodium chloride NaCl	330	130,0 Na ⁺	200,0 Cl ⁻	

A.2 First, dissolve the calcium sulfate in the distilled or deionized water (5.3) using an appropriate calibrated flask.

NOTE Calcium sulfate is hard to dissolve and can require two days of stirring. It is generally delivered as a fine powder. If not, it can be helpful to grind it.

A.3 After the dissolution of the calcium sulfate has been completed, the other metal salts shall be dissolved in turn.

A.4 During the agitation, the flask shall be kept stoppered.

NOTE The shelf-life of the test water is 24 h maximum.

Table A.2 — Characteristics of test waters

Test water characteristics	Units	Test waters				Comments
		N° 1	N° 2	N° 3	N° 4	
Total hardness (Ca ²⁺ + Mg ²⁺)	mg/kg mg/kg	199,4 111,8	358,1 200	750,9 421	250,3 140	CaCO ₃ equivalent CaO equivalent
Temporary hardness (alkalinity) (HCO ₃ ⁻ acid capacity)	mg/kg	87	245,9	—	—	Ca(HCO ₃) ₂ equivalent
Mg ²⁺ ions	mg/kg	17	50	91	30	
Ca ²⁺ ions	mg/kg	51	61	150	50	
SO ₄ ²⁻ ions	mg/kg	150	145	720	240	
NO ₃ ⁻ ions	mg/kg	20	20	—	—	
Cl ⁻ ions	mg/kg	199	201	200	200	
Na ⁺ ions	mg/kg	141	113	130	130	
Alkaline earth	mmol/l	1,99	3,58	7,5	2,50	Ca ²⁺ + Mg ²⁺

Annex B (informative)

Specifications of alternative standard materials for test strips

Table B.1 — Specifications of alternative standard test materials for test strips

Metal	Composition % (m/m)		References	
			ASTM (grade)	SAE (grade)
Steel	Fe	98,16 to 98,73	ASTM A29/ A29M-11a (ASTM 1045)	SAE J403 (ASTM 1045 or AISI 1045)
	C	0,43 to 0,50		
	Mn	0,6 to 0,9		
	Si max.	0,15 to 0,35		
	S max.	0,050		
	P max.	0,040		
Copper	Cu	99,9	—	SAE J463 (CA 110)
	(electrolytic copper)			
Brass	Cu	65	—	SAE J463 (CA 268)
	Zn	35		
Zinc	Zn	99,5	—	—
	(pure zinc)			
Aluminium	Al	99,5	—	—
	(pure aluminium)			

Annex C (informative)

Explanatory comments

When evaluating the results of a test in accordance with the method in this part of ISO 4404, the following information may be helpful.

- a) The mass loss should not exceed 11 mg per test strip for materials with a density of more than 7 kg/dm³ and 5 mg per test strip for materials with a density of less than 7 kg/dm³. The mass loss for zinc should not be more than 22 mg per test strip and, for aluminium, not more than 5 mg per test strip.
- b) Normally, no deposits should form on the test strip; the mass increase should not be more than 5 mg per test strip.
- c) No significant colour changes should occur on the metal surface immersed in the test fluid; if changes occur, an investigation should be conducted to determine the cause.
- d) No significant corrosion should be visible on the part of the strip not immersed in the fluid.

Annex D (informative)

Table for reporting of results

Name of product:		Date of test:		
Type of water used:		Dilution:		
Appearance of test solution/rating:				
a) before testing:		b) after testing:		
Metal coupons	Mass before test (mg)	Mass after test (mg)	Difference (mg)	Visual rating of coupon after test
Single specimens				
Steel				
Copper				
Zinc				
Aluminium				
Brass				
Metal pairs				
Steel/zinc	Fe			
	Zn			
Copper/zinc	Cu			
	Zn			
Zinc/aluminium	Zn			
	Al			
Steel/aluminium	Fe			
	Al			

Bibliography

- [1] ISO 209, *Aluminium and aluminium alloys — Chemical composition*
- [2] ISO 752, *Zinc ingots*
- [3] ISO 4404-2, *Petroleum and related products — Determination of the corrosion resistance of fire-resistant hydraulic fluids — Part 2: Non-aqueous fluids*
- [4] ISO 6743-4, *Lubricants, industrial oils and related products (class L) — Classification — Part 4: Family H (Hydraulic systems)*
- [5] ASTM A29/A29M-11a, *Standard specification for steel bars, carbon and alloy, hot-wrought, General requirements for*
- [6] ASTM B36/B36M-08a, *Standard specification for brass plate, sheet, strip, and rolled bar*
- [7] ASTM B152/B152M-09, *Standard specification for copper sheet, strip, plate, and rolled bar*
- [8] EN 1179, *Zinc and zinc alloys — Primary zinc*
- [9] EN 1652, *Copper and copper alloys — Plate, sheet, strip and circles for general purposes*
- [10] EN 10083-2, *Steels for quenching and tempering — Part 2: Technical delivery conditions for non-alloy steels*
- [11] SAE J403:2001, *Chemical compositions of SAE carbon steels*
- [12] SAE J463:2002, *Wrought copper and copper alloys*

ICS 75.120.00

Price based on 15 pages