**Fluid power systems and components —
Cylinder piston rod end types and
dimensions**

*Transmissions hydrauliques et pneumatiques — Dimensions et types
des extrémités des tiges de pistons pour vérins*



PDF disclaimer

This PDF file may contain embedded typefaces. In accordance with Adobe's licensing policy, this file may be printed or viewed but shall not be edited unless the typefaces which are embedded are licensed to and installed on the computer performing the editing. In downloading this file, parties accept therein the responsibility of not infringing Adobe's licensing policy. The ISO Central Secretariat accepts no liability in this area.

Adobe is a trademark of Adobe Systems Incorporated.

Details of the software products used to create this PDF file can be found in the General Info relative to the file; the PDF-creation parameters were optimized for printing. Every care has been taken to ensure that the file is suitable for use by ISO member bodies. In the unlikely event that a problem relating to it is found, please inform the Central Secretariat at the address given below.



COPYRIGHT PROTECTED DOCUMENT

© ISO 2009

All rights reserved. Unless otherwise specified, no part of this publication may be reproduced or utilized in any form or by any means, electronic or mechanical, including photocopying and microfilm, without permission in writing from either ISO at the address below or ISO's member body in the country of the requester.

ISO copyright office
Case postale 56 • CH-1211 Geneva 20
Tel. + 41 22 749 01 11
Fax + 41 22 749 09 47
E-mail copyright@iso.org
Web www.iso.org

Published in Switzerland

Contents

Page

Foreword	iv
Introduction.....	v
1 Scope	1
2 Normative references	1
3 Terms and definitions	1
4 Types and dimensions for hydraulic cylinder piston rod ends	2
5 Types and dimensions for pneumatic cylinder piston rod ends	7
6 Identification statement (reference to this International Standard)	8
Bibliography	9

Foreword

ISO (the International Organization for Standardization) is a worldwide federation of national standards bodies (ISO member bodies). The work of preparing International Standards is normally carried out through ISO technical committees. Each member body interested in a subject for which a technical committee has been established has the right to be represented on that committee. International organizations, governmental and non-governmental, in liaison with ISO, also take part in the work. ISO collaborates closely with the International Electrotechnical Commission (IEC) on all matters of electrotechnical standardization.

International Standards are drafted in accordance with the rules given in the ISO/IEC Directives, Part 2.

The main task of technical committees is to prepare International Standards. Draft International Standards adopted by the technical committees are circulated to the member bodies for voting. Publication as an International Standard requires approval by at least 75 % of the member bodies casting a vote.

Attention is drawn to the possibility that some of the elements of this document may be the subject of patent rights. ISO shall not be held responsible for identifying any or all such patent rights.

ISO 4395 was prepared by Technical Committee ISO/TC 131, *Fluid power systems*, Subcommittee SC 3, *Cylinders*.

This second edition cancels and replaces the first edition (ISO 4395:1978), which has been technically revised.

Introduction

In fluid power systems, power is transmitted and controlled through a liquid (for hydraulics) or a gas (for pneumatics) under pressure within an enclosed circuit.

One component of such systems is the cylinder. This is a device that converts power into linear mechanical force and motion. It consists of a moveable element, i.e. a piston and piston rod, operating within a cylindrical bore.

Fluid power systems and components — Cylinder piston rod end types and dimensions

1 Scope

This International Standard establishes a basic series for piston rod end types for application on cylinders used in hydraulic and pneumatic fluid power systems.

It specifies thread dimensions and configurations for use with hydraulic and pneumatic cylinder piston rod ends, as well as the dimensions of wrench flats and hook wrench holes that are sometimes necessary for the assembly of the cylinder piston rod's threaded end to accessories.

2 Normative references

The following referenced documents are indispensable for the application of this document. For dated references, only the edition cited applies. For undated references, the latest edition of the referenced document (including any amendments) applies.

ISO 5598, *Fluid power systems and components — Vocabulary*

ISO 6099, *Fluid power systems and components — Cylinders — Identification code for mounting dimensions and mounting types*

3 Terms and definitions

For the purposes of this document, the terms and definitions given in ISO 5598 apply. Dimension letter symbols are in accordance with ISO 6099.

4 Types and dimensions for hydraulic cylinder piston rod ends

4.1 Piston rod thread types and dimensions

Piston rod thread types for hydraulic cylinders shall be chosen from Figures 1, 2 and 3. Piston rod threads shall conform to the dimensions given in Tables 1 and 2.

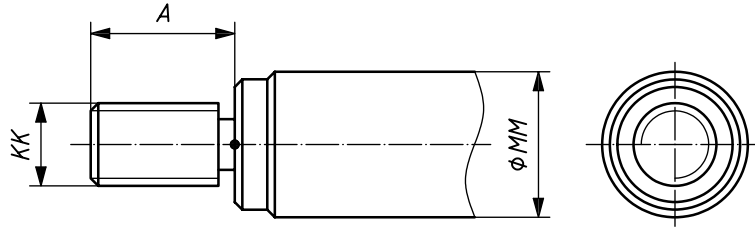

Figure 1 — Male thread with shoulder for hydraulic cylinder piston rods

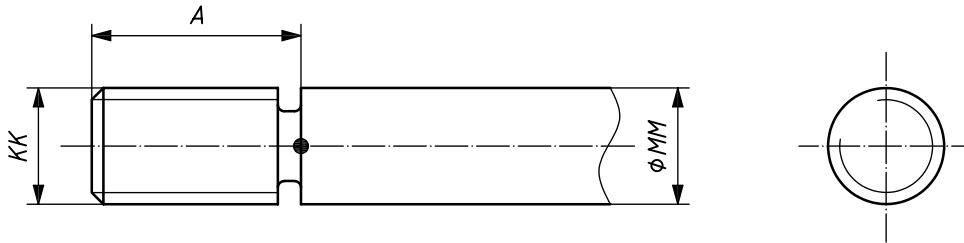

Figure 2 — Male thread without shoulder for hydraulic cylinder piston rods

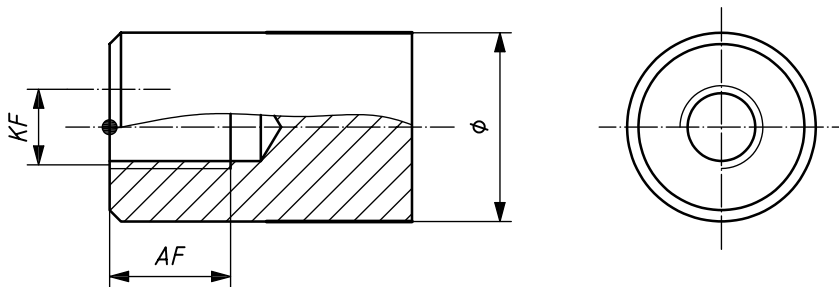

Figure 3 — Female thread for hydraulic cylinder piston rods

Table 1 — Thread sizes and thread lengths for male threads for hydraulic cylinder piston rods

Dimensions in millimetres

Thread sizes <i>KK</i>	Thread length <i>A</i> ^a	
	Short type	Long type ^{b,c}
M10 × 1,25	14	22
M12 × 1,25	16	24
M14 × 1,5	18	28
M16 × 1,5	22	32
M18 × 1,5	25	36
M20 × 1,5	28	40
M22 × 1,5	30	44
M24 × 2	32	48
M27 × 2	36	54
M30 × 2	40	60
M33 × 2	45	66
M36 × 2	50	72
M42 × 2	56	84
M48 × 2	63	96
M56 × 2	75	112
M64 × 3	85	128
M72 × 3	90	128
M80 × 3	95	140
M90 × 3	106	160
M100 × 3	112	—
M110 × 3	112	—
M125 × 4	125	—
M140 × 4	140	—
M160 × 4	160	—
M180 × 4	180	—
M200 × 4	200	—
M220 × 4	220	—
M250 × 6	250	—
M280 × 6	280	—
<p>^a Thread length, <i>A</i>, is a maximum measure.</p> <p>^b When locknuts are required for adjustment, use the long type thread lengths. Bending loads shall be taken into consideration.</p> <p>^c For long type threads not specified in this table, the ratio between the long type and short type shall be at least 1,5.</p>		

Table 2 — Thread sizes and thread lengths of female threads for hydraulic cylinder piston rods

Dimensions in millimetres

Thread sizes <i>KF</i>	Minimum thread length <i>AF</i> ^a
M8 × 1	12
M10 × 1,25	14
M12 × 1,25	16
M16 × 1,5	22
M20 × 1,5	28
M27 × 2	36
M33 × 2	45
M42 × 2	56
M48 × 2	63
M64 × 3	85
M80 × 3	95
M100 × 3	112
M125 × 4	125
M160 × 4	160
^a Thread length <i>AF</i> is a minimum measure.	

4.2 Wrench flat and hook wrench hole types and dimensions

A minimum of two wrench flats or hook wrench holes shall be used if necessary for the assembly of the hydraulic cylinder piston rod's threaded end to accessories, and their style shall be chosen from Figures 4, 5 or 6. Wrench flats or hook wrench holes shall conform to the dimensions given in Table 3.

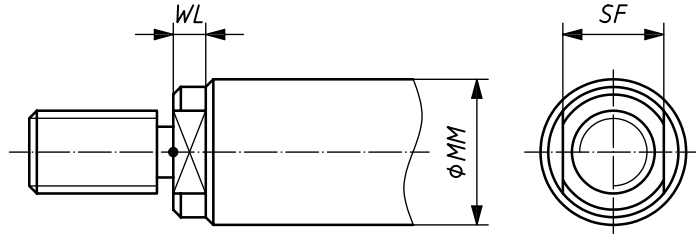

Figure 4 — Wrench flats for a hydraulic cylinder piston rod end (male thread)

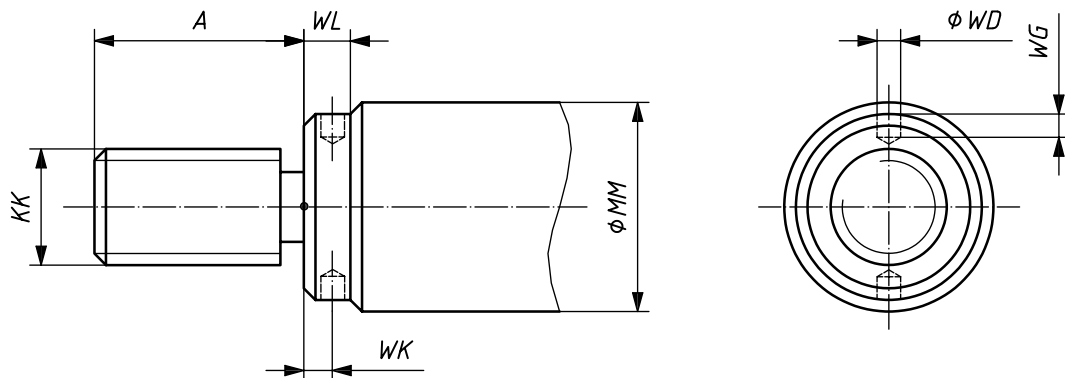

Figure 5 — Hook wrench holes for a hydraulic cylinder piston rod end

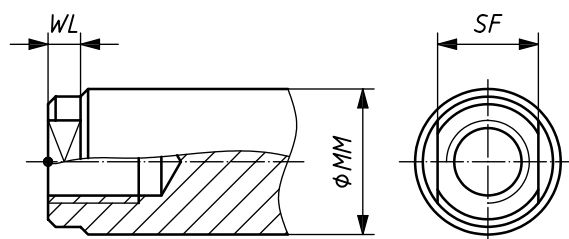

Figure 6 — Wrench flats for a hydraulic cylinder piston rod end (female thread)

Table 3 — Dimensions of wrench flats and hook wrench holes for hydraulic cylinder piston rods

Dimensions in millimetres

<i>MM</i> ^a	Wrench flats	Hook wrench holes			Wrench flats or hook wrench holes
	<i>SF</i> h14	<i>WD</i> min.	<i>WG</i> min.	<i>WK</i> min.	<i>WL</i> min.
12	10	2	2,5	2,5	5
14	12	2	2,5	2,5	5
16	13	2,5	4,5	2,5	5
18	15	2,5	4,5	2,5	5
20	17	2,5	4,5	2,5	5
22	19	2,5	4,5	2,5	5
25	22	3	5	4	7
28	22	3	5	4	7
32	27	4	6	4	8
36	30	4	6	5	8
40	34	4	6	5	10
45	41	5	7	6	10
50	46	5	7	6	10
56	50	5	7	6	10
63	55	5	7	6	10
70	60	6	8	6	10
80	65	6	8	6	15
90	80	6	8	6	15
100	85	8	10	6	15
110	100	8	10	6	15
125	110	8	10	8	15
140	128	8	10	8	15
160	140	8	10	8	18
180	160	10	12	11	25
200	—	10	12	11	25
220	—	10	12	11	25

^a In accordance with ISO 3320.

5 Types and dimensions for pneumatic cylinder piston rod ends

5.1 Piston rod thread types and dimensions

Piston rod thread types for pneumatic cylinders shall be chosen from Figures 7, 8 or 9. Piston rod male and female threads shall conform to the dimensions given in Table 4.

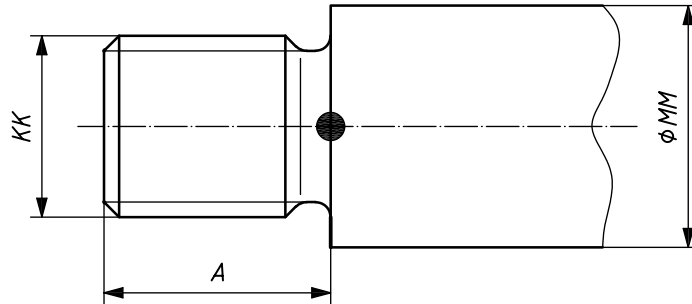

Figure 7 — Male thread with shoulder for pneumatic cylinder piston rods

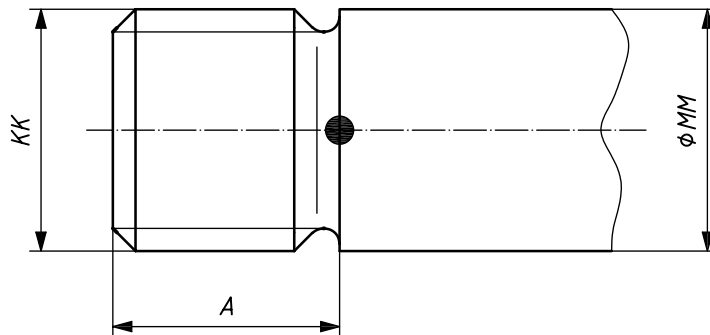

Figure 8 — Male thread without shoulder for pneumatic cylinder piston rods

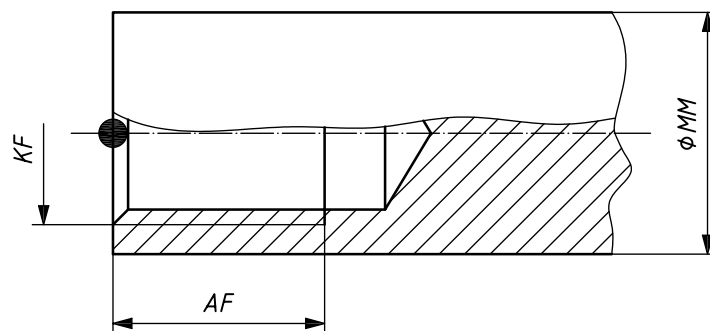

Figure 9 — Female thread for pneumatic cylinder piston rods

Table 4 — Thread sizes and thread lengths of male and female threads for pneumatic cylinder piston rods

Male thread				Female thread	
Thread sizes <i>KK</i>	Thread length <i>A</i>			Thread sizes <i>KF</i>	Thread length <i>AF</i>
	Short type	Middle type	Long type		
M3	6	8	9	M3	6
M4	8	10	12	M4	8
M5	10	12	15	M5	10
M6	12	14	16	M6	10
M8	12	16	20	M8	12
—	—	—	—	M10	16
M10 × 1,25	14	19	22	—	—
—	—	—	—	M12	20
M12 × 1,25	16	22	24	—	—
M14 × 1,5	18	23	28	—	—
—	—	—	—	M16	25
M16 × 1,5	22	28	32	—	—
M18 × 1,5	25	30	36	—	—

5.2 Wrench flat and hook wrench hole types and dimensions

Wrench flats and hook wrench holes are not required for pneumatic cylinders that conform to International Standards. However, for certain pneumatic cylinder applications, manufacturers may use the dimensions given in Table 3 of this International Standard.

6 Identification statement (reference to this International Standard)

It is strongly recommended to manufacturers who have chosen to conform to this International Standard that the following statement be used in test reports, catalogues and sales literature:

“Selection of hydraulic or pneumatic cylinder piston rod end dimensions and types is in accordance with ISO 4395, *Fluid power systems and components — Cylinder piston rod end types and dimensions.*”

Bibliography

- [1] ISO 3320, *Fluid power systems and components — Cylinder bores and piston rod diameters — Metric series*

