

**INTERNATIONAL STANDARD****4337**

INTERNATIONAL ORGANIZATION FOR STANDARDIZATION • МЕЖДУНАРОДНАЯ ОРГАНИЗАЦИЯ ПО СТАНДАРТИЗАЦИИ • ORGANISATION INTERNATIONALE DE NORMALISATION

## Information processing — Interchangeable magnetic twelve-disk pack (100 Mbytes)

*Traitement de l'information — Chargeur magnétique interchangeable à douze disques  
(100 mégaoctets)*

First edition — 1977-10-01

UDC 681.327.63

Ref. No. ISO 4337-1977 (E)

**Descriptors:** data processing, data processing equipment, disk packs, specifications, physical properties, dimensions, magnetic properties, recording tracks, interchangeability.

Price based on 40 pages

## FOREWORD

ISO (the International Organization for Standardization) is a worldwide federation of national standards institutes (ISO member bodies). The work of developing International Standards is carried out through ISO technical committees. Every member body interested in a subject for which a technical committee has been set up has the right to be represented on that committee. International organizations, governmental and non-governmental, in liaison with ISO, also take part in the work.

Draft International Standards adopted by the technical committees are circulated to the member bodies for approval before their acceptance as International Standards by the ISO Council.

International Standard ISO 4337 was developed by Technical Committee ISO/TC 97, *Computers and information processing*, and was circulated to the member bodies in March 1976.

It has been approved by the member bodies of the following countries :

Australia	Hungary	Romania
Belgium	Italy	South Africa, Rep. of
Brazil	Japan	Spain
Bulgaria	Netherlands	Switzerland
Czechoslovakia	New Zealand	Turkey
France	Philippines	United Kingdom
Germany	Poland	Yugoslavia

The member body of the following country expressed disapproval of the document on technical grounds :

U.S.A.

<b>CONTENTS</b>		<b>Page</b>
1	Scope and field of application . . . . .	1
<b>SECTION ONE : GENERAL DESCRIPTION . . . . .</b>		<b>1</b>
2	General description . . . . .	1
<b>SECTION TWO : MECHANICAL AND PHYSICAL CHARACTERISTICS . . . . .</b>		<b>2</b>
3	General requirements . . . . .	2
4	Dimensional characteristics . . . . .	2
5	Physical characteristics . . . . .	5
<b>SECTION THREE : MAGNETIC CHARACTERISTICS . . . . .</b>		<b>7</b>
6	Track and recording information — Data surfaces . . . . .	7
7	Test conditions and equipment — Data surfaces . . . . .	7
8	Functional testing — Data surfaces . . . . .	10
9	Acceptance criteria for data surface . . . . .	11
10	Servo surface . . . . .	11
<b>SECTION FOUR : PRE-INITIALIZATION . . . . .</b>		<b>16</b>
11	Data track pre-initialization . . . . .	16
<b>Annexes</b>		
A	Air cleanliness class 100 . . . . .	31
B	Measurement of track width . . . . .	32
C	ECC implementation . . . . .	33
D	General track format . . . . .	35

# Information processing — Interchangeable magnetic twelve-disk pack (100 Mbytes)

## 1 SCOPE AND FIELD OF APPLICATION

This International Standard specifies the general, physical, and magnetic characteristics and the pre-initialization for the physical interchange of 100 Mbytes magnetic twelve-disk packs, for use in electronic data processing systems.

## SECTION ONE : GENERAL DESCRIPTION

### 2 GENERAL DESCRIPTION

#### 2.1 General figures

A typical twelve-disk pack is represented in figures 1 to 6 :

- figure 1 shows an exploded view;
- figure 2 shows a vertical cross-section;
- figure 3 shows, at an enlarged scale, the relationship between the top cover and the bottom protective disk;
- figure 4 shows a schematic cross-section of part of the disk pack;
- figure 5 shows a schematic cross-section of the spindle lock;
- figure 6 shows an enlarged view of the edge of a disk.

#### 2.2 Main elements

The main elements of this twelve-disk pack are :

- the top cover;
- the hub;
- the spindle lock;

- the protective disks;
- the recording disks;
- the servo surface;
- the bottom cover.

Other elements shown in the drawings are for better understanding of the figures only and are not part of the standard.

#### 2.3 Direction of rotation

The disk pack shall rotate counter-clockwise when viewed from the top.

#### 2.4 Pack capacity

A gross information capacity of 100 million 8-bit bytes is achieved in this 12-disk pack by the use of 19 data disk surfaces. Data are recorded on 404 tracks per data surface. The track spacing gives approximately 8 tracks per millimetre, each containing a maximum of 13 030 8-bit bytes of information. The recording density varies between outer and inner tracks and reaches a maximum of 159 bpmm on the innermost track.

## SECTION TWO : MECHANICAL AND PHYSICAL CHARACTERISTICS

## 3 GENERAL REQUIREMENTS

## 3.1 Operation and storage environment

## 3.1.1 Operation

The operating temperature — measured within the disk pack area of the drive — shall be within the range 15 °C (59 °F) to 57 °C (135 °F) at a relative humidity of 8 to 80 %. The wet bulb reading shall not exceed 26 °C (79 °F). Before a disk pack is placed into operation, it shall be conditioned within its covers for a minimum of 2 h in the same environment as that in which the disk drive is operating.

The time of acclimatization is dependent on the difference between the disk pack temperature and the environmental temperature of the disk drive. The minimum time may be calculated using a temperature gradient of 10 °C (18 °F) per hour.

The range specified above does not necessarily apply to the disk drive.

## 3.1.2 Storage

The storage temperature shall be within the range -40 °C (-40 °F) to +65 °C (+150 °F), the wet bulb reading not exceeding 30 °C (86 °F). For wet bulb temperatures between 0,5 °C (33 °F) and 30 °C (86 °F) the disk pack shall be able to withstand a relative humidity of 8 % to 80 %.

It is recommended that the pack should not be stored under the extreme conditions of the above range. A temperature gradient of more than 10 °C (18 °F) per hour should be avoided.

The ambient stray magnetic field intensity shall not exceed 4 000 A/m.

## 3.2 Test conditions

Unless otherwise stated, measurements shall be carried out at 23 ± 3 °C (73,4 ± 5 °F), 40 % to 60 % relative humidity after 24 h of acclimatization. Tests shall be carried out with the disk pack in the upright position, unless otherwise stated.

## 3.3 Shock and vibration

The disk pack should withstand exposure to shock and/or vibration during normal operator usage and still meet all dimensional and functional specifications of this International Standard. Protection against shock and vibration during transportation and storage shall be subject to agreement between supplier and user.

## 3.4 Material

Unless otherwise stated, the disk pack may be constructed from any suitable material so long as the dimensional,

inertial and other functional requirements of this International Standard are maintained. The coefficient of thermal expansion of all the recording disks shall be the same.

## 4 DIMENSIONAL CHARACTERISTICS

## 4.1 Reference plane

All dimensions are referred to a reference plane. It is the surface, perpendicular to the axis of the pack, on which the pack rests with its three rest buttons.

## 4.2 Overall external dimensions

## 4.2.1 Overall height (see figure 2)

The overall height of the disk pack with top and bottom cover shall be

$$h_1 \leq 180 \text{ mm (7.09 in.)}$$

## 4.2.2 Overall diameter (see figure 2)

The overall diameter of the disk pack with top and bottom cover shall be

$$d_1 \leq 381 \text{ mm (15.0 in.)}$$

## 4.3 Top cover (see figure 3)

## 4.3.1 Outside radius, pack-centreline relationship

When measured with reference to the hub centreline the outside radius of the top cover shall be

$$183,65 \text{ mm (7.230 in.)} < r_1 < 185,42 \text{ mm (7.300 in.)}$$

## 4.3.2 Vertical distance

The vertical distance of the lower edge of the top cover below the reference plane shall be

$$h_2 = 3,56 \pm 1,47 \text{ mm (0.140} \pm 0.058 \text{ in.)}$$

## 4.4 Hub (see figure 4)

## 4.4.1 Diameter of the flexure pads

The diameter of the three hub flexure pads shall be

$$d_2 = 44,432 \pm 0,005 \text{ mm (1.749 3} \pm 0,000 2 \text{ in)}$$

measured at 20,0 ± 0,5 °C (68 ± 1 °F).

## 4.4.2 Height of the flexure pads

The height of the hub flexure pads shall be

$$h_3 = 1,91 \pm 0,13 \text{ mm (0.075} \pm 0.005 \text{ in.)}$$

#### 4.4.3 Finish of the flexure pads

The finish shall be of class N5, i.e.  $0,4 \mu\text{m}$  ( $16 \mu\text{in}$ ) arithmetical mean deviation; see ISO 1302.

#### 4.4.4 Relief of the flexure pads

The hub flexure pad shall be relieved to

$$d_3 = 44,478 \pm 0,015 \text{ mm } (1.751 \pm 0.0006 \text{ in})$$

measured at  $20,0 \pm 0,5 \text{ }^\circ\text{C}$  ( $68 \pm 1 \text{ }^\circ\text{F}$ ).

#### 4.4.5 Height of flexure pads from the reference plane

The height of the flexure pads from the reference plane shall be

$$h_4 = 1,40 \pm 0,30 \text{ mm } (0.055 \pm 0.012 \text{ in}).$$

#### 4.4.6 Radial compliance of flexure pads

The radial compliance of each flexure pad shall be  $1,0 \pm 0,2 \mu\text{m}$  ( $40 \pm 8 \mu\text{in}$ ) per  $4,5 \text{ N}$  ( $1 \text{ lbf}$ ) radial force located at the collet flexure pad with  $d_2$  expanded to  $44,450 \pm 0,0025 \text{ mm}$  ( $1.7500 \pm 0.0001 \text{ in}$ ).

#### 4.4.7 Rest buttons

##### 4.4.7.1 LOCATION

The three rest buttons shall be equally spaced on a circle of diameter

$$d_4 = 139,70 \pm 0,13 \text{ mm } (5.500 \pm 0.005 \text{ in}).$$

##### 4.4.7.2 DIAMETER AND SHAPE

The diameter of the rest buttons shall be

$$d_5 = 11 \pm 1 \text{ mm } (0.43 \pm 0.04 \text{ in}).$$

Their rest surface shall be spherical with a radius

$$r_2 = 110 \pm 15 \text{ mm } (4.33 \pm 0.59 \text{ in}).$$

##### 4.4.7.3 ROUGHNESS AND HARDNESS

The finish of the rest surfaces shall be of class N4, i.e.  $0,2 \mu\text{m}$  ( $8 \mu\text{in}$ ) arithmetical mean deviation; see ISO 1302. The hardness shall be 55 to 60 HRC (Rockwell scale C).

#### 4.5 Spindle lock (see figure 5)

##### 4.5.1 Thread of the spindle lock

The thread of the spindle lock shall be a double lead thread of type 24 UNF-2A.

##### 4.5.2 Diameter of the lower part of the spindle lock

The diameter of the lower part of the spindle lock shall be

$$d_6 = 9,37 \pm 0,13 \text{ mm } (0.369 \pm 0.005 \text{ in}).$$

##### 4.5.3 Minimum full thread length

The full thread length of the spindle lock shall be

$$h_5 \geq 7,14 \text{ mm } (0.281 \text{ in}).$$

##### 4.5.4 Chamfer

The lower end of the spindle lock shall be chamfered from an inner diameter

$$d_7 = 8,00 \pm 0,13 \text{ mm } (0.315 \pm 0.005 \text{ in})$$

and an angle

$$\gamma = 45^\circ \pm 2^\circ.$$

##### 4.5.5 Location of the shoulder of the spindle lock

The shoulder of the spindle lock shall be at a distance from the reference plane of

$$h_6 = 13,51 \begin{matrix} + 0,23 \\ - 0,30 \end{matrix} \text{ mm } (0.532 \begin{matrix} + 0.009 \\ - 0.012 \end{matrix} \text{ in}).$$

##### 4.5.6 Length of the lower part of the spindle lock

The length of the lower part of the spindle lock shall be

$$h_7 = 19,15 \pm 0,076 \text{ mm } (0.754 \pm 0.003 \text{ in}).$$

##### 4.5.7 Maximum diameter of the lower part of the spindle lock

The diameter of the lower part of the spindle lock with the safety balls expanded shall be

$$d_8 = 10,7 \pm 0,1 \text{ mm } (0.421 \pm 0.004 \text{ in}).$$

The safety balls shall not expand before the lockshaft pin is at a distance of

$$h_8 \leq 16,97 \text{ mm } (0.668 \text{ in})$$

from the shoulder of the spindle lock. The safety balls shall cease to expand when the lockshaft pin is at a distance of

$$h_9 \geq 14,65 \text{ mm } (0.577 \text{ in})$$

from the shoulder of the spindle lock.

The diameter with relaxed balls shall be

$$d_9 \leq 9,53 \text{ mm } (0.375 \text{ in}).$$

##### 4.5.8 Location of the safety balls

The centres of the safety balls shall be located with regard to the spindle lock shoulder at a distance of

$$h_{10} = 9,04 \pm 0,23 \text{ mm } (0.356 \pm 0.009 \text{ in}).$$

##### 4.5.9 Hole for the penetration of the lockshaft pin

The diameter of the hole for the penetration of the drive spindle lockshaft pin into the spindle lock shall be

$$d_{10} = 3,18 \pm 0,13 \text{ mm } (0.125 \pm 0.005 \text{ in}).$$

**4.5.10 Depth of penetration of the lockshaft pin**

The clearance for the penetration of the drive spindle lockshaft pin into the spindle lock shall extend to a distance of

$$h_{11} \leq 13,84 \text{ mm (0.545 in)}$$

from the shoulder.

**4.5.11 Removal of the top cover**

It shall be possible to remove the top cover when the lockshaft has penetrated into the spindle lock to a distance of

$$h_{12} = 14,44 \pm 0,21 \text{ mm (0.569} \pm 0.008 \text{ in)}$$

from the shoulder.

**4.6 Bottom protective disk (see figure 4)****4.6.1 Diameter**

The diameter of the bottom protective disk shall be

$$d_{11} = 360,37 \pm 0,25 \text{ mm (14.188} \pm 0.010 \text{ in)}.$$

**4.6.2 Thickness**

The thickness of the bottom protective disk shall be

$$e_1 = 1,30 \pm 0,08 \text{ mm (0.051} \pm 0.003 \text{ in)}.$$

**4.7 Disk supports (see figure 4)**

The radius of all disk supports shall be

$$r_3 \leq 90,0 \text{ mm (3.58 in)}.$$

**4.8 Recording disks****4.8.1 Diameter (see figure 4)**

The diameter of all recording disks shall be

$$d_{12} = 356,25 \pm 0,15 \text{ mm (14.025} \pm 0.006 \text{ in)}.$$

**4.8.2 Thickness (see figure 6)**

The thickness of all recording disks shall be

$$e_2 = 1,905 \pm 0,025 \text{ mm (0.075} \pm 0.001 \text{ in)}.$$

**4.8.3 Disk edge chamfer (see figure 6)**

For a distance

$$b \leq 1,3 \text{ mm (0.05 in)}$$

from the outside edge of the disk, the disk contour shall be relieved within the extended boundaries of the disk surfaces.

**4.9 Top protective disk (see figure 4)****4.9.1 Diameter**

The diameter of the top protective disk shall be

$$d_{12} = 356,25 \pm 0,15 \text{ mm (14.025} \pm 0.006 \text{ in)}.$$

**4.9.2 Thickness**

The thickness of the top protective disk shall be

$$e_4 = 1,27 \pm 0,05 \text{ mm (0.050} \pm 0.002 \text{ in)}.$$

**4.10 Location of the disks (see figure 4)**

The disks shall be located with regard to the reference plane as described in 4.10.1 to 4.10.3.

**4.10.1 Bottom protective disk**

The distance between the reference plane and the lower surface of the bottom protective disk shall be

$$h_{13} = 0,56 \text{ to } 1,41 \text{ mm (0.022 to 0.056 in)}.$$

**4.10.2 Recording disks**

The distance above the reference plane to the recording disks shall be

$$h_{14} = 10,478 \pm 0,203 \text{ mm (0.412 5} \pm 0.008 \text{ in)},$$

$$h_{15} = 20,003 \pm 0,203 \text{ mm (0.787 5} \pm 0.008 \text{ in)},$$

$$h_{16} = 29,528 \pm 0,203 \text{ mm (1.162 5} \pm 0.008 \text{ in)},$$

$$h_{17} = 39,053 \pm 0,203 \text{ mm (1.537 5} \pm 0.008 \text{ in)},$$

$$h_{18} = 48,578 \pm 0,203 \text{ mm (1.912 5} \pm 0.008 \text{ in)},$$

$$h_{19} = 58,103 \pm 0,203 \text{ mm (2.287 5} \pm 0.008 \text{ in)},$$

$$h_{20} = 67,628 \pm 0,203 \text{ mm (2.662 5} \pm 0.008 \text{ in)},$$

$$h_{21} = 77,153 \pm 0,203 \text{ mm (3.037 5} \pm 0.008 \text{ in)},$$

$$h_{22} = 86,678 \pm 0,203 \text{ mm (3.412 5} \pm 0.008 \text{ in)},$$

$$h_{23} = 96,203 \pm 0,203 \text{ mm (3.787 5} \pm 0.008 \text{ in)}.$$

**4.10.3 Top protective disk**

The distance between the reference plane and the lower surface of the top protective disk shall be

$$h_{24} = 105,982 \pm 0,432 \text{ mm (4.172 5} \pm 0.017 \text{ in)}.$$

**4.11 Location of the lowest element**

The lowest element of the disk pack shall not extend outside an annular space defined by

$$h_{25} \leq 7,6 \text{ mm (0.30 in)}$$

and two radii

$$r_4 = 78,0 \text{ mm (3.07 in)},$$

$$r_5 = 96,5 \text{ mm (3.80 in)}.$$

#### 4.12 Height without covers

The overall height of the disk pack, without covers, above the reference plane shall be

$$h_{26} \leq 123,0 \text{ mm (4.84 in.)}$$

#### 4.13 Hub/disk relationship

##### 4.13.1 Axial position limits of disk surfaces

With the disk pack revolving at any speed in the range 2 500 to 3 700 rev/min, the axial runout of the recording disks and the top and bottom protective disks (defined by stacking dimension  $h_{13}$  through  $h_{24}$  in figure 4) shall remain within the axial position limits defined for each surface by the plus and minus tolerance around the datum dimension expressed as a dimension from the reference plane for that surface (dimensions  $h_{13}$  through  $h_{24}$ ). This requirement shall apply to the area of all disk surfaces between a radius of 175,08 mm (6.893 in) minimum and a radius of 98,42 mm (3.875 in) maximum.

##### 4.13.2 Axial runout of disks

The axial runout of any disk at any rotational frequency up to the maximum allowable rotational frequency (see 5.3) shall not exceed

- 0,15 mm (0.006 in) for the recording disks,
- 0,51 mm (0.020 in) for the protective disks,

total indicator reading.

##### 4.13.3 Acceleration of axial runout

With the disk pack revolving at  $3\,600 \pm 72 \text{ min}^{-1}$ , the acceleration of the axial runout of the recording disk surfaces (measured with a high frequency cutoff defined by the flat response/high frequency asymptote intercept of 2 200 Hz and a high frequency fall-off of 18 dB per octave) in the area between a radius of 175,08 mm (6.893 in) minimum and a radius of 98,42 mm (3.875 in) maximum shall not exceed a peak acceleration from the base line of  $\pm 76 \text{ m/s}^2 (\pm 3\,000 \text{ in/s}^2)$ .

##### 4.13.4 Horizontal runout of disks

The horizontal runout (i.e. the total indicator reading) shall not exceed 0,25 mm (0.010 in) for the recording disks, and 0,51 mm (0.020 in) for the top and bottom protective disks, referred to the centreline of the disk pack hub.

##### 4.13.5 Angular shift between disks and hub

After the disk pack has experienced a positive or negative acceleration up to  $3\,000 \text{ rad/s}^2$ , the angular shift between disks and hub must remain equal to zero when measured with a device capable of detecting a shift of  $3''$  of arc.

#### 4.14 Location of magnetic surfaces

The area of the magnetic surface of the recording disks shall extend from an inside diameter of 190,5 mm (7.50 in) maximum to an outside diameter of 352,0 mm (13.86 in) minimum.

## 5 PHYSICAL CHARACTERISTICS

### 5.1 Moment of inertia

The moment of inertia of the disk pack without covers shall not exceed  $107 \text{ g}\cdot\text{m}^2 (365.6 \text{ lb}\cdot\text{in}^2)$ .

### 5.2 Balance

The disk pack shall be dynamically balanced. Residual unbalance shall be less than  $100 \text{ g}\cdot\text{mm} (0.14 \text{ oz}\cdot\text{in})$  when measured at  $3\,600 \text{ min}^{-1}$  in each of two planes parallel to the disk surface at  $5,84 \pm 1,3 \text{ mm} (0.23 \pm 0.05 \text{ in})$  above the upper surface of the top protective disk and below the lower surface of the bottom protective disk, respectively.

### 5.3 Maximum rotational frequency

The disk pack shall be capable of withstanding the effect of stress at a rotational frequency of  $3\,700 \text{ min}^{-1}$  counter-clockwise as viewed from the top.

### 5.4 Locking pull

The disk pack shall be held to the disk drive spindle by a force of  $1\,550 \pm 450 \text{ N} (350 \pm 100 \text{ lbf})$ , exerted by the downward pull of the disk drive lockshaft on the disk pack spindle lock.

### 5.5 Ambient air

#### 5.5.1 Filtered air

The filtered air in the immediate area of the disk pack shall be equivalent to a class 100 clean room (see annex A).

#### 5.5.2 Pressure

The static pressure in the immediate area of the disk pack shall be  $0,25 \text{ mbar} (0.1 \text{ inH}_2\text{O})$  minimum above the environment of the drive.

### 5.6 Thermal time constant

The thermal time constant is the time required to reduce an initial temperature difference between the pack and the drive by  $2/3$ . The disk pack thermal time constant shall not exceed 1 min when measured with the disk pack rotating at  $3\,600 \pm 72 \text{ min}^{-1}$  and within the specified operating environment and conditions.

### 5.7 Electrical earthing

The disk pack shall provide a discharge path from the magnetic media to the drive spindle through the hub mechanism.

### 5.8 Physical characteristics of magnetic surfaces

#### 5.8.1 Surface roughness

The finished magnetic surface shall have a surface roughness less than  $0,05 \mu\text{m} (2.0 \mu\text{in})$ , arithmetic average, with a maximum deviation in height of  $0,38 \mu\text{m} (15 \mu\text{in})$  from



average, when measured with a 2,5  $\mu\text{m}$  (0,000 1 in) stylus and a 750  $\mu\text{m}$  (0.03 in) cutoff range.

## 5.8.2 Durability of magnetic surfaces

### 5.8.2.1 RESISTANCE TO CHEMICAL CLEANING FLUID

The magnetic surface of recording disks shall not be adversely affected by a 91 % solution of isopropyl alcohol (made from reagent grade isopropyl alcohol mixed with 9 %

distilled or deionized water by volume) when used for cleaning.

### 5.8.2.2 COATING ADHESION

The nature of the coating shall be such as to ensure wear resistance under operating conditions and maintenance of adhesion and abrasive wear resistance.

### 5.8.2.3 ABRASIVE WEAR RESISTANCE

The coating shall be able to withstand operational wear.

## SECTION THREE : MAGNETIC CHARACTERISTICS

**6 TRACK AND RECORDING INFORMATION – DATA SURFACES****6.1 General geometry, surfaces and heads**

Head and surface details shall be as in figures 7 and 13.

Track locations shall be referred to a Cartesian co-ordinate system, axes  $X$  and  $Y$ , with its origin on the axis of rotation of the disk pack.

**6.2 Track geometry****6.2.1 Number of tracks**

There shall be 411 discrete concentric tracks per data surface.

**6.2.2 Width of tracks**

The recorded track width on the data surface shall be

$$0,109 \pm 0,005 \text{ mm (0.004 3} \pm 0.000 2 \text{ in).}$$

(A suggested method of measuring the track width is shown in annex B.)

**6.2.3 Track location**

The centreline of any track shall lie within

$$\pm 0,005 \text{ mm (0.000 2 in)}$$

of its corresponding data track centreline as defined in 10.1.5.3.

The incremental head movement and its tolerance are defined by the servo track information and shall correspond to the servo track spacing (see 10.1.5.4).

**6.2.4 Location of the lines of access**

There shall be two groups of heads each having a line of access A and B respectively. These lines of access shall be parallel to the  $X$  axis and shall have the ordinate

$$Y_A = + 7,772 \text{ mm (0.306 in),}$$

$$Y_B = - 7,772 \text{ mm (0.306 in).}$$

**6.2.5 Recording offset angle**

At the instant of writing or reading a magnetic transition, the transition may have an angle of

$$\pm 30' \text{ maximum}$$

with the line of access.

**6.2.6 Identification of data tracks**

For the purposes of testing data tracks, the identifying system specified in 6.2.6.1 to 6.2.6.4 is used.

**6.2.6.1 DATA TRACK IDENTIFICATION**

Data track identification shall be a three-digit decimal number (000 to 410) which numbers data tracks consecutively starting at the outermost data track of each data surface.

**6.2.6.2 DATA SURFACE IDENTIFICATION**

The data surfaces shall be numbered from 00 to 18 corresponding with the head numbers (see figure 7).

**6.2.6.3 CYLINDER**

A cylinder is the set of data tracks on the data surfaces having the same data track identification.

**6.2.6.4 DATA TRACK ADDRESS**

A five-digit decimal number is used for data track address with the three most significant digits defining the cylinder address and the remaining two digits defining the data surface address.

**7 TEST CONDITIONS AND EQUIPMENT – DATA SURFACES****7.1 General conditions****7.1.1 Rotational frequency**

The rotational frequency shall be  $3\,600 \pm 72 \text{ min}^{-1}$  in any test period. Rotation shall be counter-clockwise when viewed from above.

**7.1.2 Temperature**

The temperature of the air entering the disk pack area shall be

$$27 \pm 2 \text{ }^\circ\text{C (81} \pm 4 \text{ }^\circ\text{F).}$$

**7.1.3 Relative humidity**

The relative humidity of the air entering the disk pack shall be between 30 and 70 %.

**7.1.4 Conditioning**

Before starting measurements, the disk pack shall be conditioned for 24 h in the same environment as that in which the test equipment is operating.

**7.2 Standard reference data surface****7.2.1 Characteristics**

The standard reference data surface shall be characterized at the innermost and outermost track. When recorded at 1f

(see 7.8), using a data test head, the track average amplitude (see 7.7) shall be :

3,75 mV at track 000,

1,9 mV at track 410.

When recorded at  $2f$  (see 7.8), using a data test head, the track average amplitude (see 7.7) shall be :

2,7 mV at track 000,

1,3 mV at track 410.

### 7.2.2 Secondary standard reference data surface

This is a surface whose output is related to the standard reference data surface via calibration factors  $C_{D1}$  at  $1f$  and  $C_{D2}$  at  $2f$ .

The calibration factor  $C_D$  is defined as

$$C_D = \frac{\text{Standard reference data surface output}}{\text{Secondary standard reference data surface output}}$$

To qualify as a secondary standard reference data surface, the calibration factor  $C_D$  for such disks shall satisfy

$$0,90 \leq C_D \leq 1,10$$

at both measured tracks and at both frequencies.

## 7.3 Data test head

### 7.3.1 Description

Disk measurement shall be taken with a suitable test head<sup>1)</sup>. The test head shall be calibrated to the standard reference data surface and used for amplitude and data testing of the data surfaces.

### 7.3.2 Gap width

The width of the recording gap (measured optically) shall be

$$109,0 \pm 2,5 \mu\text{m} \quad (0.0043 \pm 0.0001 \text{ in}).$$

### 7.3.3 Gap length

The length of the recording gap shall be

$$2,54 \pm 0,63 \mu\text{m} \quad (100 \pm 25 \mu\text{in}).$$

### 7.3.4 Offset angle

The angle between the read gap in the ferrite core and the line of access shall be

$$0^\circ \pm 30'.$$

### 7.3.5 Flying height

When flying over track 410, the test head shall have a flying height at the gap of

$$1,14 \pm 0,05 \mu\text{m} \quad (45 \pm 2 \mu\text{in}).$$

### 7.3.6 Inductance

The total head inductance shall be  $9,4 \pm 0,2 \mu\text{H}$  measured in air at 1 MHz. One leg shall have an inductance of  $2,70 \pm 0,05 \mu\text{H}$ ; the other leg shall have an inductance of  $2,85 \pm 0,05 \mu\text{H}$ .

### 7.3.7 Resonant frequency

As measured at the head cable connector, the resonant frequency of the head shall be

$$19,5 \pm 0,5 \text{ MHz}.$$

### 7.3.8 Resolution

The test head resolution shall lie between 65 and 79 % at track 000, and between 61 % and 75 % at track 410. Resolution is defined as

$$\frac{2f \text{ amplitude}}{1f \text{ amplitude}} \times 100 \%$$

### 7.3.9 Head loading force

The net head loading force shall be such as to achieve the flying height given in 7.3.5 and shall be within the limits

$$3,4 \pm 0,4 \text{ N} \quad (0.76 \pm 0.09 \text{ lbf}).$$

### 7.3.10 Calibration factor

The data test head calibration factors  $C_{H1}$  at  $1f$  and  $C_{H2}$  at  $2f$  shall satisfy

$$0,90 \leq C_H \leq 1,10.$$

$C_H$  is defined by

$$C_H = \frac{\text{Standard reference data surface output}}{\text{Actual head voltage measured}}$$

when measured on a standard reference data surface, or by

$$C_H = \frac{\text{Standard reference data surface output}}{(\text{Actual head voltage measured}) \times C_D}$$

when measured on a secondary standard reference data surface.

### 7.3.11 Overwrite capability

The overwrite capability of the head shall meet the following requirement.

Write with  $1f$  on track 000 of a standard reference data surface and measure the average amplitude of the  $1f$  signal with a frequency-selective voltmeter. Without DC erase, overwrite once at  $2f$ , measure the average amplitude of the residual  $1f$  signal.

<sup>1)</sup> Information on suitable test heads may be obtained from the Secretariat of ISO/TC 97, or from the ISO Central Secretariat.

The ratio :

$$\frac{\text{Average amplitude of selectively measured } 1f \text{ signal after overwrite with } 2f}{\text{Average amplitude of selectively measured } 1f \text{ signal before overwrite with } 2f}$$

shall be  $-50 \pm 5$  dB.

## 7.4 Conditions for measurements using the data test head

### 7.4.1 Write current

The  $2f$  write current shall conform to figure 8. The current amplitude measured at the head termination connector shall be varied in seven levels as presented below :

Data tracks	Write current amplitude ( $I_{W1} + I_{W2}$ )	
0 to 63	180 mA	} tolerance $\pm 1$ %
64 to 127	173 mA	
128 to 191	166 mA	
192 to 255	160 mA	
256 to 319	153 mA	
320 to 383	147 mA	
384 to 410	140 mA	

The differences between the positive and negative amplitudes of the quiescent write current shall be  $|I_{W1} - I_{W2}| < 2$  mA.

$$T_R = 46 \pm 3 \text{ ns,}$$

$$T_F = 46 \pm 3 \text{ ns.}$$

Overshoot :  $(6,5 \pm 0,5) \% \text{ of } I_W = \frac{I_{W1} + I_{W2}}{2}$ ,

$$T_1 = T_2 \pm 2 \%.$$

### 7.4.2 DC erase current

The DC erase current supplied to one of the two read/write coils when DC erase is specified shall be :

Data tracks	DC erase current	
0 to 63	90,0 mA	} tolerance $\pm 1$ %
64 to 127	86,5 mA	
128 to 191	83,0 mA	
192 to 255	80,0 mA	
256 to 319	76,5 mA	
320 to 383	73,5 mA	
384 to 410	70,0 mA	

## 7.5 Read channel

### 7.5.1 Input impedance

The differential input impedance of the read channel shall be  $900 \pm 45 \Omega$  in parallel with  $25 \pm 2$  pF, including the pre-amplifier input impedance and all other distributed and lumped impedance measured at the head termination connector.

### 7.5.2 Frequency and phase characteristics

The frequency and phase characteristics are defined by the following :

- the frequency response shall be flat within  $\pm 0,25$  dB from 0,1 MHz to 6,45 MHz ( $0,06f$  to  $4f$ );
- the  $-3$  dB roll-off point shall be at 9,675 MHz ( $6f$ );
- the attenuation above 9,675 MHz shall not be less than that given by a line drawn through zero at 9,675 MHz with a slope of  $-60$  dB/decade;
- the phase shift shall be less than  $\pm 5^\circ$  between 0,1 MHz and 6,45 MHz ( $0,06f$  and  $4f$ ).

### 7.5.3 Transfer characteristics

For inputs between 0,3 mV and 10,0 mV the transfer characteristic shall be linear within  $\pm 3$  % or  $50 \mu V$ , whichever is larger.

## 7.6 Automatic gain controlled amplifier

The AGC-amplifier shall produce an output voltage  $V_{AGC}$  constant to within  $\pm 1$  % for input voltages from  $V_{IN, min} = 0,3$  mV to  $V_{IN, max} = 10,0$  mV (see figure 9).

Its response time shall be  $3,4 \mu s$ . All frequencies below 10 kHz shall be attenuated at a rate of 20 dB/decade.

## 7.7 Track average amplitude $V_{TA}$

The track average amplitude  $V_{TA}$  is the average of the peak-to-peak values of the signals over one revolution of the disk measured at the output of the data test head when electrically loaded as in 7.5.

## 7.8 Test signals

The recording frequencies specified as  $1f$  and  $2f$  shall be :

$$1f = (3\,225 \pm 3,225) \times 10^3 \text{ transitions/s,}$$

$$2f = (6\,450 \pm 6,450) \times 10^3 \text{ transitions/s.}$$

## 7.9 Use of DC erase

Unless otherwise specified all write operations shall be preceded by a DC erase operation.

## 8 FUNCTIONAL TESTING – DATA SURFACES

### 8.1 Surface tests

#### 8.1.1 Amplitude test

##### 8.1.1.1 PROCEDURE

Write on any part of the data surface at  $2f$ , read back and measure the  $V_{TA}$ .

##### 8.1.1.2 RESULT

The upper limit of  $V_{TA}$  corrected by  $C_H$  for the data test head shall be 1,8 mV at data cylinder 410 and shall increase linearly to a value of 3,6 mV at data cylinder 000. The corresponding lower limit shall be 0,95 mV at data cylinder 410 and shall increase linearly to a value of 1,8 mV at data cylinder 000 (see figure 10).

##### 8.1.2 Resolution test

##### 8.1.2.1 PROCEDURE

Write on any part of the data surface at  $1f$ , read back and measure the  $V_{TA}$ . Then DC erase, write at the same position at  $2f$ , read back and again measure the  $V_{TA}$ .

##### 8.1.2.2 RESULT

In all cases the ratio

$$\frac{\text{Average track amplitude of } 2f \text{ signal}}{\text{Average track amplitude of } 1f \text{ signal}}$$

shall be  $0,70 \pm 0,20$ .

##### 8.1.3 Overwrite test

##### 8.1.3.1 PROCEDURE

Write on track 000 at  $1f$  and measure the average amplitude of the  $1f$  signal with a frequency-selective voltmeter. Without DC erase, overwrite once at  $2f$ . Measure the average amplitude of the residual  $1f$  signal with the frequency-selective voltmeter.

##### 8.1.3.2 RESULT

The ratio

$$\frac{\text{Average amplitude of } 1f \text{ signal after overwrite}}{\text{Average amplitude of } 1f \text{ signal before overwrite}}$$

shall be less than  $-40$  dB.

##### 8.1.4 Residual noise test

##### 8.1.4.1 PROCEDURE

Write on data track 410 at  $2f$ , read back and measure the  $V_{TA}$ . Then DC erase once and read back over one revolution.

##### 8.1.4.2 RESULT

Residual noise occurs if any of the following conditions is met :

The number of noise pulses exceeding	is greater than
16 %	1 700
18 %	400
20 %	90
22 %	20
24 %	5

} of  $0,5 V_{TA}$

Residual noise is not permitted.

### 8.2 Track quality test

#### 8.2.1 Positive modulation test

##### 8.2.1.1 PROCEDURE

Write on each track at  $2f$ , read back and measure the  $V_{TA}$ . With a delay of  $t_d = 1,55 \pm 0,15 \mu s$  after detecting a read pulse exceeding 125 % of  $0,5 V_{TA}$ , count all further such pulses during a time period of  $t_{pm} = 3,10 \pm 0,15 \mu s$  (see figure 11).

##### 8.2.1.2 RESULT

Positive modulation occurs if the number of counted pulses exceeds 16.

#### 8.2.2 Negative modulation test

##### 8.2.2.1 PROCEDURE

Write on each track at  $2f$ , read back and measure the  $V_{TA}$ . With a delay of  $t_d = 1,55 \pm 0,15 \mu s$  after detecting a read pulse not reaching 75 % of  $0,5 V_{TA}$ , count all further such pulses during a time period  $t_{nm} = 60 \pm 1 \mu s$  (see figure 11).

##### 8.2.2.2 RESULT

Negative modulation occurs if the number of counted pulses exceeds 256.

#### 8.2.3 Missing pulse test

##### 8.2.3.1 PROCEDURE

Write on each track at  $2f$  and read back using the AGC-amplifier.

##### 8.2.3.2 RESULT

A missing pulse is any read pulse whose amplitude is less than 55 % of the AGC output voltage ( $V_{AGC}$ ).

## 8.2.4 Extra pulse test

### 8.2.4.1 PROCEDURE

Write on each track at  $2f$ , read back and measure the  $V_{TA}$ . Then DC erase once and read back over one revolution.

### 8.2.4.2 RESULT

An extra pulse is any spurious read pulse exceeding 40 % of  $0,5 V_{TA}$ .

## 9 ACCEPTANCE CRITERIA FOR DATA SURFACES

### 9.1 Surface test criteria

The disk pack shall meet the requirements of all tests specified in 8.1.

### 9.2 Track quality criteria

#### 9.2.1 Modulation criteria

Positive or negative modulation as defined in 8.2 shall not occur in any track.

#### 9.2.2 Data errors

##### 9.2.2.1 SINGLE ERROR

A single error is the occurrence of a missing pulse (see 8.2.3) or of an extra pulse (see 8.2.4).

##### 9.2.2.2 CORRECTABLE ERROR

A correctable error occurs if the interval between the first single error and the last single error of a data track is equal to or less than 10 bit periods (see 11.1.1).

##### 9.2.2.3 UNCORRECTABLE ERROR

An uncorrectable error occurs if the interval between the first single error and the last single error of a data track is greater than 10 bit periods (see 11.1.1).

##### 9.2.2.4 ERROR CRITERIA

There shall be neither correctable nor uncorrectable errors in the tracks having the addresses 00000 and 00001. There shall be no uncorrectable errors in each track from  $93 \mu\text{s}$  to  $233,12 \mu\text{s}$  following the index.

For the purposes of data interchange there shall be no uncorrectable errors on at least 7 676 data tracks. If more data tracks without uncorrectable errors are required, this shall be subject to agreement between the supplier and the user.

## 10 SERVO SURFACE

### 10.1 General description

#### 10.1.1 Location

The servo surface shall be the upper surface of the 6th recording disk from the top. It shall be located between data surface 10 and data surface 9 (see figure 7).

#### 10.1.2 The servo surface and its task

The servo surface shall be used as a geometrical and timing reference for all other surfaces of the disk pack. The servo surface shall provide the means to implement the following features :

- head positioning and track following;
- write timing (write clock);
- index sensing;
- rotational position sensing.

#### 10.1.3 Rotational frequency

For the following dibit timing relationships a nominal rotational frequency of  $3\,600 \text{ min}^{-1}$  is assumed.

#### 10.1.4 Recorded servo tracks

##### 10.1.4.1 TWO-BYTE INTERVAL

Each recorded servo track shall be divided into 6 720 equal intervals, called 2-byte intervals (or dual intervals). Each 2-byte interval shall correspond in time  $t_1$  to two data bytes on any data surface.

$$t_1 = 2\,480 \text{ ns nominal.}$$

##### 10.1.4.2 DIBIT

The read signal of a recorded servo track shall consist of pairs of pulses called dibits. Each dibit consists of a pulse of one polarity followed closely by a pulse of the opposite polarity. The time interval  $t_2$  between these two pulses shall be small compared with  $t_1/2$  (see figure 12) and its value shall be

$$t_2 = 330 \text{ ns nominal}$$

measured at the point on the leading edge of the pulse amplitude which equals 50 % of the AGC reference amplitude (see 10.2.4).

##### 10.1.4.3 PLUS-ODD SERVO TRACK

A plus-odd servo track shall be recorded so that its read signal consists of plus-dibits occurring in the first half of the 2-byte intervals. A plus-dibit shall consist of a positive pulse followed by a negative pulse (see figure 12).

##### 10.1.4.4 MINUS-EVEN SERVO TRACK

A minus-even servo track shall be recorded so that its read

signal consists of minus-dibits occurring in the second half of the 2-byte intervals. A minus-dibit shall consist of a negative pulse followed by a positive pulse (see figure 12).

#### 10.1.4.5 POLARITY OF THE SERVO READ SIGNAL

The polarity of the read signal of a recorded servo track is defined by the condition that the outermost recorded servo track (track -12,5, outer guard zone; see 10.1.5.7) is a plus-odd servo track (see 10.1.4.3).

#### 10.1.4.6 DIRECTION OF MAGNETIZATION

Figure 12 shows the relationship between direction of magnetization of the disk and the polarity of the two types of dibits.

### 10.1.5 Servo head positions and servo track geometry

#### 10.1.5.1 LINE OF ACCESS AND ALIGNMENT OF SERVO-HEAD

The read-gap of the servo head shall move along the line of access A (see 6.2.4 and figure 13). The centreline of the servo head gap shall coincide with the line of access to the accuracy given in 6.2.5.

#### 10.1.5.2 SERVO TRACKING CENTRELINE

The servo tracking centreline for each cylinder is given by the centre of the servo head gap, with the servo head positioned on the line of access, when the read signal contains equal amplitudes of the leading peaks of plus-dibits and minus-dibits. This read signal (see figure 14) is produced by adjacent plus-odd and minus-even servo tracks (see also figure 15).

The centrelines of the written data tracks of each cylinder are determined by the corresponding servo tracking centreline and the accuracy of alignment of data heads with respect to the servo head.

#### 10.1.5.3 CO-ORDINATES OF REFERENCE TRACK

The nominal location of all data track centrelines and all servo track edges shall be calculated from the nominal co-ordinates of the centreline of data track 245 :

$$X_{245} = 129,487 \text{ mm (5.097 9 in),}$$

$$Y = 7,772 \text{ mm (0.306 0 in).}$$

#### 10.1.5.4 SERVO TRACK SPACING

The nominal spacing  $S$  between the centrelines of the servo tracks along the line of access shall be

$$S = 132,08 \mu\text{m (5 200 } \mu\text{in).}$$

This spacing  $S$  is also the nominal spacing between the data track centrelines along the line of access.

#### 10.1.5.5 SERVO TRACK NUMBERING (see figure 16)

The servo tracks are consecutively numbered starting at the outermost track :

$$-12,5; -11,5; \dots -0,5; +0,5; \dots +428,5.$$

This numbering system has been chosen because the centre-lines of the servo tracks +0,5 to 409,5 shall be spaced nominally half-way between the data track centrelines of tracks 000 to 410.

#### 10.1.5.6 SERVO ZONE (see figure 16)

The servo zone shall contain 412 servo tracks alternating between plus-odd and minus-even, from servo track -0,5 to 410,5.

#### 10.1.5.7 GUARD ZONES (see figure 16)

The outer guard zone shall consist of 12 plus-odd servo tracks, from servo track -12,5 to -1,5. The inner guard zone shall consist of 18 minus-even servo tracks, from servo tracks 411,5 to 428,5. The nominal radii (see figure 13) calculated from the values given in 10.1.5.3 and 10.1.5.4 shall be :

$$R_{-13} = 163,746 \text{ mm (6.446 7 in),}$$

$$R_{-1} = 162,164 \text{ mm (6.384 4 in),}$$

$$R_{411} = 107,840 \text{ mm (4.245 7 in),}$$

$$R_{429} = 105,471 \text{ mm (4.152 4 in).}$$

#### 10.1.5.8 HEAD LOADING ZONE (see figures 13, 16)

The head loading zone shall extend from

$$R_{HL} = 169,545 \text{ mm (6.675 0 in) to}$$

$$R_{-13} = 163,746 \text{ mm (6.446 7 in).}$$

It shall be erased. AC- or DC-erase may be used.

### 10.1.6 Index

#### 10.1.6.1 DEFINITION

Index is the point which defines the beginning and the end of a track. At the instant of having detected the index pattern (see 10.1.6.2), index for each data track is under the corresponding read/write gap on its line of access.

#### 10.1.6.2 INDEX PATTERN

The index pattern is the pulse sequence :

d d d d o d o d o d o

In the servo zone "d" is a pair of dibits and "o" is an omitted pair of dibits (see figure 17).

In the guard zone "d" is a single dibit and "o" is a single omitted dibit.

### 10.1.6.3 INDEX GEOMETRY

The index pattern (see 10.1.6.2) shall be recorded on all servo tracks from  $-12,5$  to  $428,5$ . All corresponding dibits shall coincide in the X-direction on the line of access (see figure 13).

## 10.2 Measurement conditions

### 10.2.1 Rotational frequency

The rotational frequency shall be  $3\,600 \pm 72 \text{ min}^{-1}$ . For the timing measurements (see 10.3.1) a rotational frequency of  $3\,600 \pm 36 \text{ min}^{-1}$  is required.

### 10.2.2 Environmental conditions

Before measurements commence, the disk pack shall be conditioned for 24 h in the same environment as that in which the test equipment is operating and shall be run on the drive used for measurement for at least 15 min.

The testing shall be conducted under the following conditions:

input air flow :  $6 \pm 1 \text{ m}^3/\text{min}$  ( $210 \pm 35 \text{ ft}^3/\text{min}$ )

air cleanliness : class 100 (see annex A)

relative humidity : 40 to 60 %.

The pack input air temperature shall be  $20 \pm 3 \text{ }^\circ\text{C}$  ( $68 \pm 5 \text{ }^\circ\text{F}$ ). For the measurement of servo track locations, however, the air temperature (measured between disk surfaces 9 and 10, see figure 7) shall be  $20 \pm 0,25 \text{ }^\circ\text{C}$  ( $68 \pm 0,5 \text{ }^\circ\text{F}$ ).

### 10.2.3 Requirements for the measurement spindle

The following measurements shall be taken with the disk pack measurement drive spindle revolving at  $3\,600 \pm 36 \text{ min}^{-1}$ . The measurements taken in 10.2.3.3 and 10.2.3.4 are made with a high frequency cutoff defined by the flat response/high frequency asymptote intercept of 2 200 Hz and a high frequency fall-off of 18 dB per octave.

#### 10.2.3.1 RADIAL RUNOUT

The total indicated radial runout measured where the spindle contacts the hub flexure shall not exceed  $0,635 \text{ }\mu\text{m}$  ( $25 \text{ }\mu\text{in}$ ).

#### 10.2.3.2 AXIAL RUNOUT

The total indicated axial runout shall not exceed  $1,27 \text{ }\mu\text{m}$  ( $50 \text{ }\mu\text{in}$ ).

#### 10.2.3.3 ACCELERATION OF RADIAL RUNOUT

The acceleration of radial runout shall not exceed

$$\pm 12,7 \text{ m/s}^2 (\pm 500 \text{ in/s}^2).$$

#### 10.2.3.4 ACCELERATION OF AXIAL RUNOUT

The acceleration of axial runout shall not exceed

$$\pm 12,7 \text{ m/s}^2 (\pm 500 \text{ in/s}^2).$$

#### 10.2.4 Read channel for servo testing

The electrical termination of the servo test head shall be  $480 \pm 24 \text{ }\Omega$  in parallel with  $90 \pm 5 \text{ pF}$ , including the pre-amplifier input impedance and all other stray and external impedances.

The read channel shall have a frequency response flat within  $\pm 3 \text{ dB}$  and a phase shift within  $\pm 7,5^\circ$  from 250 kHz to 6 000 kHz.

The servo AGC-amplifier shall produce an output voltage constant to within  $\pm 1 \%$  for input voltages from  $V_{\text{IN, min}} = 0,3 \text{ mV}$  to  $V_{\text{IN, max}} = 10,0 \text{ mV}$  (see figure 9). The gain to achieve the AGC reference level  $V_{\text{SAGC}}$  shall be based upon the average of the preceding 250 two-byte intervals.

#### 10.2.5 Servo track average amplitude $V_{\text{STA}}$

The servo track average amplitude  $V_{\text{STA}}$  is the average of the peak-to-peak values of the signals over one revolution of the disk measured at the output of the servo test head when electrically loaded as in 10.2.4.

## 10.3 Standard reference servo surface

### 10.3.1 Characteristics

The standard reference servo surface shall be characterized at the innermost and outermost servo tracking positions as well as at the inner and outer guard zones.

When recorded with the servo pattern shown in figures 14 and 18, using a servo test head, the  $V_{\text{STA}}$  shall be

3,3 mV at track 000,

2,1 mV at track 410,

6,6 mV at track -006 (outer guard zone),

4,2 mV at track 416 (inner guard zone).

The time interval between the 50 %  $V_{\text{SAGC}}$  levels of the two pulses of one dibit ( $T_1$  to  $T_2$  and  $T_3$  to  $T_0$  in figure 18) shall be 330 ns.

### 10.3.2 Secondary standard reference servo surface

This is a surface whose output is related to the standard reference servo surface via a calibration factor  $C_{\text{SD}}$ .

The calibration factor  $C_{\text{SD}}$  is defined as

$$C_{\text{SD}} = \frac{\text{Standard reference servo surface output}}{\text{Secondary standard reference servo surface output}}$$



To qualify as a secondary standard reference servo surface,

- a) the calibration factor  $C_{SD}$  for such disks shall satisfy  $0,90 \leq C_{SD} \leq 1,10$  at the measured tracks;
- b) the dibit pulse width ( $T_1$  to  $T_2$  and  $T_3$  to  $T_0$  in figure 18) shall be  $330 \pm 20$  ns.

## 10.4 Servo test head

### 10.4.1 Description

Disk measurements shall be taken with a suitable test head<sup>1)</sup>. The test head shall be calibrated to the standard reference servo surface.

### 10.4.2 Gap width

The width of the read gap measured optically shall be

$$130 \pm 2,5 \mu\text{m} (0,005 1 \pm 0,000 1 \text{ in}).$$

### 10.4.3 Gap length

The test head ferrite core shall have a gap length of

$$2,54 \pm 0,63 \mu\text{m} (100 \pm 25 \mu\text{in}).$$

### 10.4.4 Offset angle

The angle between the read gap and the line of access shall be  $0^\circ \pm 30'$ .

### 10.4.5 Flying height

When flying over track 410, the test head shall have a flying height at the gap of

$$1,14 \pm 0,05 \mu\text{m} (45 \pm 2 \mu\text{in}).$$

### 10.4.6 Inductance

The total head inductance shall be  $9,5 \pm 0,02 \mu\text{H}$  measured in air at 1 MHz.

### 10.4.7 Resonant frequency

As measured at the head cable connector, the resonant frequency of the head shall be  $12,5 \pm 0,5$  MHz.

### 10.4.8 Calibration factor

The calibration factor  $C_{SH}$  shall satisfy

$$0,90 \leq C_{SH} \leq 1,10.$$

$C_{SH}$  is defined by

$$C_{SH} = \frac{\text{Standard reference servo surface output}}{\text{Servo test head output}}$$

when measured on a standard reference servo surface, or by

$$C_{SH} = \frac{\text{Standard reference servo surface output}}{(\text{Servo test head output}) \times C_{SD}}$$

when measured on a secondary standard reference servo surface.

### 10.4.9 Dibit pulse width

The time interval between the 50 %  $V_{SAGC}$  levels (see 10.2.4) of the two pulses of one dibit ( $T_1$  to  $T_2$  and  $T_3$  to  $T_0$  in figure 18) shall be  $330 \pm 40$  ns when measured on a standard reference servo surface.

## 10.5 Servo surface signal requirements

### 10.5.1 Servo signal timing

Figure 18 shows the servo signal with the servo head in the servo tracking centreline position. All timing measurements shall be made at 50 %  $V_{SAGC}$  (see 10.2.4).

#### 10.5.1.1 REQUIREMENTS FOR TIME INTERVALS

The time of each two-byte interval shall be :

$$\text{time interval } T_1 \text{ to next } T_1 = 2\,480 \pm 80 \text{ ns.}$$

The time of each byte interval shall be :

$$\text{time interval } T_1 \text{ to } T_3 = 1\,240 \pm 80 \text{ ns}$$

and

$$\text{time interval } T_3 \text{ to } T_1 = 1\,240 \pm 80 \text{ ns.}$$

The time between the two pulses of one dibit shall be :

$$\text{time interval } T_1 \text{ to } T_2 = 330 \pm 80 \text{ ns}$$

and

$$\text{time interval } T_3 \text{ to } T_0 = 330 \pm 80 \text{ ns.}$$

#### 10.5.1.2 CUMULATIVE TIMING ERROR

To ensure reliable operation of the servo track phase locked oscillator it is necessary to limit sudden changes in the positions of the  $T_1$  and  $T_3$  edges.

Either of the two following criteria may be agreed between the interchange parties :

- a) With the exception of the allowable missing dibits, every  $T_1$  and  $T_3$  edge shall be within  $\pm 40$  ns of its theoretical position. The theoretical position is that location where each and every timing edge is equally spaced with respect to the preceding and following edge. (This requirement is directed at limiting any frequency modulation discrepancies of the servo data.)

1) Information on suitable test heads may be obtained from the Secretariat of ISO/TC 97, or from the ISO Central Secretariat.

b) Eight consecutive dibits shall be such that the algebraic sum of the timing differences between their actual positions ( $T_1$ ,  $T_3$ ) and their predicted positions does not exceed 150 ns. The predicted positions shall be based on the average of 100 intervals immediately preceding the eight dibits being examined.

### 10.5.1.3 GUARD ZONE TIMING

The dibits on two adjacent servo tracks within the guard zones shall coincide with each other within 150 ns.

## 10.5.2 Servo signal amplitude

### 10.5.2.1 AVERAGE AMPLITUDE IN SERVO ZONES

The maximum  $V_{STA}$  corrected by  $C_{SH}$  measured at the servo test head shall be 4,6 mV at track 000, and 3,0 mV at track 410.

The corresponding minimum amplitude shall be 2,0 mV at track 000 and 1,2 mV at track 410.

### 10.5.2.2 AVERAGE AMPLITUDE IN GUARD ZONES

The  $V_{STA}$  corrected by  $C_{SH}$  measured at the servo test head shall be between 2,4 mV and 6,0 mV in the inner guard zone and between 4,0 mV and 9,2 mV in the outer guard zone.

However, these limits may be violated for periods up to 25  $\mu$ s. Such periods must be separated by not less than 1 ms.

### 10.5.2.3 LEADING PULSE AMPLITUDE

The amplitude of the leading pulses of the dibits in the servo zone shall not exceed 125 % of  $V_{SAGC}$ . The amplitudes shall be measured after the servo AGC-amplifier.

### 10.5.2.4 MISSING DIBITS

If the leading pulse amplitude of a dibit in the servo zone is less than 80 % of  $V_{SAGC}$ , this dibit is considered missing. Missing dibits shall not occur

- a) in consecutive two-byte intervals;
- b) in the index pattern (see figure 17);
- c) in more than 4 non-consecutive two-byte intervals per servo tracking centreline.

## 10.5.3 Servo surface noise

### 10.5.3.1 NOISE LIMITS FOR TWO-BYTE INTERVALS

Between the positive going pulses of the dibit pattern, read in the servo tracking centreline, no positive signal shall exceed 25 % of  $V_{SAGC}$  for a time of  $t_3 = 330$  ns and  $t_4 = 930$  ns (see figure 18).

Between the negative going pulses of the dibit pattern, read in the servo tracking centreline, no negative signal shall exceed 25 % of  $V_{SAGC}$  for a time of  $t_5 = 930$  ns and  $t_6 = 330$  ns (see figure 18).

Failure of any or all of the above testing during a two-byte interval shall be considered one count of noise. On any servo tracking centreline the count shall not exceed four. In any pair of consecutive two-byte intervals the noise count shall not exceed one.

### 10.5.3.2 NOISE LIMITS FOR THE INDEX PATTERN

Between the positive going pulses of the dibits adjacent to the omitted dibits of the index pattern, no positive signal shall exceed 25 % of  $V_{SAGC}$  for a time of  $t_7 = 3\,410$  ns (see figure 19).

Between the negative going pulses of the dibits adjacent to the omitted dibits of the index pattern, no negative signal shall exceed 25 % of  $V_{SAGC}$  for a time of  $t_8 = 2\,810$  ns (see figure 19).

### 10.5.3.3 NOISE LIMITS FOR HEAD LOADING ZONE

Continuous noise shall not exceed 0,1 mV base-to-peak, measured at the servo test head. Bursts of noise exceeding the continuous noise threshold shall have a maximum duration of 100  $\mu$ s and be separated from each other by at least 2 ms.

## 10.6 Servo surface track locations

### 10.6.1 Spacing of servo tracking centrelines

The spacing between any two adjacent servo tracking centrelines (see 10.1.5.2) when measured along the line of access and averaged over one revolution at  $20 \pm 0,25$  °C ( $68 \pm 0,5$  °F) shall be

$$132,1 \pm 1,0 \mu\text{m} \quad (5\,200 \pm 40 \mu\text{in}).$$

### 10.6.2 Co-ordinates of the reference track

The co-ordinates of the centreline of data track 245 at 20 °C (68 °F) shall be :

$$X_{245} = 129,487 \pm 0,025 \text{ mm} \quad (5,097\,9 \pm 0,001 \text{ in}),$$

$$Y = 7,772 \pm 0,051 \text{ mm} \quad (0,306\,0 \pm 0,002 \text{ in}).$$

### 10.6.3 Position of data tracks 000 and 410

The distance of the centreline of data tracks 000 and 410 from that of data track 245 measured along the line of access at 20 °C (68 °F) shall be :

$$X_0 - X_{245} = 32,360 \pm 0,051 \text{ mm} \quad (1,274 \pm 0,002 \text{ in}),$$

$$X_{245} - X_{410} = 21,793 \pm 0,025 \text{ mm} \quad (0,858\,0 \pm 0,001 \text{ in}).$$

### 10.6.4 Runout of servo tracking centrelines

The runout of the servo tracking centrelines shall not exceed 7,6  $\mu$ m (300  $\mu$ in), total indicator reading.

### 10.6.5 Index pattern location

The corresponding dibits of the index patterns of all servo tracks shall pass the line of access within  $\pm 80$  ns.

SECTION FOUR : PRE-INITIALIZATION

11 DATA TRACK PRE-INITIALIZATION

11.1 General requirements

11.1.1 Data write clock

The data write clock shall be derived from the servo information prerecorded on the servo surface of the disk pack (see also clause 10), so that speed variation does not cause variation in bit recording density. The nominal bit period shall be 155 ns, which is 0,125 of the nominal byte interval (see 10.5.1.1).

11.1.2 Mode of recording

The mode of recording shall be modified frequency modulation (MFM) for which the conditions are : a flux transition shall be written at the centre of each bit cell containing a ONE and at each cell boundary between consecutive bit cells containing ZEROS.

11.1.3 Index

See 10.1.6.

11.1.4 Byte

A byte is a group of eight bits recorded along a track numbered B8 to B1 in order of recording.

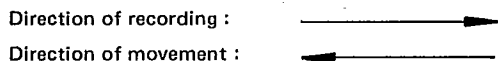
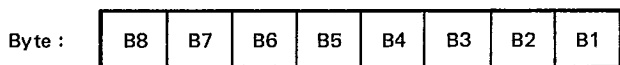

11.1.5 Hexadecimal notation

Hexadecimal notation is used hereafter to denote a number of bytes frequently used in this International Standard :

- (00) for (B8 to B1) = 0000 0000
- (01) for (B8 to B1) = 0000 0001
- (08) for (B8 to B1) = 0000 1000

- (12) for (B8 to B1) = 0001 0010
- (19) for (B8 to B1) = 0001 1001
- (FF) for (B8 to B1) = 1111 1111

11.1.6 Error correcting code (ECC)

This data checking method shall be capable of detecting single bursts of all errors up to 22 bits in length and correcting single bursts of errors up to 11 bits in length. The 7 ECC-bytes shall be hardware generated by shifting serially the relevant bits, specified later in this International Standard, through a 56 bit shift register with feedback described by the generator polynomial :

$$x^{56} + x^{55} + x^{49} + x^{45} + x^{41} + x^{39} + x^{38} + x^{37} + x^{36} + x^{31} + x^{22} + x^{19} + x^{17} + x^{16} + x^{15} + x^{14} + x^{12} + x^{11} + x^9 + x^5 + x^1 + 1$$

They shall be appended to each part of the track (i.e. home address, count and data block of record 0) written on the disk pack.

11.1.6.1 CORRECTABLE ERRORS

An error is correctable when the erroneous bits are within a part of the track subjected to ECC checking as described in 11.3 (i.e. in the home address, count and data block of record 0) and when the error extends over no more than 11 consecutive bits.

11.1.6.2 UNCORRECTABLE ERRORS

An error is uncorrectable when the erroneous bits are within a part of a track not subjected to ECC checking or when the error extends over more than 11 consecutive bits.

11.2 Track layout of an initialized data track

See below.

The different parts of this layout shall be as defined in 11.2.1 to 11.2.3.

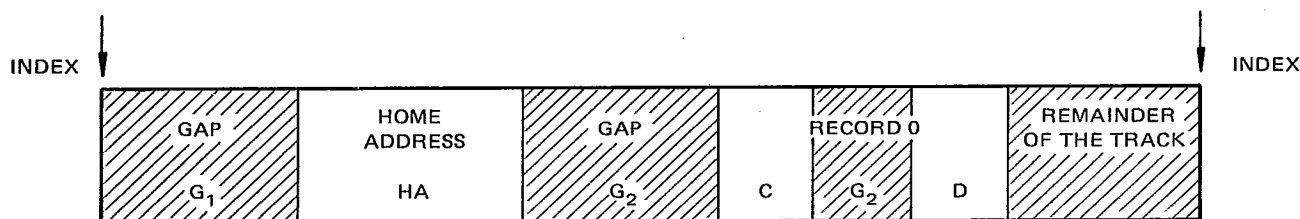

TRACK LAYOUT OF AN INITIALIZED DATA TRACK

**11.2.1 Gap ( $G_1$ )**

A gap is the space between the different fields of the track.

**11.2.2 Home address (HA)**

The home address contains information which defines the physical location and characteristics of a track.

**11.2.3 Record zero**

Record 0 is the only record on the track. On cylinders 000 to 403 it contains information to allocate alternative tracks, if any. On cylinders 404 to 410 it contains information to allocate the corresponding defective track, if any.

**11.3 Detailed description of an initialized data track****11.3.1 Index gap ( $G_1$ )**

This is a gap preceding the home address. At writing 83 (00)-bytes shall be recorded with no tolerance from index up to the start of the home address.

**11.3.2 Home address (HA)**

The home address shall comprise 24 bytes. As a result of interchange, the start of the home address is located  $83 \pm 2$  bytes from the index when reading, due to alignment tolerances of the read-write heads with regard to the servo head.

The structure of the home address shall be as shown below.

**11.3.2.1 SYNCHRONIZATION**

This field shall comprise :

- 7 (00)-bytes,
- 2 (19)-bytes.

These two (19)-bytes serve to recognize the start of the actual information.

**11.3.2.2 PHYSICAL ADDRESS (PA)**

This field shall comprise 2 bytes; it defines the physical address of the track. The significance of the bits in the bytes shall be :

- the first byte indicates the low order cylinder address, i.e. it represents the numbers 0 to 255 in binary notation;
- in the second byte :

the bit in position B8 is always ZERO;

the bit in position B7 indicates the high order cylinder address 256;

the bit in position B6 is always ZERO;

the bits in positions B5 to B1 indicate the head addresses 0 to 18 in binary notation, the bit B5 being the most significant bit.

**11.3.2.3 FLAG (F)**

This field shall comprise one single byte; it indicates defective and alternative tracks :

- the bits in position B8 to B3 are always ZERO;
- the two-bit combinations in position B2, B1 have the significance shown in the table on page 18.

SYNCHRONIZATION		PA	F	C	H	ECC	END
7 bytes	2 bytes	2 bytes	1 byte	2 bytes	2 bytes	7 bytes	1 byte
(00)	(19)						(FF)

STRUCTURE OF HOME ADDRESS

B2, B1	Cylinders	Meaning
00	000 to 403	Good original track
	404 to 410	Good unassigned alternative track
01	000 to 403	Shall not occur in these cylinders
	404 to 410	Good assigned alternative track
10	000 to 403	Defective original track, a good alternative track being assigned in one of cylinders 404 to 410
	404 to 410	Shall not occur in these cylinders
11	000 to 403	Shall not occur in these cylinders
	404 to 410	Defective track, no alternative track allocated

**11.3.2.4 CYLINDER (C)**

This field shall comprise 2 bytes which specify in binary notation the address of the cylinder. The first byte shall contain the high order cylinder address 256. The bits in position B8 to B2 shall be always ZERO. The bit in position B1 can be ZERO or ONE.

If the first byte is a (00)-byte, the second byte shall represent in binary notation a value in the range 0 to 255. If the first byte is a (01)-byte, the second byte shall represent in binary notation a value in the range 0 to 154.

**11.3.2.5 HEAD (H)**

This field shall comprise two bytes. They shall specify the address of a track within a cylinder :

- the first byte is always a (00)-byte;
- the second byte represents in binary notation a value in the range 0 to 18.

**11.3.2.6 ERROR CORRECTING CODE (ECC)**

These bytes shall be generated as defined in 11.1.6 using the bytes of HA beginning with the second (19)-byte of the synchronization field (see 11.3.2.1) and ending with the head address.

**11.3.2.7 END OF HOME ADDRESS**

The home address shall end with one (FF)-byte.

**11.3.3 Intermediate gap (G<sub>2</sub>)**

A gap G<sub>2</sub> of 39 (00)-bytes shall be recorded between the home address and the start of the first field of record 0.

**11.3.4 Record 0**

This field shall comprise three parts :

- the count of record 0,
- the gap,
- the data block of record 0.

**11.3.4.1 COUNT OF RECORD 0 (CR)**

This field shall comprise 28 bytes (see the diagram below). It contains information which defines the physical location and characteristics of record 0 or, for a defective track, the physical location of an allocated alternative track. For an alternative track, if assigned, this field contains the information defining the physical location of the defective track, to which this alternative track is assigned.

SYNCHRONIZATION		PA	F	C and H	R	KL	DL	ECC	END
7 bytes	2 bytes	2 bytes	1 byte	4 bytes	1 byte	1 byte	2 bytes	7 bytes	1 byte
(00)	(19)				(00)	(00)	(00) (08)		(FF)

**COUNT OF RECORD 0**

**11.3.4.1.1 Synchronization**

This part shall contain the 9 bytes described in 11.3.2.1.

**11.3.4.1.2 Physical address**

This part shall contain the 2 bytes described in 11.3.2.2.

**11.3.4.1.3 Flag**

This part shall contain the byte described in 11.3.2.3.

**11.3.4.1.4 Cylinder and head**

This part shall contain the 4 bytes described in 11.3.2.4 and 11.3.2.5, with two exceptions :

- on a defective track in cylinder 000 to 403, C and H contain cylinder and head number of the alternative track replacing this defective track;
- on an assigned alternative track in cylinders 404 to 410, C and H contain cylinder and head number of the defective track being replaced by this alternative track.

**11.3.4.1.5 Record (R)**

This part shall contain one single (00)-byte. It identifies records on the track.

**11.3.4.1.6 Key length (KL)**

This part shall contain one single (00)-byte.

**11.3.4.1.7 Data length (DL)**

This part shall specify the number of information bytes in the data block. It shall comprise two bytes, a (00)-byte and a (08)-byte.

**11.3.4.1.8 Error correcting code (ECC)**

This part shall comprise 7 bytes generated as defined in 11.1.6, using all the bytes of the count of record 0,

beginning with the second (19)-byte of the synchronization field (see 11.3.4.1.1) and ending with the DL bytes (see 11.3.4.1.7).

**11.3.4.1.9 End of count**

The count of record 0 shall end with one (FF)-byte.

**11.3.4.2 INTERMEDIATE GAP (G<sub>2</sub>)**

A gap of 39 (00)-bytes shall be recorded between the end of the count and the start of data block.

**11.3.4.3 DATA BLOCK OF RECORD 0**

The data block shall comprise 25 bytes as shown below.

**11.3.4.3.1 Synchronization**

This part shall comprise the 9 bytes described in 11.3.2.1.

**11.3.4.3.2 Information**

This part shall comprise 8 (00)-bytes as specified in the DL part of the count (see 11.3.4.1.7).

**11.3.4.3.3 Error correcting code (ECC)**

This part shall comprise 7 bytes generated as defined in 11.1.6, using all the bytes of the data block starting with the second (19)-byte of synchronization (see 11.3.4.3.1) and ending with the last information byte (see 11.3.4.3.2).

**11.3.4.3.4 End of the data block**

The data block shall end with one (FF)-byte.

**11.3.5 Remainder of the track**

The remainder of the track up to the index shall be filled with approximately 13 200 (00)-bytes.

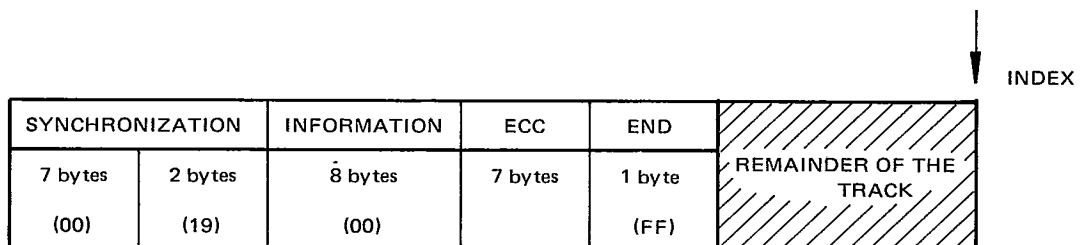

**DATA BLOCK OF RECORD 0**

11.3.6 Summary of pre-initialized data track

The above clauses can be summarized by the drawing below.

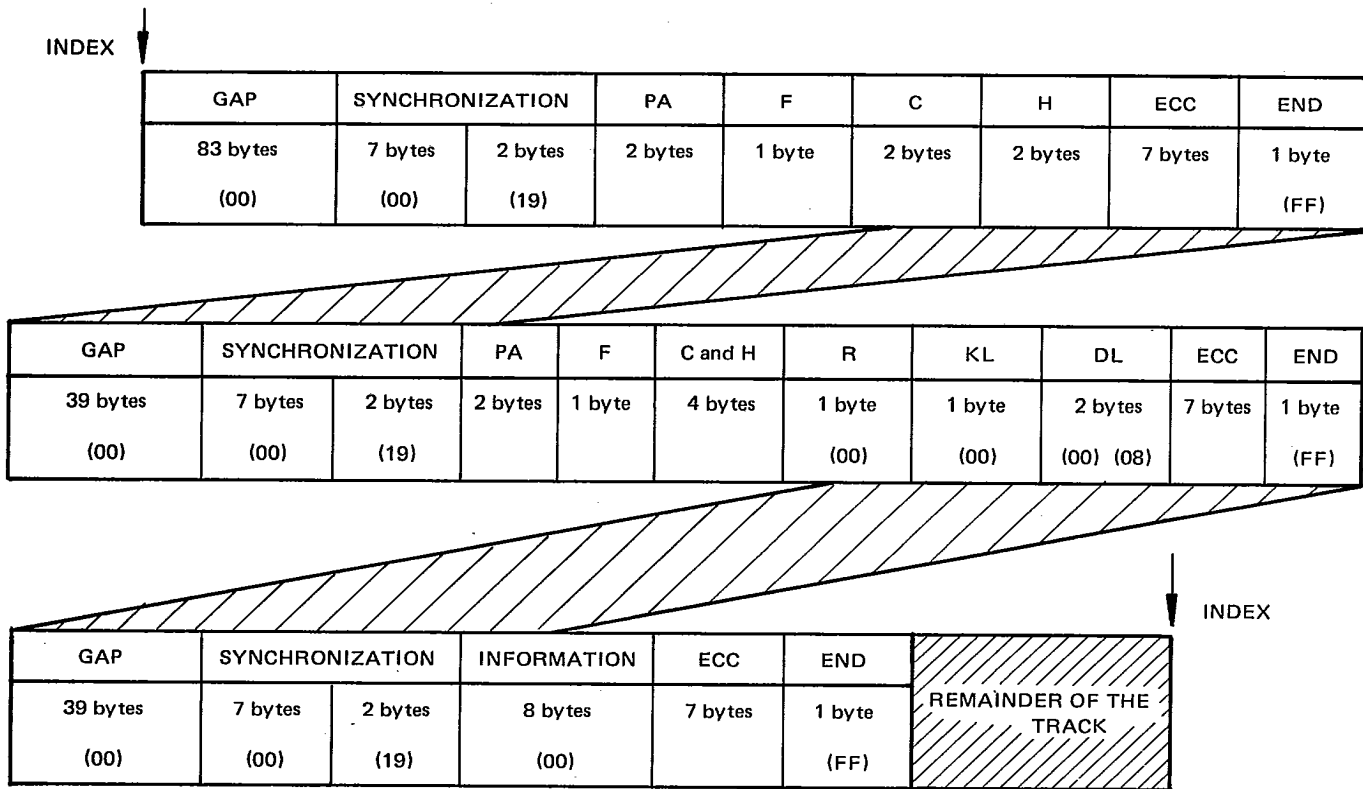

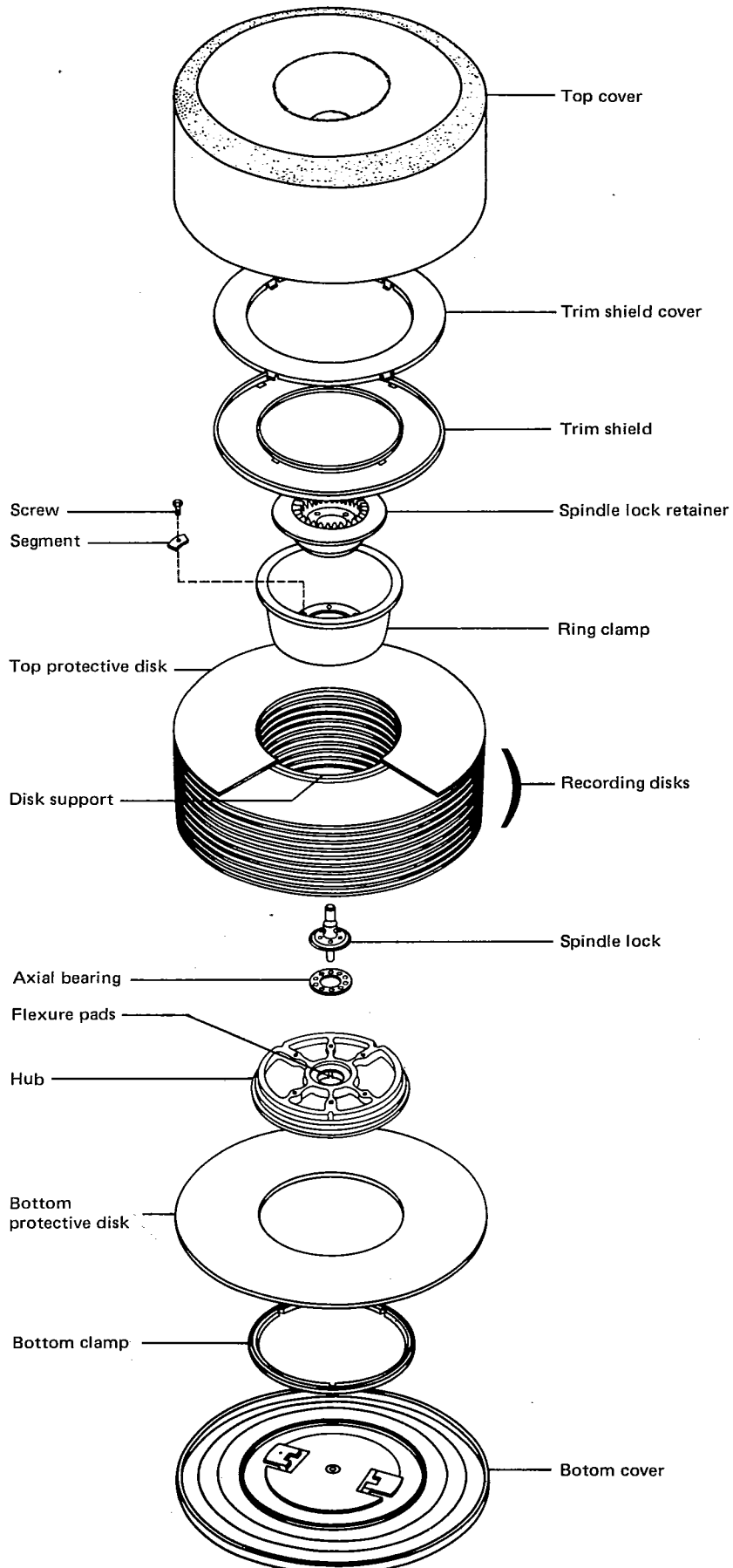

FIGURE 1 – Disk pack, exploded view



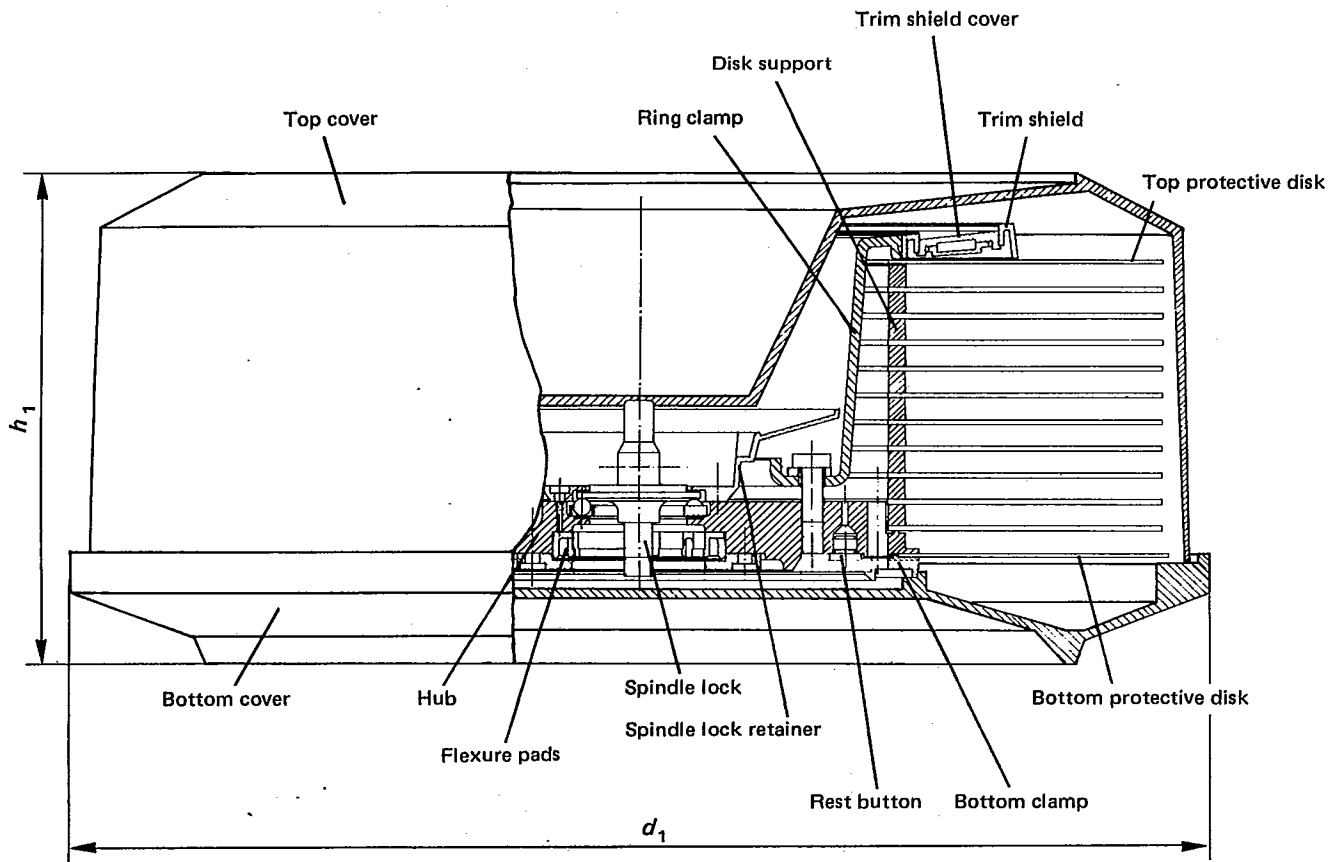

FIGURE 2 — Part sectional view of disk pack with covers

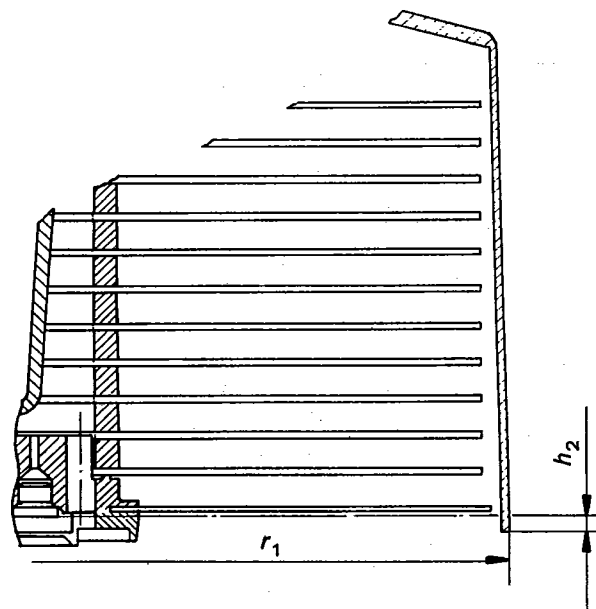

FIGURE 3 — Top cover/pack centreline relationship

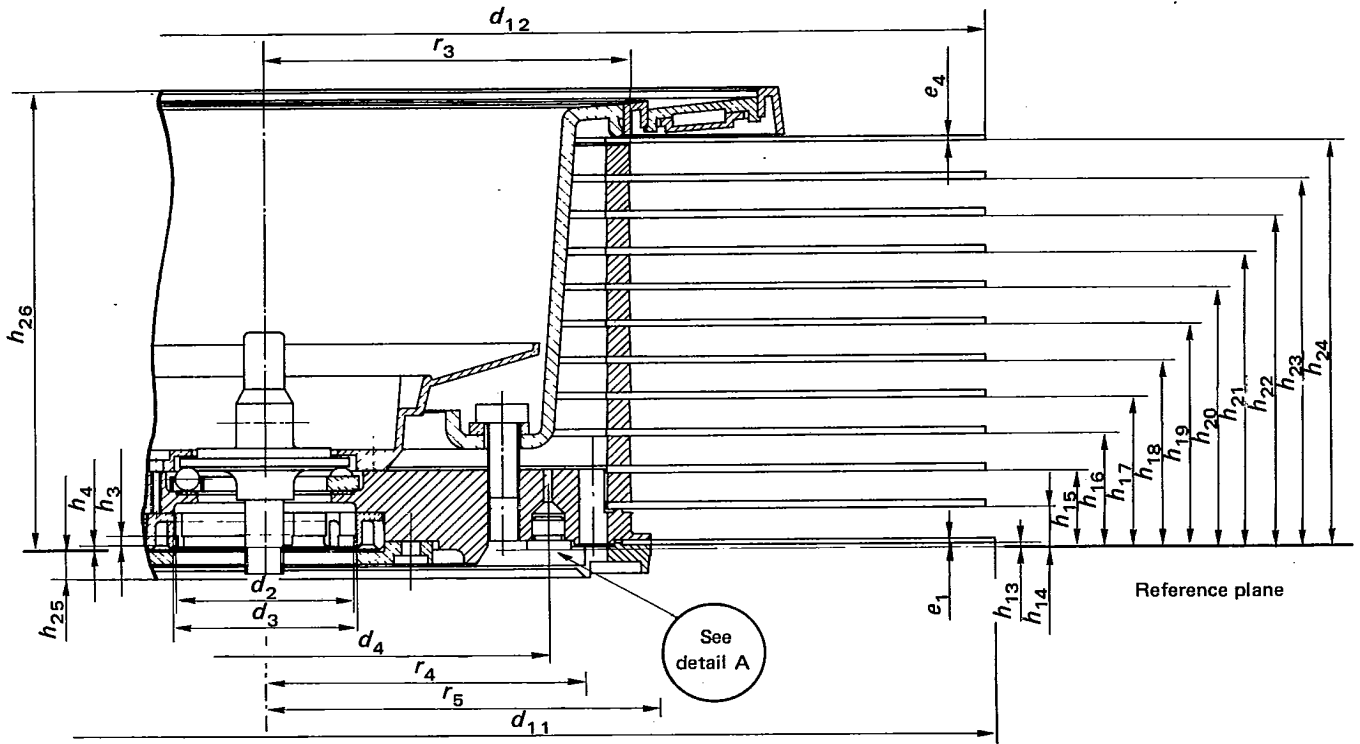

FIGURE 4 — Partial cross-section of disk pack

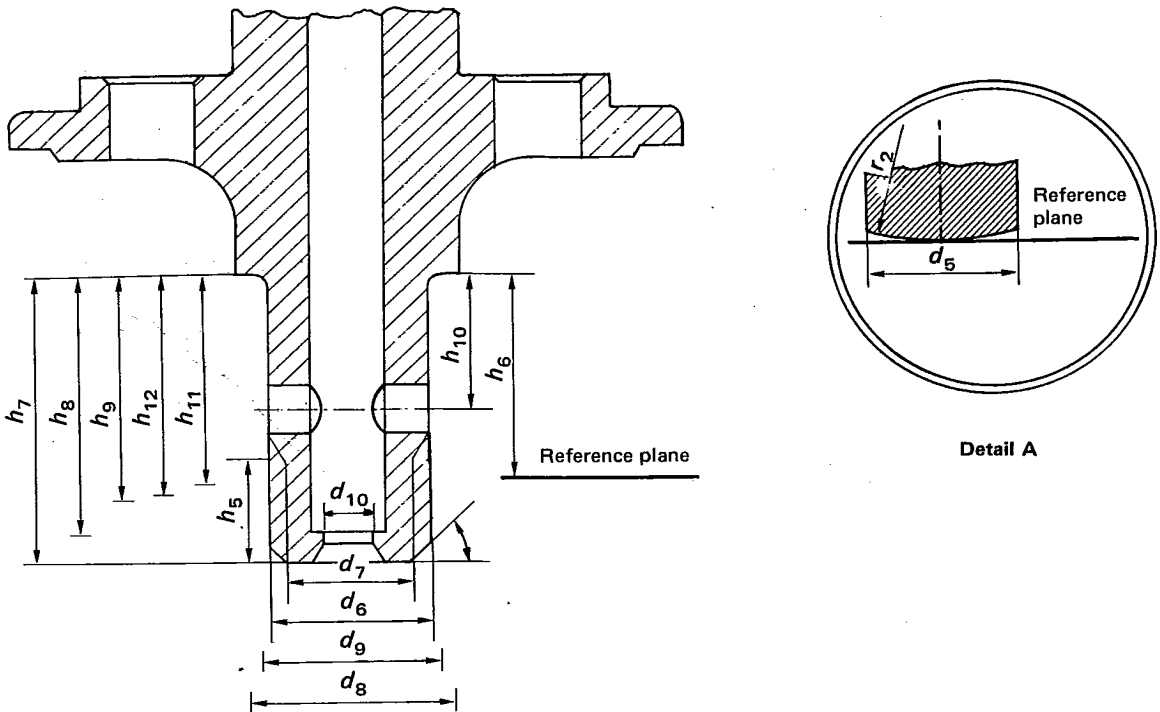

FIGURE 5 — Part detail of spindle lock

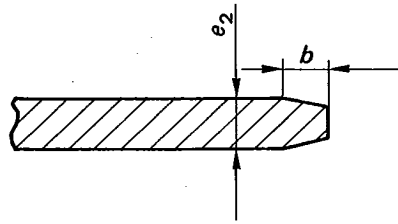

FIGURE 6 – Disk edge chamfer

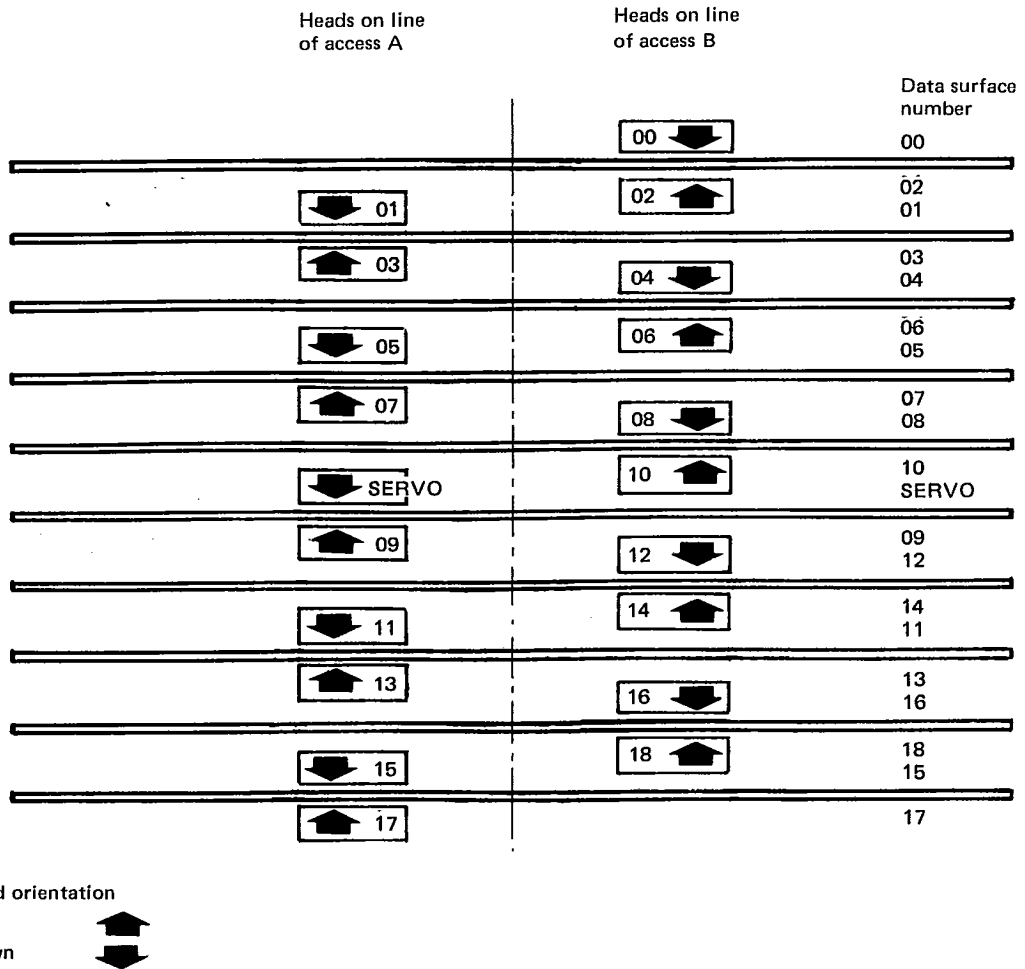

FIGURE 7 – Location of heads and surfaces

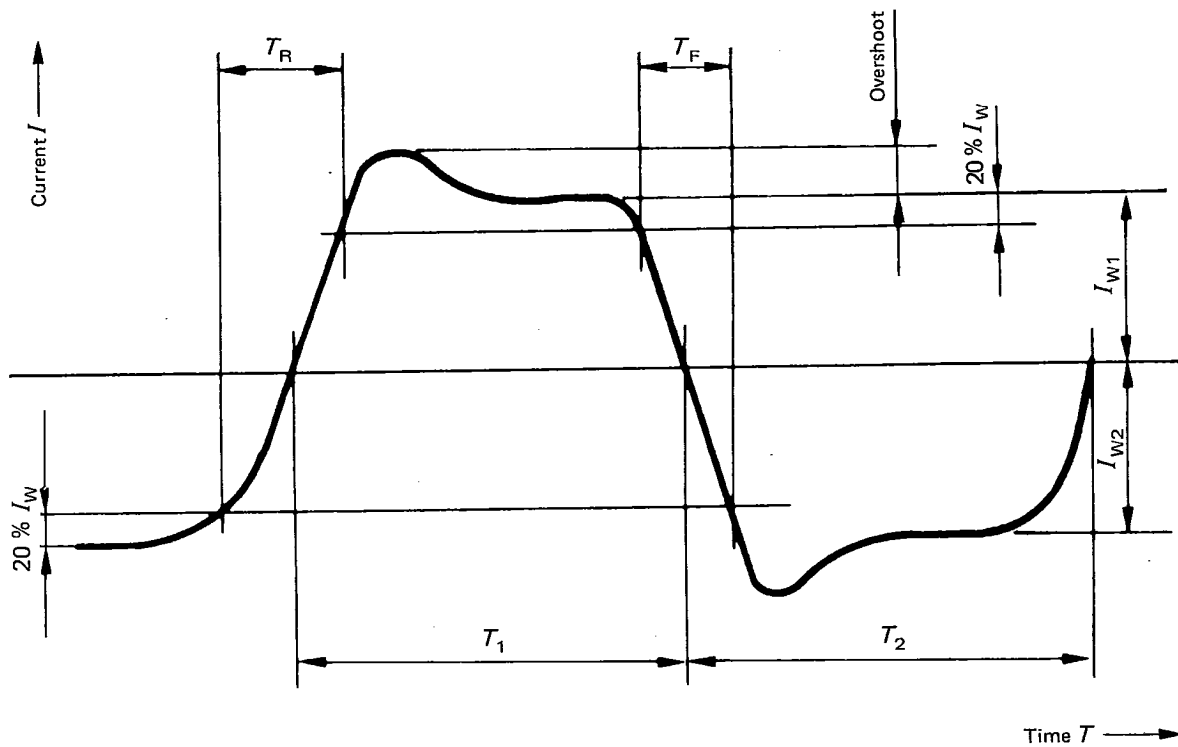

FIGURE 8 – Write current waveform

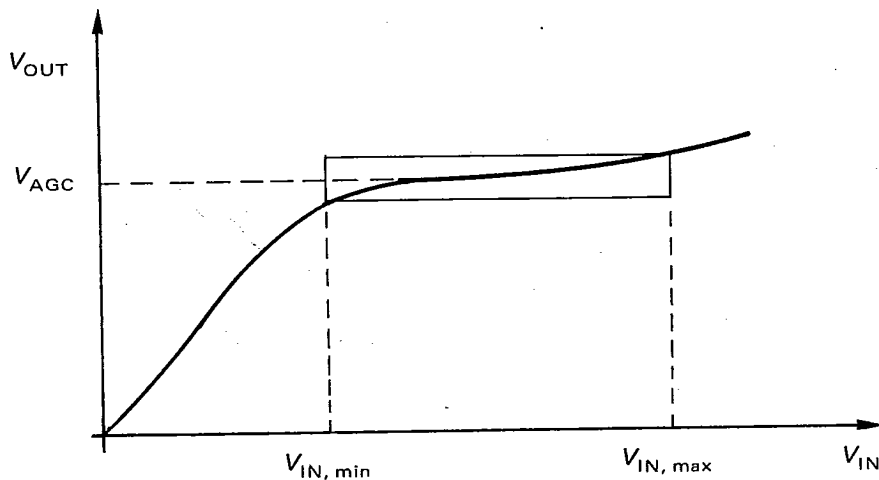

FIGURE 9 – AGC amplifier characteristics

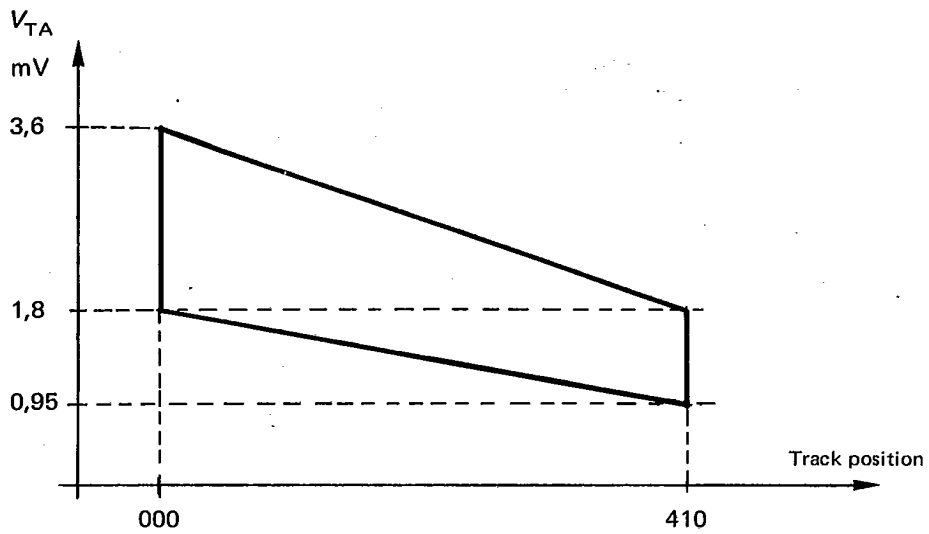

FIGURE 10 — Track average amplitude

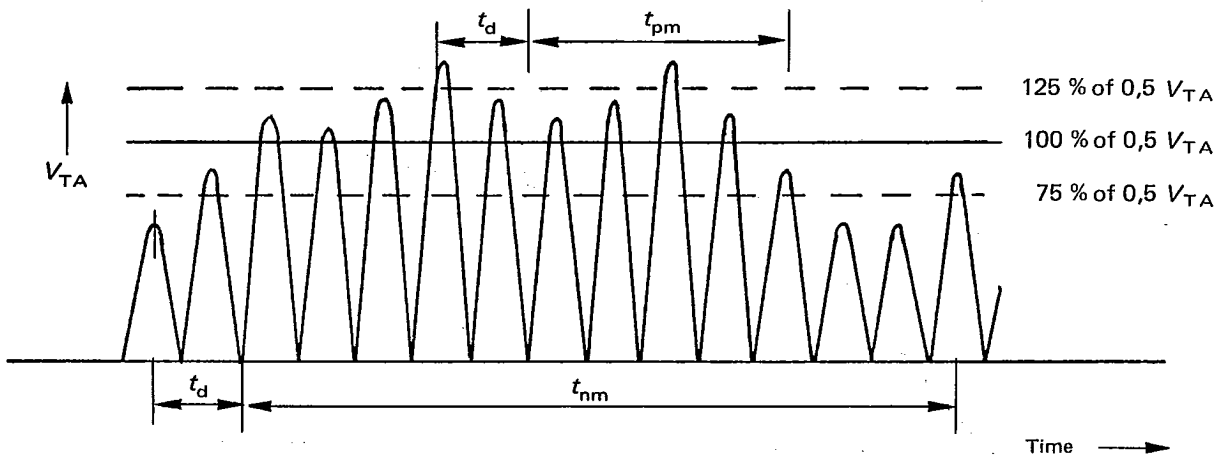

FIGURE 11 — Modulation tests

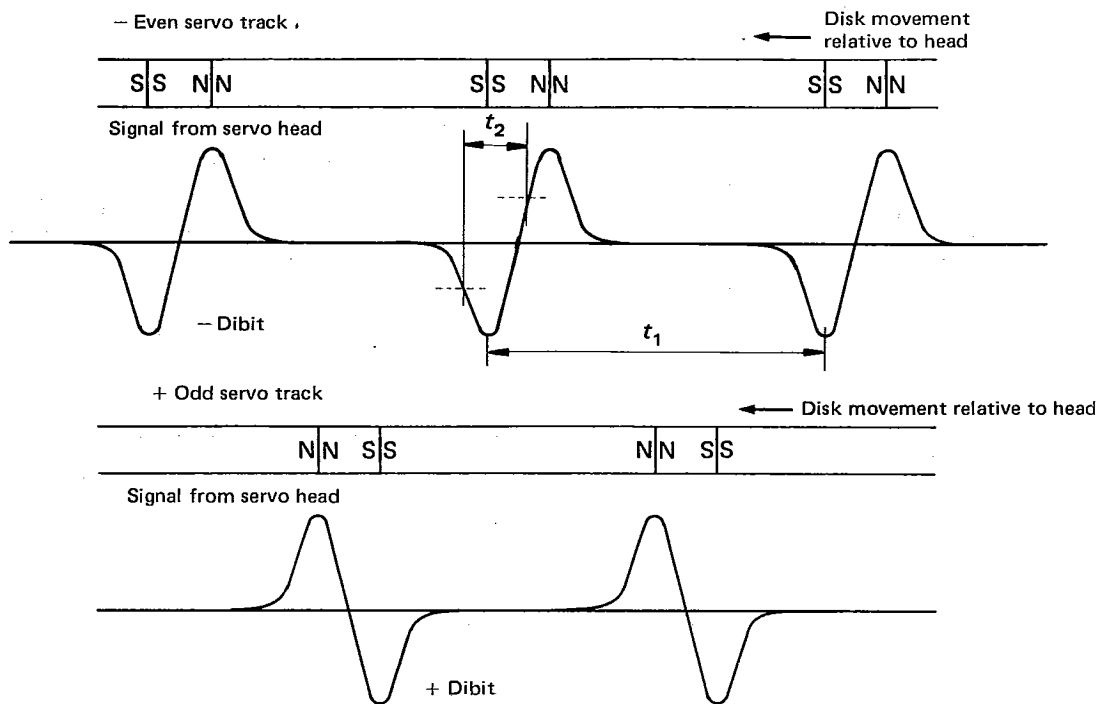

FIGURE 12 — Minus-even and plus-odd tracks

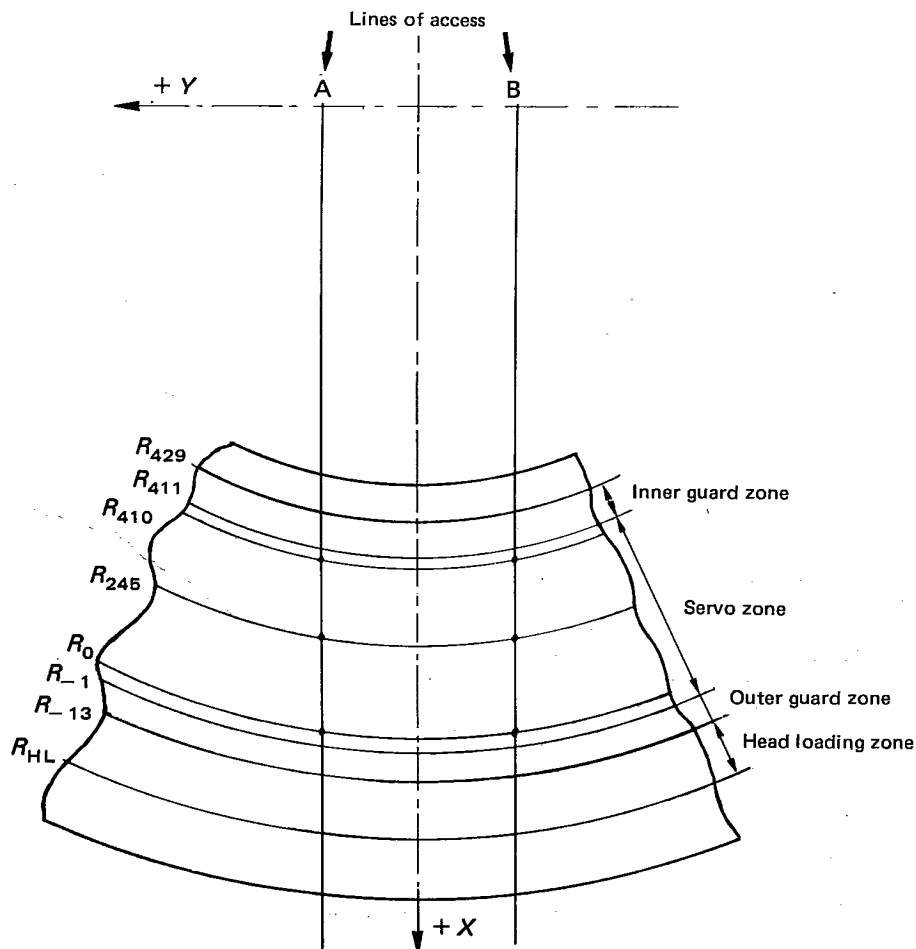

FIGURE 13 — Servo track geometry

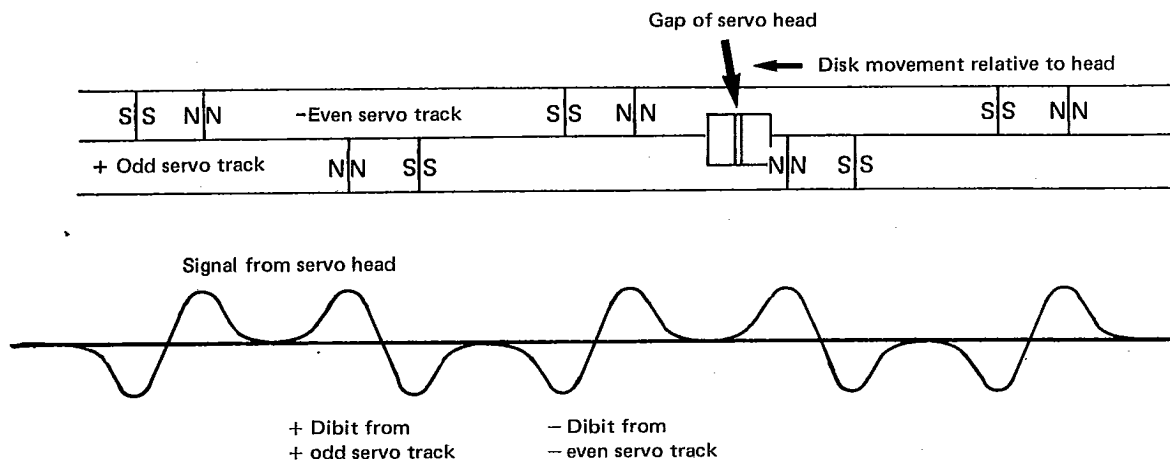

FIGURE 14 — Servo head signal at servo tracking centreline

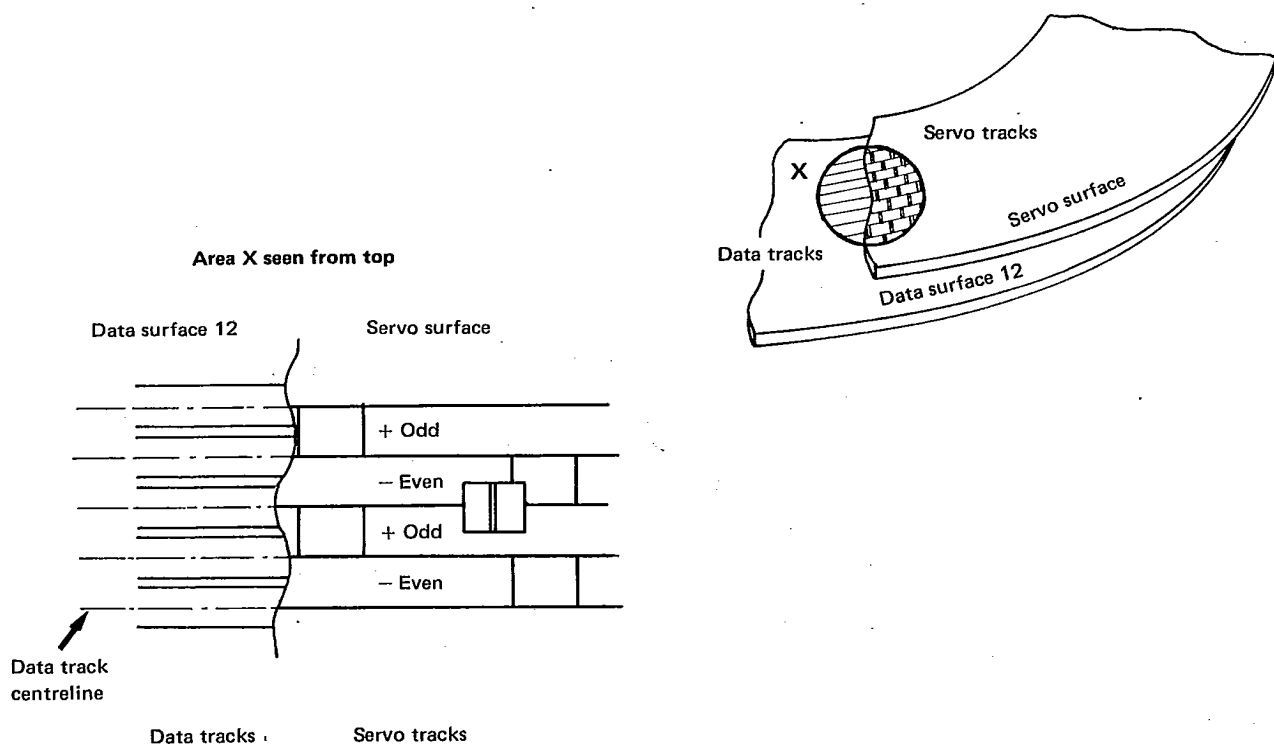

FIGURE 15 — Servo head positioning

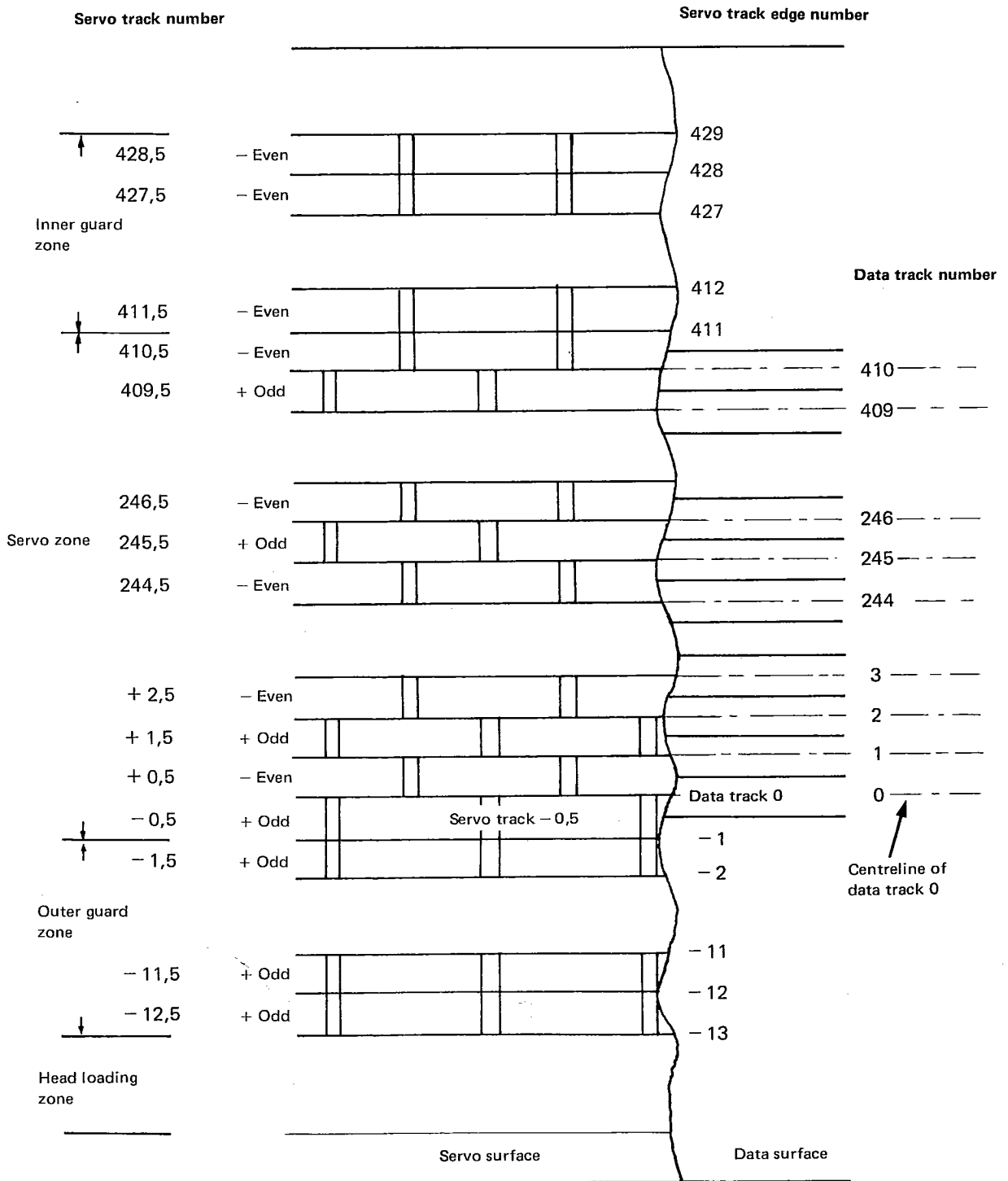

FIGURE 16 — Relationship between tracks on servo and data surfaces



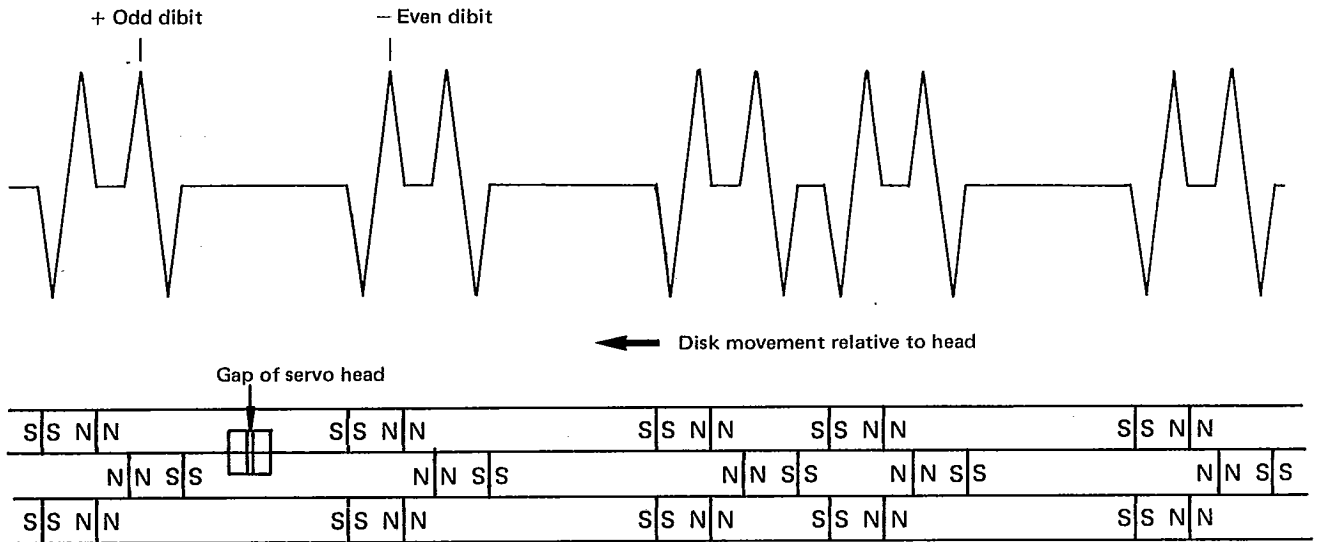

FIGURE 17 — Index pattern

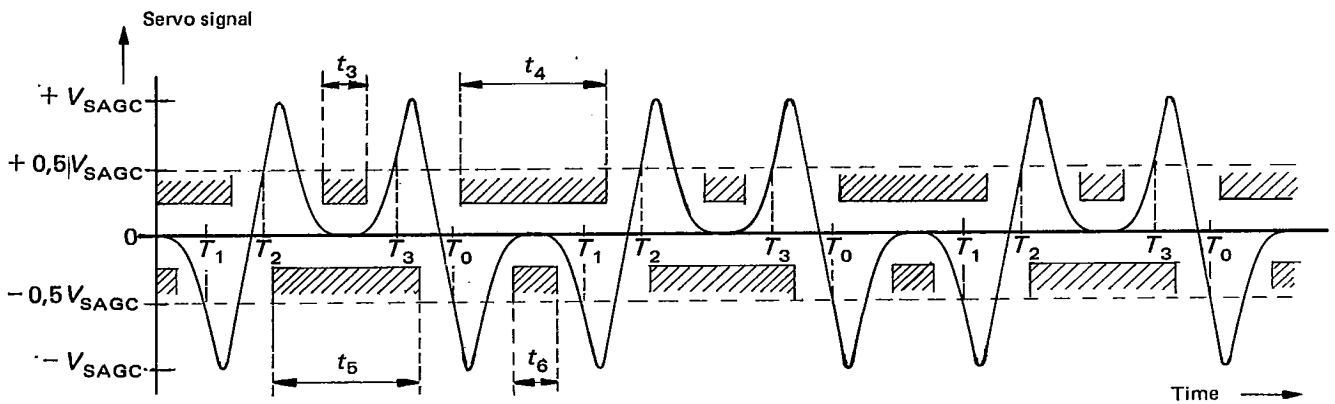

FIGURE 18 — Timing, amplitude and nose constraints for servo signal

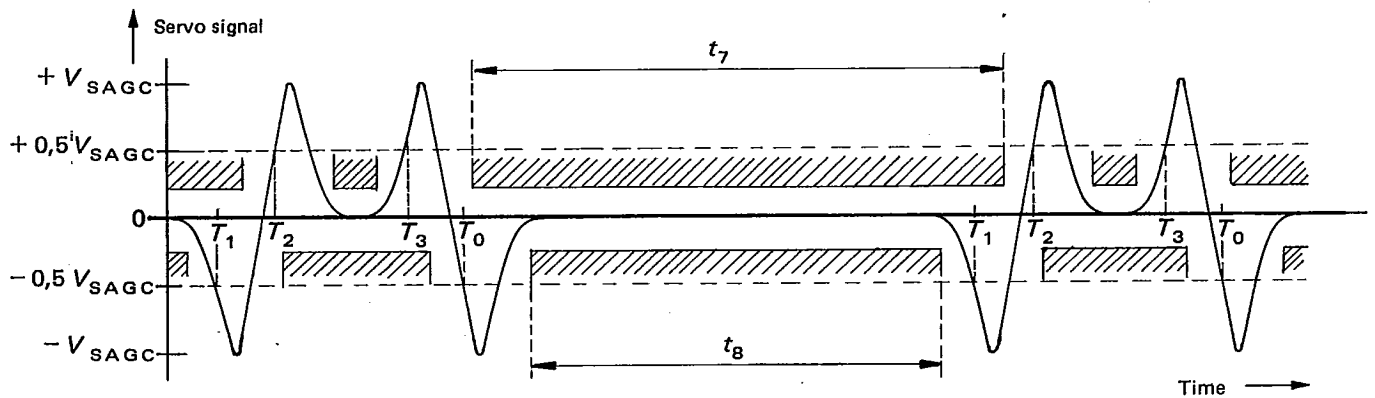

FIGURE 19 — Noise constraints for index pattern

## ANNEX A

(Not part of the standard)

AIR CLEANLINESS CLASS 100<sup>1)</sup>

Classification of air cleanliness is based on particle count with a maximum allowable number of specified minimum sized particles per unit volume and on statistical average particle size distribution.

A.1 DEFINITION<sup>2)</sup>

Class 100 is defined as follows :

Particle count not to exceed a total of 3,5 particles per litre (100 particles per cubic foot) of size 0,5  $\mu\text{m}$  and larger.

The statistical average particle size distribution is given with figure 20. Class 100 means that 3,5 particles per litre (100 particles per cubic foot) of a size 0,5  $\mu\text{m}$  are allowed, but only 0,035 particles per litre (1 particle per cubic foot) of a size 4,0  $\mu\text{m}$ .

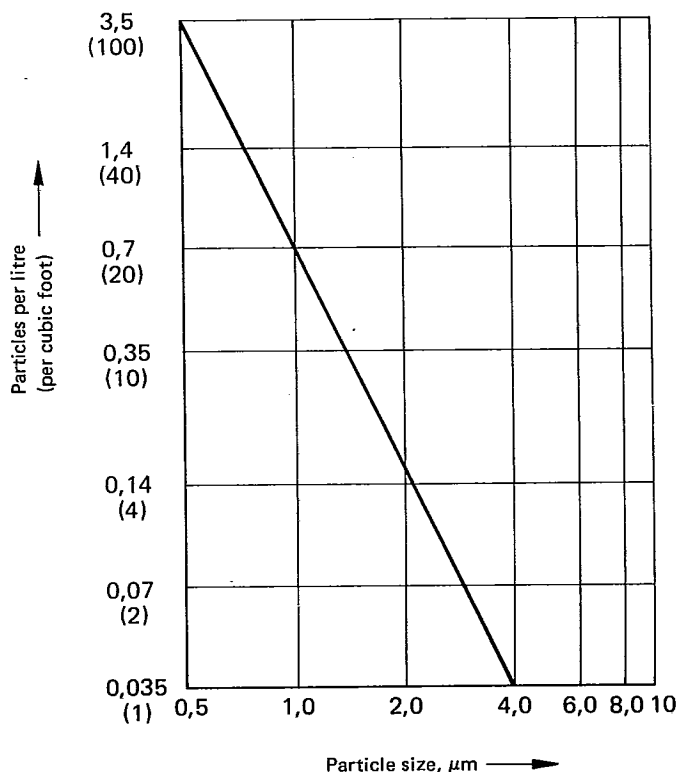

FIGURE 20 – Particle size distribution curves of air cleanliness class 100

It should be recognized that single sample distribution may deviate from this curve because of local or temporary conditions. Counts below 0,35 particles per litre are unreliable except when a large number of samplings is taken.

A.2 TEST METHOD<sup>3)</sup>

For particles in the 0,5 to 5,0  $\mu\text{m}$  size range, equipment employing light-scattering principles shall be used. The air in the controlled environment is sampled at a known flow rate. Particles contained in the sampled air are passed through an illuminated sensing zone in the optical chamber of the instrument. Light scattered by individual particles is received by a photodetector which converts the light pulses into electrical current pulses. An electronic system relates the pulse height to particle size and counts the pulses such that the number of particles in relation to particle size is registered or displayed.

1) See 5.5.1.

2) U.S.A. Federal Standard 209 B, available from the General Services Administration, Specifications Activity, Printed Materials Supply Division, Building 197, Naval Weapons Plant, Washington, DC 20407, U.S.A.

3) ASTM Standard F 50, American Society for Testing and Materials, 1916 Race Street, Philadelphia, Pa. 19103, U.S.A.

## ANNEX B

(Not part of the standard)

MEASUREMENT OF TRACK WIDTH<sup>1)</sup>

DC erase a 7-track wide band with track 400 in the centre of the band and write with  $1f$  frequency in track 400 using the head to be tested, then read back.

The read back signal amplitude in this position is called 100 %. Then move the head along its line of access over the disk in increments not greater than 0,010 mm (0.000 4 in) to the left or to the right of track 400 until the read back signal becomes zero. Determine the read back signal amplitude at each incremental move and plot the relative amplitude ( $y$  axis) versus the displacement ( $x$  axis).

See figure 21 for reading track width.

The fringing of the curve at the low level end of the curve shall be ignored for determining the track width.

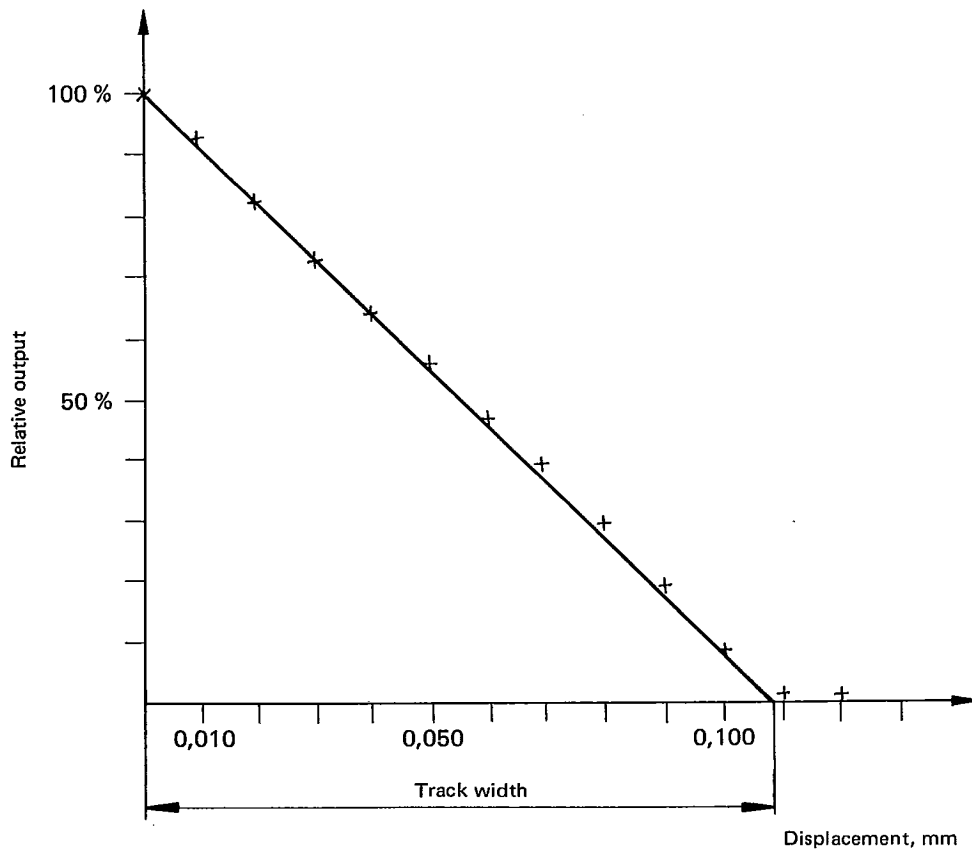

FIGURE 21 — Track width diagram

1) See 6.2.2.

## ANNEX C

(Not part of the standard)

## ECC IMPLEMENTATION

The following diagram shows the feedback connections of a 56-position shift register which may be used to generate the ECC bytes.

Prior to the operation, the shift register is set to ZERO. Input data are added (exclusive OR) to the contents of position 55 of the register to form a feedback.

This feedback is in its turn added (exclusive OR) to the contents of positions 0, 4, 8, 10, 11, 13, 14, 15, 16, 18, 21, 30, 35, 36, 37, 38, 40, 44, 48, 54.

On shifting, the outputs of the exclusive OR gates are entered respectively into positions 0, 4, 8, etc.

After the last data bit has been added, the register is shifted once more as specified above.

The register then contains the ECC bytes.

If further shifting is to take place during the writing of the ECC bytes, the control signal inhibits exclusive OR operations. To check for errors when reading, the data bits are entered into the shift register in exactly the same manner as they were during writing. After the data, the ECC bytes are also entered into the shift register as if they were data. After this operation the shift register contents will be all ZERO if the record does not contain errors.

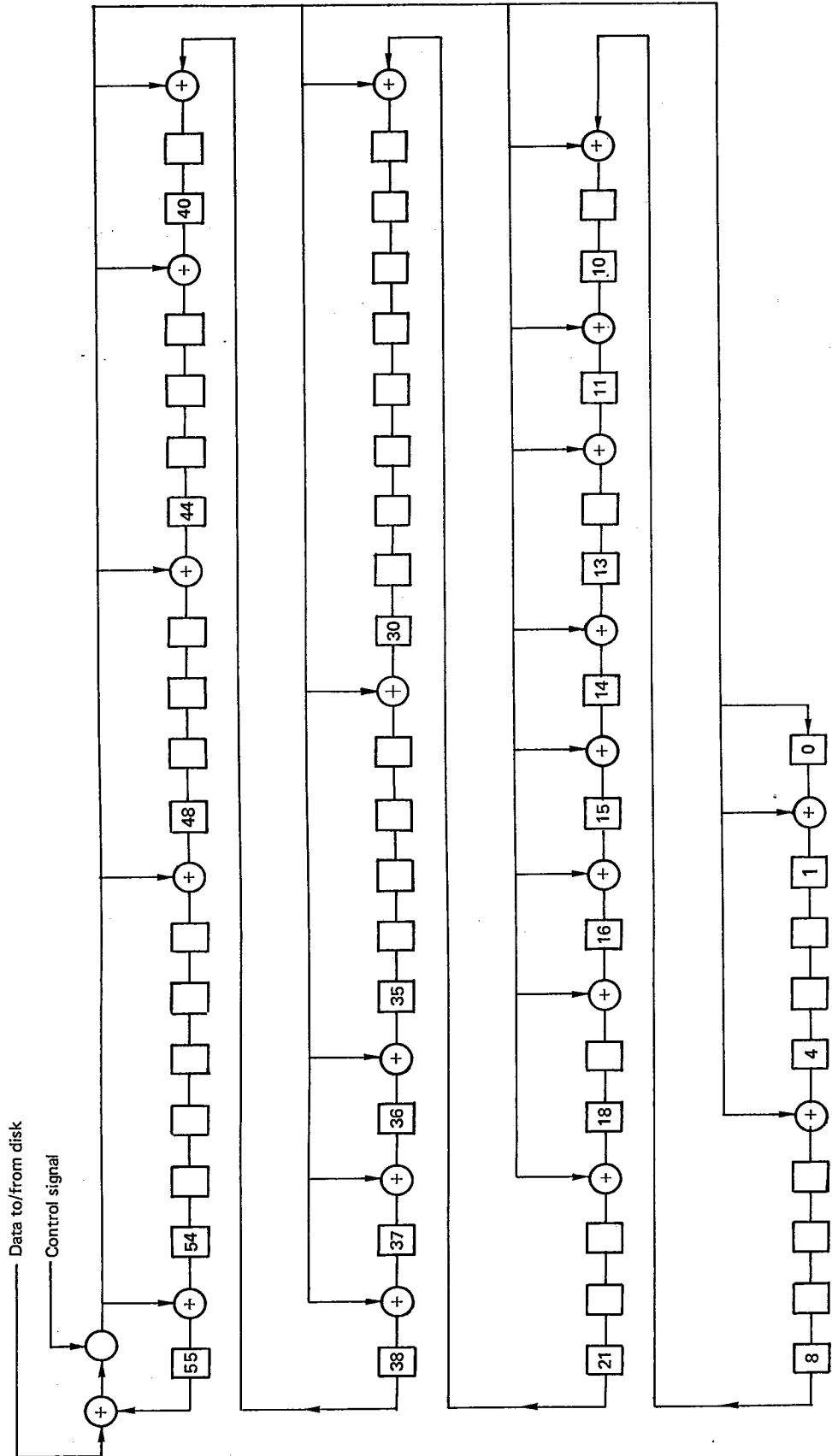

## ANNEX D

(Not part of the standard)

## GENERAL TRACK FORMAT

## D.1 SCOPE AND FIELD OF APPLICATION

This annex defines the track format of a recorded disk pack used for data interchange purposes. Only the track format for a pre-initialized disk pack, as defined in Section Four of this International Standard, is mandatory.

## D.2 REPRESENTATION OF CHARACTERS

In the information fields of the records the characters shall be represented by means of the 7-bit coded character set (ISO 646) and where required, by its 7-bit or 8-bit extensions (ISO 2022).

**D.2.1** Each 7-bit coded character is recorded in bit positions B1 to B7 of a byte; bit position B8 is recorded with value ZERO.

The relationship is as follows :

Bits of the 7-bit combination	0	b <sub>7</sub>	b <sub>6</sub>	b <sub>5</sub>	b <sub>4</sub>	b <sub>3</sub>	b <sub>2</sub>	b <sub>1</sub>
Bit position in the byte	B8	B7	B6	B5	B4	B3	B2	B1

**D.2.2** Each 8-bit coded character is recorded in bit positions B1 to B8 of a byte.

The relationship is as follows :

Bits of the 8-bit combination	b <sub>8</sub>	b <sub>7</sub>	b <sub>6</sub>	b <sub>5</sub>	b <sub>4</sub>	b <sub>3</sub>	b <sub>2</sub>	b <sub>1</sub>
Bit position in the byte	B8	B7	B6	B5	B4	B3	B2	B1

## D.3 ERROR CORRECTION

## D.3.1 Error correcting code (ECC)

This data checking method is capable of detecting single bursts of all errors up to 22 bits in length and correcting single bursts of errors up to 11 bits in length. The 7 ECC-bytes are hardware generated by shifting serially the relevant bits, specified later for each part of the track, through a 56-bit shift register described by the generator polynomial :

$$\begin{aligned}
 &x^{56} + x^{55} + x^{49} + x^{45} + x^{41} + x^{39} + x^{38} + x^{37} + x^{36} + x^{31} + \\
 &+ x^{22} + x^{19} + x^{17} + x^{16} + x^{15} + x^{14} + x^{12} + x^{11} + x^9 + x^5 + \\
 &+ x^1 + 1
 \end{aligned}$$

## D.3.2 Correctable errors

An error is correctable when the detected erroneous bits are within a part of the track subjected to ECC checking and when the error extends over at most 11 consecutive bits.

## D.3.3 Uncorrectable errors

An error is uncorrectable when the detected erroneous bits are within a part of the track not subjected to ECC checking or when the error extends over more than 22 consecutive bits.

## D.4 TRACK LAYOUT OF A RECORDED DISK PACK

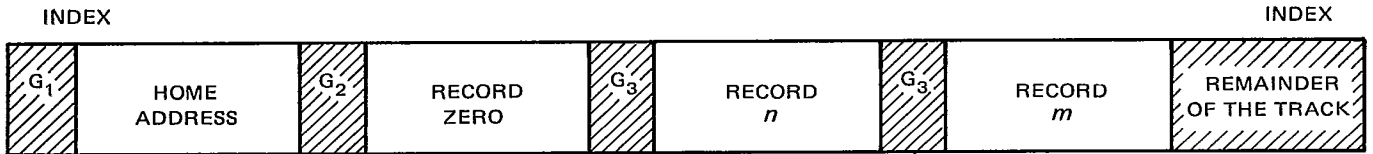

The different parts of this layout are :

### D.4.1 The pre-initialization part

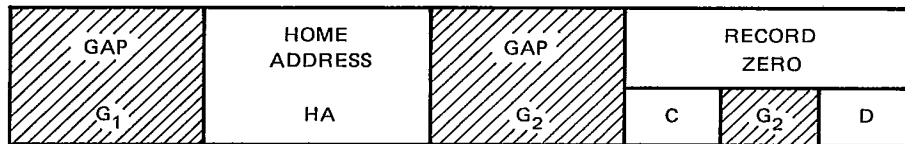

This part is described in Section Four of this International Standard. However, when using the disk pack the following fields of the pre-initialization may be modified.

#### D.4.1.1 End-byte of the home address

This field is described in 11.3.2.7 of Section Four. Instead of (FF) it may take any value. It can be used to identify the disk drive on which the home address has been modified, for example in order to flag a defective track.

#### D.4.1.2 Data length of count of record zero

This field is described in 11.3.4.1.7 of Section Four. It may take values other than (00) and (08) to accommodate other lengths of the data block.

#### D.4.1.3 End-byte of count of record zero

This field is described in 11.3.4.1.9 of Section Four. Instead of (FF) it may take any value. It can be used to identify the disk drive on which the count of record zero has been modified.

#### D.4.1.4 Information of data block of record zero

This field is described in 11.3.4.3.2 of Section Four. It shall comprise the number of bytes specified in the DL part of the count (11.3.4.1.7 of Section Four). The data shall be coded according to clause D.2 of this annex.

#### D.4.1.5 End-byte of data block of record zero

This field is described in 11.3.4.3.4 of Section Four. Instead of (FF) it may take any value. It can be used to identify the disk drive on which the data block of record zero has been modified.

### D.4.2 Gap G<sub>3</sub>

Before each record but record zero, a gap G<sub>3</sub> of 41 (00)-bytes shall be written. It shall precede the count (D.4.3.1) of each record.

These bytes may subsequently become ill-defined due to the overwriting process.

**D.4.3 Record *n***

The different parts of this layout are :

**D.4.3.1 Count of record *n***

AM	SYNCHRONIZATION		PA	F	C	H	R	KL	DL	ECC	END
3 bytes	12 bytes	2 bytes	2 bytes	1 byte	2 bytes	2 bytes	1 byte	1 byte	2 bytes	7 bytes	1 byte
	(00)	(19)									

**D.4.3.1.1 ADDRESS MARK (AM)**

This field shall comprise 3 bytes of erased track (minimum 20 bit time-intervals).

**D.4.3.1.2 SYNCHRONIZATION (SYN)**

This field shall comprise :

- 12 (00)-bytes, to allow the data decoding system to synchronize onto known data;
- 2 (19)-bytes.

**D.4.3.1.3 PHYSICAL ADDRESS (PA)**

This field shall comprise 2 bytes; it defines the physical address of the track. The significance of the bits in the bytes shall be :

- the first byte indicates the low order cylinder address, i.e. it represents the numbers 0 to 255 in binary notation;
- in the second byte :
  - the bit in position B8 is always ZERO;
  - the bit in position B7 indicates the high order cylinder address 256;
  - the bit in position B6 is always ZERO;
  - the bits in positions B5 to B1 indicate the head addresses 0 to 18 in binary notation, the bit in position B5 being the most significant bit.

**D.4.3.1.4 FLAG (F)**

This field shall comprise one single byte; it indicates the track overflow and defective and alternative tracks :

- the bits in positions B3 and B8 to B5 are always ZERO;
- the bit in position B4 shall be :
  - ONE, if the information field of the record is extended onto the data block of the record immediately following record zero of the next track of the same cylinder;
  - ZERO, in all other cases;



— the two-bit combinations in positions B2 and B1 shall have the following significance :

B2, B1	Cylinders	Meaning
00	000 to 403	Good original track
	404 to 410	Good unassigned alternative track
01	000 to 403	Shall not occur in these cylinders
	404 to 410	Good assigned alternative track

The combinations 10 and 11 shall not occur.

#### D.4.3.1.5 CYLINDER (C)

This field shall comprise 2 bytes which specify in binary notation the address of the cylinder. The first byte shall contain the high order cylinder address 256. The bits in positions B8 to B2 shall be ZERO. The bit in position B1 can be ZERO or ONE.

If the byte is a (00)-byte, the second byte represents in binary notation a value in the range 0 to 255. If the first byte is a (01)-byte, the second byte represents in binary notation a value in the range 0 to 154.

#### D.4.3.1.6 HEAD (H)

This field shall comprise two bytes; they specify the address of a track within a cylinder :

- the first byte is always a (00)-byte;
- the second byte represents in binary notation a value in the range 0 to 18.

#### D.4.3.1.7 RECORD (R)

This field shall comprise one single byte which is a binary number identifying each record on the track.

#### D.4.3.1.8 KEY LENGTH (KL)

This field shall comprise one single byte giving the length of the information field (D.4.3.3.2) of the key block (D.4.3.3).

#### D.4.3.1.9 DATA LENGTH (DL)

This field shall comprise two bytes giving the number of bytes of the information field (D.4.3.5.2) of the data block (D.4.3.5).

#### D.4.3.1.10 ERROR CORRECTING CODE (ECC)

This field comprises 7 bytes described in D.3.1, using bytes of the count of record  $n$  beginning with the second (19)-byte of the synchronization field and ending with the second DL byte.

#### D.4.3.1.11 END OF COUNT

This field shall comprise one single byte. It may be used to identify the disk drive writing the record.

#### D.4.3.2 Intermediate gap $G_2$ after the count

An intermediate gap  $G_2$  of 39 (00)-bytes shall be recorded after the end-byte of the count. It precedes the key block if this field is present. (See also D.4.3.3.) If there is no key block, it then precedes the data block.

These bytes may subsequently become ill-defined due to the overwriting process.

**D.4.3.3 Key block**

This field is present if and only if the byte in KL (D.4.3.1.8) is not a (00)-byte. A key block shall have the following layout :

SYNCHRONIZATION		INFORMATION	ECC	END
7 bytes	2 bytes	255 bytes	7 bytes	1 byte
(00)	(19)	max.		

**D.4.3.3.1 SYNCHRONIZATION**

This field shall comprise 9 bytes as described in D.4.3.1.2.

**D.4.3.3.2 INFORMATION**

This field shall comprise a number of information bytes equal to that indicated by KL (D.4.3.1.8), but at most 255 bytes. The data shall be coded according to clause D.2 of this annex.

**D.4.3.3.3 ERROR CORRECTING CODE (ECC)**

This field comprises 7 bytes as described in D.3.1 using bytes of the key block starting with the second (19)-byte of the synchronization field and ending with the last byte of the information field.

**D.4.3.3.4 END OF KEY BLOCK (END)**

This field shall comprise one single byte. It may be used to identify the disk used for writing the record.

**D.4.3.4 Intermediate gap  $G_2$  between key block and data block**

When the byte in KL (D.4.3.1.8) is not a (00)-byte, a further gap  $G_2$  of 39 (00)-bytes shall be recorded between the key block and the data block (D.4.3.5).

These bytes may subsequently become ill-defined due to the overwriting process.

**D.4.3.5 Data block**

This field shall have the following layout :

SYNCHRONIZATION		INFORMATION	ECC	END
7 bytes	2 bytes		7 bytes	1 byte
(00)	(19)			

**D.4.3.5.1 SYNCHRONIZATION**

This field shall comprise 9 bytes as described in D.4.3.1.2.

**D.4.3.5.2 INFORMATION**

This field shall comprise a number of information bytes equal to the number indicated by DL (D.4.3.1.9). The data shall be coded according to clause D.2 of this annex.

If DL comprises two (00)-bytes, then one single (00)-byte shall be written in this field. It then indicates the end of the file.

**D.4.3.5.3 ERROR CORRECTING CODE (ECC)**

This field shall comprise 7 bytes as described in D.3.1 using the bytes of the data block starting with the second (19)-byte of synchronization and ending with the last byte of the information field.

**D.4.3.5.4 END OF DATA BLOCK (END)**

This field shall comprise one single byte. It may be used to identify the disk drive used for writing the record.

**D.4.4 Subsequent record (record  $n$ )**

If — besides the pre-initialization — the track comprises more than one record (record  $n$ ) a gap  $G_3$  (D.4.2) shall be written between the end byte (D.4.3.5.4) of record  $n$  and the address mark (AM) of the count of the next record (record  $m$ ).

It should be noted that  $n$  and  $m$  need not be consecutive numbers.

**D.4.5 Remainder of the track**

When no further records are to be written, the remainder of the track shall be overwritten with (00)-bytes to the index.

**D.5 SUMMARY OF THE COMPLETE TRACK FORMAT**

The above clauses can be summarized by the following drawing :

