

---

---

**Petroleum and related products —  
Determination of the ageing behaviour of  
inhibited oils and fluids — TOST test —**

**Part 4:  
Procedure for industrial gear oils**

*Pétrole et produits connexes — Détermination du comportement au  
vieillessement des fluides et huiles inhibés — Essai TOST —*

*Partie 4: Méthode pour les huiles pour engrenages industriels*



Reference number  
ISO 4263-4:2006(E)

© ISO 2006

**PDF disclaimer**

This PDF file may contain embedded typefaces. In accordance with Adobe's licensing policy, this file may be printed or viewed but shall not be edited unless the typefaces which are embedded are licensed to and installed on the computer performing the editing. In downloading this file, parties accept therein the responsibility of not infringing Adobe's licensing policy. The ISO Central Secretariat accepts no liability in this area.

Adobe is a trademark of Adobe Systems Incorporated.

Details of the software products used to create this PDF file can be found in the General Info relative to the file; the PDF-creation parameters were optimized for printing. Every care has been taken to ensure that the file is suitable for use by ISO member bodies. In the unlikely event that a problem relating to it is found, please inform the Central Secretariat at the address given below.

© ISO 2006

All rights reserved. Unless otherwise specified, no part of this publication may be reproduced or utilized in any form or by any means, electronic or mechanical, including photocopying and microfilm, without permission in writing from either ISO at the address below or ISO's member body in the country of the requester.

ISO copyright office  
Case postale 56 • CH-1211 Geneva 20  
Tel. + 41 22 749 01 11  
Fax + 41 22 749 09 47  
E-mail [copyright@iso.org](mailto:copyright@iso.org)  
Web [www.iso.org](http://www.iso.org)

Published in Switzerland

# Contents

Page

<b>Foreword</b> .....	<b>iv</b>
<b>1 Scope</b> .....	<b>1</b>
<b>2 Normative references</b> .....	<b>1</b>
<b>3 Terms and definitions</b> .....	<b>2</b>
<b>4 Principle</b> .....	<b>2</b>
<b>5 Reagents and materials</b> .....	<b>2</b>
<b>6 Apparatus</b> .....	<b>3</b>
<b>7 Sampling</b> .....	<b>3</b>
<b>8 Preparation of apparatus — Cleaning of glassware</b> .....	<b>5</b>
<b>9 Procedure</b> .....	<b>5</b>
<b>10 Expression of results</b> .....	<b>6</b>
<b>11 Precision</b> .....	<b>6</b>
<b>12 Test report</b> .....	<b>7</b>
<b>Annex A (normative) Liquid-in-glass thermometer specifications</b> .....	<b>8</b>
<b>Annex B (normative) Method for the determination of the insoluble content (precipitation number)</b> .....	<b>9</b>
<b>Annex C (informative) Method for the determination of the sediment content by filtration</b> .....	<b>11</b>
<b>Annex D (informative) Method for the determination of the variation of the additives content</b> .....	<b>12</b>
<b>Annex E (informative) Method for the determination of the infra-red oxidation</b> .....	<b>13</b>
<b>Bibliography</b> .....	<b>15</b>

## Foreword

ISO (the International Organization for Standardization) is a worldwide federation of national standards bodies (ISO member bodies). The work of preparing International Standards is normally carried out through ISO technical committees. Each member body interested in a subject for which a technical committee has been established has the right to be represented on that committee. International organizations, governmental and non-governmental, in liaison with ISO, also take part in the work. ISO collaborates closely with the International Electrotechnical Commission (IEC) on all matters of electrotechnical standardization.

International Standards are drafted in accordance with the rules given in the ISO/IEC Directives, Part 2.

The main task of technical committees is to prepare International Standards. Draft International Standards adopted by the technical committees are circulated to the member bodies for voting. Publication as an International Standard requires approval by at least 75 % of the member bodies casting a vote.

Attention is drawn to the possibility that some of the elements of this document may be the subject of patent rights. ISO shall not be held responsible for identifying any or all such patent rights.

ISO 4263-4 was prepared by Technical Committee ISO/TC 28, *Petroleum products and lubricants*.

ISO 4263 consists of the following parts, under the general title *Petroleum and related products — Determination of the ageing behaviour of inhibited oils and fluids — TOST test*:

- *Part 1: Procedure for mineral oils*
- *Part 2: Procedure for category HFC hydraulic fluids*
- *Part 3: Anhydrous procedure for synthetic hydraulic fluids*
- *Part 4: Procedure for industrial gear oils*

# Petroleum and related products — Determination of the ageing behaviour of inhibited oils and fluids — TOST test —

## Part 4: Procedure for industrial gear oils

**WARNING** — The use of this part of ISO 4263 may involve hazardous materials, operations and equipment. This part of ISO 4263 does not purport to address all of the safety problems associated with its use. It is the responsibility of the user of this part of ISO 4263 to establish appropriate safety and health practices and determine the applicability of regulatory limitations prior to use.

### 1 Scope

This part of ISO 4263 specifies a method for the determination of the ageing behaviour of gear oils of categories CKC, CKD, CKS and CKT as defined in ISO 6743-6<sup>[5]</sup>. The ageing is accelerated by the presence of air and elevated temperatures, and the degradation of the oil is assessed by the change in kinematic viscosity at 100 °C, the insoluble content (precipitation number), and possibly the acid number increase, the sediment content by filtration, the additives content variation and the infra-red oxidation.

### 2 Normative references

The following referenced documents are indispensable for the application of this document. For dated references, only the edition cited applies. For undated references, the latest edition of the referenced document (including any amendments) applies.

ISO 2977:1997, *Petroleum products and hydrocarbon solvents — Determination of aniline point and mixed aniline point*

ISO 3104:1994, *Petroleum products — Transparent and opaque liquids — Determination of kinematic viscosity and calculation of dynamic viscosity*

ISO 3170:2004, *Petroleum liquids — Manual sampling*

ISO 3405:2000, *Petroleum products — Determination of distillation characteristics at atmospheric pressure*

ISO 3696:1987, *Water for analytical laboratory use — Specification and test methods*

ISO 3734:1997, *Petroleum products — Determination of water and sediment in residual fuel oils — Centrifuge method*

ISO 12185:1996, *Crude petroleum and petroleum products — Determination of density — Oscillating U-tube method*

### 3 Terms and definitions

For the purposes of this document, the following terms and definitions apply.

**3.1 insoluble content**  
precipitation number  
number of millilitres of precipitate formed when 10 ml of lubricating oil are mixed with 90 ml of precipitation naphtha, and centrifuged under the conditions of the test

**3.2 sediment by filtration**  
amount of insoluble matter, expressed in milligrams per 100 ml, retained on a filtration membrane of 1,2 µm pore size after filtration under vacuum

### 4 Principle

A test portion is reacted, in the absence of light, in the presence of air, and at a temperature appropriate to the type of industrial gear oil under test: 95 °C for CKC type; 121 °C for CKD type; 150 °C for CKS and CKT types. At the end of a 312 h period, the increase in kinematic viscosity at 100 °C, the insoluble content (precipitation number), the increase in acid number (if required), the sediment content by filtration, the additives depletion and the infra-red oxidation, are determined.

### 5 Reagents and materials

**5.1 Water**, unless otherwise specified, in accordance with the requirements of grade 2 as defined in ISO 3696:1987. Potable water means tap water, unless normal piped supplies are contaminated with particulate or highly soluble mineral content.

**5.2 Heptane** (C<sub>7</sub>H<sub>16</sub>), of reagent grade and of minimum purity 99,75 %.

**5.3 Acetone**, (CH<sub>3</sub>COCH<sub>3</sub>), of general purpose reagent grade (GPR).

**5.4 Air**, dried, oil-free, at constant pressure.

Supply from air cylinders or from a compressed air circuit is possible; this should be utilized via a regulation system to improve the consistency of the air flow.

#### 5.5 Cleaning solutions

##### 5.5.1 Strong oxidizing acid solution

The reference strong oxidizing cleaning solution on which precision was based, is chromosulfuric acid (see the following warning), but alternative non-chromium containing solutions, such as ammonium persulfate in concentrated sulphuric acid (8 g/l) have been found to give satisfactory cleanliness. A 10 % solution of three parts of hydrochloric acid (1 mol/l) and one part of orthophosphoric acid (concentrated GPR grade) removes iron oxide deposits.

**WARNING — Chromosulfuric acid is a health hazard. It is toxic, a recognized carcinogen as it contains Cr(VI) compounds, highly corrosive and potentially hazardous in contact with organic materials. When using chromosulfuric acid cleaning solution, eye protection and protective clothing are essential. Never pipette the cleaning solution by mouth. After use, do not pour cleaning solution down the drain, but neutralize it with great care owing to the concentrated sulfuric acid present, and dispose of it in accordance with standard procedures for toxic laboratory waste (chromium is highly dangerous to the environment).**

**Strongly oxidizing acid cleaning solutions that are chromium-free are also highly corrosive and potentially hazardous in contact with organic materials, but do not contain chromium which has special disposal problems.**

### 5.5.2 Surfactant cleaning fluid

A proprietary strong surfactant cleaning fluid is a preferred alternative to the strong oxidizing cleaning solution whenever the condition of the glassware permits this.

### 5.5.3 Laboratory detergent

The detergent shall be water soluble.

## 6 Apparatus

**6.1 Oxidation cell**, consisting of a large test tube of borosilicate glass, 600 mm in length, of 41 mm inside diameter, with a graduation mark to indicate a volume of 300 ml  $\pm$  1 ml at 20 °C, an air-delivery tube and a slotted cork stopper. The design and dimensions shall be as illustrated in Figure 1.

New corks should be used for each test.

**6.2 Heating bath**, consisting of a thermostatically controlled bath capable of maintaining the test oil portion in the oxidation cell at the specified temperature  $\pm$  0,2 °C. It shall be large enough to hold the required number of oxidation cells (6.1) immersed in the heat-transfer medium so that the bath liquid is at least 50 mm above the level of the oil sample. It shall be constructed to ensure that light is excluded from the test portions during the test. If a fluid bath is used, it shall be fitted with a suitable stirring system to provide a uniform temperature throughout the bath. If the fluid bath is fitted with a top, the total length of the oxidation cell within the bath shall be 390 mm  $\pm$  10 mm.

**6.3 Flowmeters**, capable of measuring a flow of air of 10 l/h with an accuracy of  $\pm$  0,5 l/h, one per oxidation cell is required.

### 6.4 Temperature-measurement devices

**6.4.1 Heating bath**. The temperature in liquid heating baths shall be measured by either a liquid-in-glass thermometer meeting the requirements of the specification given in Annex A, or an equivalent temperature-measurement system readable to  $\pm$  0,2 °C and calibrated to better than  $\pm$  0,2 °C.

**6.4.2 Oxidation cell**. The temperature in the oxidation cell shall be measured by either a liquid-in-glass thermometer meeting the requirements of the specification given in Annex A, or an equivalent temperature-measurement system readable to  $\pm$  0,2 °C and calibrated to better than  $\pm$  0,2 °C.

**6.5 Air-supply tube**. Flexible polyvinylchloride (PVC) tubing of approximately 6,4 mm inside diameter and 1,5 mm wall thickness, is required to deliver air to the oxidation cell.

**6.6 Air dryer**. Between the air supply and the flowmeters, the air shall pass through a drying tower packed with indicating grade anhydrous calcium sulfate or equivalent. The quantity of desiccant shall be sufficient to last for the entire test.

## 7 Sampling

Unless otherwise specified, samples shall be obtained in accordance with the procedures described in ISO 3170.

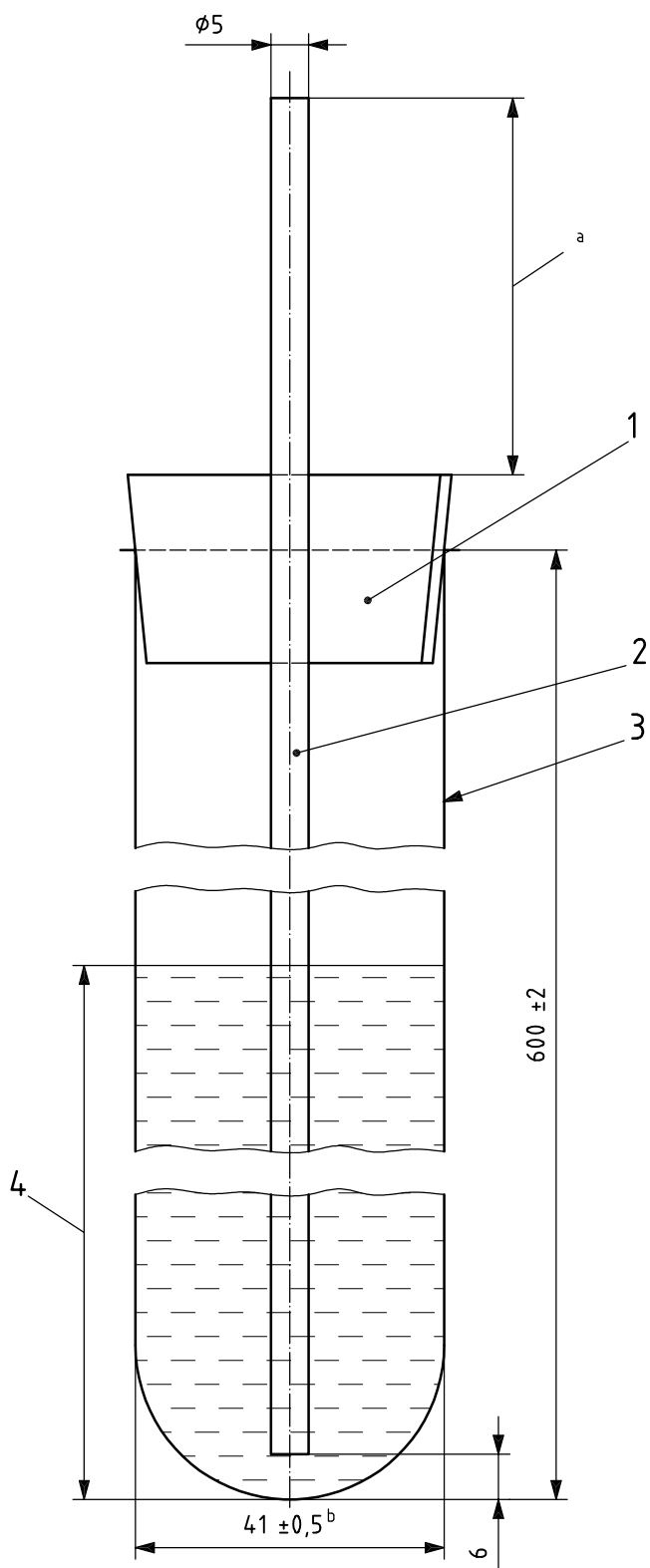

**Key**

- 1 slotted cork stopper
- 2 glass air-supply tube
- 3 borosilicate test tube
- 4 test sample, 300 ml

- a 60 to 80 mm.
- b Internal diameter.

**Figure 1 — Oxidation cell**



## 8 Preparation of apparatus — Cleaning of glassware

### 8.1 Cleaning new glassware

Wash new air-delivery tubes and oxidation cells with hot detergent solution (see 5.5.3) and rinse thoroughly with potable water (5.1). Clean the interior of the oxidation cells, and both interiors and exteriors of the air-delivery tubes by either soaking for 24 h in a 10 % solution of the surfactant cleaning fluid (5.5.2), or by washing in strong oxidizing acid solution (5.5.1). Rinse all parts thoroughly with potable water followed by water (5.1) and allow to air dry, either in an oven or by a final rinse of acetone (5.3) followed by air drying at ambient temperature.

### 8.2 Cleaning used glassware

Immediately following the termination of a test, after inspection of the tube, rinse all glassware with heptane (5.2) to remove all traces of oil. Wash with hot detergent solution (see 5.5.3) using a long-handled brush and rinse thoroughly with potable water. After all deposits have been removed, follow the cleaning procedure described in 8.1. Store all cleaned glassware in a dry, dust-free condition until required.

## 9 Procedure

**9.1** On the fresh oil, determine the viscosity at 100 °C in accordance with ISO 3104, and the insoluble content (precipitation number) (see Annex B).

It is recommended that the additive content (see Annex D), and the acid number according to either ISO 6618<sup>[3]</sup> or ISO 6619<sup>[4]</sup>, are determined; an infra-red (IR) spectrum can be recorded in the range 2 000 cm<sup>-1</sup> to 1 650 cm<sup>-1</sup>, using a cell with a calibrated thickness (see Annex E).

**9.2** Adjust the heating bath to a temperature high enough to maintain the test oil in the desired number of oxidation cells at the required temperature  $\pm 0,2$  °C. The temperature shall be chosen according to the type of fluid tested: 95 °C for the CKC-type products; 121 °C for the CKD type; and 150 °C for the CKS and CKT types.

**9.3** Connect the air-delivery tube to the air supply through the flowmeter (6.3) using flexible tubing (6.5). Adjust the flow of air to 10 l/h  $\pm 0,5$  l/h. After 30 min, check the test oil temperature and adjust the heating bath temperature if necessary. Check the air-flow rate, make the necessary adjustments, and record the time at which this is carried out. Check the temperature of the test oil once every hour for at least 3 h, making the necessary adjustments each time, until a constant test oil temperature at  $\pm 0,2$  °C is read twice in succession. Maintain the heating bath at a constant temperature, checking it daily throughout the duration of the test. The air-flow rate shall be checked at least twice a day, and adjusted whenever necessary.

**9.4** After 312 h  $\pm 2$  h, disconnect the air-delivery tube and remove the cells from the heating bath. Mix the oil thoroughly, and remove sufficient sample for the determination of:

- a) the viscosity at 100 °C, in accordance with ISO 3104;
- b) the insoluble content (precipitation number) (see Annex B).

It is recommended that the sediment content by filtration (see Annex C), the additives content of the filtrate (see Annex D), and the acid number according to either ISO 6618<sup>[3]</sup> or ISO 6619<sup>[4]</sup>, are determined on the sample. It is also recommended that the infra-red spectrum in the range from 2 000 cm<sup>-1</sup> to 1 650 cm<sup>-1</sup> is recorded, measuring the absorbance at 1 710 cm<sup>-1</sup>, for the determination of the infra-red oxidation (see Annex E).

Rinse the outside of the oxidation cell to remove the heating fluid; then pour the oil from the oxidation cell into a beaker and place the oxidation cell vertically upside down in the beaker for 72 h to allow the oil to completely drain from it. Inspect qualitatively the oxidation cell in order to rate the deposits (see Clause 10) at the oil/air interface level, on the walls and in the bottom of the cell.

**NOTE** Washing of the tube with a solvent such as heptane (5.2) can facilitate the inspection of the cell.

## 10 Expression of results

The ageing resistance of the oil shall be expressed by:

- a) the increase in kinematic viscosity at 100 °C;
- b) the increase of the precipitation number;
- c) the appearance of the tube after the test, the presence of deposits and their adhesivity, recorded as appropriate as follows:

- deposits: — nil  
— slight  
— heavy  
— very heavy
- adhesivity: — weak  
— strong

NOTE The resistance to ageing can be also assessed by

- the variation of the acid number;
- the sediment content by filtration (see Annex C);
- the variation of the additives content (see Annex D);
- the infra-red oxidation (see Annex E).

## 11 Precision

### 11.1 General

The precision has only been established for a temperature of 95 °C, and was not determined in accordance with ISO 4259<sup>[1]</sup>. For the other temperatures, the precision is not known.

### 11.2 Viscosity increase

#### 11.2.1 Repeatability, $r$

The difference between two test results obtained by the same operator with the same apparatus under constant operating conditions on identical test material would in the long run, in the normal and correct operation of the test method, exceed the values shown in Figure 2 a) in only one case in twenty.

#### 11.2.2 Reproducibility, $R$

The difference between two single and independent test results obtained by different operators working in different laboratories on identical test material would in the long run, in the normal and correct operation of the test method, exceed the values shown in Figure 2 a) in only one case in twenty.

## 11.3 Precipitation number increase

### 11.3.1 Repeatability, $r$

The difference between two test results obtained by the same operator with the same apparatus under constant operating conditions on identical test material would in the long run, in the normal and correct operation of the test method, exceed the values shown in Figure 2 b) in only one case in twenty.

### 11.3.2 Reproducibility, $R$

The difference between two single and independent test results obtained by different operators working in different laboratories on identical test material would in the long run, in the normal and correct operation of the test method, exceed the values shown in Figure 2 b) in only one case in twenty.

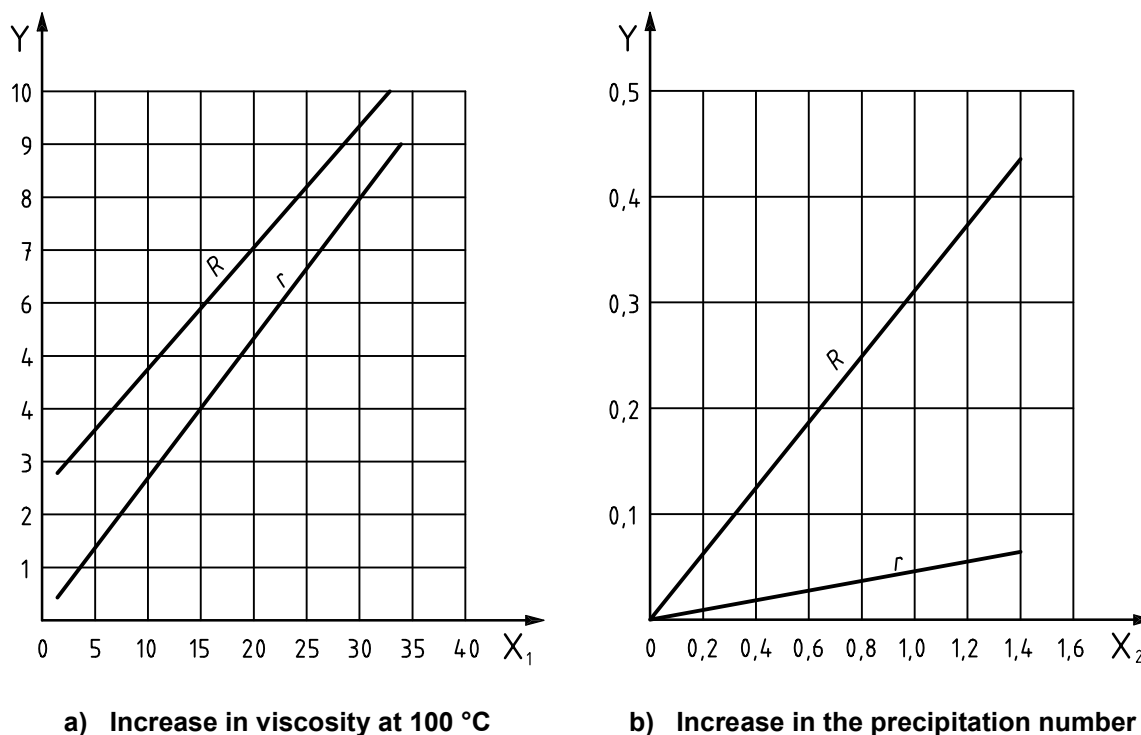

#### Key

- $X_1$  viscosity, in percent
- $X_2$  precipitation number, in millilitres
- Y maximum acceptable difference for paired results
- R reproducibility
- r repeatability

Figure 2 — Precision data

## 12 Test report

The test report shall contain at least the following information:

- a) a reference to this part of ISO 4263;
- b) the type and complete identification of the product tested;
- c) the result of the test (see Clause 10);
- d) any deviation, by agreement or otherwise, from the procedure specified;
- e) the date of the test.

## Annex A (normative)

### Liquid-in-glass thermometer specifications

The liquid-in-glass thermometers given in 6.4.1 and 6.4.2 shall meet the specifications given in Table A.1. Alternative temperature-measurement systems shall meet the performance criteria given in these specifications.

**Table A.1 — Thermometer specifications**

Thermometer		Tests at 95 °C and 121 °C	Tests at 121 °C and 150 °C
Temperature range	°C	72 to 126	98 to 152
Immersion	mm	100	100
Scale marks:			
Subdivisions	°C	0,2	0,2
Longer lines at each	°C	1	1
Numbers at each	°C	2	2
Maximum line width	mm	0,15	0,15
Scale error, maximum	°C	0,2	0,3
Total length	mm	390 to 400	390 to 400
Stem OD	mm	6,0 to 8,0	6,0 to 8,0
Bulb length	mm	15 to 20	15 to 20
Bulb OD	mm	< stem OD	< stem OD
Scale location:			
Bottom of bulb to line at	°C	72	98
Distance	mm	125 to 145	125 to 145
Scale length	mm	190 to 235	190 to 235
NOTE Thermometers ASTM 40C/IP 80C and ASTM 41C/IP 81C meet the specification of the thermometers for tests at 95 °C/121 °C and 121 °C/150 °C, respectively.			

## Annex B (normative)

### Method for the determination of the insoluble content (precipitation number)

#### B.1 Reagents and materials

**B.1.1 Precipitation naphtha**, conforming to requirements given in Table B.1.

**CAUTION — Extremely flammable, harmful if inhaled.**

Precipitation naphtha is sometimes referred to, or sold under, other names, such as petroleum naphtha, petroleum ether, ligroin, petroleum benzin and industrial naphtha. It should be confirmed that it meets the requirements of Table B.1.

**Table B.1 — Requirements for precipitation naphtha**

Test		Minimum	Maximum	Test method
Density at 15° C	kg/m <sup>3</sup>	0,692	0,702	ISO 12185
Aniline point	°C	58	60	ISO 2977
Initial boiling point	°C	not less than 50	—	ISO 3405
50 % point	°C	70	80	ISO 3405
End point	°C	—	not more than 130	ISO 3405

#### B.2 Apparatus

**B.2.1 Centrifuge tube**, conforming to the specification given in ISO 3734.

**B.2.2 Centrifuge**, meeting all the safety requirements for normal use and capable of spinning two or more filled centrifuge tubes at a speed which can be controlled to give a relative centrifugal force ( $F_{rc}$ ) between 600 and 700 at the tip of the tubes. The revolving head and trunnion cushion shall be soundly constructed to withstand the maximum centrifugal force capable of being delivered by the power source. The trunnion cups and cushions shall firmly support the tubes when the centrifuge is in motion. The centrifuge shall be enclosed by a metal shield or case strong enough to eliminate any danger if breakage occurs.

The relationship between the speed of the rotating head,  $n$ , in revolutions per minute and the relative centrifugal force, can be calculated, by means of the following equation:

$$n = 1337 \sqrt{(F_{rc}/d)}$$

where  $d$  is the diameter of swing between the tips of opposite tubes when in the rotating position, expressed in millimetres.

### B.3 Operating procedure

**B.3.1** Measure a 10 ml sample of the oil to be tested into each of two clean, dry centrifuge tubes at room temperature. Fill each tube to the 100 ml mark with the naphtha (B.1.1) and close tightly with a softened cork (not a rubber stopper). Invert the tube at least 20 times, allowing the liquid to drain thoroughly from the tapered tip of the tube each time. Place the tubes in a water bath maintained at a temperature of 32 °C to 35 °C for 5 min. Momentarily remove the corks to relieve any pressure, and invert each tube again, at least 20 times as before. The success of this method depends to a large degree upon having a thoroughly homogeneous mixture which will drain completely from the tapered tip when the tube is inverted.

**B.3.2** Balance the two centrifuge tubes or pairs of tubes with their respective trunnion cups and place them on opposite sides of the centrifuge head. Spin them for 10 min at a rate sufficient to produce a relative centrifugal force ( $F_{rc}$ ) between 600 and 700 at the tip of the whirling tubes (see B.2.2.). Repeat this operation until the volume of sediment in each tube remains constant for three consecutive readings. In general, not more than four spinnings will be required for oils having a low precipitation number.

### B.4 Calculations and test report

Read the volume of the solid sediment at the bottom of each centrifuge tube, estimating to 0,1 ml or closer if possible. If the two readings differ by not more than 0,1 ml, report the mean of the two as the "precipitation number". If the two readings differ by more than 0,1 ml, carry out two more determinations and report the average of the four determinations.

## Annex C (informative)

### Method for the determination of the sediment content by filtration

#### C.1 Reagents and materials

As described in ISO 4405<sup>[2]</sup>.

#### C.2 Apparatus

As described in ISO 4405<sup>[2]</sup>, but the cellulose ester membrane shall have an average pore diameter of 1,2 µm.

#### C.3 Operating procedure

Place 100 ml ± 1 ml of the oil taken from the oxidation cell after the test time has been completed, into the filtration apparatus, the membrane having been dried and tared (mass =  $m$ ) as indicated in ISO 4405. Start the filtration to just recover a sufficient quantity of aged oil for determination of the elements content (most commonly phosphorus, but also zinc, etc.) following the procedure given in Annex D. Once a sufficient quantity of filtrate (filtered aged oil) has been recovered, dilute the aged oil with 100 ml of heptane (5.2) and continue the filtration. After completion of the filtration, carefully rinse the membrane, then dry and weigh (mass =  $m'$ ) following the procedure described in ISO 4405<sup>[2]</sup>.

#### C.4 Calculation and report

The amount of sediment content by filtration,  $S_F$ , expressed as milligrams per 100 ml, may be calculated using the following equation:

$$S_F = m' - m$$

where

$m$  is the mass of the membrane before filtration, expressed in milligrams;

$m'$  is the mass of the membrane after filtration, expressed in milligrams.

## Annex D (informative)

### Method for the determination of the variation of the additives content

The variation of properties of the lubricants that have been submitted to ageing in accordance with this part of ISO 4263 are not always necessary linked to oxidation. It is known that extreme-pressure additives are not necessarily heat stable; they may decompose, giving rise to the formation of sludge and deposits. Some of these deposits remain on the walls of the oxidation cell, whereas others are kept in suspension in the oil. The rating of the tube gives an idea of the amount of sludge that has deposited in the tube; the evaluation of the precipitation number or the amount of sediment by filtration gives the quantity of deposits in suspension in the oil.

As the deposits mainly consist of the decomposition products of the unstable additives, the variation of the additives content between the fresh oil and the filtered oil after oxidation give an idea of the additives depletion; this depletion can be correlated with the eventual loss of extreme-pressure or anti-wear properties in service, when an oil is submitted to high thermal stresses.

In most cases, phosphorus is the main element found in additives used in extreme-pressure industrial gear oils. But other elements may also be found.

The elements content may be determined by either ASTM D 4951<sup>[7]</sup> (ICP) or by ASTM D 4927<sup>[6]</sup> (X-ray fluorescence).

The elements content loss,  $\Delta E$ , expressed as a percentage by mass after filtration may be calculated using the following equation:

$$\Delta E = [(E_2 - E_1) / E_1] \times 100$$

where

$E_1$  is the element content of the fresh oil;

$E_2$  is the element content of the filtered oil after the completion of the oxidation test (oil recovered after filtration according to the procedure described in Annex C).

$E$  can be phosphorus or zinc or any other element, depending on the additives technology used.



## Annex E (informative)

### Method for the determination of the infra-red oxidation

#### E.1 Scope

The method permits quantitative determination of the changes in the infra-red absorbance of the test oil due to oxidation.

Oil oxidation leads to the formation of oxygenated products (aldehydes, ketones, and acids) whose absorption peak in infrared is located at approximately  $1\,710\text{ cm}^{-1}$ .

#### E.2 Principle

The infrared spectra are recorded in the range  $2\,000\text{ cm}^{-1}$  to  $1\,650\text{ cm}^{-1}$  on the fresh oil and on the oil after completion of the oxidation test.

The absorbances at  $2\,000\text{ cm}^{-1}$  and at  $1\,710\text{ cm}^{-1}$  are measured on the fresh oil and on the oxidized oil and the infra-red oxidation ( $O_{IR}$ ) is calculated.

#### E.3 Apparatus

**E.3.1 Any infrared spectrometer.**

**E.3.2 Infrared cell**, with a thickness between 0,02 mm and 0,2 mm.

#### E.4 Operating procedure

Following the instructions of the infra-red spectrometer manufacturer, record the infra-red spectrum of the fresh oil and of the aged oil, in the  $2\,000\text{ cm}^{-1}$  to  $1\,650\text{ cm}^{-1}$  range, the oil being placed in a cell of known thickness (from 0,02 mm to 0,2 mm).

Determine the absorbance (or the peak height) at  $2\,000\text{ cm}^{-1}$  and at  $1\,710\text{ cm}^{-1}$ .

## E.5 Calculations and report

Calculate the infra-red oxidation,  $O_{IR}$ , using the following equation:

$$O_{IR} = \frac{1}{D} \left[ \lg \left( \frac{T_{2\,000}}{T_{1\,710}} \right)_2 - \lg \left( \frac{T_{2\,000}}{T_{1\,710}} \right)_1 \right]$$

where

$D$  is the thickness of the cell, expressed in centimetres;

$T_{2\,000}$  is the absorbance of the oil at  $2\,000\text{ cm}^{-1}$ ;

$T_{1\,710}$  is the absorbance of the oil at  $1\,710\text{ cm}^{-1}$ ;

( )<sub>1</sub> refers to the fresh oil;

( )<sub>2</sub> refers to the oil after oxidation.

## Bibliography

- [1] ISO 4259, *Petroleum products — Determination and application of precision data in relation to methods of test*
- [2] ISO 4405, *Hydraulic fluid power — Fluid contamination — Determination of particulate contamination by the gravimetric method*
- [3] ISO 6618, *Petroleum products and lubricants — Determination of acid or base number — Colour-indicator titration method*
- [4] ISO 6619, *Petroleum products and lubricants — Neutralization number — Potentiometric titration method*
- [5] ISO 6743-6, *Lubricants, industrial oils and related products (class L) — Classification — Part 6: Family C (Gears)*
- [6] ASTM D4927, *Standard Test Method for Elemental Analysis of Lubricant and Additive Components — Barium, Calcium, Phosphorus, Sulfur, and Zinc by Wavelength-Dispersive X-ray Fluorescence Spectroscopy*
- [7] ASTM D4951, *Standard Test Method for Determination of Additive Elements in Lubricating Oils by Inductively Coupled Plasma Atomic Emission Spectrometry*

---

---

**ICS 75.100**

Price based on 15 pages