Agricultural machinery — Safety —
Part 9:
Seed drills

Matériel agricole — Sécurité —
Partie 9: Semoirs



Reference number
ISO 4254-9:2008(E)

© ISO 2008

PDF disclaimer

This PDF file may contain embedded typefaces. In accordance with Adobe's licensing policy, this file may be printed or viewed but shall not be edited unless the typefaces which are embedded are licensed to and installed on the computer performing the editing. In downloading this file, parties accept therein the responsibility of not infringing Adobe's licensing policy. The ISO Central Secretariat accepts no liability in this area.

Adobe is a trademark of Adobe Systems Incorporated.

Details of the software products used to create this PDF file can be found in the General Info relative to the file; the PDF-creation parameters were optimized for printing. Every care has been taken to ensure that the file is suitable for use by ISO member bodies. In the unlikely event that a problem relating to it is found, please inform the Central Secretariat at the address given below.



COPYRIGHT PROTECTED DOCUMENT

© ISO 2008

All rights reserved. Unless otherwise specified, no part of this publication may be reproduced or utilized in any form or by any means, electronic or mechanical, including photocopying and microfilm, without permission in writing from either ISO at the address below or ISO's member body in the country of the requester.

ISO copyright office
Case postale 56 • CH-1211 Geneva 20
Tel. + 41 22 749 01 11
Fax + 41 22 749 09 47
E-mail copyright@iso.org
Web www.iso.org

Published in Switzerland

Contents

Page

Foreword	iv
Introduction	v
1 Scope	1
2 Normative references	2
3 Terms and definitions	2
4 Safety requirements and/or protective measures	2
4.1 General	2
4.2 Controls	3
4.3 Swivelling and folding components	3
4.4 Hoppers	5
4.5 Loading	5
4.6 Single seed drills	8
4.7 Blower	8
4.8 Flow rate calibration system	8
4.9 Hitching and clearance zone	8
4.10 Noise	8
5 Verification of safety requirements or protective measures	10
6 Information for use	10
6.1 Operator's manual	10
6.2 Safety and instructional signs	11
Annex A (informative) List of significant hazards	12
Annex B (informative) Examples of seed drills	14
Annex C (informative) Stability of the tractor-seed drill combination	17
Bibliography	18

Foreword

ISO (the International Organization for Standardization) is a worldwide federation of national standards bodies (ISO member bodies). The work of preparing International Standards is normally carried out through ISO technical committees. Each member body interested in a subject for which a technical committee has been established has the right to be represented on that committee. International organizations, governmental and non-governmental, in liaison with ISO, also take part in the work. ISO collaborates closely with the International Electrotechnical Commission (IEC) on all matters of electrotechnical standardization.

International Standards are drafted in accordance with the rules given in the ISO/IEC Directives, Part 2.

The main task of technical committees is to prepare International Standards. Draft International Standards adopted by the technical committees are circulated to the member bodies for voting. Publication as an International Standard requires approval by at least 75 % of the member bodies casting a vote.

Attention is drawn to the possibility that some of the elements of this document may be the subject of patent rights. ISO shall not be held responsible for identifying any or all such patent rights.

ISO 4254-9 was prepared by Technical Committee ISO/TC 23, *Tractors and machinery for agriculture and forestry*, Subcommittee SC 3, *Safety and comfort*.

This second edition cancels and replaces the first edition (ISO 4254-9:1992), which has been technically revised.

ISO 4254 consists of the following parts, under the general title *Agricultural machinery — Safety*:

- *Part 1: General requirements*
- *Part 3: Tractors* ¹⁾
- *Part 5: Power-driven soil working machines*
- *Part 6: Sprayers and liquid fertilizer distributors*
- *Part 7: Combine harvesters, forage harvesters and cotton harvesters*
- *Part 8: Solid fertilizer distributors*
- *Part 9: Seed drills*
- *Part 10: Rotary tedders and rakes*
- *Part 11: Pick-up balers*
- *Part 12: Rotary disc and drum mowers and flail-mowers*

Part 4, *Forestry winches*, has been revised and replaced by ISO 19472 ²⁾.

1) Under the general title *Tractors and machinery for agriculture and forestry — Technical means for ensuring safety*. To be replaced by ISO 26322 (all parts), *Tractors for agriculture and forestry — Safety*.

2) ISO 19472, *Machinery for forestry — Winches — Dimensions, performance and safety*.

Introduction

The structure of safety standards in the field of machinery is as follows.

- a) Type-A standards (basic standards) give basic concepts, principle for design, and general aspects that can be applied to machinery;
- b) Type-B standards (generic safety standards) dealing with one or more safety aspect(s) or one or more type(s) of safeguards that can be used across a wide range of machinery:
 - type-B1 standards on particular safety aspects (e.g. safety distances, surface temperature, noise);
 - type-B2 standards on safeguards (e.g. two-hand controls, interlocking devices, pressure sensitive devices, guards);
- c) Type-C standards (machinery safety standards) dealing with detailed safety requirements for a particular machine or group of machines.

This part of ISO 4254 is a type-C standard as stated in ISO 12100-1.

When provisions of this type-C standard are different from those which are stated in type-A or type-B standards, the provisions of this type-C standard take precedence over the provisions of the other standards for machines that have been designed and built according to the provisions of this type-C standard.

The machinery concerned and the extent to which hazards, hazardous situations and events are covered are indicated in the scope of this part of ISO 4254. These hazards are specific to seed drills.

Significant hazards that are common to all the agricultural machines (self-propelled, mounted, semi-mounted and trailed) are dealt with in ISO 4254-1.

Agricultural machinery — Safety —

Part 9: Seed drills

1 Scope

This part of ISO 4254, used together with ISO 4254-1, specifies the safety requirements, and their verification for design and construction, of mounted, semi-mounted, trailed or self-propelled seed drills, including the seeding function of combined seed and fertilizer drills, used in agriculture and horticulture. In addition, it specifies the type of information on safe working practices (including residual risks) to be provided by the manufacturer.

When requirements of this part of ISO 4254 are different from those which are stated in ISO 4254-1 the requirements of this part of ISO 4254 take precedence over the requirements of ISO 4254-1.

This part of ISO 4254 deals with all the significant hazards (as listed in Annex A), hazardous situations and events relevant to seed drills, used as intended and under the conditions foreseen by the manufacturer, excepting the hazards arising from:

- external influences on electrical equipment;
- failure of energy supply;
- failure, malfunction of control system;
- break-up of parts rotating at high speed;
- equipment for loading seeds (and fertilizer).

This part of ISO 4254 is not applicable to seed drills with integrated and inseparable powered soil-working tools (see 3.2),

This part of ISO 4254 is not applicable to environmental hazards or electromagnetic compatibility; neither is it applicable to hazards related to maintenance or repairs carried out by professional service personnel.

NOTE Specific requirements related to road traffic regulations are not taken into account in this International Standard.

This part of ISO 4254 is not applicable to seed drills which are manufactured before the date of its publication.

2 Normative references

The following referenced documents are indispensable for the application of this document. For dated references, only the edition cited applies. For undated references, the latest edition of the referenced document (including any amendments) applies.

ISO 4254-1:2008, *Agricultural machinery — Safety — General requirements*

ISO/TR 11688-1:1995, *Acoustics — Recommended practice for the design of low-noise machinery and equipment — Part 1: Planning*

ISO 12100-1:2003, *Safety of machinery — Basic concepts, general principles for design — Part 1: Basic terminology, methodology*

ISO 13852:1996, *Safety of machinery — Safety distances to prevent danger zones being reached by the upper limbs*

3 Terms and definitions

For the purposes of this document, the terms and definitions given in ISO 12100-1, ISO 4254-1 and the following apply.

3.1

seed drill

machine for sowing seeds in a continuous manner

NOTE Cereals are an example of seed sown in this manner.

3.2

seed drill with integrated and inseparable powered soil-working tools

seed drill as a single machine including the functions of seeding and of soil-working powered tools of which neither the seed drill nor the powered soil-working tools can be used separately

3.3

single seed drill

machine for sowing one seed at a time with equal space between each seed

NOTE 1 Sugar beet is an example of seed sown in this manner.

NOTE 2 Examples of such machines are given in Annex B.

3.4

combined seed and fertilizer drill

machine that simultaneously applies seed and fertilizer

4 Safety requirements and/or protective measures

4.1 General

Machinery shall comply with the safety requirements and/or protective measures of this clause. Unless specified otherwise in this part of ISO 4254, the machine shall comply with the requirements of ISO 4254-1.

The compliance with the safety requirements and/or protective measures shall be verified in accordance with Clause 5 of this part of ISO 4254.

4.2 Controls

4.2.1 Manual controls of seed drills which are intended to be mounted at the rear of soil working machines with powered tools shall meet the following requirements:

- a) adjustments shall be possible with the machine stopped;
- b) manual controls shall be located so that the operator does not need to be at the front of the machine to activate them. This requirement is met if manual controls are accessible to the operator standing on the ground and located outside the shaded area as shown in Figure 1. Markers are excluded from the outer limits of the seed drill. See also 6.1 a).

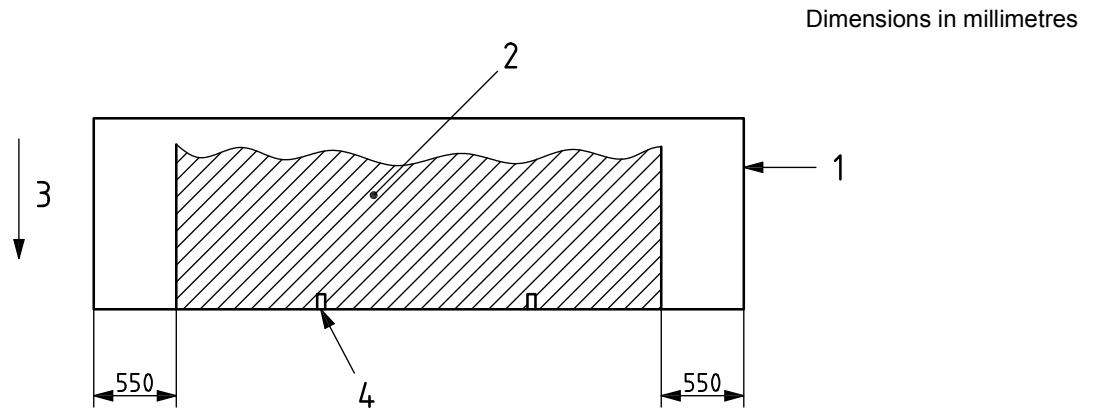

Key

- 1 outer limits of the seed drill
- 2 area in which the manual controls for the adjustment shall not be located
- 3 forward direction
- 4 lower coupling points of the machine, if provided

Figure 1 — Unacceptable location of manual controls for adjustments
(machines which are intended to be mounted on the rear of soil-working machines with powered tools)

4.2.2 In other cases, manual controls for the adjustments located on the machine shall meet the following requirements:

- a) adjustments shall be possible with the machine stopped;
- b) in cases where the direct view of a control(s) at the front of the machine is obscured from the (tractor-) operator station, the manual controls accessible to the operator standing on the ground or on a step provided for adjusting, maintenance or loading, shall be located outside the shaded area as shown in Figure 2. See also 6.1 a).

4.3 Swivelling and folding components

4.3.1 In cases where the implement exceeds 4 m in elevation in either operation or transport or at any time when folded elements are being raised to, or lowered from, the transport position, a safety sign shall be provided to inform of the hazard of power-line entanglement.

A suitable safety message warning of the hazard of contact with overhead power lines shall be included in the operator's manual.

4.3.2 In the case of powered operation of swivelling or folded elements, the control shall be of the hold-to-run type and the control shall be located outside of the swivelling and/or folding zones.

Dimensions in millimetres

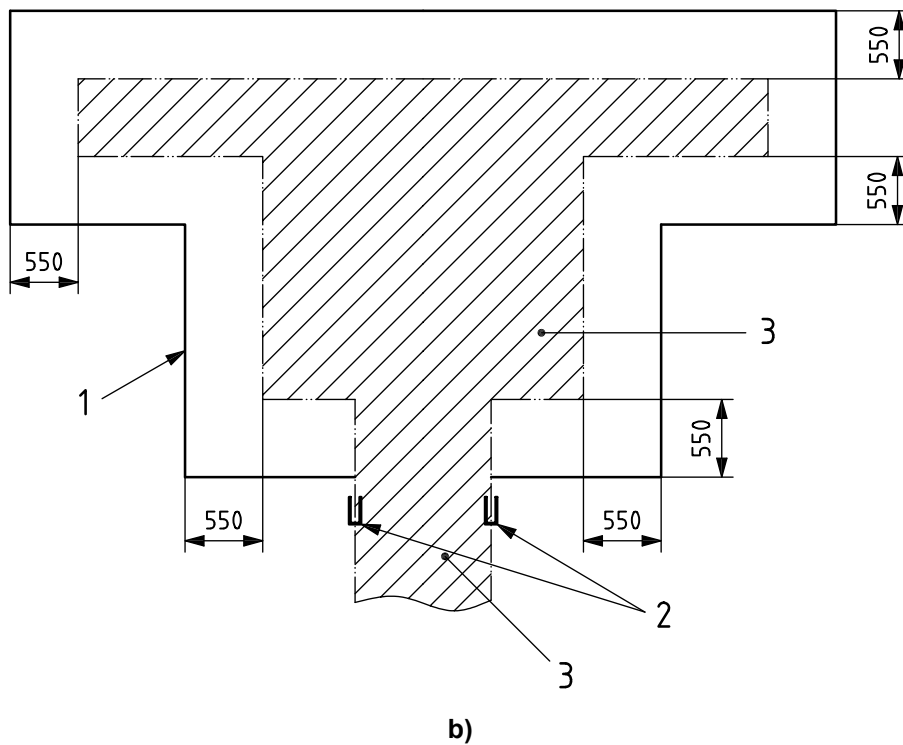
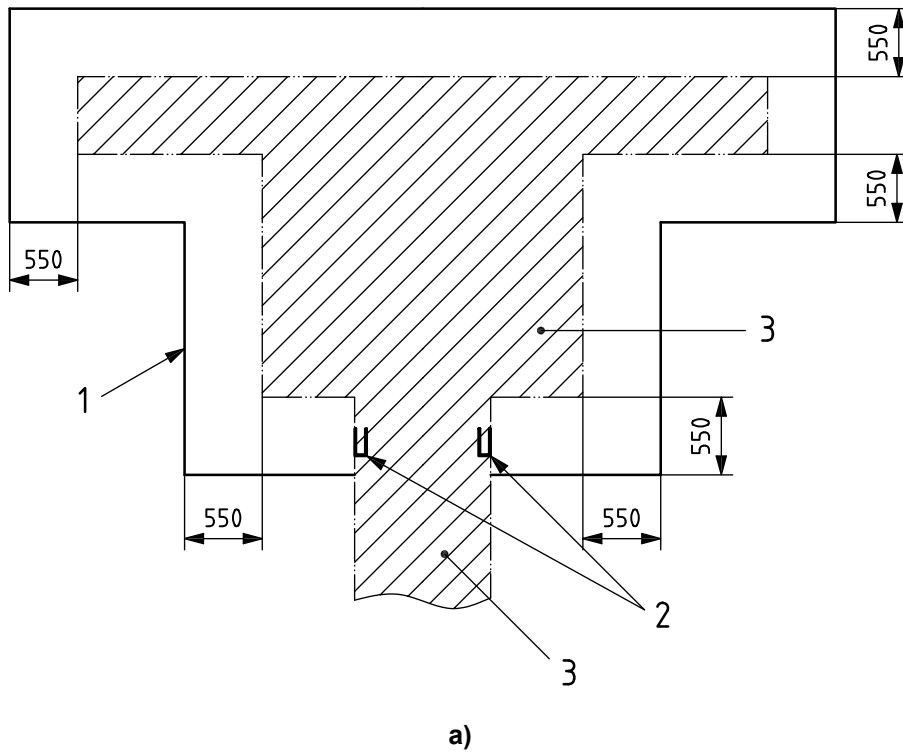

Key

- 1 outer limits of the machine
- 2 lower coupling points
- 3 area where the manual controls for the adjustments shall not be located

Figure 2 — Unacceptable location of manual controls for adjustments (other machines)

4.3.3 Elements folded or swiveled to reduce transport width and/or height shall have a device for retaining in the transport position. This may be achieved by a mechanical device, a hydraulic locking device, by gravity in folding over centre, or by other means.

4.3.3.1 The device shall comply with ISO 4254-1:2008, 4.8. See also 6.1 l) of this part of ISO 4254.

4.3.3.2 If the device is a hydraulic lock-out valve not directly fitted to the hydraulic cylinder, the burst pressure of the hoses or lines between the valve and the cylinder shall be at least 4 times the hydraulic system operating pressure.

4.3.3.3 In the case of a mechanical device, the device shall be strong enough to withstand forces that can be applied on it during the maneuvering of the folded or drawn-in elements through actuation of the swiveling or folding control.

4.3.3.4 The unlocking and the unfolding device of folded or swiveled elements shall be controlled by separate operator actions.

4.4 Hoppers

4.4.1 A hopper cover shall be provided. If the mass of the cover is greater than 10 kg, a means shall be provided to retain the cover to the hopper and the cover shall be provided with a handle(s). The handle(s) may be an integral part(s) of the cover, provided it is suitably designed and clearly identified (e.g. by its shape or colour). Shearing and pinching hazards in case of unintentional closing (for example due to wind) shall be avoided.

4.4.2 On hoppers where there are crushing and shearing points or moving components such as rotating agitators or feed augers:

- a) the safety distances given in Tables 1, 3, 4 and 6 of ISO 13852:1996 shall be met. This does not apply if the agitator or auger rotates only when the machine is in ground motion, or in cases where the agitator or auger can be placed in motion while the machine is stationary during diagnostic procedures specified and explained in the operator's manual;
- b) hoppers shall be designed to be self-emptying, or else one or more device(s) (for example a hand rake) shall be provided. A location on the machine in the filling area shall be provided for the storage of this (these) device(s).

See also 6.1 b), 6.1 i) and 6.1 j).

4.5 Loading

4.5.1 Access to loading location

4.5.1.1 For hoppers that are intended for manual loading or loading with bulk seed bags or large bags, the vertical distance between the upper edge of the hopper at the loading location and the surface of the ground or a platform provided for loading shall not exceed 1 250 mm (see Figure 3) when the seed drill is in the loading position defined in the operator's manual. See also 6.1 d) and 6.1 o)

4.5.1.2 If a platform is provided for manual loading and/or levelling the seed in the hopper, this platform shall be continuous, unless prevented by the construction of the seed drill. In this case, the platform may consist of several parts. In case the platform is narrower than the hopper, provisions to indicate the end of a platform to the operator shall be provided. These provisions shall not constitute an obstacle of access.

4.5.1.3 In addition, the platform shall meet the following requirements:

- the minimum width of the platform shall be 450 mm, the minimum depth from back to front shall be 300 mm, and the minimum area shall be 0,18 m² except for single seed drills with a central hopper. For these machines, the minimum width shall be 240 mm and the minimum depth shall be 600 mm [see Figures 4 a), 4 b) and 4 c)]. For single seed drills with a central hopper [see Figure 4 c)], there shall be at least one central platform when the width of the hopper is ≤ 1 500 mm and at least two platforms when the width of the hopper is > 1 500 mm;

ISO 4254-9:2008(E)

- the distance between the edge of the hopper or the edge of the opened cover and the vertical plane through the edge of the platform shall be ≤ 200 mm (see Figure 3);
- handholds, handrails, guardrails or barrier type safeguards shall be provided if necessary to minimize falling during normal loading and servicing of the hopper, unless similar protection is provided by other parts of the equipment. This requirement is met by either
 - a handrail or handhold(s) positioned between the hopper and the platform, or
 - a guardrail provided at the rear of the platform. In such cases the guardrail shall consist of a top rail, mid rail and foot guard and shall be dimensioned according to ISO 4254-1, 4.5.2.2.

See also 6.1 o) of this part of ISO 4254.

Dimensions in millimetres

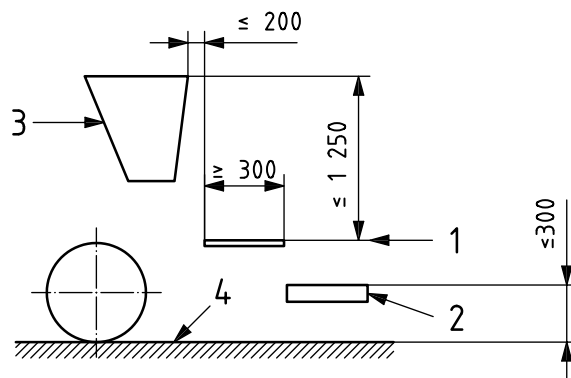

Key

- | | |
|------------|----------|
| 1 platform | 3 hopper |
| 2 step | 4 ground |

Figure 3 — Loading location

Dimensions in millimetres

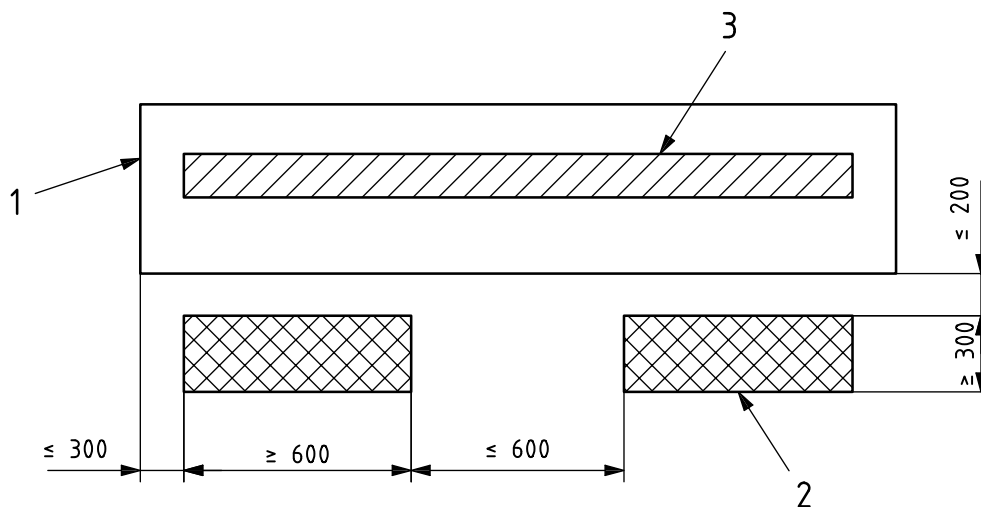

a) Seed drills with hopper for loading and levelling over the whole width

Figure 4 (continued)

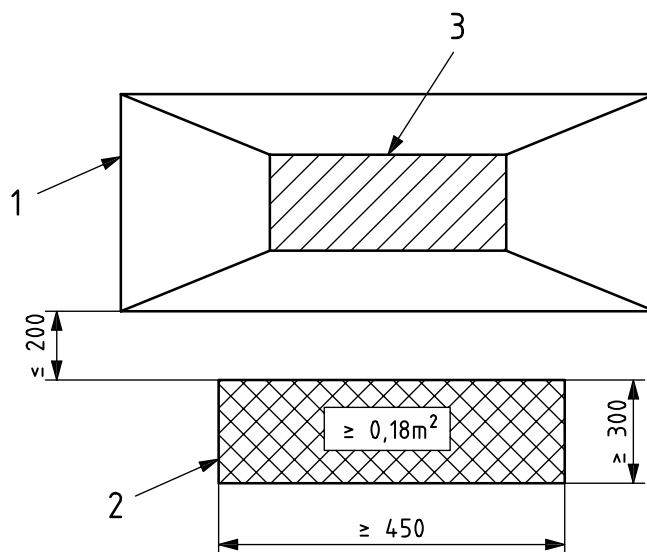

b) Seed drills with hopper for centralised loading

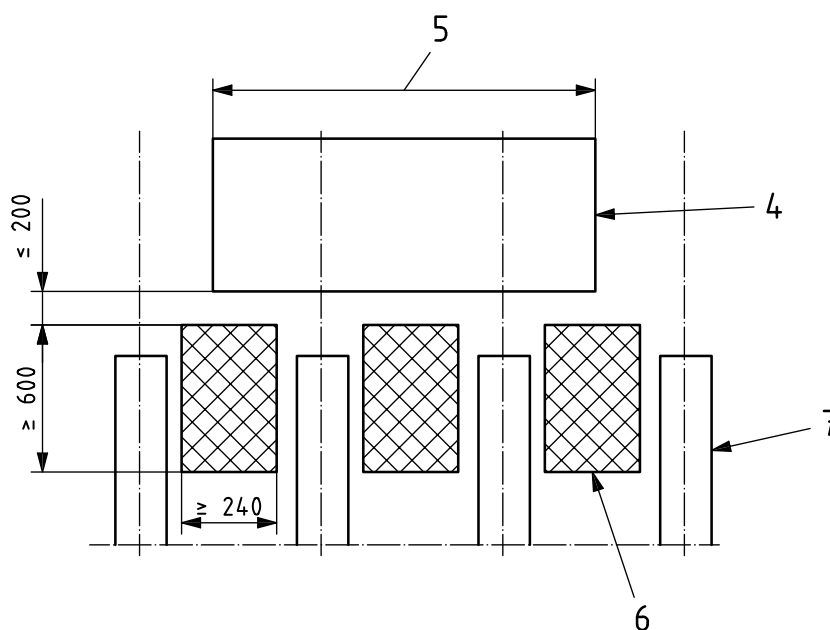

c) Single seed drills with a central hopper

Key

- 1 hopper
- 2 platform
- 3 area of agitator or feed auger
- 4 contour of hopper opening
- 5 width of the hopper
- 6 platform
- 7 seeding unit

NOTE For single seed drills with a central hopper, the minimum number of platforms is linked to the width of the hopper. See 4.5.1.3.

Figure 4 — Dimensions of platforms

4.5.2 Boarding means to manual loading location

The approach to the loading location shall be freely accessible so that the operator does not need to climb over or on to machine components in order to reach the boarding means.

Boarding means shall meet the requirements of ISO 4254-1:2008, 4.5.1 or 4.6.

4.5.3 Boarding means to mechanically loading locations

Boarding means to service locations shall meet the requirements of ISO 4254-1:2008, 4.6.

4.6 Single seed drills

In addition to the requirements given in 4.4.2, the following requirement applies to single seed drills designed to accommodate a ride-on operator.

Any drive part (shaft, pinion, drive chains) which is located at a distance < 850 mm from the ride-on operator's position shall be guarded against drawing in, trapping or entanglement hazards.

4.7 Blower

When a seed drill is fitted with a blower, the blower shall be placed or protected in such a way that when the machine is operating, it shall not be able to draw in or discharge foreign matter which could injure the operator.

The intake area of the blower shall be covered by fixed guards.

4.8 Flow rate calibration system

When a seed drill is supplied with a flow rate calibration system, it shall be possible for the operator to use it without going beneath the machine during the calibration test, while the seed is falling or the machine is working.

4.9 Hitching and clearance zone

For mounted machines, a sufficient clearance between the machine and the tractor (or the machine and the soil-working machine) shall be ensured for the connection of the driving elements (e.g. transmission), if provided, and/or the steering elements (e.g. electric/hydraulic remote control). This shall be achieved by

- an increase of the clearance zone given in Figure 5 at least on one side so that it is possible to connect the driving and/or steering elements after having coupled the seed drill, or
- design of the driving and steering elements so that their connection is possible before coupling the seed drill in a comparable clearance zone according to Figure 5.

See also 6.1 n).

4.10 Noise

4.10.1 Noise reduction by design

The machine shall be designed to generate a noise level as low as practicable. The main sources causing noise are:

- blower (applicable only for pneumatic machines);
- drilling device;
- vibrating surfaces.

Machines shall be designed and constructed taking into account the available information and technical measures to control noise at source at the design stage, as described in ISO/TR 11688-1.

NOTE ISO/TR 11688-2 gives useful information on noise generation mechanisms in machinery.

4.10.2 Noise reduction by information

If after taking all possible technical measures for reducing noise at the design stage a manufacturer considers that further protection of the operator is necessary, then adequate information shall be given in the operator's manual.

4.10.3 Noise emission values

Noise emission values, if required to be declared, shall be determined in accordance with Annex B of ISO 4254-1:2008.

Dimensions in millimetres

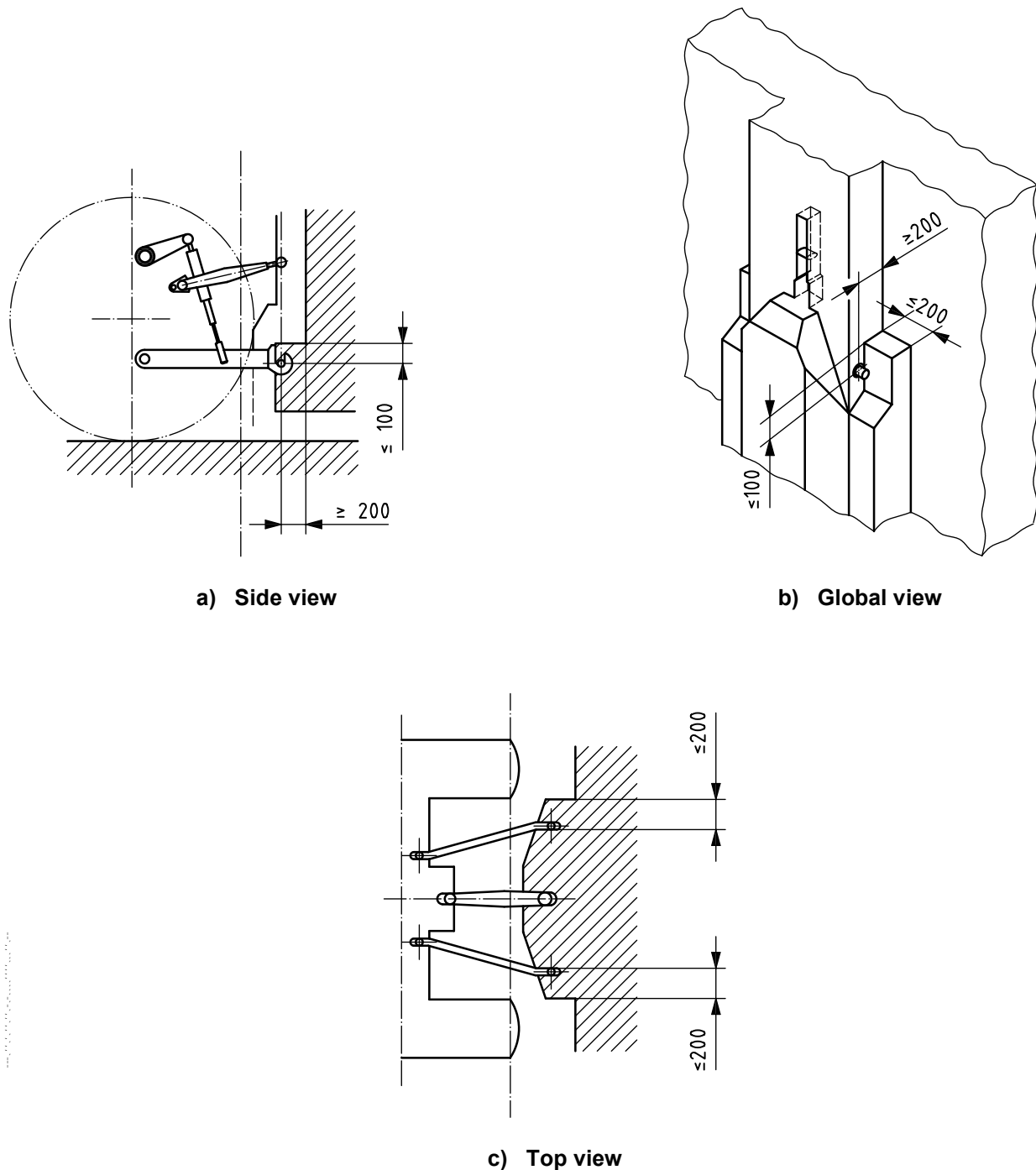

Figure 5 — Clearance zone

5 Verification of safety requirements or protective measures

See Table 1.

Table 1 — List of safety requirements and/or protective measures and their verification

Clause/subclause	Verification		
	Inspection	Mesurement	Procedure/reference
4.2.1 b)	X	X	—
4.3.1	—	X	The height of 4 m shall be measured with the machine on horizontal, level ground.
4.3.3.1	X	—	—
4.4.1	X	—	—
4.4.2	X	X	—
4.5.1.1	—	X	—
4.5.1.2	X	—	—
4.5.1.3	X	X	—
4.7	X	—	—
4.8	X	—	—
4.9	X	X	—

6 Information for use

6.1 Operator's manual

The operator's manual shall comply with the requirements of ISO 4254-1:2008, 8.1.3 and the following information shall be included, if relevant:

- a) hazards resulting from a combination, association or coupling of equipment, in particular with soil working machines (see 4.2 of this part of ISO 4254);
- b) hazards caused by moving components in the hopper (see 4.4 of this part of ISO 4254);
- c) that nobody shall stand nearby the machine when it is moving (in particular the hazards related to the contact with markers shall be pointed out) (see 4.2 of this part of ISO 4254);
- d) the safe procedures for the adjustments, calibration and loading (see 4.5.1, 4.8 of this part of ISO 4254);
- e) that the operator shall avoid wearing loosely fitting clothes which could become entangled with moving parts (see 4.3.2 of this part of ISO 4254);
- f) the need to wear personal protective equipment (PPE) when necessary (see 4.8 of this part of ISO 4254);
- g) the hazards during removal and refitting of the seed units and the instructions to be followed for their handling (see 4.6 of this part of ISO 4254);
- h) the need to use a PTO drive shaft equipped with a guard in good condition (see 4.6 of this part of ISO 4254);

- i) the conditions of use to prevent blockages occurring (e.g. to avoid the use of damp seed) (see 4.4 of this part of ISO 4254);
- j) the hazards relating to clearing blockages (e.g. blockages in the coulters due to incorrect lowering of the machine to the ground) and the procedures to be followed (see 4.4 of this part of ISO 4254);
- k) the risk of unintentional contact with overhead power lines where this is possible during application operations e.g. due to uneven ground or use of swivelling and movable components (see 4.3.1 of this part of ISO 4254);
- l) the need to check that the unlocking procedure does not cause the swivelling and movable components to fall down in an uncontrolled way (see 4.3.3 of this part of ISO 4254);
- m) which seed units have to be fitted on the outside of the machine in case of interchangeable seeding units (see 4.6 of this part of ISO 4254);
- n) instructions concerning the use of automatic and semi-automatic hitching, when provided (see 4.9 of this part of ISO 4254);
- o) the need to follow advice concerning manual handling of heavy loads and/or the need to follow correct procedures for sack handling and lifting (see 4.5 of this part of ISO 4254);
- p) that people shall not ascend onto the machine while operating;
- q) the fact that the load can influence tractor manoeuvrability and that if the balance of the machine is affected when partially unloaded, then care shall be taken (see Annex C of this part of ISO 4254, which gives recommendations for calculations to be used to ensure stability of the tractor/seed drill combination).

6.2 Safety and instructional signs

Safety and instructional signs shall comply with the requirements of ISO 4254-1:2008, 8.2. In particular, safety sign(s) shall be provided drawing attention to:

- hazards associated with mounting or riding on the machine while it is moving;
- hazards associated with moving parts;
- hazards caused by rotating feed augers and agitators within the hopper;
- the risk of power line entanglement for machines that exceed 4 m in elevation in any operation mode.

Annex A (informative)

List of significant hazards

Table A.1 specifies the significant hazards, the significant hazardous situations and the significant hazardous events that have been identified as being significant for this types of machines covered by this part of ISO 4254 and which may require specific action by the designer or manufacturer to eliminate or to reduce the risk.

Table A.1 — List of significant hazards

No. ^a	Hazard	Hazardous situation and event	Clause/subclause of ISO 4254-1:2008	Clause/subclause of this part of ISO 4254
A.1	Mechanical hazards			
A.1.1	Crushing hazard	— swivelling and movable components	4.5.1.2, 4.14, 5.1.4	4.3; 6
		— cover of the hopper		4.4; 6
		— calibration system		4.8; 6
		— hitching		4.9; 6
A.1.2	Shearing hazard	— swivelling and movable components	4.8, 5.1.4	4.3; 6
		— cover of the hopper		4.4; 6
A.1.3	Cutting or severing hazard	— swivelling and movable components	4.1, 4.5.1.2, 4.14	4.3; 6
		— cover of the hopper		4.4; 6
A.1.4	Entanglement hazard	— cover of the hopper	4.1, 4.14	4.4; 6
		— blower		4.7; 6
A.1.5	Drawing-in or trapping hazard	— blower	—	4.7; 6
A.1.6	Impact hazard	— cover of the hopper	4.1, 4.8, 4.14	4.4; 6
		— hitching		4.9; 6
A.1.9	High pressure fluid injection or ejection hazard	— rupture of pressurised hoses	4.10	—
A.2	Electrical hazards			
A.2.2	Contact of persons with parts which have become live under faulty conditions (direct and indirect contact)	— overhead power line	—	4.3.1; 6
A.4	Hazards generated by noise			
A.4.1	Hearing loss (deafness), other physiological disorders (e.g. loss of balance, loss of awareness)	— noise	4.2, Annex B	4.10

Table A.1 (continued)

No. ^a	Hazard	Hazardous situation and event	Clause/subclause of ISO 4254-1:2008	Clause/subclause of this part of ISO 4254
A.5	Hazards generated by materials and substances			
A.5.1	Hazards from contact with or inhalation of harmful fluids, gases, mists, fumes, and dusts	— fuel	4.12, 5.4, 8.1	6
		— operating fluid		6
		— seeds		6
A.6	Hazards generated by neglecting ergonomic principles in machinery design			
A.6.1	Unhealthy postures or excessive efforts	— controls	4.4	4.2; 6
		— access to loading and hopper		4.5; 6
		— hitching		4.9; 6
A.6.2	Inadequate consideration of hand-arm or foot-leg anatomy	— controls	4.4	4.2; 6
		— accesses to loading		4.5; 6
		— hitching		4.9; 6
A.6.7	Inadequate design, location or identification of manual controls	— controls	4.4	4.2; 6
A.13	Errors of fitting	— seeding units	—	4.6; 6
A.15	Ejected objects	— blower	4.10	4.7; 6
A.16	Loss of stability/overturning of machinery	— lack of stability	5.2.1, 6.2.1	—
A.17	Slip, trip and fall of persons (related to machinery)	— access to loading	—	4.5; 6
Additional hazards, hazardous situations and hazardous events due to mobility				
A.18	Related to the travelling function			
A.18.1	Movement when starting the engine	— swivelling and movable components	5.1.8	—
A.18.3	Movement without all parts in a safe position	— swivelling and movable components	—	4.3; 6
A.20	Due to the control system			
A.20.1	Inadequate location and mode of operation of manual controls	— controls	4.4	4.2; 6
		— swivelling and movable components		4.3; 6
A.22	Due to the power source and to the transmission of power			
A.22.2	Hazards from transmission of power	— drive	—	—
A.22.3	Hazards from hitching	— hitching	5.2.1, 6.3	4.9; 6
^a	With reference to ISO 4254-1:2008, Table A.1.			

Annex B
(informative)

Examples of seed drills

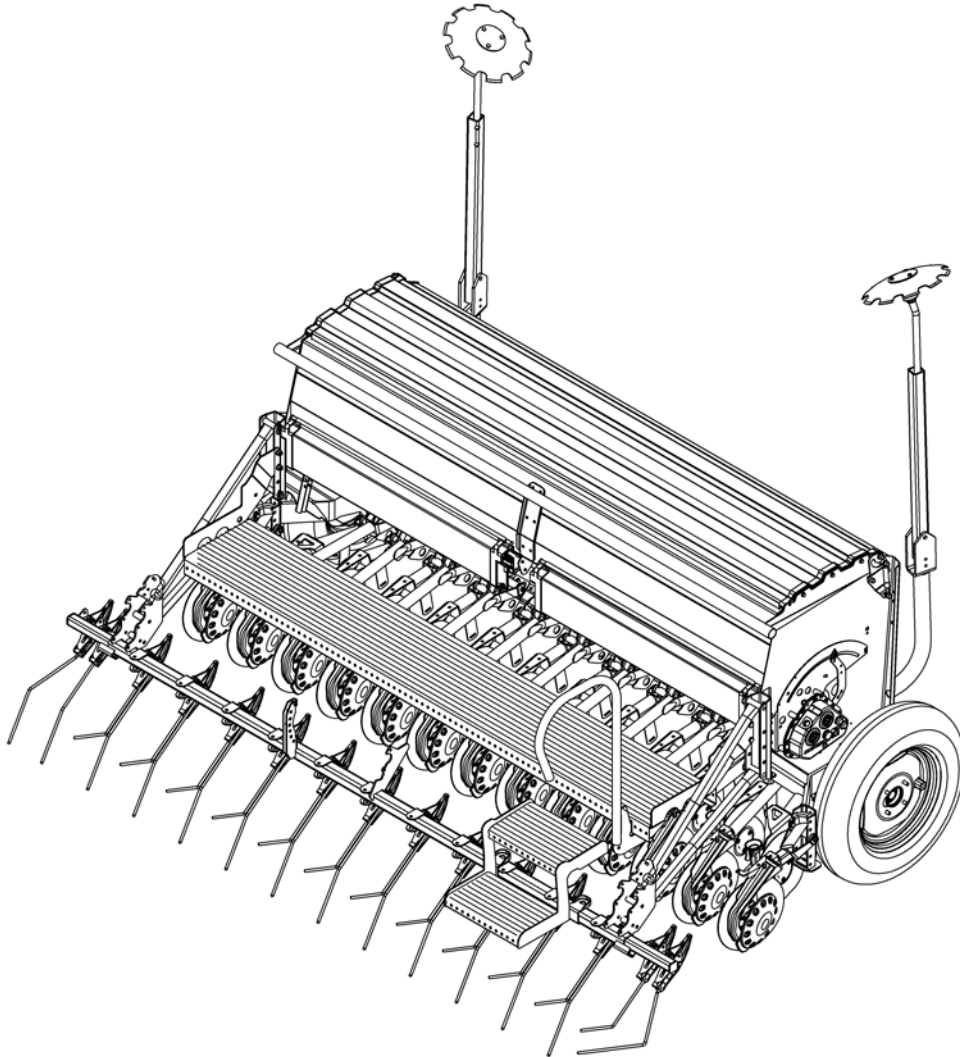

Figure B.1 — Mechanical seed drill

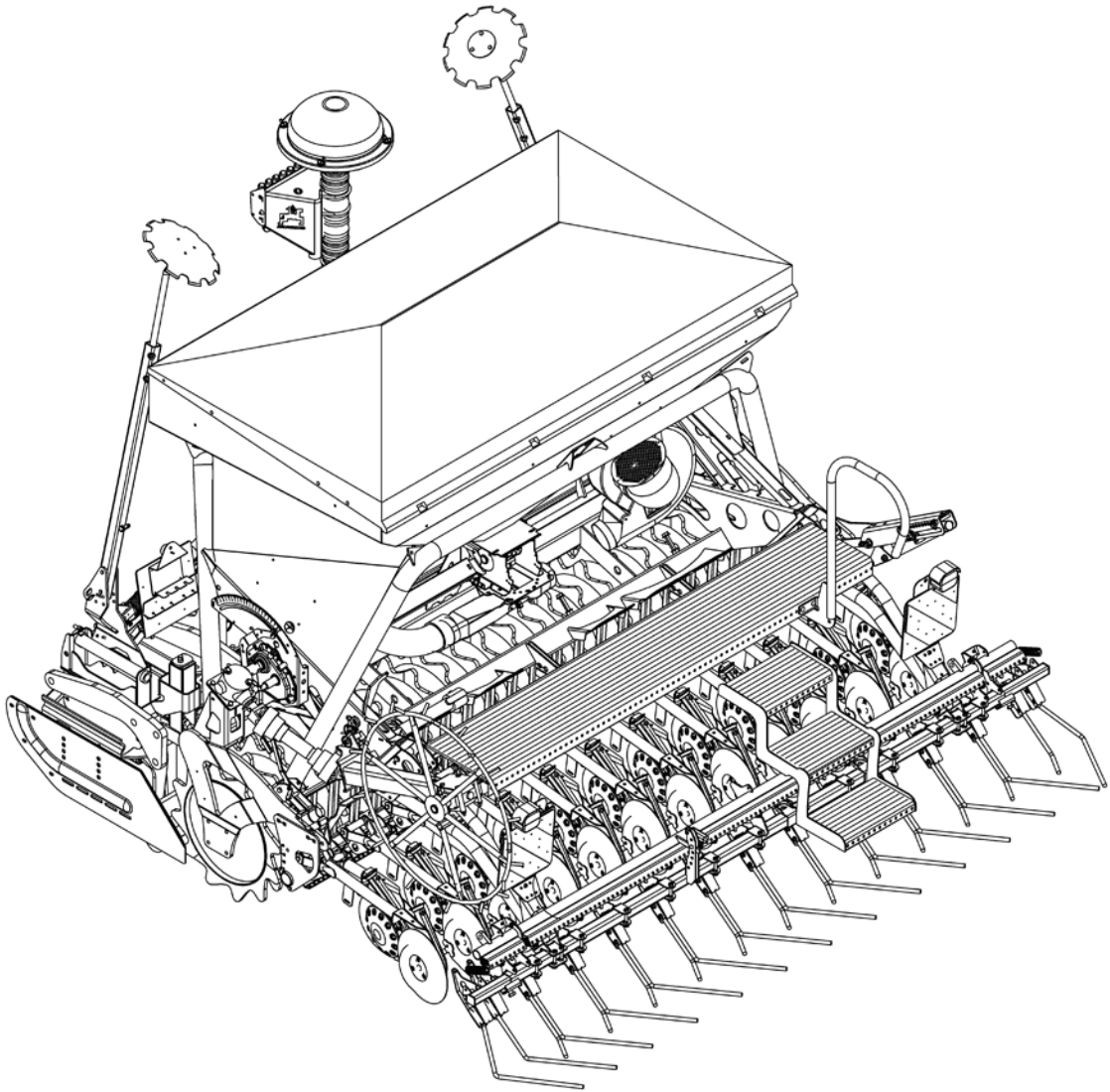

Figure B.2 — Pneumatic seed drill

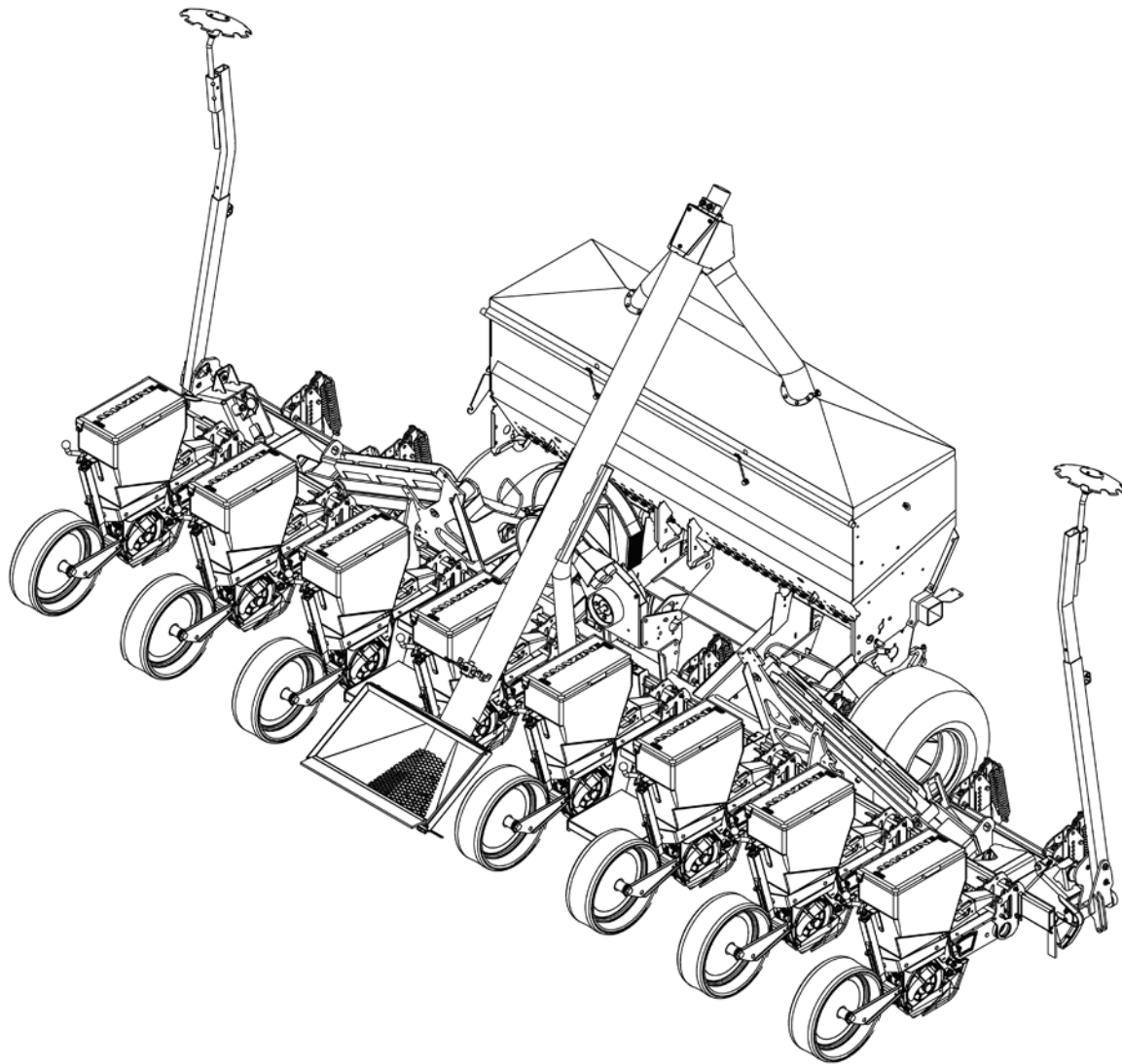

Figure B.3 — Single seed drill

Annex C (informative)

Stability of the tractor-seed drill combination

This annex is related to 6.1.q), in which there is the requirement to give information concerning the possible loss of stability of the tractor due to the connection with the seed drill.

The following text is a suggestion to the manufacturer to enable them to provide adequate and complete information.

The example suggested refers to a seed drill mounted on a tractor.

Due to the mass of the machine itself and of the materials present in the hopper, the tractor-seed drill combination may become unstable. In order to verify the total stability, the following expression can be applied for the calculation of the minimum ballasting at the front, $I_{F,\min}$, in kilograms, which allows the possibility of a load on the front axle equal to 20 % of the unladen mass of the tractor:

$$I_{F,\min} = \frac{[I_R \times (c + d)] - (T_F \times b) + (0,2 \times T_E \times b)}{a + b}$$

See Figure C.1.

NOTE Rear mounted implement and front/rear combinations are considered for this calculation.

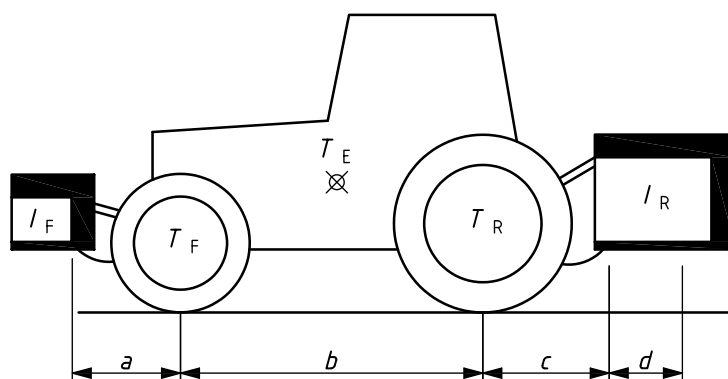

Key

- T_E [kg] mass of unladen tractor^a
- T_F [kg] front axle load of unladen tractor^a
- T_R [kg] rear axle load of unladen tractor^a
- I_F [kg] combined mass of front mounted implement/front ballast^b
- I_R [kg] combined mass of rear mounted implement/rear ballast^b
- a [m] distance from centre of gravity for combined front mounted implement/front ballast to front axle centre^{b, c}
- b [m] tractor wheelbase^{a, c}
- c [m] distance from rear axle centre to centre of lower link balls^{a, c}
- d [m] distance from centre of lower link balls to centre of gravity for combined rear mounted implement/rear ballast^b

- ^a See instruction handbook of the tractor.
- ^b See catalogue and/or instruction handbook of the implement.
- ^c To be measured.

Figure C.1 — Example of instructions for stability of the tractor–seed drill combination

Bibliography

- [1] ISO/TR 11688-2, *Acoustics — Recommended practice for the design of low-noise machinery and equipment — Part 2: Introduction to the physics of low-noise design*
- [2] ISO 12100-2, *Safety of machinery — Basic concepts, general principles for design — Part 2: Technical principles*

© ISO 2008

ICS 65.060.30

Price based on 18 pages