

---

---

**Agricultural machinery — Safety —**  
**Part 7:**  
**Combine harvesters, forage harvesters**  
**and cotton harvesters**

*Matériel agricole — Sécurité —*

*Partie 7: Moissonneuses-batteuses, récolteuses-hacheuses-chargeuses de fourrage et récolteuses de coton*



Reference number  
ISO 4254-7:2008(E)

© ISO 2008

**PDF disclaimer**

This PDF file may contain embedded typefaces. In accordance with Adobe's licensing policy, this file may be printed or viewed but shall not be edited unless the typefaces which are embedded are licensed to and installed on the computer performing the editing. In downloading this file, parties accept therein the responsibility of not infringing Adobe's licensing policy. The ISO Central Secretariat accepts no liability in this area.

Adobe is a trademark of Adobe Systems Incorporated.

Details of the software products used to create this PDF file can be found in the General Info relative to the file; the PDF-creation parameters were optimized for printing. Every care has been taken to ensure that the file is suitable for use by ISO member bodies. In the unlikely event that a problem relating to it is found, please inform the Central Secretariat at the address given below.



**COPYRIGHT PROTECTED DOCUMENT**

© ISO 2008

All rights reserved. Unless otherwise specified, no part of this publication may be reproduced or utilized in any form or by any means, electronic or mechanical, including photocopying and microfilm, without permission in writing from either ISO at the address below or ISO's member body in the country of the requester.

ISO copyright office  
Case postale 56 • CH-1211 Geneva 20  
Tel. + 41 22 749 01 11  
Fax + 41 22 749 09 47  
E-mail [copyright@iso.org](mailto:copyright@iso.org)  
Web [www.iso.org](http://www.iso.org)

Published in Switzerland

# Contents

Page

Foreword.....	v
Introduction .....	vi
<b>1 Scope .....</b>	<b>1</b>
<b>2 Normative references .....</b>	<b>1</b>
<b>3 Terms and definitions.....</b>	<b>2</b>
<b>4 List of significant hazards .....</b>	<b>4</b>
<b>5 Safety requirements and/or measures for all machines.....</b>	<b>14</b>
5.1 General.....	14
5.2 Controls .....	14
5.3 Operator's work station.....	15
5.4 Boarding means for other than operator's work station .....	22
5.5 Folding elements .....	23
5.6 Interchangeable and detachable harvesting devices .....	24
5.7 Automatic guidance systems .....	24
5.8 Hot surfaces .....	24
5.9 Service and maintenance.....	24
5.10 Fire hazard.....	25
5.11 Overhead power lines.....	26
5.12 Header drive .....	26
5.13 Header/feeding elements drive reverser .....	26
5.14 Noise .....	26
5.15 Hydraulic components and fittings.....	26
5.16 Electric equipment.....	26
<b>6 Additional requirements for combine harvesters .....</b>	<b>27</b>
6.1 General.....	27
6.2 Cabin .....	27
6.3 Cutting mechanism, feed augers, reel.....	27
6.4 Grain tank and grain handling systems .....	27
6.5 Maize harvesting attachment.....	29
6.6 Rear straw chopper, straw spreader and chaff spreader .....	31
6.7 Stone trap .....	33
6.8 Storage of sickle bars.....	33
<b>7 Additional requirements for forage harvesters .....</b>	<b>34</b>
7.1 Operator's work station.....	34
7.2 Infeed mechanism.....	34
7.3 Cutterhead drive .....	35
7.4 Alarm for run-down of cutterhead and blower .....	36
7.5 Knife sharpening device .....	36
<b>8 Additional requirements for cotton harvesters .....</b>	<b>36</b>
8.1 Harvest mechanism, feed augers, reel .....	36
8.2 Basket (cotton stripper and cotton picker) .....	36
8.3 Operating fluids .....	37
<b>9 Verification of the safety requirements or protective measures .....</b>	<b>38</b>
<b>10 Information for use .....</b>	<b>40</b>
10.1 Operator's manual .....	40
10.2 Marking .....	42

**Annex A (normative) Identification of hand controls by colour coding ..... 43**  
**Annex B (normative) Noise measurement ..... 44**  
**Bibliography ..... 46**

www.iso.org

## Foreword

ISO (the International Organization for Standardization) is a worldwide federation of national standards bodies (ISO member bodies). The work of preparing International Standards is normally carried out through ISO technical committees. Each member body interested in a subject for which a technical committee has been established has the right to be represented on that committee. International organizations, governmental and non-governmental, in liaison with ISO, also take part in the work. ISO collaborates closely with the International Electrotechnical Commission (IEC) on all matters of electrotechnical standardization.

International Standards are drafted in accordance with the rules given in the ISO/IEC Directives, Part 2.

The main task of technical committees is to prepare International Standards. Draft International Standards adopted by the technical committees are circulated to the member bodies for voting. Publication as an International Standard requires approval by at least 75 % of the member bodies casting a vote.

Attention is drawn to the possibility that some of the elements of this document may be the subject of patent rights. ISO shall not be held responsible for identifying any or all such patent rights.

ISO 4254-7 was prepared by Technical Committee ISO/TC 23, *Tractors and machinery for agriculture and forestry*, Subcommittee SC 7, *Equipment for harvesting and conservation*.

This second edition cancels and replaces the first edition (ISO 4254-7:1995), which has been technically revised.

ISO 4254 consists of the following parts, under the general title *Agricultural machinery — Safety*:

- *Part 1: General requirements*
- *Part 3: Tractors<sup>1)</sup>*
- *Part 5: Power-driven soil working equipment*
- *Part 6: Sprayers and liquid fertilizer distributors*
- *Part 7: Combine harvesters, forage harvesters and cotton harvesters*
- *Part 8: Solid fertilizer distributors*
- *Part 9: Seed drills*
- *Part 10: Rotary tedders and rakes*
- *Part 11: Pick-up balers*
- *Part 12: Rotary disc and drum mowers and flail mowers*

Part 4, *Forestry winches*, was cancelled and replaced by ISO 19472, *Machinery for forestry — Winches — Dimensions, performance and safety*.

---

1) Under the general title *Tractors and machinery for agriculture and forestry — Technical means for ensuring safety*. To be cancelled and replaced by ISO 26322 (all parts), *Tractors and machinery for agriculture and forestry — Safety*.

## Introduction

The structure of safety standards in the field of machinery is as follows.

- a) Type-A standards (basic standards) give basic concepts, principles for design, and general aspects that can be applied to machinery.
- b) Type-B standards (generic safety standards) deal with one or more safety aspect(s) or one or more type(s) of safeguards that can be used across a wide range of machinery:
  - type-B1 standards on particular safety aspects (e.g. safety distances, surface temperature, noise);
  - type-B2 standards on safeguards (e.g. two-hand controls, interlocking devices, pressure sensitive devices, guards);
- c) Type-C standards (machinery safety standards) deal with detailed safety requirements for a particular machine or group of machines.

This part of ISO 4254 is a type-C standard as stated in ISO 12100-1.

When provisions of this type-C standard are different from those which are stated in type-A or type-B standards, the provisions of this type-C standard take precedence over the provisions of the other standards for machines that have been designed and built according to the provisions of this type-C standard.

The machinery concerned and the extent to which hazards, hazardous situations and events are covered are indicated in the scope of this part of ISO 4254. These hazards are specific to combine harvesters, forage harvesters and cotton harvesters.

Significant hazards that are common to all the agricultural machines (self-propelled ride-on, mounted, semi-mounted and trailed) are dealt with in ISO 4254-1.

# Agricultural machinery — Safety —

## Part 7: Combine harvesters, forage harvesters and cotton harvesters

### 1 Scope

This part of ISO 4254, intended to be used together with ISO 4254-1, specifies the safety requirements and their verification for the design and construction of combine harvesters, forage harvesters and cotton harvesters. It describes methods for the elimination or reduction of hazards arising from the intended use of these machines by one person (the operator) in the course of normal operation and service. In addition, it specifies the type of information on safe working practices to be provided by the manufacturer.

When provisions of this part of ISO 4254 are different from those which are stated in ISO 4254-1, the provisions of this part of ISO 4254 take precedence over the provisions of ISO 4254-1 for machines that have been designed and built according to the provisions of this part of ISO 4254.

This part of ISO 4254, taken together with ISO 4254-1, deals with all the significant hazards (as listed in Table 1), hazardous situations and events relevant to combine harvesters, forage harvesters and cotton harvesters, when they are used as intended and under the conditions foreseen by the manufacturer (see Clause 4). It is not applicable to hazards arising from the presence of persons other than the operator, cleaning of the grain tank, and hazards related to vibrations and moving parts for power transmission, except for strength requirements for guards and barriers. In respect of braking and steering, it is applicable only to the ergonomic aspects (e.g. location of brake pedal and steering wheel); no other aspects related to braking and steering are covered. In the case of trailed harvesters, it is applicable only to hazards related to the working process.

**NOTE** Specific requirements related to road traffic regulations are not taken into account in this part of ISO 4254.

This part of ISO 4254 is not applicable to machines manufactured before the date of its publication.

### 2 Normative references

The following referenced documents are indispensable for the application of this document. For dated references, only the edition cited applies. For undated references, the latest edition of the referenced document (including any amendments) applies.

ISO 3600:1996, *Tractors, machinery for agriculture and forestry, powered lawn and garden equipment — Operator's manuals — Content and presentation*

ISO 3767-1, *Tractors, machinery for agriculture and forestry, powered lawn and garden equipment — Symbols for operator controls and other displays — Part 1: Common symbols*

ISO 3767-2, *Tractors, machinery for agriculture and forestry, powered lawn and garden equipment — Symbols for operator controls and other displays — Part 2: Symbols for agricultural tractors and machinery*

ISO 3776-1:2006, *Tractors and machinery for agriculture — Seat belts — Part 1: Anchorage location requirements*

## ISO 4254-7:2008(E)

ISO 3776-2:2007, *Tractors and machinery for agriculture — Seat belts — Part 2: Anchorage strength requirements*

ISO 4253:1993, *Agricultural tractors — Operator's seating accommodation — Dimensions*

ISO 4254-1:2008, *Agricultural machinery — Safety — Part 1: General requirements*

ISO 5131:1996, *Acoustics — Tractors and machinery for agriculture and forestry — Measurement of noise at the operator's position — Survey method*

ISO 5353:1995, *Earth-moving machinery, and tractors and machinery for agriculture and forestry — Seat index point*

ISO 5687:1999, *Equipment for harvesting — Combine harvesters — Determination and designation of grain tank capacity and unloading device performance*

ISO 9533:1989, *Earth-moving machinery — Machine-mounted forward and reverse audible warning alarm — Sound test method*

ISO 11684:1995, *Tractors, machinery for agriculture and forestry, powered lawn and garden equipment — Safety signs and hazard pictorials — General principles*

ISO 12100-1:2003, *Safety of machinery — Basic concepts, general principles for design — Part 1: Basic terminology, methodology*

ISO 12100-2:2003, *Safety of machinery — Basic concepts, general principles for design — Part 2: Technical principles*

ISO 15077:2008, *Tractors and self-propelled machinery for agriculture — Operator controls — Actuating forces, displacement, location and method of operation*

### 3 Terms and definitions

For the purposes of this document, the terms and definitions given in ISO 12100-1 and ISO 4254-1 and the following apply.

#### 3.1 instructional seat

integral or separate seat to allow a trainer or trainee to be seated

#### 3.2 guidance system

automatic system to control machine steering during the harvesting operation

#### 3.3 combine harvester

mobile grain-harvesting machine for cutting, stripping or picking up crops, threshing, separating, cleaning and conveying grain into a grain tank and depositing harvest residue onto the ground

#### 3.4 clean grain and returns handling systems

systems for conveying of clean grain and returns within the machine by augers and/or elevators to the grain tank or threshing/re-threshing system



**3.5****forage harvester**

mobile agricultural machine used to harvest or gather the crop, cut the crop into short parallel lengths and deliver the chopped crop into containers or separate vehicles

NOTE ISO 8909-1 gives detailed definitions of terms related to forage harvesters.

**3.6****cotton harvester**

mobile cotton seed harvesting machine for cleaning as required, handling and conveying seed cotton into a basket and depositing harvest residue onto the ground

**3.7****cotton harvesting unit**

portion of cotton harvester comprising the mechanism for gathering and stripping or picking seed, cotton from a cotton plant

**3.8****compacting device**

elements for compacting the harvested material on a mobile cotton harvester

**3.9****basket**

container used to receive, hold, compact and unload harvested cotton crop material

**3.10****cleaner**

device for separating trash from harvested cotton material on a mobile cotton harvester

**3.11****header**

portion of the combine/forage harvester or cotton harvester comprising the mechanism for gathering, cutting, stripping or picking up the crop

**3.12****operator's work station**

location on the machine that encompasses the driver's position

#### 4 List of significant hazards

Table 1 gives the significant hazard(s), the significant hazardous situation(s) and event(s) covered by this part of ISO 4254 that have been identified by risk assessment as being significant for this type of machine, and which require specific action by the designer or manufacturer to eliminate or to reduce the risk.

Attention is drawn to the necessity to verify that the safety requirements specified in this part of ISO 4254 apply to each significant hazard presented by a given machine and to validate that the risk assessment is complete.

**Table 1 — List of significant hazards associated with combine harvesters, forage harvesters and cotton harvesters**

No. <sup>a</sup>	Hazard	Hazardous situation and event	Clause/subclause of ISO 4254-1:2008	Clause/subclause of this part of ISO 4254
<b>A.1</b>	<b>Mechanical hazard</b>			
A.1.1	Crushing hazard	Clearance to adjacent parts when actuating controls	4.4.3; 5.1.3.1; 5.1.3.3; 5.1.8; 6.1	5.2.1.3; 5.2.2; 5.2.3; 5.3.3, 7.2.5
		Movement of boarding means	4.5.1.1.2; 4.5.1.2.5; 4.5.2.3; 4.5	5.3.5; 5.3.7.3; 5.4
		Design of platforms	4.5.2.2	5.3.7.2
		Working tools	4.7	5.1.2
		Service points, service and maintenance operations, use of supports	4.8; 4.14.1	5.9.4
		Movement of folding elements	4.14.3; 4.14.5; 4.14.6	5.5
		Shearing and pinching points at the operator's work station	5.1.4	5.3.4
		Construction of jack-up points, moving the machine, tie down and jacking operations	5.2	5.9.5
		Lack of stability	6.2	5.1.2
		Mounting of machines	6.2.2; 6.2.3; 6.3	5.6
		Cutting mechanism, feed augers, reel	—	6.3
		Grain tank augers and grain handling systems	—	6.4.1; 6.4.2; 6.4.3; 6.4.4; 6.4.5.1; 6.4.6
		Maize harvesting attachment	—	6.5
		Rear straw chopper, straw spreader, chaff spreader	—	6.6.2; 6.6.3; 6.6.4
		Emptying of stone trap	—	6.7
		Infeed mechanism	—	7.2
		Inspection points, Inspection of drum and fingers	—	8.1.2.1.2
		Basket lowering	—	8.2.1
Compactor auger operation	—	8.2.2		

Table 1 (continued)

No. <sup>a</sup>	Hazard	Hazardous situation and event	Clause/subclause of ISO 4254-1:2008	Clause/subclause of this part of ISO 4254
A.1.2	Shearing hazard	Clearance to adjacent parts when actuating controls	4.4.3; 5.1.3.1; 5.1.3.3; 5.1.8; 6.1	5.2.1.3; 5.2.2; 5.2.3; 5.3.3, 7.2.5
		Movement of boarding means	4.5.1.1.2; 4.5.1.2.5; 4.5.2.3; 4.6	5.3.5; 5.3.7.3; 5.4
		Design of platforms	4.5.2.2	5.3.7.2
		Working tools	4.7	5.1.2
		Service points, service and maintenance operations, use of supports	4.8; 4.14.1	5.9.4
		Movement of folding elements	4.14.3; 4.14.5; 4.14.6	5.5
		Shearing and pinching points at the operator's work station	5.1.4	5.3.4
		Construction of jack-up points, moving the machine, tie down and jacking operations	5.2	5.9.5
		Lack of stability	6.2	5.1.2
		Mounting of machines	6.2.2; 6.2.3; 6.3	5.6
		Cutting mechanism, feed augers, reel	—	6.3
		Grain tank augers and grain handling systems	—	6.4.1; 6.4.2; 6.4.3; 6.4.4; 6.4.5.1; 6.4.6
		Maize harvesting attachment	—	6.5
		Rear straw chopper, straw spreader, chaff spreader	—	6.6.2; 6.6.3; 6.6.4
		Emptying of stone trap	—	6.7
		Infeed mechanism	—	7.2
		Operation of knife sharpening device	—	7.5.1, 7.5.2
		Inspection points, inspection of drum and fingers	—	8.1.2.1.2
Basket lowering	—	8.2.1		
Compactor auger operation	—	8.2.2		

Table 1 (continued)

No. <sup>a</sup>	Hazard	Hazardous situation and event	Clause/subclause of ISO 4254-1:2008	Clause/subclause of this part of ISO 4254
A.1.3	Cutting or severing hazard	Working tools	4.7	5.1.2
		Cutting mechanism, feed augers, reel	—	6.3
		Grain tank augers and grain handling systems	—	6.4.1; 6.4.2; 6.4.3; 6.4.4; 6.4.5.1; 6.4.6
		Maize harvesting attachment	—	6.5
		Rear straw chopper, straw spreader, chaff spreader	—	6.6.2; 6.6.3; 6.6.4
		Storage of sickle bars	—	6.7
		Infeed mechanism	—	7.2
		Operation of knife sharpening device	—	7.5.1, 7.5.2
		Inspection points, inspection of drum and fingers	—	8.1.2.1.2
		Basket lowering	—	8.2.1
		Compactor auger operation	—	8.2.2
A.1.4	Entanglement hazard	Working tools	4.7	5.1.2
		Starting/stopping the engine with engaged drive(s)	5.1.8	5.2.3
		Cutting mechanism, feed augers, reel	—	6.3
		Grain tank augers and grain handling systems	—	6.4.1; 6.4.2; 6.4.3; 6.4.4; 6.4.5.1; 6.4.6
		Maize harvesting attachment	—	6.5
		Infeed mechanism	—	7.2
		Inspection points, inspection of drum and fingers	—	8.1.2.1.2
		Basket lowering	—	8.2.1
		Compactor auger operation	—	8.2.2

Table 1 (continued)

No. <sup>a</sup>	Hazard	Hazardous situation and event	Clause/subclause of ISO 4254-1:2008	Clause/subclause of this part of ISO 4254
A.1.5	Drawing-in or trapping hazard	Working tools	4.7	5.1.2
		Starting/stopping the engine with engaged drive(s)	5.1.8	5.2.3
		Cutting mechanism, feed augers, reel	—	6.3
		Grain tank augers and grain handling systems	—	6.4.1; 6.4.2; 6.4.3; 6.4.4; 6.4.5.1; 6.4.6
		Maize harvesting attachment	—	6.5
		Infeed mechanism	—	7.2
		Inspection points, inspection of drum and fingers	—	8.1.2.1.2
		Basket lowering	—	8.2.1
		Compactor auger operation	—	8.2.2
A.1.6	Impact hazard	Movement of boarding means	4.5.1.2.5	5.3.5
		Movement of folding elements	4.14.5; 4.14.6	5.5
		Design of steering system	5.1.3.2	5.1.2
		Operator's seat, adjustment of suspension system	—	5.3.1.4
		Movement of cabin doors	—	5.3.12.2.1
		Interchangeable and detachable harvesting devices	—	5.6.1
		Maize picker head (covers)	—	6.5.1.1
A.1.7	Stabbing or puncture hazard	Working tools	4.7	5.1.2
A.1.8	Friction or abrasion hazard	Actuation of controls	4.4.3; 5.1.3.2	5.2.1.3; 5.2.2; 5.2.3; 5.3.3, 7.2.5
		Electrical equipment, location of cables	4.9.1	5.16.1
		Location of boarding means	4.5.1.1.2	5.3.5
A.1.9	High-pressure fluid injection or ejection hazard	Hydraulic components and fittings (e.g. rupture)	4.10; 6.5	5.15

Table 1 (continued)

No. <sup>a</sup>	Hazard	Hazardous situation and event	Clause/subclause of ISO 4254-1:2008	Clause/subclause of this part of ISO 4254
<b>A.2</b>	<b>Electrical hazards</b>			
A.2.1	Contact of persons with live parts (direct contact)	Non-insulated electrical equipment	4.9; 5.3, 6.5	5.9.2; 5.13.2; 5.16
A.2.2	Contact of persons with parts which have become live under faulty conditions (indirect contact)	Electrical equipment	4.9.1	5.13.2; 5.16
A.2.3	Approach to live parts under high voltage	Contact with overhead power lines	8.1.3, 8.2.1	5.11; 10.1.2; 10.2.3.2
A.2.4	Thermal radiation or other phenomena such as the projection of molten particles and chemical effects from short circuits, overloads, etc.	Failure of electrical equipment	4.9.2	5.1.2
		Failure of battery	5.3.1	5.9.2
<b>A.3</b>	<b>Thermal hazards</b>			
A.3.1	Burns, scalds and other injuries by possible contact of persons with objects or materials with an extreme high or low temperature, by flames or explosions and also by the radiation of heat sources	Hydraulic system, operating fluids (e.g. fuel, hydraulic oil, engine coolant)	4.12	5.9.3; 10.1.2
		Cabin material (in case of fire)	5.1.6	5.10.3
		Hot surfaces (e.g. of engine and associated parts)	5.5	5.8; 10.1.2
<b>A.4</b>	<b>Hazards generated by noise</b>			
A.4.1	Hearing loss (deafness), other physiological disorders (e.g. loss of balance, loss of awareness), accidents due to interference with speech communication and acoustic warning signals	Working of the machine	4.2; 8.1.3	5.14

Table 1 (continued)

No. <sup>a</sup>	Hazard	Hazardous situation and event	Clause/subclause of ISO 4254-1:2008	Clause/subclause of this part of ISO 4254
<b>A.5</b>	<b>Hazards generated by materials and substances</b>			
A.5.1	Hazards resulting from contact with or inhalation of harmful fluids, gases, mists, fumes and dusts	Contact with operating fluids (fuel tank, hydraulic systems, engine cooling system)	4.10; 4.12; 5.4; 8.1.3	5.9.3; 5.15; 10.1.2
		Cabin material (in case of fire)	5.1.6	5.10.3
		Battery	5.3.1	5.9.2
		Exhaust system	5.6	5.1.2
		Ventilation system	—	5.3.12.5
A.5.2	Fire or explosion hazard	Cabin material	5.1.6	5.10.3
<b>A.6</b>	<b>Hazards generated by neglecting ergonomic principles in machinery design</b>			
A.6.1	Unhealthy postures or excessive efforts	Location and design of controls	4.4; 8.1.3	5.2.1; 10.1.2; 10.2.2
		Location and design of boarding means	4.5.1; 4.6; 8.1.3	5.3.5; 5.3.6; 5.4
		Service and maintenance operations	4.14.2; 4.14.4	5.1.2
		Design of folding elements	4.14.5	5.5.3
		Design of operator's work station	5.1.1; 5.1.2.1; 5.1.3	5.3.8; 5.3.12.4
		Interchangeable and detachable harvesting devices	—	5.6
		Location of greasing points	—	5.9.6.1
A.6.2	Inadequate consideration of hand-arm or foot-leg anatomy	Location of controls	4.4	5.2.1; 5.3.3; 5.12.2; 5.13.3; 6.4.5.2; 7.2.5; 8.1.2.1; 8.2.2.1
		Design of boarding means	4.5; 4.6	5.3.5; 5.3.6; 5.3.7; 5.3.8; 5.4
		Design of operator's work station	5.1	5.3.1; 5.3.2; 5.3.4; 5.3.7; 5.3.8; 5.3.11; 5.3.12.2; 5.3.12.3; 5.3.12.4
A.6.3	Not using, wrong or neglected use of personal protective equipment	Missing or insufficient information about the use of personal protective equipment in the operator's manual	8.1.3	10.1.4.2
A.6.4	Missing or insufficient local lighting	Operation of the machine, service and maintenance operations	5.1.7.3	5.3.11.1
A.6.5	Mental overload and under load, stress	Multifunction controls	4.4	5.2
		Provisions for installing working lights	5.1.7	5.3.11.1

Table 1 (continued)

No. <sup>a</sup>	Hazard	Hazardous situation and event	Clause/subclause of ISO 4254-1:2008	Clause/subclause of this part of ISO 4254
A.6.6	Human error, human behaviour	Identification, design and location of controls	4.4	5.2
		Missing or insufficient explanation of controls and signs in the operator's manual	8.1	10.1.2
		Location and design of signs	8.2	10.2.2; 10.2.3
A.6.7	Inadequate design, location or identification of manual controls	Design, location and identification of controls	4.4; 5.1.3; 6.1.3	5.2; 5.3.3; 5.12.2; 5.13.3; 6.4.5.2; 7.2.5; 8.1.2.1; 8.2.2.1
A.7	<b>Combination of hazards</b>	Manual operation of individual assemblies	4.13	5.9.1
		Missing or insufficient information about manual operation of individual assemblies and, if required use of special tools in the operator's manual	8.1	10.1.2
<b>A.8</b>	<b>Unexpected start-up, unexpected overrun/overspeed</b>			
A.8.1	Failure/disorder of the control system	All control systems	4.8, 4.9	5.9.4, 5.13.2, 5.16
		Hydraulic, pneumatic and electrical connections	6.5	5.1.2
A.8.2	Restoration of energy supply after an interruption	All control systems	4.4; 6.1	5.1.2; 5.2; 5.3.9.1; 5.12.2; 6.4.5.2; 7.2.5; 8.1.2.1; 8.2.2.1
A.8.4	Other external influences (gravity, wind, etc.)	Stability	6.2.1.1; 6.2.1.2	5.1.2
A.8.5	Errors made by the operator (due to mismatch of machinery with human characteristics and abilities, see A.6.6 of this table)	Design and location of controls	4.4; 6.1.2	5.1.2; 5.2; 5.3.3; 5.12.2; 5.13.3; 6.4.5.2; 7.2.5; 8.1.2.1; 8.2.2.1
		Design of boarding means	4.5, 4.6	5.3.5; 5.3.6; 5.3.8; 5.4
		Design of operator's work station	5.1	5.3.1; 5.3.2; 5.3.4; 5.3.8; 5.3.11; 5.3.12.4
		Operating system	5.2	5.9.5
		Service and maintenance systems	4.14	5.1.2; 5.5.1; 5.5.2
		Mounting system of machines, interchanging system of harvesting devices	6.2; 6.3	5.1.2; 5.6
		Cutterhead drive operation	—	7.3
		Design of knife sharpening device	—	7.5
Missing or insufficient instructions in the operator's manual	8.1.3	10.1		



Table 1 (continued)

No. <sup>a</sup>	Hazard	Hazardous situation and event	Clause/subclause of ISO 4254-1:2008	Clause/subclause of this part of ISO 4254
A.9	Impossibility of stopping the machine in the best possible conditions	All control systems	4.4; 5.1.8, 6.1	5.1.2; 5.2, 5.3.9
A.10	Variations in the rotational speed of tools	PTO drive shaft	6.4	5.1.2
A.11	Failure of energy supply	Power operated mechanical supports, hydraulic locking devices	4.8	5.9.4
		All control systems	4.9; 4.10; 4.11; 4.12; 5.1.3; 5.1.8	5.1.2; 5.2.3; 5.3.9; 5.7; 5.12.2; 5.13; 5.15; 5.16.1; 6.4.5.2; 7.2.5; 8.2.2.1
A.12	Failure of the control circuit	All control systems	4.9; 4.10; 4.11; 4.12; 5.1.3; 5.1.8	5.1.2; 5.2.3; 5.3.9; 5.7; 5.12.2; 5.13; 5.15; 5.16.1; 6.4.5.2; 7.2.5; 8.2.2.1
A.13	Errors of fitting	Mounting systems of machines, interchanging systems of harvesting devices	6.2; 6.3	5.1.2; 5.6
		Missing or insufficient instructions in the operator's manual	8.1.3	10.1
A.14	Break-up (of parts) during operation	Guards and barriers (strength)	4.7	5.1.2
		Supports (strength)	4.8	5.9.4
		Hydraulic components	4.9	5.15
		Pneumatic components	4.11	5.1.2
A.15	Falling or ejected objects or fluids	Detachable supports not in storage position	4.8	5.9.4
		Rupture of hydraulic components	4.10	5.15
		Folding elements not retained in transport position	4.14.5	5.5.1
		Operation of chopper, spreader	—	6.5.2; 6.6.1.2; 6.6.5
		Operation of knife sharpening device	—	7.5.1
A.16	Overtipping of the machine	Loss of stability of the machine	6.2	5.1.2, 6.1
A.17	Slip, trip and fall of persons (related to machinery)	Design of boarding means	4.5; 4.6	5.3.5; 5.4
		Design of platforms	4.5.2	5.3.7; 6.2
		Design of locations for service and maintenance	4.6.3	5.1.2
<b>Additional hazards, hazardous situations and hazardous events due to mobility</b>				
A.18	<b>Relating to the travelling function</b>			
A.18.1	Movement when starting the engine	Activation of ground propulsion control system	5.1.3	5.2.1.3

Table 1 (continued)

No. <sup>a</sup>	Hazard	Hazardous situation and event	Clause/subclause of ISO 4254-1:2008	Clause/subclause of this part of ISO 4254
		Actuation of start/stop control system of the engine	5.1.8	5.2.3
A.18.2	Movement without a driver at the driving position	Activation of ground propulsion control system	5.1.3	5.2.1.3
		Actuation of start/stop control system of the engine	5.1.8	5.2.3
A.18.3	Movement without all parts in a safe position	Folding elements securing system	4.14.5	5.5.1
A.18.4	Inability of machinery to be slowed down, stopped and immobilized	Actuation of ground propulsion control system	5.1.3	5.2.1.3
<b>A.19</b>	<b>Linked to the work position</b>			
A.19.1	Fall of persons during access to (or at/from) the work position	Boarding means	4.5; 4.6	5.3.5; 5.3.6; 5.3.7; 5.3.8; 5.4
		Platforms	4.5.2	5.3.7; 6.2
		Locations for service and maintenance	4.6.3	5.1.2
A.19.2	Exhaust gases/lack of oxygen at the work position	Cabin	5.4.1; 5.6	5.1.2
A.19.3	Fire (flammability of the cab, lack of extinguishing means)	Cabin material (see also 7.1 and 7.2 of this table)	5.1.6	5.10.3
		Fire extinguishers	—	5.10.1; 5.10.2
A.19.4	Mechanical hazards at the working position: a) contact with wheels b) break-up of parts rotating at high speed c) rollover	Wheels	4.5.1.1.2	5.3.5
		PTO drive shaft(s)	4.6.4	5.1.2
		Shape and integrated structure of the machine	—	6.1
		Operation of chopper, spreader	—	6.5.2; 6.6
A.19.5	Insufficient visibility from the work positions	Visibility (to the front, to the rear, to the working area)	5.1.7	5.3.11
A.19.6	Inadequate lighting	Provisions for installing working lights	5.1.7	5.3.11.1
A.19.7	Inadequate seating	Operator's seat	5.1.2	5.3.1
		Instructional seat	—	5.3.2
A.19.8	Noise at work position	Working of the machine	4.2	5.14
A.19.10	Insufficient means for evacuation/emergency exit	Emergency exits of cabin	5.1.5	5.3.12.4

Table 1 (continued)

No. <sup>a</sup>	Hazard	Hazardous situation and event	Clause/subclause of ISO 4254-1:2008	Clause/subclause of this part of ISO 4254
<b>A.20</b>	<b>Due to the control system</b>			
A.20.1	Inadequate location of manual controls	All manual controls	4.4; 4.8.1.2; 5.1.2.1; 5.1.3.3; 6.1.1; 6.1.2	5.1.2; 5.2; 5.3.3; 5.12.2; 7.2.5
A.20.2	Inadequate design of manual controls and their mode of operation	All manual controls	4.4; 5.1.3; 5.1.8	5.1.2; 5.2; 5.3.1.5; 5.12; 7.2.5; 8.1.2.1; 8.2.2.1
<b>A.21</b>	<b>From handling the machine (lack of stability)</b>	Lack of stability of the machine when in operation	6.2	5.1.2
<b>A.22</b>	<b>Due to the power source and to the transmission of power</b>			
A.22.1	Hazards from the engine and the batteries	Starting/stopping the engine	5.1.8	5.2.3
		Battery	5.3	5.9.2
A.22.2	Hazards from transmission of power between machines	Power transmission between self-propelled machine/tractor to recipient machine	6.4	5.1.2
A.22.3	Hazards from coupling and towing	Mounting system of machines, interchanging system of harvesting devices	6.2.2; 6.2.3; 6.3	5.1.2; 5.6
		Missing or insufficient instructions in the operator's manual	8.1.3	10.1
<b>A.23</b>	<b>From/to third persons</b>			
A.23.1	Unauthorized start-up and use	Starting/stopping devices for the engine	5.1.8	5.2.3
A.23.3	Lack or inadequacy of visual or acoustic warning means	Visibility from the operator's work station to the front and to the rear	5.1.7	5.3.11
<b>A.24</b>	<b>Insufficient instructions for the driver/operator</b>	Missing or insufficient instructions in the operator's manual	8.1	10.1
<sup>a</sup>	With reference to ISO 4254-1:2008, Table A.1.			

## 5 Safety requirements and/or measures for all machines

### 5.1 General

**5.1.1** Machinery shall be in accordance with the safety requirements and/or protective measures of this clause. In addition, the machine shall be designed according to the principles of ISO 12100-1:2003, Clause 5, for hazards relevant, but not significant, which are not dealt with by this part of ISO 4254. For those hazards, ISO 12100-2 may be used for guidance.

**5.1.2** Except where otherwise specified in this part of ISO 4254, the machine shall be in accordance with ISO 4254-1.

### 5.2 Controls

#### 5.2.1 Location and identification of controls

**5.2.1.1** Controls such as steering wheels or steering levers, gear levers, control levers, cranks, pedals and switches shall be chosen, designed, constructed and arranged according to the following.

- a) Their locations and method of operation shall be in accordance with ISO 15077.
- b) Unless otherwise specified in this part of ISO 4254, the controls referred to in A.3.1, A.3.2 and A.3.3 shall be located within hand and foot reach of the operator in the operator's work station. The locations for all other controls shall be in accordance with ISO 15077.
- c) The controls and their different positions shall be identified [see 10.2.2 a)]. These identities shall be explained in the operator's manual [see 10.1.2 a)]. If symbols are used, they shall be in accordance with ISO 3767-1 and ISO 3767-2. If different colours for identification of controls are used, they shall be in accordance with the provisions of Annex A.

Additional requirements for specific controls are given in 5.3.3, 5.3.8, 5.3.9, 5.12, 5.13.3, 6.4.5.2, 7.2.5, 8.1.2.1 and 8.2.2.1.

**5.2.1.2** The controls, excluding the operator presence control, if fitted, shall be arranged such that in any of their positions they do not hinder access to the operator's position, and shall be located so that they cannot be used as handholds during boarding or exiting the machine excluding the steering wheel (see also 5.3.8).

**5.2.1.3** For normal operation, the controls used to activate the ground propulsion system shall be located such that they can only be actuated when being in the operator's work station. Pedals shall have an appropriate size, shape and be adequately spaced. The pedals shall have a slip-resistant surface and be easy to clean.

**5.2.1.4** Where clutch, brake and accelerator pedals have the exact same function as those of passenger vehicles, the order of location shall be the same as in the passenger vehicles.

#### 5.2.2 Control clearances

Controls requiring an actuating force  $\geq 100$  N measured at the grip shall have a minimum clearance,  $a$ , of 50 mm between their outer contours and adjacent parts. Controls requiring an actuating force of  $< 100$  N shall have a minimum clearance,  $a$ , of 25 mm (see Figure 1). Fingertip controls are excluded from these requirements, providing there is no risk of inadvertent operation of adjacent controls.

#### 5.2.3 Starting and stopping the engine

The provisions of ISO 4254-1:2008, 5.1.8, apply.

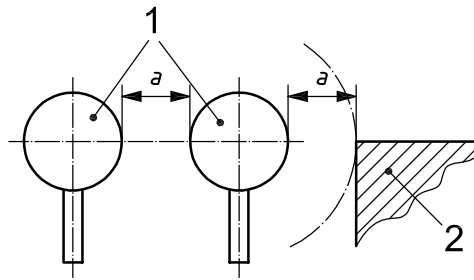
**Key**

- a* minimum clearance
- 1 manual control
- 2 adjacent part

**Figure 1 — Control clearances****5.3 Operator's work station****5.3.1 Operator's seat**

**5.3.1.1** On a machine on which the operator is required to sit, a seat shall be provided which will support the operator in all working and operating modes.

**5.3.1.2** The seat dimensions and adjustment shall meet the requirements of ISO 4253, except that the seat index point (SIP) dimension above the platform shall be 500 mm minimum and 650 mm maximum (see Figure 2).

**5.3.1.3** The seat adjustment mechanism(s) shall prevent unintended seat movement and shall have stops at the ends of the adjustment range.

**5.3.1.4** The suspension system shall be adjustable to accommodate the weight of the operator.

**5.3.1.5** The operator's manual shall provide information about the seat adjustment(s) [see 10.1.2 b)].

**5.3.1.6** Anchorage points for a restraint system in accordance with ISO 3776-1 and ISO 3776-2 shall be provided.

**5.3.2 Instructional seat**

**5.3.2.1** The instructional seat, if provided, shall meet the following requirements:

**5.3.2.1.1** The instructional seat shall be located as shown in Figure 3. The instructional seat shall be placed such that the trainer or trainee seated in it creates minimal potential impact on operation and visibility under the usage conditions specified in Clause 1, consistent with machine function and other design considerations.

**5.3.2.1.2** The instructional seat shall have the minimum dimensions shown in Figure 3. The seat shall also have a backrest of the minimum dimensions shown in Figure 3. A non-glazing component at the rear of the enclosed cabin may be used as a backrest.

**5.3.2.1.3** At least one handgrip or handrail shall be provided in a conveniently located position for the trainer or trainee while seated in the instructional seat.

**5.3.2.1.4** A suitable area, which does not interfere with the operator, shall be provided for the lower extremities of the trainer or trainee seated in the instructional seat.

5.3.2.1.5 Anchorage points for a restraint system shall be in accordance with ISO 3776-1 and ISO 3776-2.

Dimensions in millimetres

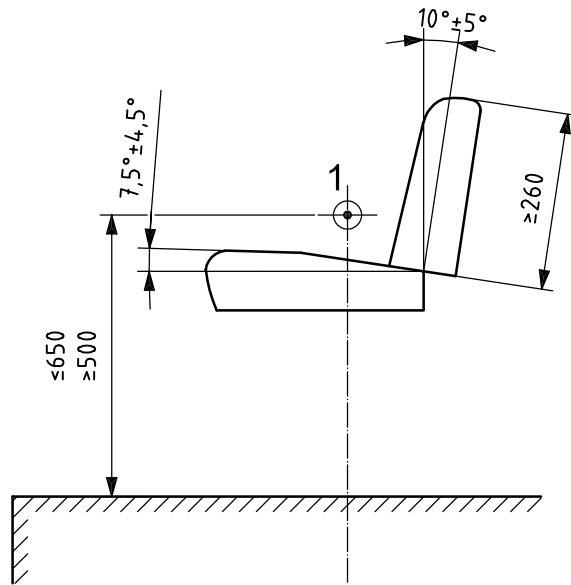

a) Intermediate seat adjustment

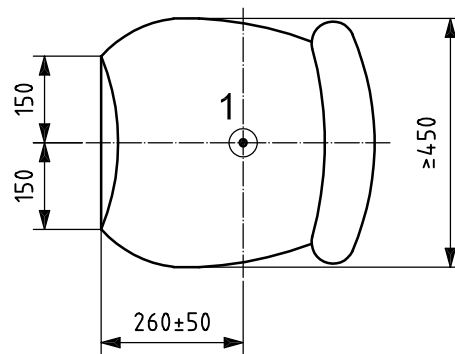

b) Coordinate for measuring width of seat

**Key**

1 SIP

**Figure 2 — Seat dimensions and height**

5.3.2.1.6 The instructional seat and the trainer or trainee seated in the instructional seat shall be inside the enclosed cabin structure.

5.3.2.1.7 The operator’s manual shall include an appropriate notice regarding the intended use of the instructional seat [see 10.1.2 c)].

**5.3.3 Steering wheel**

The centre of the steering wheel shall be on the longitudinal centreline of the seat within a maximum lateral offset (either side) of 50 mm. The clearance between the fixed parts and the steering wheel shall be in accordance with 5.3.12.3 (see Figure 7).

Dimensions in millimetres

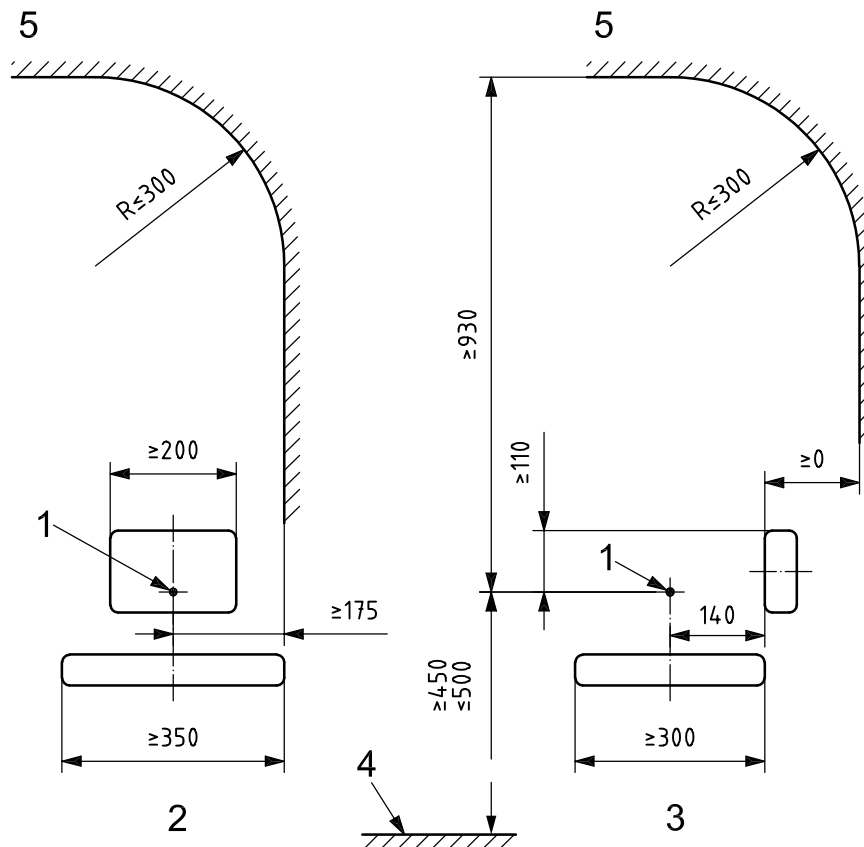

### Key

- 1 SIP
- 2 front view
- 3 side view
- 4 foot rest
- 5 clearance zone

**Figure 3 — Instructional seat dimensions**

### 5.3.4 Shearing and pinching points

**5.3.4.1** In the operator's workplace, there shall be no shearing or pinching points within hand or foot reach of the operator or occupant of the instructional seat when seated in the seat provided.

**5.3.4.2** A clearance of at least 25 mm shall be maintained between a moving seat and adjacent components.

**5.3.4.3** For machines not equipped with a cabin, hand reach is defined by a sphere of 1 000 mm radius, centred on the seat centreline, 60 mm in front of, and 580 mm above, the SIP as defined in ISO 5353. Foot reach is defined by a hemisphere of 800 mm radius centred on the seat centreline at the front edge of the cushion and extending downwards, with the seat in its central position (see Figure 4).

**5.3.4.4** For machines equipped with a cabin, hand and foot reach are defined by the portions of the sphere and hemisphere described above which are within the cabin.

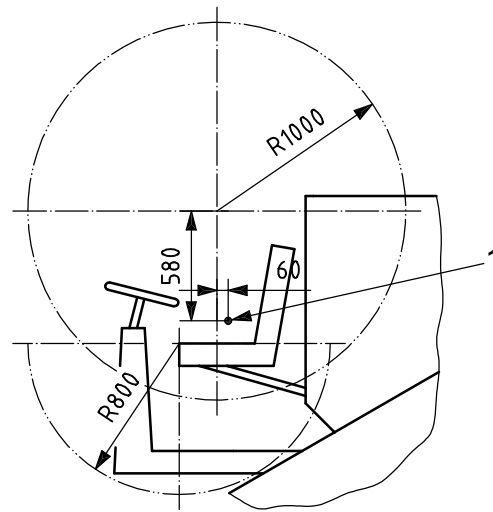

**Key**

1 SIP

NOTE For cabin-equipped machines, the cabin will limit the space defined in Figure 4.

**Figure 4 — Arm and foot reach**

**5.3.5 Boarding means**

For boarding means, the provisions of ISO 4254-1:2008, 4.5.1.1 and 4.5.1.2, apply.

**5.3.6 Handrails and handholds**

**5.3.6.1** Handrails or handholds shall be provided on both sides of the boarding means.

**5.3.6.2** These shall be so designed that the operator can maintain three-point contact at all times. The width of the handrail/handhold shall be between 25 mm and 38 mm. The lower end of the handrail/handhold shall be located not higher than 1 600 mm from the ground surface. A minimum clearance of 50 mm shall be provided for hand clearance between the handrail/handhold and the adjacent parts.

**5.3.6.3** A handrail/handhold grab shall be provided above the uppermost step/rung of the means of boarding, at a height between 850 mm and 1 100 mm. The handhold shall be at least 150 mm long.

**5.3.7 Operator platform**

**5.3.7.1** Operator platforms shall be flat and have a slip-resistant surface and, if necessary, provision for drainage.

**5.3.7.2** A platform shall be equipped with either

- a foot guard, handrail and intermediate rail around the edge of the platform with the dimensions as shown in Figure 5, or
- static machine components that afford equivalent protection to that provided by a foot guard, handrail and/or intermediate rail and which do not present other hazards, e.g. sharp edges, hot surfaces.

**5.3.7.3** The access to a platform shall be capable of being railed off if the boarding means is movable for transport. For machines equipped with a cabin, the cabin door will satisfy this requirement.



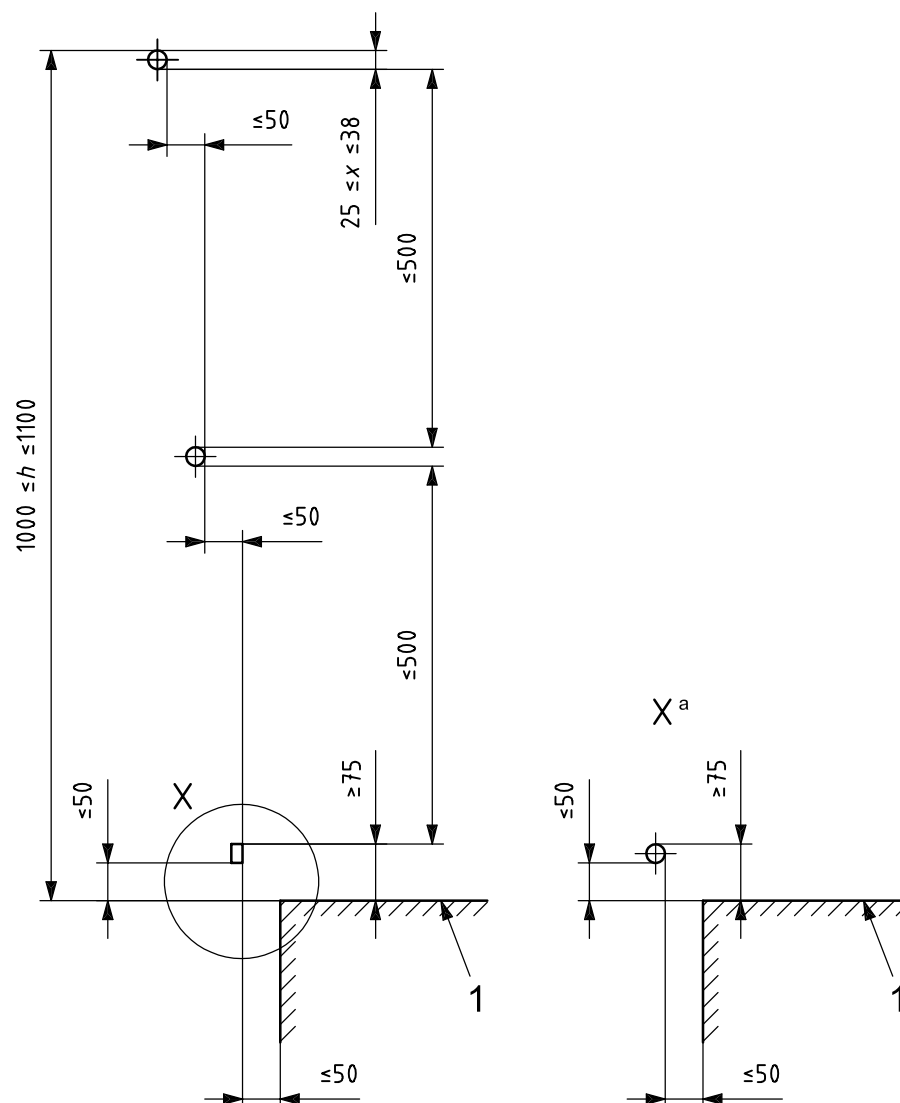

### Key

- 1 platform
- <sup>a</sup> Alternative tube-style foot guard.

**Figure 5 — Platform foot guard and handrail**

### 5.3.8 Access to operator's seat

Access to the operator's seat shall be possible by the alternate use of each foot. For this purpose, the floor area shall have a minimum width of 300 mm. Devices, including controls in any of their positions, shall be arranged such that they do not hinder access to the operator's position, except for any devices intended to restrict the operator from encountering hazards during operation.

### 5.3.9 Automatic header disengagement control

**5.3.9.1** Self-propelled machines which have an electrically activated header engagement mechanism shall have a system that prevents engagement of the header mechanism if the operator is not in the operator's work station and that automatically disengages the header mechanism when the operator leaves the operator's work station. The maximum delay time for triggering the disengagement shall be 7 s. Header

starting shall require intentional reactivation by means other than the automatic header disengagement control after stopping.

NOTE Design requirements according to ISO 13849-1 are to be added for the automatic header disengagement control at the next revision of this part of ISO 4254.

**5.3.9.2** In case of self-propelled machines with mechanically activated header engagement, the control lever for engagement shall act as an impediment for egress from the operator's seat when in the engaged position.

### **5.3.10 Warnings**

If audible or visual means are provided to inform the operator about malfunctions or a special status of the machine, for example

- grain tank extensions raised above 4 m,
- cotton basket raised,
- guidance systems activated,
- the slope compensation system in its maximum position,
- unloading auger swung out,
- knife sharpening in process,

then the information given shall be unambiguous and easily understood. The operator's manual shall provide detailed information about such means [see 10.1.2 d)].

### **5.3.11 View to front and rear**

**5.3.11.1** For the view to the front and to the rear, the provisions of ISO 4254-1:2008, 5.1.7, apply.

**5.3.11.2** Machines shall be equipped with at least two rear-view mirrors, one on each side of the machine.

**5.3.11.3** Instructions on how to clean the windscreen and to adjust the rear-view mirrors shall be provided in the operator's manual [see 10.1.2 e) and f)].

**5.3.11.4** These mirrors shall be adjustable while at the same time maintaining three-point contact if the adjustment cannot be made remotely. The mirrors shall be capable of being adjusted to provide a clear image of the total height of the rear-most section of the machine from the operator's work station.

**5.3.11.5** If it is not possible to see the area just behind the machine from the operator's seat position, an audible reverse warning alarm, which shall be automatically engaged and in accordance with ISO 9533, shall be provided.

**5.3.11.6** If a cabin is provided, provisions to install devices for defrosting and demisting the front window(s) shall be made.

### **5.3.12 Cabins**

#### **5.3.12.1 General**

When the operator's work station is equipped with a cabin, it shall meet the following requirements.

### 5.3.12.2 Doors and door openings

**5.3.12.2.1** The door opening shall conform to Figure 6 provided that the angles between the lower horizontal limitation (dimension  $\geq 300$  mm) and the lateral vertical limitations shall not be smaller than  $90^\circ$ . The dimension shown in Figure 6 shall be the aperture measured with the door open. It shall be possible for the door to remain in the open position (gas struts, effect of gravity or by mechanical means, etc.).

**5.3.12.2.2** Opening and closing the door shall be possible from the ground/platform or while keeping three-point contact with the boarding means.

Dimensions in millimetres

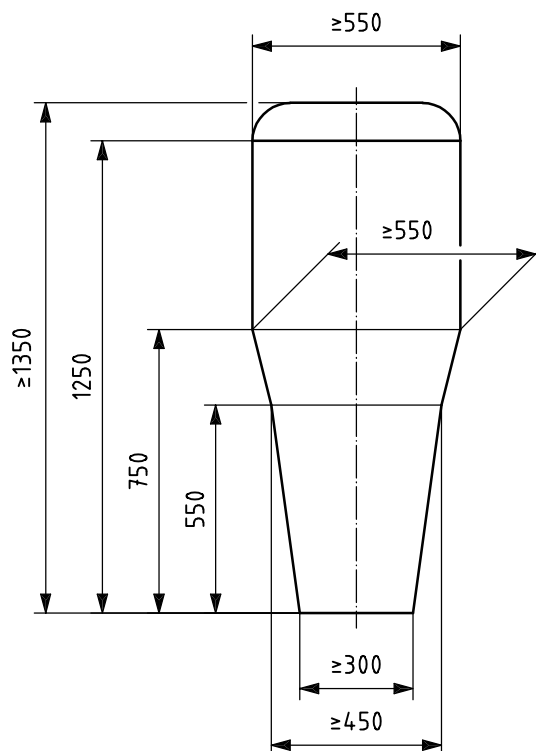

Figure 6 — Main dimensions of door opening

### 5.3.12.3 Interior dimensions

The interior dimensions shall be as shown in Figure 7. The dimensions specified apply when the seat is at the SIP position as defined in ISO 5353.

### 5.3.12.4 Emergency exits

For emergency exits, the provisions of ISO 4254-1:2008, 5.1.5, apply.

### 5.3.12.5 Ventilation

The cabin shall be equipped with a ventilation system providing an over pressure of 50 Pa. The ventilation system shall be able to filter the incoming air. Information about the selection of the air filter, its cleaning and replacement intervals shall be given in the operator's manual [see 10.1.2 g)].

Dimensions in millimetres

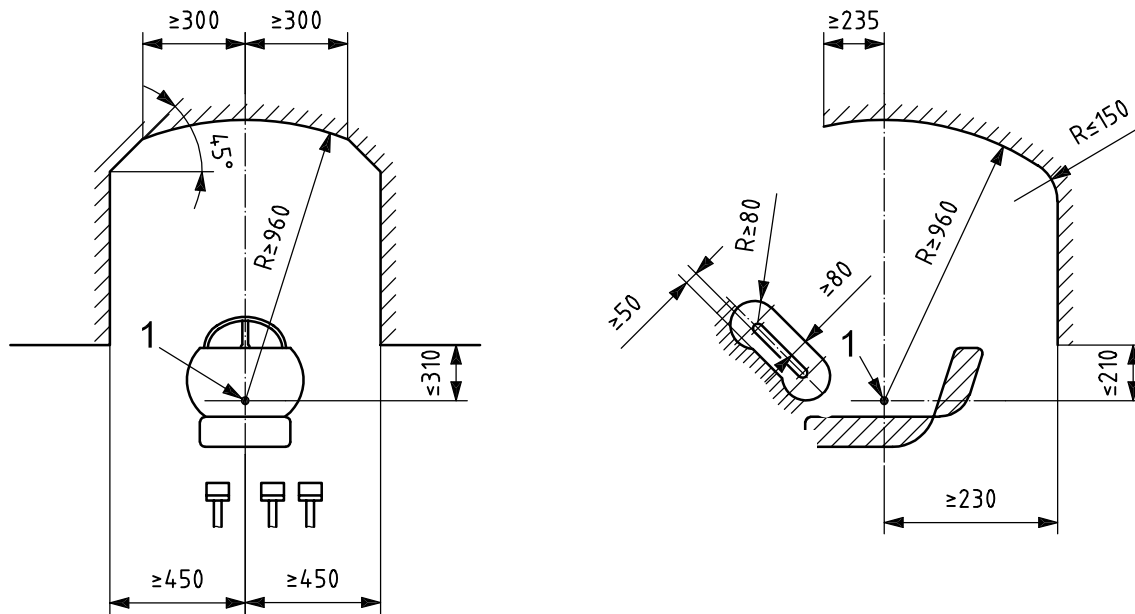

**Key**

1 SIP

**Figure 7 — Interior dimensions**

**5.4 Boarding means for other than operator’s work station**

**5.4.1** Boarding means to locations other than the operator’s work station (e.g. leading to servicing or maintenance locations) shall be provided with foot supports (e.g. rungs or steps) and handholds when the floor of the location other than the operator’s work station is located more than 550 mm above the ground or a platform.

Handholds and boarding means may be an integral part of the machine, provided they are suitably constructed and positioned.

**5.4.2** Such boarding means shall comprise a series of successive steps as shown in Figure 8 and according to one or another of the following alternatives.

- The inclination,  $\alpha$ , shall be between 70° and 90° from the horizontal (see Figure 8). Each step shall have a slip-resistant surface, a lateral stop at each end and be so designed that accumulation of mud and snow is minimized under normal conditions of work. The vertical and horizontal distances between successive steps shall be uniform within a tolerance of  $\pm 20$  mm.
- Alternatively, the boarding means shall be designed as a ladder. The top side of each rung shall have a horizontal slip-resistant surface at least 30 mm from front to back. If rungs can be used as handholds, then rectangular section rungs shall have corner radii  $\geq 5$  mm.
- Alternatively, the boarding means shall be in accordance with 5.3.5.

**5.4.3** For rice harvesters, tracked harvesters or machines with slope compensation, the height of the first step may exceed 550 mm but shall not exceed 700 mm, except for the access to the engine compartment, for which the height of the first step shall not exceed 550 mm.

**5.4.4** Handholds, handrails allowing three-point contact, guard rails or barrier type protection shall be provided to minimize the risk of falling during normal operation and service, unless the same level of

protection is provided by other parts of the machine. For cleaning of the windscreens of combine harvesters (see 6.2).

**5.4.5** Servicing or maintenance locations shall be sized for the placement of both feet and shall have slip-resistant surfaces.

**5.4.6** For access into the grain tank, see 6.4.2.

Dimensions in millimetres

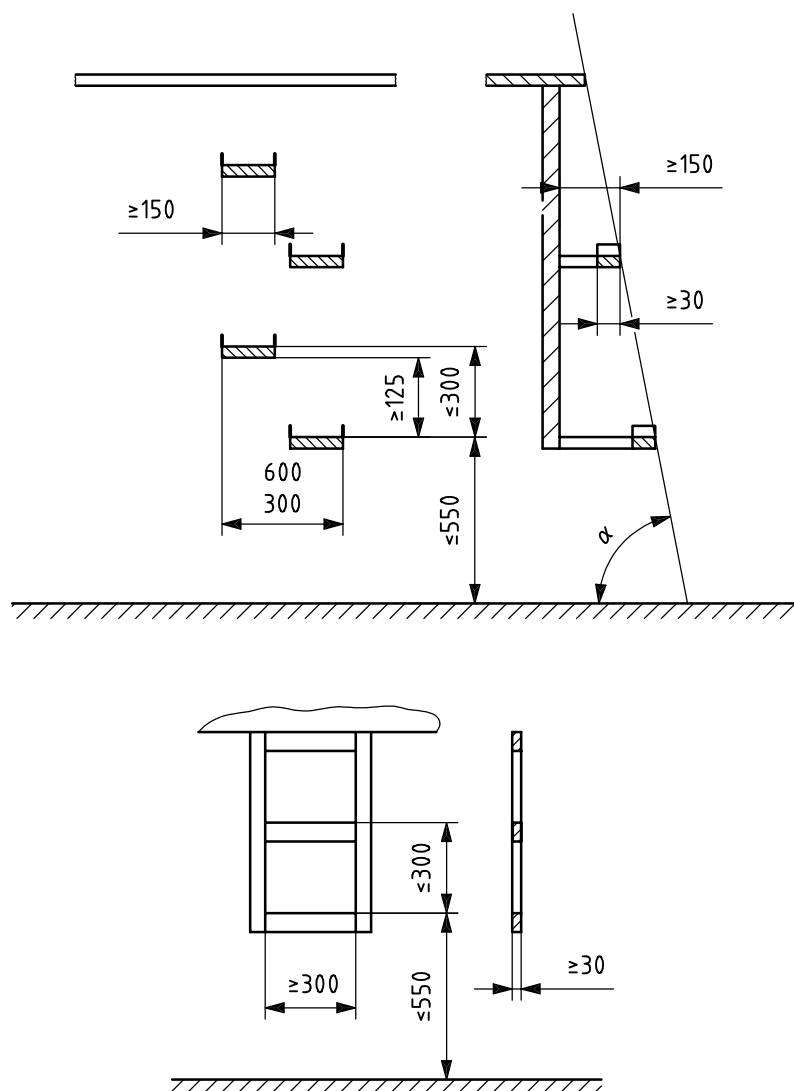

### Key

$\alpha$  angle of inclination from the horizontal

**Figure 8 — Boarding means for other than operator's work station**

## 5.5 Folding elements

**5.5.1** Folding elements to reduce transport width and/or height shall have a means of retaining in the transport position, either mechanically or by other means (e.g. hydraulically). The change from transport position to working position and vice versa shall be possible without exposing the operator to crushing and pinching.

**5.5.2** For reduction of transport width, guards of working tools as dealt with in this part of ISO 4254 may be folded from the functional/protection to a transport position. These working tools shall not be operable with the guards in transport position.

**5.5.3** Handle(s), located at least 300 mm from the nearest articulation, shall be provided for manually folded elements. The force required for the manual folding operation shall not exceed 250 N as the average value when moving from the start to the stop position. The peak(s) shall not exceed 400 N. There shall be no shearing, pinching or uncontrollable movement hazards to the operator. The handle(s) may be integral parts of the machine, provided they are suitably designed and clearly identified [see 10.2.2 b)].

## **5.6 Interchangeable and detachable harvesting devices**

**5.6.1** The interchangeable and detachable (e.g. for transport) harvesting devices (e.g. the header or the pick-up and stripping heads) shall be so designed that they can be attached, detached and loaded on and unloaded from a transport trailer by one operator. Means shall be provided for retaining these devices on the transport trailer.

**5.6.2** Mechanical drives shall be designed and constructed so that they do not constitute any hazard zones when the attachments are dismounted. The interface between the mechanical drive and the attachment shall be designed so that incorrect mounting is not possible.

**5.6.3** If the machine is equipped with a coupling device, this device shall be designed and mounted such that the coupling action is possible by one operator.

## **5.7 Automatic guidance systems**

When provided, automatic guidance systems shall

- offer a manual override capability that will disable the guidance system when the steering wheel is turned by the operator,
- give an indication of when the system is active and operational [see 10.2.2 c)],
- remain active only while the operator is present in the operator's work station,
- provide an audible warning when the system is activated but does not perform its intended function, e.g. loss of signal, and
- be explained in the operator's manual [see 10.1.2 h)].

## **5.8 Hot surfaces**

Hot surfaces which can be reached by the operator during normal operation of the machine with the exclusion of servicing, maintenance and repair shall be covered or insulated. Covering and insulation applies to hot surfaces which are near to steps, handrails, handholds, working areas and integral machine parts used as boarding means and which may be inadvertently touched. Warning shall be included in the operator's manual regarding the hot surfaces of the engine and associated parts [see 10.1.2 i)].

## **5.9 Service and maintenance**

### **5.9.1 Manual operation of individual assemblies**

If special tools are required for manual operation, e.g. turning the threshing mechanism of a combine harvester, they shall be supplied with the machine; provision shall be made for storage on the machine and their use shall be explained in the operator's manual [see 10.1.2 j)].

## 5.9.2 Battery

For the battery, the provisions of ISO 4254-1:2008, 5.3, apply.

## 5.9.3 Operating fluids

**5.9.3.1** Provisions shall be made for the safe filling, draining and collection of operating fluids such as engine oil, hydraulic fluids and coolants. Filler necks for fuel shall be located at a height of not more than 1500 mm from the ground surface or from a platform and shall be located such that spilled fuel contact with hot surfaces is avoided. Engine and hydraulic oil drainage points shall be arranged such that fluids can be drained in an appropriate common container.

**5.9.3.2** Specific instructions for changing of operating fluids, including safety aspects, shall be given in the operator's manual [see 10.1.2 k)].

## 5.9.4 Supports for service and maintenance of raised machine parts

**5.9.4.1** When it is necessary for the operator to work under raised parts of the machine in order to carry out maintenance or servicing as prescribed in the operator's manual, mechanical supports or other locking devices resulting in an equal level of protection shall be provided to prevent inadvertent lowering. Detachable mechanical supports shall have a dedicated storage position on the machine.

**5.9.4.2** Mechanical supporting devices shall withstand a load of 1,5 times the maximum load to be supported.

**5.9.4.3** If hydraulic locking devices are used, then the device shall be provided on the hydraulic cylinder or in the lines to the hydraulic cylinder. In the latter case, the lines shall be designed to withstand a pressure at least four times the maximum working pressure of that hydraulic system.

**5.9.4.4** Mechanical supports and hydraulic locking devices shall be identified by use of a colour that contrasts with the overall machine colour [see 10.2.2 d)] or by a safety sign [see 10.2.3.2 a)] located either on the device itself or in close proximity to the device.

**5.9.4.5** Specific instructions shall be contained in the operator's manual [see 10.1.2 l)].

## 5.9.5 Tie-down and jacking points

**5.9.5.1** Tie-down and jacking points shall be provided. Appropriate machine parts may also be used for these purposes. The points shall be marked and their location and procedure for use shall be described in the operator's manual [see 10.1.2 m) and 10.2.2 e)].

**5.9.5.2** For the use of lifting jacks, the provisions of ISO 4254-1:2008, 5.2.3, apply.

## 5.9.6 Greasing

**5.9.6.1** As far as possible, greasing points shall be centralized. The manufacturer shall specify in the operator's manual those parts which need to be greased or lubricated. Where parts need to be greased or lubricated while in motion, then the greasing/lubrication points shall be located outside of the hazard zone.

**5.9.6.2** Specific instructions about greasing and lubrication shall be provided in the operator's manual [see 10.1.2 n)].

## 5.10 Fire hazard

**5.10.1** Provision shall be made for the attachment of portable fire extinguishers located near the operator's work station.

**5.10.2** The manufacturer shall give in the operator's manual recommendations about the number, type and location of the fire extinguishers. If only one fire extinguisher is specified, then the recommendation shall be that it be located near the operator's work station and that it contain at least 6 kg of extinguishing agent [see 10.1.2 o)].

NOTE Concerning the type of extinguisher and classification of fires, national regulations or codes can apply.

**5.10.3** For cabin interior material, the provisions of ISO 4254-1:2008, 5.1.6, apply.

## **5.11 Overhead power lines**

**5.11.1** A safety sign shall be provided on the machine to inform of the risk of possible overhead power line contact when the machine exceeds 4,00 m in height during any mode of operation [see 10.2.3.2 b)].

**5.11.2** A suitable safety message warning of the hazard of contact with overhead power lines shall be included in the operator's manual [see 10.1.2 p)].

## **5.12 Header drive**

**5.12.1** All drives associated with the main header drive shall be disengaged by the same control and together with the main header drive.

**5.12.2** The control for the header drive shall be designed, positioned or guarded such that the risk of unintentional activation from the off or neutral position is avoided. For single-hand controls, two separate actions are required, for example, a push and hold control, a switch that requires a secondary motion, a switch that requires the combined action of thumb and fingers, a switch guard, etc.

## **5.13 Header/feeding elements drive reverser**

**5.13.1** In order to minimize associated functional hazards which can occur when removing blockages in the header and feeding elements, a drive reverser shall be provided.

**5.13.2** If this drive reverser is an electrical device, the circuits, including the supply terminals, shall be protected against intentional short circuiting.

**5.13.3** It shall not be possible to operate the reverser controls while within reach of moving components on the header.

## **5.14 Noise**

**5.14.1** For noise, the provisions of ISO 4254-1:2008, 4.2, apply.

NOTE Specific provisions for noise reduction are to be added at the next revision of this part of ISO 4254.

**5.14.2** For the determination of noise emission values, the noise test code given in ISO 4254-1:2008, Annex B, together with Annex B of this part of ISO 4254, shall be used.

**5.14.3** For machines equipped with a cabin, the operator's manual shall include a recommendation to operate the machine with all the doors and windows closed [see 10.1.2 q)].

## **5.15 Hydraulic components and fittings**

For hydraulic components and fittings, the provisions of ISO 4254-1:2008, 4.10, apply.

## **5.16 Electric equipment**

**5.16.1** For electrical equipment the provisions of ISO 4254-1:2008, 4.9, apply.



**5.16.2** For additional requirements for electrical drive reversers of header and feeding elements, see 5.13.2.

## 6 Additional requirements for combine harvesters

### 6.1 General

In case of rollover of a self-propelled combine harvester, the protection of the operator is considered sufficient if the design of the machine (shape and integrated structure, or cabin in combination with or without the structure), in combination with anchorage points for a restraining device, gives sufficient space for survival.

### 6.2 Cabin

Where a combine harvester is equipped with a cabin, means shall be provided to enable the operator to clean the windscreen from the outside while maintaining three-point contact. The requirements of ISO 4254-1:2008, 4.6.3, apply.

### 6.3 Cutting mechanism, feed augers, reel

**6.3.1** Between the outer components of the reel and adjacent fixtures, a clearance of at least 25 mm shall be maintained, provided the presence of a shield does not cause a collection of crop debris.

**6.3.2** In the operator's manual as well as on the machine, reference shall be made to function-related shearing and pinching regions of the gathering and/or cutting mechanisms such as reel arms, reel, cutting table, vertical cutter bar, cutter bar, pick-up attachment, crop lifters [see 10.1.3 a) and 10.2.3.2 c)].

**6.3.3** If there are shearing and pinching points outside the cutting table side panels caused by the cutter bar or its drive mechanism, they shall be protected from inadvertent contact by guards to the extent that the guards do not affect the performance of the machine or cause a collection of crop debris. A safety sign shall be provided on the machine [see 10.2.3.2 d)].

### 6.4 Grain tank and grain handling systems

#### 6.4.1 Grain tank design

**6.4.1.1** The grain tank shall be self-emptying so as to avoid the need to enter the grain tank during the unloading process.

**6.4.1.2** Drawing of grain samples and observing of the grain level shall be possible from outside the grain tank and from a non-hazardous position.

**6.4.1.3** The grain tank shall be designed so that the need to enter the grain tank (e.g. raising extensions, opening covers, raising the grain tank filling auger) is minimized. Where possible, these actions shall be possible from outside the grain tank. If parts or components have to be raised or lowered manually, the required force shall not exceed 400 N.

#### 6.4.2 Access into the grain tank

**6.4.2.1** If entry into the grain tank is required to perform certain actions to start the harvesting or to carry out other actions that must be performed, such as for service, maintenance or adjustment purposes, the operator's manual shall provide instructions for safe access [see 10.1.3b)].

In order to allow safe access into the grain tank, means shall be provided such as foot supports and handholds, which may be a structural part of the machine, provided they are suitably constructed and positioned and are slip-resistant.

**NOTE** Requirements for cleaning of the grain tank are under study.

**6.4.3 Distribution auger**

If the grain tank is equipped with an open distribution auger, it shall be protected against unintentional contact. This requirement shall be deemed to be fulfilled if distribution augers are provided with a cover, which prevents direct access from the driver’s work station or from other working positions and which is either

- rigidly mounted, swivelling or sliding, in the protection position during operation, and which has apertures measuring 80 mm by 80 mm maximum, provided the apertures are spaced at least 100 mm from the auger circumference within the direct reach zone and at least 50 mm in the remaining reach zone (see Figure 9), or
- at least 850 mm from the outer edge of the grain tank at the operator’s work station or other working positions, or
- during normal operation, is made inaccessible by a fixed part of the combine harvester or, if equipped with a cabin, the rear side of the cabin.

Dimensions in millimetres

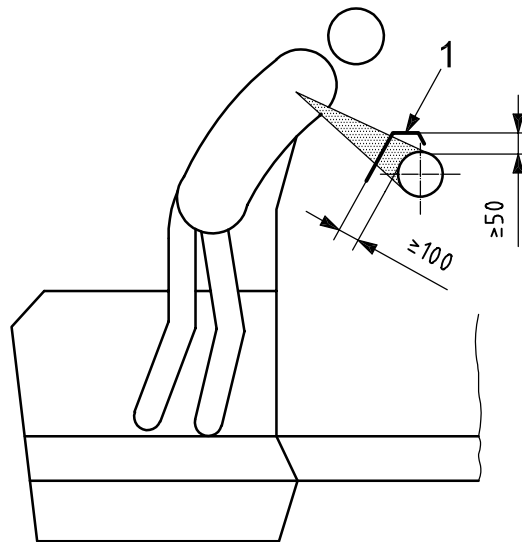

**Key**

- 1 guard

**Figure 9 — Prevention of access to distribution auger**

**6.4.4 Filling auger**

If the grain tank is equipped with an enclosed central filling auger, the minimum distance between the auger circumference and the outer edge of the grain tank at the operator’s work station or other working positions shall be

- 550 mm, if the auger flight ends at least 100 mm deep in the auger tube,
- 850 mm, if the auger flight ends less than 100 mm deep in the auger tube or the auger flight extends beyond the enclosed tube.

## 6.4.5 Discharge auger

### 6.4.5.1 General

Inside the grain tank, the discharge auger(s) shall be protected against inadvertent contact of the operator by a cover over its length.

### 6.4.5.2 Automatic discharge auger disengagement control

**6.4.5.2.1** Self-propelled combine harvesters which have an electrically activated discharge auger engagement mechanism shall have a system that prevents engagement of that mechanism if the operator is not in the operator's work station and which automatically disengages the discharge auger mechanism

- when the operator enters the grain tank through the normal means provided for grain tank entry, or
- when the operator leaves the operator's work station.

The maximum delay time for triggering the disengagement shall be 7 s.

**6.4.5.2.2** The automatic disengagement system shall apply when the combine harvester is stationary and is not required when the combine harvester is travelling.

NOTE Design requirements according to ISO 13849-1 will be added for the automatic discharge auger disengagement control at the next revision of this part of ISO 4254.

**6.4.5.2.3** For self-propelled combine harvesters with a mechanically activated discharge auger engagement, the control lever for engagement shall act as an impediment for egress from the operator's seat when in the engaged position or shall be designed as a hold-to-run lever.

## 6.4.6 Clean grain and returns handling systems

Access to the moving parts of the clean grain and returns handling systems (elevator flights and augers), through clean-out openings, do not require the use of tools. Information shall be provided in the operator's manual regarding cleaning of the clean grain and returns handling systems [see 10.1.3 c)].

## 6.5 Maize harvesting attachment

### 6.5.1 Maize picker head

**6.5.1.1** Upwardly swivelling covers shall be self-supporting and held in the opened position.

**6.5.1.2** Information shall be provided in the operator's manual and on the machine regarding residual risks of shearing and pinching on a feeding mechanism which cannot be guarded for functional reasons (e.g. working components, rotary crop divider [see 10.1.3 d) and 10.2.3.2 e]).

### 6.5.2 Mid-mounted choppers

#### 6.5.2.1 Horizontal axis

The distance between rotating working tools (e.g. knives) and the outer edge of the picking device or the guard shall be at least 150 mm at a height of 300 mm maximum. The lateral ends of the mid-mounted chopper shall be covered and the cover shall extend to at least 3 mm beyond the tip-path of the working tools (see Figure 10).

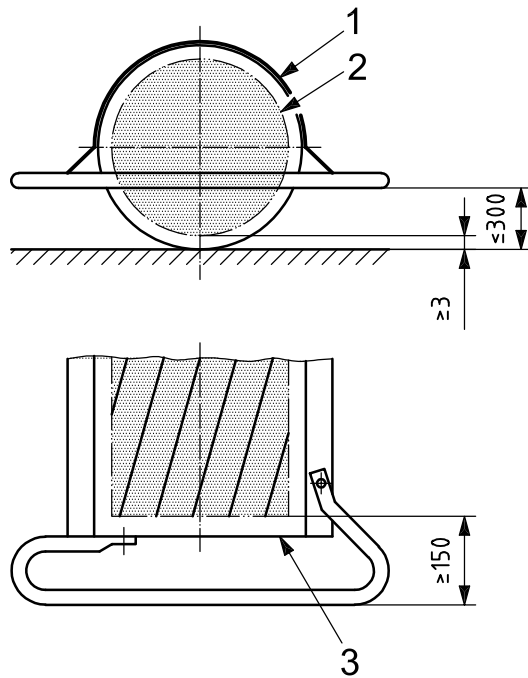

**Key**

- 1 guard
- 2 tip circle of tool
- 3 guard (front)

**Figure 10 — Mid-mounted chopper with horizontal arrangement of working tools**

**6.5.2.2 Vertical axis**

**6.5.2.2.1** The safety distance between rotating working tools (e.g. knives) and a rear-fixed closed barrier shall be at least 300 mm at a maximum height of 150 mm above the plane of the path of the tools (see Figure 11).

**6.5.2.2.2** At the sides, a fixed closed guard shall extend at least 10 mm below the path of the tools.

**6.5.2.2.3** A protective device at the rear shall avoid ejected chopped material creating a hazard for exposed persons.

**NOTE** Materials to be considered are, for example, canvas, rigid imperforate guard, chains or rubber strips.

Dimensions in millimetres

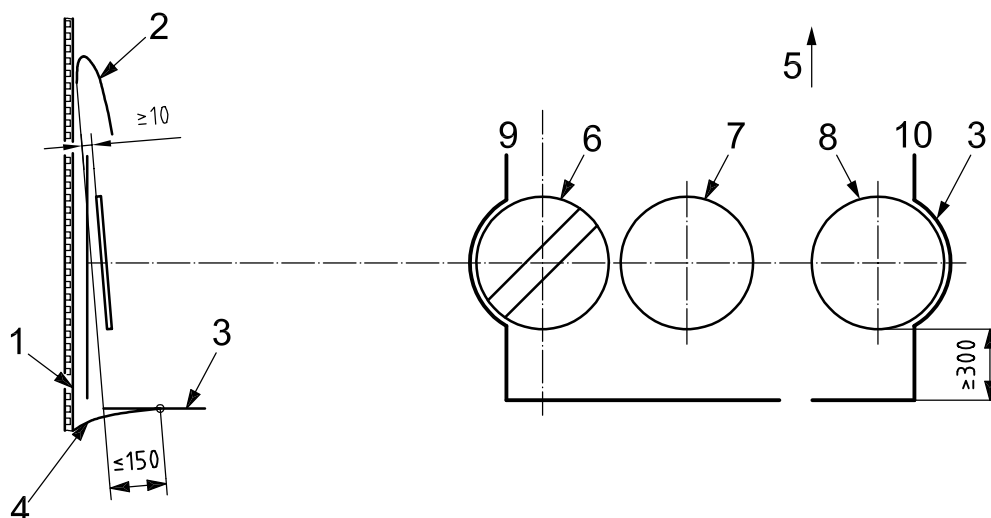
**Key**

- 1 field
- 2 crop gathering tools
- 3 fixed enclosed guard
- 4 rubber canvas
- 5 driving direction
- 6 tip circle of tool, row 1
- 7 tip circle of tool, row 2
- 8 tip circle of tool, row *n*
- 9 left hand
- 10 right hand

**Figure 11 — Mid-mounted chopper with vertical arrangement of working tools**

## 6.6 Rear straw chopper, straw spreader and chaff spreader

### 6.6.1 General

**6.6.1.1** The straw chopper, straw spreader or chaff spreader shall disengage simultaneously with the threshing mechanism.

**6.6.1.2** A safety sign or safety signs shall be provided near the chopper and/or the spreader to draw attention to the possibility of working parts running on (where this condition exists) and to the residual risks of thrown objects [see 10.1.3 e) and f), and 10.2.3.2 f) and g)].

### 6.6.2 Straw chopper with discharge chute

**6.6.2.1** Guarding of moving parts of the straw chopper shall be provided similar to the examples shown in Figure 12 a) and b). This may be accomplished by a combination of barriers and fixed parts of the machine. The projection of these guards on a horizontal plane shall be continuous.

**6.6.2.2** When the straw chopper is in the operating position, these guards shall be positioned

- at least 850 mm behind the tip path of the knives, or 550 mm if the lower edge of the guard is less than 1100 mm above the ground level, and

— at least 550 mm from the sides of the tip path of the knives at a maximum height of 1 100 mm above ground level (this guard is not required if the sides of the chopper housing or other machine part extends at least 230 mm beyond the tip path of the knives).

**6.6.2.3** Straw choppers with the facility of folding to the guards in order to reduce transport width to allow travel and/or operation of a combine harvester without the straw chopper being in operation shall be designed such that normal operation of the straw chopper is prevented when the guards are in the folded position (e.g. blocking the discharge chute). It shall be possible to fold the guards without using a tool.

**6.6.2.4** If the straw chopper knives cannot be disengaged when the straw chopper is in the windrow position, the guarding requirements for the straw chopper operating position apply.

Dimensions in millimetres

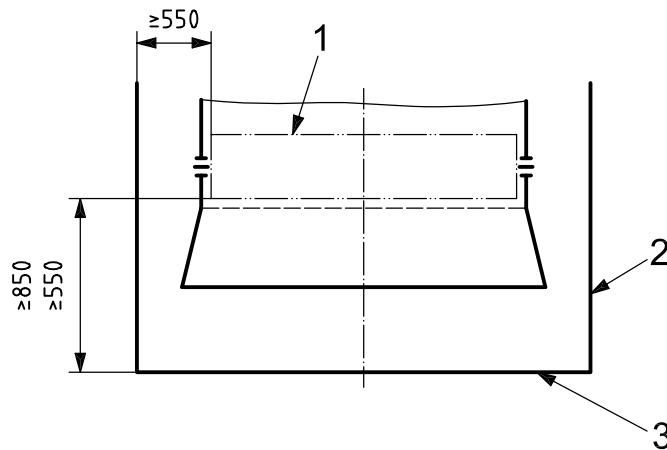

a) Guard

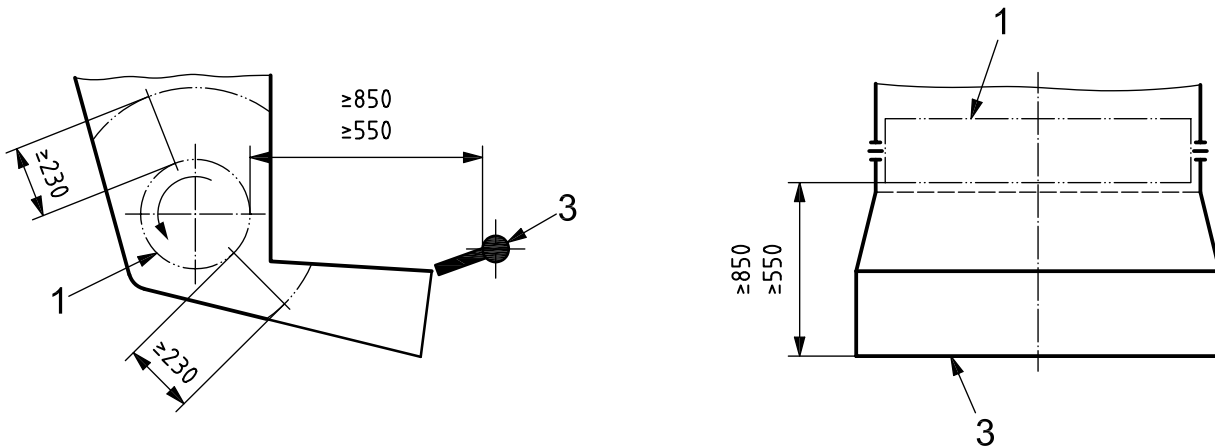

b) Side guarding

**Key**

- 1 tip path of knives
- 2 side barrier
- 3 rear barrier

**Figure 12 — Guarding for straw choppers with discharge chute**

### 6.6.3 Straw chopper with driven spreader

**6.6.3.1** Guarding of the straw chopper itself shall be in accordance with 6.6.2.

**6.6.3.2** Moving parts of the driven spreader shall be equipped with guards to protect the operator from inadvertent contact. This requirement may also be fulfilled by a combination of guards and barriers or other rigid machine parts providing at least an equal level of safety.

**6.6.3.3** When the spreader is in the operating position, these guards shall be positioned at least 550 mm from the outer edges of the driven working tools in the zone of the discharge apertures at a maximum height of 1 100 mm above ground level.

**6.6.3.4** If the spreader is open at the top or bottom for functional reasons, a guard to prevent inadvertent contact shall be mounted at the sides with a dimension extending at least 230 mm above/below the working tools, except in the outlet area (see Figure 13).

Dimensions in millimetres



Figure 13 — Driven spreader guard

### 6.6.4 Chaff spreader

**6.6.4.1** Moving parts of the chaff spreader shall be guarded to protect the operator from inadvertent contact. This requirement may also be fulfilled by a combination of guards and barriers or other rigid machine parts providing at least an equal level of safety.

**6.6.4.2** When the spreader is in the operating position guards, barriers and rigid machine parts used for safeguarding shall be positioned

- at least 850 mm from the outer edges of the driven working tools if the lower edge of the guard is greater than or equal to 1 100 mm above ground level, or
- at least 550 mm from the outer edges of the driven working tools if the lower edge of the guard is less than 1 100 mm above ground level.

### 6.6.5 Straw spreader

A safety sign warning against the hazard from thrown objects shall be provided near the discharge chute [see 10.2.3.2 g)]. Reference to this shall be included in the operator's manual [see 10.1.3 f)].

## 6.7 Stone trap

It shall be possible to empty the stone trap without the need to go under the combine harvester.

## 6.8 Storage of sickle bars

Means shall be provided for safe storage of a replacement sickle bar on the sickle bar header.

## 7 Additional requirements for forage harvesters

### 7.1 Operator's work station

When the operator's work station is equipped with a cabin, a windscreen washer shall be provided.

### 7.2 Infeed mechanism

7.2.1 Shearing and pinching points shall be avoided or guarded where this is functionally possible.

7.2.2 In order to protect exposed persons against unintentional contact with any accessible moving parts at the front and sides of the pick-up devices, a barrier (e.g. a bar) shall be fitted. This requirement is also fulfilled by a combination of guards and barriers or other rigid machine parts providing at least an equal level of safety.

7.2.3 In the working position, this barrier shall be

- a minimum of 230 mm in front of the most forward point of the tine path and at a height of between 500 mm and 1 000 mm above the ground, and
- a minimum of 150 mm from the sides of the tine path at a height of between 500 mm and 1 000 mm above the ground.

When a bar, or some other part of the machine, is also used then it shall be located at a height of between 500 mm and 1 000 mm above the ground (see Figure 14).

7.2.4 The requirement of guarding the side of the tine path is also fulfilled where guards or fixed parts of the machine have at least the same dimension as the area covered by the tine tip path.

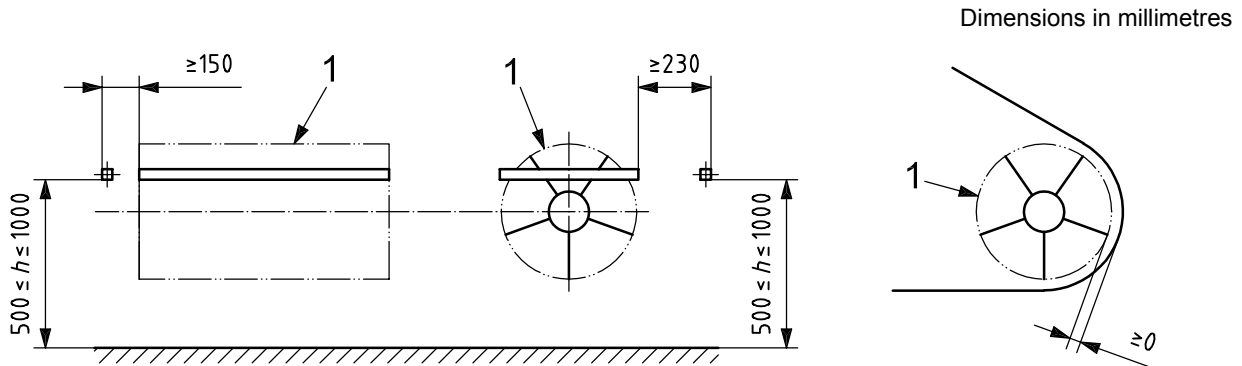

#### Key

- 1 tine path of tools

Figure 14 — Rotating pick-up device



**7.2.5** If the forage harvester is equipped with an additional control for the reverser drive outside the operator's work station (see Figure 15), this additional control shall

- be a hold-to-run control, and
- have only the reverse and stop function, and
- be located at the side of the machine (left or right side) in such a way, that the operator can only actuate the control when
  - 1) standing on the ground, and
  - 2) he has an adequate direct visibility on the reverser work area, and
  - 3) the distance between the control and the front edge of the feed roller housing is at least 850 mm.

Dimensions in millimetres

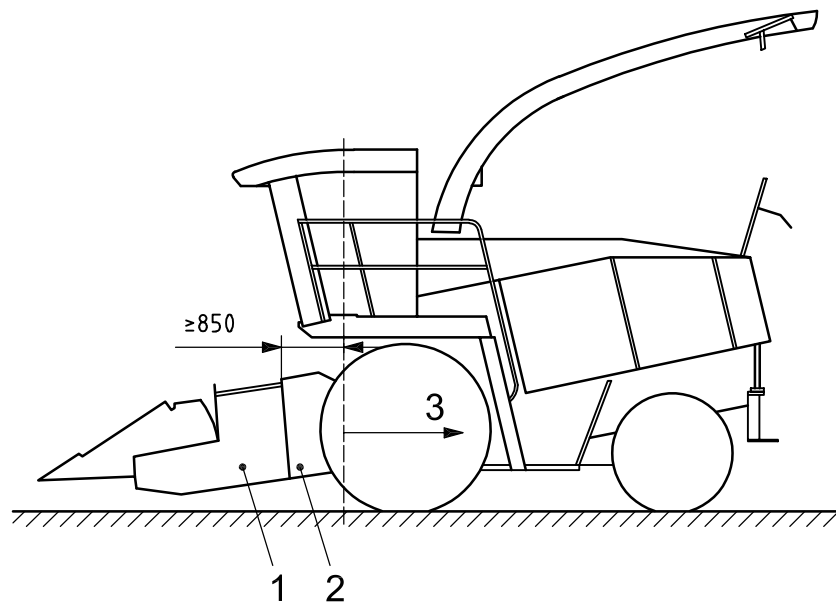

#### Key

- 1 header
- 2 feeder housing
- 3 area for the additional control behind this line

**Figure 15 — Additional control for reverser drive**

**7.2.6** Information shall be provided in the operator's manual and by safety signs on the forage harvester regarding shearing and pinching regions of the gathering and cutting mechanism, such as cutterbar, pickup attachment and row crop gatherers [see 10.1.4.1 a) and 10.2.3.2 c)]. If there are shearing and pinching points outside the function-related areas, they shall be protected.

**7.2.7** Where forage harvesters are equipped with the combine harvester headers, 6.5.1 applies.

### 7.3 Cutterhead drive

It shall not be possible to engage the infeed drive before engaging the cutterhead drive.

## 7.4 Alarm for run-down of cutterhead and blower

**7.4.1** If the run-down time of the cutterhead and blower exceeds 10 s, an audible alarm shall be provided to warn of cutterhead and blower run-down after the cutterhead drive has been disengaged or the engine has been shut off.

**7.4.2** The alarm shall be activated if the operator leaves the operator's work station and shall continue to sound until the cutterhead and blower have come to a complete stop.

**7.4.3** The alarm shall be outside the cabin and function regardless of whether or not the engine is running.

NOTE Design requirements according to ISO 13849-1 are to be added for the alarm for run-down of cutterhead and blower at the next revision of this part of ISO 4254.

## 7.5 Knife sharpening device

**7.5.1** Knife sharpening and adjustment of the shear bar, either automatic or manual, shall be possible with all guards which are protecting the cutterhead remaining in place.

**7.5.2** However, if it is necessary on trailed forage harvesters with manual shear bar adjustment to visually check and adjust the knife to shear bar clearance with a stationary cutterhead, it shall be possible to rotate the cutterhead manually, without the need to touch the knives.

**7.5.3** Specific instruction shall be provided in the operator's manual [see 10.1.4.1 b)].

## 8 Additional requirements for cotton harvesters

### 8.1 Harvest mechanism, feed augers, reel

#### 8.1.1 Cotton stripper and cotton picker

Information shall be provided in the operator's manual and on the machine regarding function-related shearing and pinching regions of the gathering mechanisms [see 10.1.5 a) and 10.2.3.2 c)].

#### 8.1.2 Cotton picker only

##### 8.1.2.1 Drums

**8.1.2.1.1** The requirements of 5.3.9.1 apply to engagement and disengagement of the cotton picker drums.

**8.1.2.1.2** For inspection and lubrication of drum and fingers, a remote hold-to-run control that requires continuous actuation in order to maintain drum rotation shall be provided on a tether of sufficient length to allow the operator to inspect each drum with the remote control device in hand.

NOTE The use of a remote control outside the operator's work station can have significant implications on the operator's safety. Detailed requirements will be specified in the next edition of this part of ISO 4254.

**8.1.2.1.3** The operator's manual shall give instructions on how to safely inspect and service the drums using the remote operating control device provided for that purpose [see 10.1.5 b)].

### 8.2 Basket (cotton stripper and cotton picker)

#### 8.2.1 Lowering basket

It shall be possible to prevent inadvertent lowering of the basket from its raised position. A locking device shall be provided for service and maintenance work under the raised basket. If the locking device is controlled

manually, a safety sign shall be provided on the machine drawing attention to the hazard of working under the raised basket without prior engagement of the locking device [see 10.2.3.2 a)]. Instructions on the use of the locking device shall be provided in the operator's manual [see 10.1.5 c)].

## 8.2.2 Compactor auger

**8.2.2.1** The control system for the compactor auger drives shall be designed such that the augers will not engage unless

- the compactor auger On/Off control is in the “On” position, and
- the conveyor fan On/Off control is in the “On” position, and
- the engine speed control is at “High idle” position.

As an alternative to these three requirements, the design shall be such that the augers will not engage except through activation of a hold-to-run control that requires continuous actuation in order to maintain auger movement.

**8.2.2.2** The operator's manual shall provide information for safe maintenance and servicing [see 10.1.5 d)].

## 8.2.3 Basket safety signs

**8.2.3.1** Safety signs shall be provided for the basket unloading hazards of moving parts during the unloading cycle [see 10.2.3.2 h)].

**8.2.3.2** Safety signs shall be provided for machine stability hazards when turning with the basket raised [see 10.2.3.2 i)].

**8.2.3.3** If provided with a device for manual operation for lowering the basket, this device shall be located outside the hazard zone. A safety sign shall be provided near this device warning of the need to stay clear of the basket when lowering [see 10.2.3.2 j)].

## 8.2.4 Basket handrail

A handrail complying with 5.3.7.2 (see Figure 5) shall be provided on top of the basket for service and maintenance work.

## 8.3 Operating fluids

With reference to 5.9.3, filler necks on cotton harvesters that require high ground clearance for water tanks, fuel tank and engine shall be located in a height of not more than 2 000 mm from the ground surface or not more than 1 500 mm from a platform or step.

## 9 Verification of the safety requirements or protective measures

See Table 2.

**Table 2 — List of safety requirements and/or protective measurements and their verification**

Subclause	Verification			Requirement
	Inspection <sup>a</sup>	Measurement <sup>b</sup>	Test	
5.2.1	X	X	—	Shall be verified in accordance with ISO 15077 and ISO 3767-1 and ISO 3767-2.
5.2.2	—	X	—	Shall be verified by measuring the actuating force and the clearance of the controls.
5.3.1.6	X	—	X	Shall be verified in accordance with ISO 3776-1 and ISO 3776-2.
5.3.2.1.5	X	—	X	Shall be verified in accordance with ISO 3776-1 and ISO 3776-2.
5.3.3	—	X	—	Shall be verified by measuring the position and clearance.
5.3.4	X	X	—	Shall be verified by measuring the clearance, hand reach and foot reach.
5.3.6	X	X	X	Shall be verified by using the boarding means and measurement of dimensions
5.3.9.1	X	X	X	Shall be verified by operating the header disengagement system.
5.3.11.5	X	—	X	Shall be verified in accordance with ISO 9533.
5.3.12.2	X	X	X	Shall be verified by operating the door and measuring the opening dimensions.
5.3.12.3	—	X	—	Shall be verified by measuring the interior dimensions.
5.3.12.5	—	X	—	Shall be verified by measuring the overpressure with all openings of the cabin closed.
5.4	X	X	—	Shall be verified by measuring the dimensions of the boarding means to other than operator's work station.
5.5.3	—	X	—	Shall be verified by measuring the force for folding the elements while using the handles or integral parts identified for that purpose.
5.7	X	—	X	Shall be verified by operating the automatic guidance system.
5.9.3.1	—	X	—	Shall be verified by measuring the height for carrying out the filling operation.
5.9.4.1	X	—	X	Shall be verified by carrying out maintenance or service operations.
5.9.7.1	X	—	X	Shall be verified by carrying out greasing or lubrication operations.
5.12	X	—	X	Shall be verified by operating the header drive.
5.14.2	—	X	X	Shall be verified in accordance with Annex B of ISO 4254-1 and Annex B of this part of ISO 4254.
6.3.1	—	X	—	Shall be verified by measuring the clearance between the outer components of the reel and adjacent fixtures.
6.4.1.1	X	X	X	Shall be verified in accordance with ISO 5687.

Table 2 (continued)

Subclause	Verification			Requirement
	Inspection <sup>a</sup>	Measurement <sup>b</sup>	Test	
6.4.1.3	—	X	—	Shall be verified by measuring the operating force of the parts or components.
6.4.3	X	X	—	Shall be verified by measuring the position and dimensions of the cover.
6.4.4	—	X	—	Shall be verified by measuring distances between the auger circumference and the outer edge of the grain tank.
6.4.5.2.1	X	X	X	Shall be verified by operating the discharge auger disengagement system.
6.5.1.1	X	—	X	Shall be verified by swivelling the covers.
6.5.2.1	X	X	—	Shall be verified by measuring the distances between the working tools and the outer edge of picking device or guard and between the cover and the tip path of the working tools.
6.5.2.2	X	X	—	Shall be verified by measuring the safety distances between the working tools and the rear barrier and between the guard and the tool path
6.6.1	X	—	X	Shall be verified by operating the disengagement control for the threshing mechanism.
6.6.2	X	X	X	Shall be verified by operating the straw chopper and by measuring the safety distances.
6.6.3	X	X	—	Shall be verified by measuring the safety distances in the different positions.
6.6.4	X	X	—	Shall be verified by measuring the safety distances in the different positions.
6.7	X	—	X	Shall be verified by carrying out the emptying the stone trap.
7.2.3	X	X	—	Shall be verified by measuring the safety distances.
7.2.5	X	X	X	Shall be verified by operating the additional control for the reverser and measuring the distance between the control and outer edge of feed roller housing.
7.3	X	—	X	Shall be verified by operating the cutterhead drive.
7.4	X	X	X	Shall be verified by disengaging the cutterhead drive and measuring the run down time.
8.1.2.1.2	X	—	X	Shall be verified by carrying out inspection and lubrication operations.
8.2.1	X	—	X	Shall be verified by carrying out maintenance or service operations.
8.2.2.1	X	—	X	Shall be verified by operating the compactor augers.
8.3	—	X	—	Shall be verified by measuring the height for carrying out the filling operation.

<sup>a</sup> Inspection: visual check of the machine to see that everything is in place.

<sup>b</sup> Measurement: determination of a value by using some form of device or instrument

## 10 Information for use

### 10.1 Operator's manual

#### 10.1.1 General

10.1.1.1 Content and presentation shall be in accordance with ISO 3600.

10.1.1.2 Comprehensive instructions and information on all aspects of the safe use of the machine, including suitable clothing and personal protective equipment requirements and the need for training, if necessary, shall be provided by the manufacturer in the operator's manual. The following useful items to be included in the operator's manual are general:

- a) information relating to transport, handling and storage of the machine;
- b) information relating to installation and commissioning of the machine;
- c) information relating to the machine itself;
- d) information relating to the use of the machine;
- e) information for maintenance;
- f) information relating to de-commissioning, dismantling and disposal;
- g) information for emergency situations;
- h) maintenance instructions provided for skilled persons and those provided for unskilled persons, which should be kept clearly separated from each other.

10.1.1.3 The information and items given in ISO 4254-1:2008, 8.1.3, apply.

#### 10.1.2 All machines

In particular, the following information and points shall be provided:

- a) description and function of all controls, including an explanation of the identities and symbols used;
- b) how to adjust the operator's seat;
- c) intended use of the instructional seat (if provided);
- d) explanation of warnings used;
- e) how to clean the windscreen;
- f) how to adjust the rear-view mirrors;
- g) information about selection, cleaning and replacement intervals of the air filter, if the machine is equipped with a cabin;
- h) explanation of the automatic guidance system (if provided);
- i) warnings regarding hot surfaces of the engine and associated parts;
- j) manual operation of individual assemblies and, if required, use of special tools;
- k) instructions on how to change operating fluids, including safety aspects;

- l) location and use of devices for maintaining machine parts in a raised position during service and maintenance;
- m) location and method for use of tie-down and jacking points;
- n) instructions about greasing and lubrication;
- o) recommendations about number, type and location of fire extinguishers;
- p) residual risks associated with overhead power lines, when the machine exceeds 4 m in height during any mode of operation;
- q) recommendation to operate machines equipped with a cabin with all doors and windows closed.

### 10.1.3 Combine harvesters

In particular, the following information and points shall be provided:

- a) residual risks associated with the gathering and cutting mechanism;
- b) residual risks associated with, and instructions for, safe access into the grain tank;
- c) residual risks associated with, and instructions about, the cleaning of the clean grain and returns handling system;
- d) residual risks associated with the maize picker head;
- e) residual risks associated with running on working parts of the rear straw chopper, straw spreader and chaff spreader;
- f) residual risks associated with thrown objects ejected by the rear straw chopper, straw spreader and chaff spreader.

### 10.1.4 Forage harvesters

**10.1.4.1** In particular, the following information and points shall be provided:

- a) residual risks associated with the infeed mechanisms;
- b) residual risks associated with the use of the knife sharpening device.

**10.1.4.2** In addition, the following information can be useful and is recommended for inclusion:

- a) use of personal protection equipment when handling with silage additives and blade sharpening;
- b) residual risks associated with the replacement of knives.

### 10.1.5 Cotton harvesters

In particular, the following information and points shall be provided:

- a) residual risks associated with the gathering mechanisms;
- b) residual risks associated with, and instructions on how to, safely inspect and service the drums;
- c) instructions on the use of the locking device for the basket;
- d) instructions for safe maintenance and servicing of the compactor auger.

## 10.2 Marking

### 10.2.1 General

All machines shall be marked legibly and indelibly with at least the following minimum information:

- name and address of the manufacturer;
- designation of series or type;
- serial number, if any.

### 10.2.2 Instructional signs

The following instructions shall be provided on the machine:

- a) identification of controls;
- b) identification of integral parts of the machine for use as handles;
- c) indications about the operating conditions of the automatic guidance system, if present;
- d) identification of supports for service and maintenance of raised parts of the machine;
- e) identification of tie-down and jacking points.

### 10.2.3 Safety signs

**10.2.3.1** Safety signs shall conform to the requirements of ISO 11684 and shall be appropriately affixed to the machine as necessary to alert the operator and others of the potential hazard(s) that can cause personal injury during normal operations and servicing.

**10.2.3.2** In particular, safety signs shall be provided on the machine in all appropriate places, drawing attention to the following:

- a) residual risks due to servicing and maintenance under raised parts without prior engagement of the locking device;
- b) possible contact with overhead power lines, clearly visible from the operator's position;
- c) residual risks of shearing and pinching of the gathering and/or cutting mechanisms;
- d) shearing and pinching points outside the cutting table side panels caused by the cutter bar or its drive mechanism;
- e) residual risks of shearing and pinching on the feeding mechanism of maize picker head;
- f) residual risks due to running on working parts of rear straw chopper, straw spreader and chaff spreader;
- g) residual risks of thrown objects ejected by rear straw chopper, straw spreader and chaff spreader;
- h) residual risks of moving parts during basket unloading;
- i) residual risks of machine stability when turning with the basket raised;
- j) stay clear of the basket when operating the manual lowering valve of the basket.



## Annex A (normative)

### Identification of hand controls by colour coding

#### A.1 Purpose

The purpose of this annex is to define a system of colour coding hand controls which will aid in identification by operators. Controls are described in ISO 15077.

#### A.2 General

**A.2.1** For the purposes of this annex, hand controls include, but are not limited to, levers, switches, knobs, handles, and buttons, which the operator manipulates to activate or control machine functions.

**A.2.2** When new types of hand control are adopted or combination controls are used, the colour shall be selected in accordance with the primary function.

**A.2.3** If it is not practical to colour code the control, it is sufficient to colour code either the area surrounding the control or the identification of that control rather than the control.

**A.2.4** Colour coding does not replace the need for symbolic identification. Controls for functions that are not obvious shall be identified in accordance with ISO 3767-1 and ISO 3767-2.

#### A.3 Colour coding

**A.3.1** Red shall be used for single-function engine stop controls. Where key switches, ignition switches or hand throttles are used to stop the engines, the "Off" or "Stop" positions shall be indicated with red lettering and/or symbols.

**A.3.2** Orange shall be used only for machine ground motion controls, such as engine speed controls, transmission controls, parking brakes or park-locks, and independent emergency brakes.

**A.3.2.1** Where the engine speed and engine stop controls are combined, the controls may be red.

**A.3.2.2** Steering wheels or steering controls may be black or any colour other than red or yellow.

**A.3.3** Yellow shall be used only for function controls which involve the engagement of mechanisms such as power take-offs, separators, cutterheads, feed rolls, picking units, elevators and unloading augers.

**A.3.4** Black or some other dark colour harmonized with the decor chosen by the manufacturer shall be used for all controls not covered by A.3.1, A.3.2 or A.3.3, such as the following positioning and adjusting functions.

**A.3.4.1** Component lift or position, such as implement hitch, header height, blade shift and reel lift.

**A.3.4.2** Control of unloading components, such as, spout cap, unloading auger swing and bin dump.

**A.3.4.3** Mechanism setting and adjustment, such as chokes, cylinder speed, concave space, seat adjustment, steering column, transmission disconnect, concave lock, lift stops, rockshaft stops, reel speed and flow dividers.

**A.3.4.4** Machine lights, such as headlights, work or flood lights, taillights, flashers and turn signals.

**A.3.4.5** Cabin comfort, such as pressurizer, cooling, heating and windshield wipers.

## Annex B (normative)

### Noise measurement

#### B.1 General

Unless otherwise specified in this annex, the information necessary to carry out efficiently and under standardized conditions for determination of noise emission values given in ISO 4254-1:2008, Annex B, apply.

#### B.2 Machine configuration and operating conditions

Noise measurements shall be made with the machine stationary on a short-grassed or soil surface complying with the acoustical environment, weather conditions and background noise specified in ISO 5131:1996, Clause 5. The configuration of the machine shall reflect in as far as possible the harvesting configuration, requiring the following.

- The front attachment shall be installed and adjusted to a height as low as possible but without touching the ground during the test runs; when different front attachments are offered, the test shall be repeated for each attachment. The noise declaration shall give at least the highest value measured and indicate the attachment for which it has been obtained.
- The front attachment and all harvesting elements shall be run during the test runs.
- Harvesting elements with variable speed shall be run at 75 % of their maximum speed.
- Harvesting elements with a high–low speed setting shall be run at high speed.
- Harvesting elements with more than two speed settings shall be run at a medium speed.
- The engine shall be run at the high idle speed.
- Any residue management system (straw chopper, chaff spreader, etc.), when installed, shall be run during the test runs.
- The fuel tank shall be filled to between 75 % and 100 % of its capacity during the test runs.
- Grain tanks/hoppers shall be empty and extensions, when installed, shall be in the raised position.
- The unloading tube on combine harvesters shall be in the closed position and the unloading system shall not be engaged.
- The unloading spout on a forage harvester shall point to the rear and be adjusted midway in height.

### B.3 Cabins and auxiliaries

If a cabin is fitted, the provisions of B.2 and the following apply.

- The emission sound pressure level shall be measured with all openings (i.e. doors, windows, hatches and windscreen) closed and with all auxiliaries (i.e. air-conditioning fans and other possible electrical auxiliaries such as defrosters) running at the maximum setting. The value obtained shall be stated in the noise declaration.
- If the machine is designed to operate with all openings open, an additional set of measurements may be taken with the machine in this condition. The exception is that the windscreen shall remain closed. If such measurements are carried out, the value obtained shall be either given in the noise declaration or made available to a user on request.
- Additional noise measurements may optionally be carried out with the engine running at maximum speed and air-conditioning and all possible auxiliaries in operation at their maximum settings. If such measurements are carried out, the value obtained shall be either given in the noise declaration or made available to users on request.
- Additional noise measurements may optionally be carried out with the engine stopped and auxiliaries such as ventilating fans and other possible electrical auxiliaries working at their maximum settings. It shall be confirmed that at least the nominal energy input of the auxiliary equipment is applied to the equipment terminals. If such measurements are carried out, values obtained shall be made available to users on request.

## Bibliography

- [1] ISO 8909-1:1994, *Forage harvesters — Part 1: Vocabulary*
- [2] ISO 13849-1:1999, *Safety of machinery — Safety-related parts of control systems — Part 1: General principles for design*



---

---

**ICS 65.060.50**

Price based on 46 pages