

INTERNATIONAL STANDARD

ISO 4254-1

Fifth edition
2013-05-01

Agricultural machinery — Safety — Part 1: General requirements

*Matériel agricole — Sécurité —
Partie 1: Exigences générales*



Reference number
ISO 4254-1:2013(E)

© ISO 2013



COPYRIGHT PROTECTED DOCUMENT

© ISO 2013

All rights reserved. Unless otherwise specified, no part of this publication may be reproduced or utilized otherwise in any form or by any means, electronic or mechanical, including photocopying, or posting on the internet or an intranet, without prior written permission. Permission can be requested from either ISO at the address below or ISO's member body in the country of the requester.

ISO copyright office
Case postale 56 • CH-1211 Geneva 20
Tel. + 41 22 749 01 11
Fax + 41 22 749 09 47
E-mail copyright@iso.org
Web www.iso.org

Published in Switzerland

Contents

	Page
Foreword	v
Introduction	vii
1 Scope	1
2 Normative references	1
3 Terms and definitions	3
4 Safety requirements and/or measures applicable to all machines	5
4.1 Fundamental principles, design guidance.....	5
4.2 Protection from moving parts involved in the work.....	5
4.3 Noise.....	5
4.4 Vibration.....	6
4.5 Controls.....	6
4.6 Automatic mode of operation.....	7
4.7 Operator stations.....	7
4.8 Other than operator stations.....	10
4.9 Folding elements.....	12
4.10 Strength requirements for guards and barriers.....	12
4.11 Supports for service and maintenance.....	12
4.12 Electric equipment.....	13
4.13 Hydraulic components and fittings.....	13
4.14 Pneumatic systems.....	13
4.15 Operating fluids.....	13
4.16 Manual operation of individual assemblies.....	14
4.17 Service and handling of machine parts.....	14
4.18 Electromagnetic compatibility.....	14
4.19 Emergency stop.....	14
4.20 Safety-related parts of control systems.....	15
5 Safety requirements and/or measures — Self-propelled ride-on machines	15
5.1 Operator station.....	15
5.2 Moving the machine.....	18
5.3 Electric.....	19
5.4 Fuel tank.....	19
5.5 Hot surfaces.....	19
5.6 Exhaust gases.....	19
5.7 Roll- and tip-over.....	19
6 Safety requirements and/or measures — Mounted, semi-mounted and trailed machines	20
6.1 Controls.....	20
6.2 Stability.....	20
6.3 Hitches for towing.....	21
6.4 Transmission of mechanical power between self-propelled machines/tractors and recipient machinery.....	21
6.5 Hydraulic, pneumatic and electrical connections with a self-propelled machine or towing vehicle.....	22
7 Verification of safety requirements or protective measures	22
8 Information for use	23
8.1 General.....	23
8.2 Operator's manual.....	23
8.3 Safety and instructional signs.....	24
8.4 Marking.....	25
Annex A (informative) List of significant hazards	26
Annex B (normative) Noise test code (engineering method grade 2)	30

Annex C (normative) Strength tests	34
Annex D (informative) Stability of tractor machine combinations	36
Bibliography	38

.....

Foreword

ISO (the International Organization for Standardization) is a worldwide federation of national standards bodies (ISO member bodies). The work of preparing International Standards is normally carried out through ISO technical committees. Each member body interested in a subject for which a technical committee has been established has the right to be represented on that committee. International organizations, governmental and non-governmental, in liaison with ISO, also take part in the work. ISO collaborates closely with the International Electrotechnical Commission (IEC) on all matters of electrotechnical standardization.

The procedures used to develop this document and those intended for its further maintenance are described in the ISO/IEC Directives, Part 1. In particular the different approval criteria needed for the different types of ISO documents should be noted. This document was drafted in accordance with the editorial rules of the ISO/IEC Directives, Part 2. www.iso.org/directives

Attention is drawn to the possibility that some of the elements of this document may be the subject of patent rights. ISO shall not be held responsible for identifying any or all such patent rights. Details of any patent rights identified during the development of the document will be in the Introduction and/or on the ISO list of patent declarations received. www.iso.org/patents

Any trade name used in this document is information given for the convenience of users and does not constitute an endorsement.

The committee responsible for this document is ISO/TC 23, *Tractors and machinery for agriculture and forestry*, Subcommittee SC 3, *Safety and comfort*.

This fifth edition of ISO 4254-1 cancels and replaces the fourth edition (ISO 4254-1:2008), which has been technically revised. In particular, requirements relating to the following have been introduced:

- vibrations;
- protection of moving parts;
- operation of machine parts;
- operating fluids;
- foldable barriers;
- PTO drive shaft guard clearance;
- emergency stop controls;
- safety related parts of control systems;
- roll-over and tip-over hazards.

ISO 4254 consists of the following parts, under the general title *Agricultural machinery — Safety*:

- *Part 1: General requirements*
- *Part 5: Power-driven soil-working machines*
- *Part 6: Sprayers and liquid fertilizer distributors*
- *Part 7: Combine harvesters, forage harvesters and cotton harvesters*
- *Part 8: Solid fertilizer distributors*
- *Part 9: Seed drills*
- *Part 10: Rotary tedders and rakes*

ISO 4254-1:2013(E)

- *Part 11: Pick-up balers*
- *Part 12: Rotary disc and drum mowers and flail mowers*
- *Part 13: Large rotary mowers*

ISO 4254-2, *Anhydrous ammonia applicators*, has been withdrawn.

ISO 4254-3, *Tractors*, has been cancelled and replaced by ISO 26322 (all parts), *Tractors for agriculture and forestry — Safety*.

ISO 4254-4, *Tractors and machinery for agriculture and forestry — Technical means for providing safety — Part 4: Forestry winches*, has been cancelled and replaced by ISO 19472, *Machinery for forestry — Winches — Dimensions, performance and safety*.

www.iso.org

Introduction

This document is a type-C standard as stated in ISO 12100.

The machinery concerned and the extent to which hazards, hazardous situations and events are covered are indicated in the scope of this document.

When requirements of this type-C standard are different from those which are stated in type-A or type-B standards, the requirements of this type-C standard take precedence over the requirements of the other standards for machines that have been designed and built according to the requirements of this type-C standard.

Agricultural machinery — Safety —

Part 1: General requirements

1 Scope

This part of ISO 4254 specifies the safety requirements and the means of their verification for the design and construction of self-propelled ride-on machines, mounted, semi-mounted and trailed machines used in agriculture in order to deal with the hazards which are typical for most of the machines. In addition, it specifies the type of information on safe working practices including information about residual risks to be provided by the manufacturer.

This document deals with significant hazards, hazardous situations and events, as listed in [Annex A](#), relevant to this agricultural machinery when used as intended and under the conditions of misuse foreseeable by the manufacturer during normal operation and service.

This part of ISO 4254 is not applicable to

- agricultural or forestry tractors,
- aircraft and air-cushion vehicles used in agriculture,
- lawn and garden equipment,
- machine-specific components or functions (e.g. working tools and/or processes).

This part of ISO 4254 is not applicable to hazards related to periodic service, machine conversion and repairs intended to be carried out by professional service personnel, environmental hazards, road safety (e.g. steering, braking), or to the power take-off (PTO) drive shaft; neither is it applicable to guards of moving parts for power transmission except for strength requirements for guards and barriers.

This part of ISO 4254 is not applicable to machines which are manufactured before the date of its publication.

Not all of the hazards dealt with by this part of ISO 4254 are necessarily present on a particular machine. A risk assessment should be carried out by the manufacturer to determine the hazards that are applicable and any hazards in addition to those dealt with by this part or a relevant machine-specific part. The requirements of a machine-specific part of ISO 4254 take precedence over the requirements of this part.

2 Normative references

The following referenced documents, in whole or in part, are normatively referenced in this document and are indispensable for its application. For dated references, only the edition cited applies. For undated references, the latest edition of the referenced document (including any amendments) applies.

ISO 3600:1996, *Tractors, machinery for agriculture and forestry, powered lawn and garden equipment — Operator's manuals — Content and presentation*

ISO 3744:2010, *Acoustics — Determination of sound power levels and sound energy levels of noise sources using sound pressure — Engineering methods for an essentially free field over a reflecting plane*

ISO 3767-1:1998, *Tractors, machinery for agriculture and forestry, powered lawn and garden equipment — Symbols for operator controls and other displays — Part 1: Common symbols*

ISO 4254-1:2013(E)

- ISO 3767-2:2008, *Tractors, machinery for agriculture and forestry, powered lawn and garden equipment — Symbols for operator controls and other displays — Part 2: Symbols for agricultural tractors and machinery*
- ISO 3776-1:2006, *Tractors and machinery for agriculture — Seat belts — Part 1: Anchorage location requirements*
- ISO 3776-2:2013, *Tractors and machinery for agriculture — Seat belts — Part 2: Anchorage strength requirements*
- ISO 3776-3:2009, *Tractors and machinery for agriculture — Seat belts — Part 3: Requirements for assemblies*
- ISO 3795:1989, *Road vehicles, and tractors and machinery for agriculture and forestry — Determination of burning behaviour of interior materials*
- ISO 4253:1993, *Agricultural tractors — Operator's seating accommodation — Dimensions*
- ISO 4413:2010, *Hydraulic fluid power — General rules and safety requirements for systems and their components*
- ISO 4414:2010, *Pneumatic fluid power — General rules and safety requirements for systems and their components*
- ISO 5008:2002, *Agricultural wheeled tractors and field machinery — Measurement of whole-body vibration of the operator*
- ISO 5353:1995, *Earth-moving machinery, and tractors and machinery for agriculture and forestry — Seat index point*
- ISO 10975:2009, *Tractors and machinery for agriculture — Auto-guidance systems for operator-controlled tractors and self-propelled machines — Safety requirements*
- ISO 11201:2010, *Acoustics — Noise emitted by machinery and equipment — Determination of emission sound pressure levels at a work station and at other specified positions in an essentially free field over a reflecting plane with negligible environmental corrections*
- ISO 11204:2010, *Acoustics — Noise emitted by machinery and equipment — Determination of emission sound pressure levels at a work station and at other specified positions applying accurate environmental corrections*
- ISO 11684:1995, *Tractors, machinery for agriculture and forestry, powered lawn and garden equipment — Safety signs and hazard pictorials — General principles*
- ISO/TR 11688-1:1995, *Acoustics — Recommended practice for the design of low-noise machinery and equipment — Part 1: Planning*
- ISO 12100:2010, *Safety of machinery — General principles for design — Risk assessment and risk reduction*
- ISO 13849-1:2006, *Safety of machinery — Safety-related parts of control systems — Part 1: General principles for design*
- ISO 13849-2:2012, *Safety of machinery — Safety-related parts of control systems — Part 2: Validation*
- ISO 13850:2006, *Safety of machinery — Emergency stop — Principles for design*
- ISO 13857:2008, *Safety of machinery — Safety distances to prevent hazard zones being reached by upper and lower limbs*
- ISO 14982:1998, *Agricultural and forestry machinery — Electromagnetic compatibility — Test methods and acceptance criteria*
- ISO 15077:2008, *Tractors and self-propelled machinery for agriculture — Operator controls — Actuating forces, displacement, location and method of operation*
- ISO 16231-1:2013, *Self-propelled agricultural machinery — Assessment of stability — Part 1: Principles*
- ISO 25119-1:2010, *Tractors and machinery for agriculture and forestry — Safety-related parts of control systems — Part 1: General principles for design and development*

ISO 25119-2:2010, *Tractors and machinery for agriculture and forestry — Safety-related parts of control systems — Part 2: Concept phase*

ISO 25119-3:2010, *Tractors and machinery for agriculture and forestry — Safety-related parts of control systems — Part 3: Series development, hardware and software*

ISO 25119-4:2010, *Tractors and machinery for agriculture and forestry — Safety-related parts of control systems — Part 4: Production, operation, modification and supporting processes*

3 Terms and definitions

For the purposes of this document, the terms and definitions given in ISO 12100 and the following apply.

3.1

normal operation

use of the machine for the purpose intended by the manufacturer by an operator familiar with the machine characteristics and complying with the information for operation, and safe practices, as specified by the manufacturer in the operator's manual and by signs on the machine

Note 1 to entry: Normal operation includes the preparation and storage of the machine, such as

- mounting and dismounting,
- swinging components into work position and vice versa,
- adding or removing ballast and picking up and setting down attachments,
- filling substances and materials that are needed and consumed during the use of the machine (such as twine spools, seed, fertilizers, water and plant protection products),
- the adjustment and setting of the machine, or the combination tractor-machine for the specific condition of the field and/or the crop, and
- clearing of blockages in the crop flow or clearing accumulation of debris.

3.2

service

activities to be done as required and/or at regular intervals by an operator familiar with the machine characteristics and complying with the information for service and safe practices, as specified by the manufacturer in the operator's manual and by signs on the machine, in order to maintain the proper function of the machine

Note 1 to entry: Service includes activities such as fuelling, cleaning, washing, topping up fluid levels, greasing, adjusting (e.g. belts and chains) and the replacement of consumable articles such as light bulbs and fast-wearing parts (e.g. cutting elements).

3.3

three-point contact support

system which permits a person to simultaneously use two hands and a foot or two feet and one hand when boarding, or dismounting from, a machine

3.4

inadvertent contact

unplanned exposure of a person to a hazard resulting from the person's action during normal operation and service of the machine

**3.5
hand and foot reach**

**3.5.1
hand and foot reach**

<machine without cab> reach defined for hands by a sphere of 1 000 mm radius, centred on the seat centreline, 60 mm in front of and 580 mm above the seat index point (SIP) as defined in ISO 5353 and for feet by a hemisphere of 800 mm radius, centred on the seat centreline at the front edge of the cushion and extending downwards, with the seat in its central position See [Figure 1](#).

Dimensions in millimetres

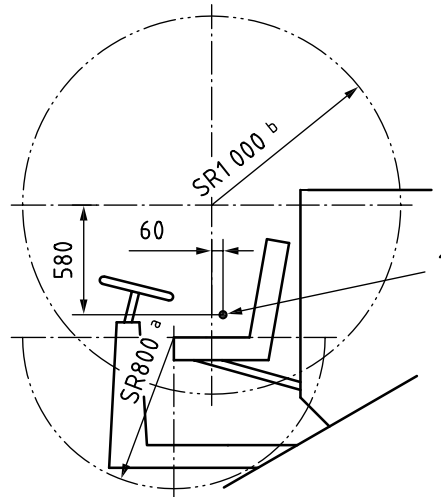

Key

- 1 SIP (seat index point)
- a Hemisphere radius (feet).
- b Sphere radius (hands).

Figure 1 — Hand and foot reach

**3.5.2
hand and foot reach**

<machine with cab> reach defined for hands by those portions, lying within the cab, of a sphere of 1 000 mm radius, centred on the seat centreline, 60 mm in front of and 580 mm above the seat index point (SIP) as defined in ISO 5353, and for feet by those portions, lying within the cab, of a hemisphere of 800 mm radius centred on the seat centreline at the front edge of the cushion and extending downwards, with the seat in its central position

**3.6
normal access**

access for operators for process control and adjusting, during normal operation or service, according to the intended use of the machine

**3.7
automatic mode**

machine function that consists of either repetitive work cycles or a single work cycle that, once initiated by the intentional actuation of a control by the operator or by the machine itself, either repeats a cycle or comes to stop at the completion of a cycle without operator intervention as a part of normal machine operation

3.8 work cycle

series of machine-functional events that recur in succession and that either lead back to the starting point (e.g. a bale knotter system) or come to a predetermined stopping point (e.g. folding or unfolding of an implement wing)

3.9 stationary operation

application of the machine while the machine is not travelling in any direction as the equipment performs its function

4 Safety requirements and/or measures applicable to all machines

4.1 Fundamental principles, design guidance

4.1.1 The machinery shall comply with the safety requirements and/or protective measures of [Clauses 4 and 5](#) or [6](#). In addition, the machinery shall be designed according to the principles of ISO 12100:2010 for relevant but not significant hazards, which are not dealt with by this document.

Not all of the hazards dealt with by this part of ISO 4254 are necessarily present on a particular machine. A risk assessment should be carried out by the manufacturer to determine the hazards that are applicable and any hazards in addition to those dealt with by this part or a relevant machine-specific part. The manufacturer is responsible for the specification and provision of safety measures to deal with additional hazards. The requirements of a machine-specific part of ISO 4254 take precedence over the requirements of this part.

4.1.2 Unless otherwise specified in this part of ISO 4254, safety distances shall comply with the requirements given in ISO 13857:2008, Table 1, 3, 4 or 6, as appropriate.

4.1.3 Functional components which need to be exposed for proper function, drainage or cleaning shall be guarded without causing other hazards, for example risk of fire due to the accumulation of organic material during the intended use, and without interfering with the proper function, drainage or cleaning.

4.2 Protection from moving parts involved in the work

Within the intended use and reasonably foreseeable misuse of the machine, if guards cannot be used to prevent inadvertent contact with moving parts involved in the machine's work process, then other appropriate measures to prevent inadvertent contact shall be provided.

During the risk assessment process selection of such appropriate measures shall take into consideration the strategies for risk reduction specified in ISO 12100:2010, and shall consider both normal operation and service operations as specified in the operator's manual.

An example of an appropriate measure is safety distance guarding through the use of a barrier.

4.3 Noise

4.3.1 The technical information given in ISO/TR 11688-1 shall be used as means to design low-noise machinery.

NOTE 1 ISO/TR 11688-2 (see [Reference 3](#)) also gives useful information on noise-generation mechanisms in machinery.

NOTE 2 Noise generation can vary considerably between machinery types. Noise reduction measures are therefore dealt with in product-specific standards.

4.3.2 Noise emission values, if required to be declared, shall be determined in accordance with [Annex B](#).

4.4 Vibration

4.4.1 If vibration emission values are required to be declared, then the weighted root-mean-square acceleration value and the measuring method shall be determined according to

- ISO 5008:2002,
- a relevant machine-specific part to this standard, or
- a measuring method that shall be described in the operator's manual.

Vibration measurements are unnecessary for machines that do not require a ride-on operator.

4.4.2 Mechanical vibrations are caused by the unevenness of the travelling surface and the unbalanced movement of machine-related components such as engine, gearbox, drives and working tools. Technical measures for the reduction of vibrations are, for example, isolators, dampening or suspension systems.

As the origin of vibrations depends on the machine type and the individual design, detailed specifications for vibration reduction measures are specified by the machine-specific parts of ISO 4254.

4.5 Controls

4.5.1 The function of control devices and their different positions shall be identified at the operating position and explained in the operator's manual [see [8.2.3 d](#)]. Symbols shall be in accordance with ISO 3767-1:1998 and ISO 3767-2:2008.

4.5.2 Pedals shall have a slip-resistant surface and be easy to clean.

4.5.3 Hand-operated controls requiring an actuating force ≥ 100 N shall have a minimum clearance, a , of 50 mm between the outer contours or from adjacent parts of the machine (see [Figure 2](#)). Controls requiring an actuating force < 100 N shall have a minimum clearance of 25 mm. This requirement does not apply to fingertip operation controls (e.g. push-buttons, electric switches).

4.5.4 For requirements pertaining to machine-specific controls, see the relevant part(s) of ISO 4254.

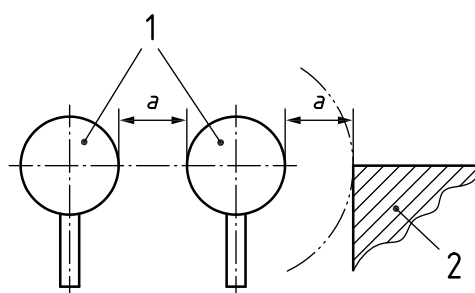

Key

- 1 hand-operated control
- 2 adjacent part
- a minimum clearance

Figure 2 — Clearance around hand-operated controls

4.5.5 Unless specified otherwise in [4.5.3](#) and [4.9.1](#), actuating forces, displacement, location and the method of operation shall be in accordance with ISO 15077:2008.

4.5.6 Controls shall be located outside the hazard zones. This requirement is also applicable to machine components (e.g. hydraulic valves) which need to be manually operated or controlled in case of malfunction of the primary control system.

4.6 Automatic mode of operation

Machinery functioning in automatic mode shall bring itself automatically to a safe state when the work cycle is involuntarily stopped or interrupted (e.g. blockage, overload, malfunction). Following an involuntary stop or interruption, a re-start of the work cycle shall be possible only after an intentional actuation of a control located outside the hazard zone.

4.7 Operator stations

4.7.1 Boarding means

4.7.1.1 General

4.7.1.1.1 If the vertical height of the operator station floor above ground level exceeds 550 mm, measured on level ground and with the specified tyres with the maximum diameter at specified inflation pressure [see 8.2.3 w)], or specified tracks, a boarding means shall be provided. The dimensions shall be as shown in [Figure 3](#).

4.7.1.1.2 Whenever the boarding means is located directly in line and forward of a wheel or track (i.e. within the track of the machine), provision shall be made for a guardrail to be located on the wheel or track side. This does not apply when the machine is in the transport configuration.

Shielding shall be provided on the back of steps or ladders whenever a protruding hand or foot can contact a hazardous part of the machine, e.g. wheel.

4.7.1.2 Steps and ladders

4.7.1.2.1 The height of the first step shall be achieved with the specified tyres and with the maximum diameter at specified inflation pressure [see 8.2.3 w)]. The vertical distance between successive steps shall be equal within a tolerance of ± 20 mm. Each step shall have a slip-resistant surface, a lateral stop at each end and be so designed (e.g. mudguards, perforated steps) that an accumulation of mud and/or snow is minimized under normal work conditions.

A flexible connection(s) between the first and second steps is permitted.

4.7.1.2.2 Dimensions for ladders and steps used as boarding means for operator stations shall be in accordance with [Table 1](#) and [Figure 3](#).

Table 1 — Dimensions for boarding means for operator stations

	Ladders	Steps
α	70° to 90°	20° to 70°
$A + D$ min	150	150
B max	300	300
C min	120	120
D min	50	150
$2B + G$ max	-	800
W min	300	300

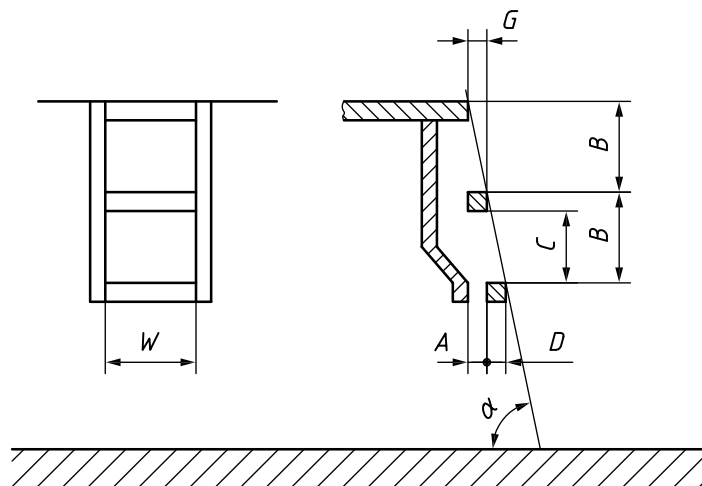
**Key**

- A toe clearance
- B vertical distance between tread surface of successive steps
- C minimum clearance between successive steps
- D tread depth
- G horizontal distance between leading edge of successive steps
- W width of step or rung
- α angle of inclination

Figure 3 — Dimensions of boarding means for operator stations

4.7.1.2.3 If parts of the boarding means are moveable, the operating force shall not exceed 200 N as the average value when moving from the start position to the stop position. The peak(s) shall not exceed 400 N.

4.7.1.2.4 When moving the boarding means, there shall be no shearing, pinching or uncontrollable movement hazards to the operator.

4.7.1.2.5 Where, on tracked machines, the track shoes and track pad surfaces are intended to be used as access steps, three-point contact support shall be provided to ensure safe boarding for the operator.

4.7.1.3 Handrails/handhold

4.7.1.3.1 Handrails or handholds shall be provided on both sides of the boarding means and shall be so designed that the operator can maintain three-point contact support at all times. The width of the handrail/handhold cross section shall be between 25 mm and 38 mm. The lower end of the handrail/handhold shall be located no higher than 1 500 mm from the ground surface. A minimum clearance of 50 mm shall be provided for hand clearance between the handrail/handhold and the adjacent parts except at attaching points.

4.7.1.3.2 A handrail/handhold shall be provided above the uppermost step/rung of the boarding means at a height between 850 mm and 1 100 mm above the uppermost step/rung. The handhold shall be at least 150 mm long.

4.7.2 Platforms

4.7.2.1 Platforms shall be flat and have a slip-resistant surface and, if necessary, provision for drainage.

4.7.2.2 Platforms — except those only used when the machine is stationary and which are less than 1 000 mm above the ground — shall be equipped with a foot guard, hand rail and intermediate rail around the edge of the platform with the dimensions shown in Figure 4. No foot guard shall be provided at the entrance of the platform.

In addition, if static machine components are used as a foot guard, handrail and/or intermediate rail, the requirements given in 4.7.1.3.1 and 4.7.1.3.2 shall be fulfilled.

Dimensions in millimetres

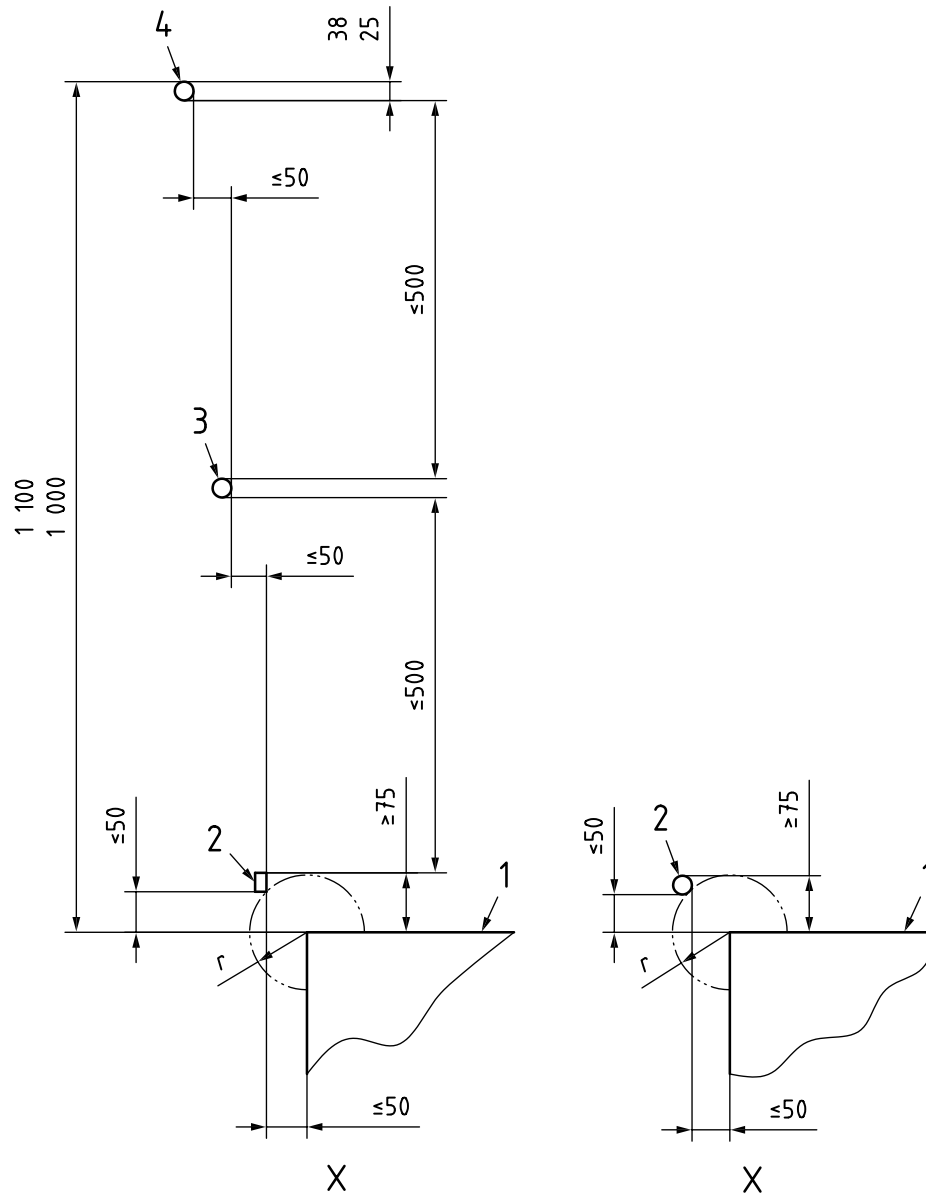

Key

- r radius 50 mm max
- 1 platform
- 2 foot guard
- 3 intermediate rail
- 4 handrail

Figure 4 — Platform foot guard and hand rail

4.7.2.3 If the boarding means of platforms and cabs are made movable for transport purposes, provision shall be made for railing off access to the platform or cab. For cabs equipped with a door, the cab door satisfies this requirement.

4.7.3 Operator seat

Machines shall be provided with a seat for each ride-on driver and operator.

When for technical reasons or due to the function, the driver or operator needs to stand upright on the machine, this exemption and relevant specific hazards may be dealt with in the machine-specific standard of the machine concerned.

4.8 Other than operator stations

4.8.1 General

Service locations that are more than 2 000 mm above the ground, or 1 500 mm for those locations involving filling or topping up of fluids or bulk materials, shall be provided with a suitable place for the operator to stand and, if the place to stand is more than 550 mm above the ground, with a boarding means.

4.8.2 Place to stand

4.8.2.1 A place provided for standing shall have sufficient space for both of the operator's feet, be flat and have a slip-resistant surface. Depending on the machine configuration, it may consist of two separate surfaces and may use machine components. It shall be positioned so the operator can maintain stability while carrying out the service required and be on the same height level with a tolerance of ± 50 mm.

4.8.2.2 Handhold(s) and/or railings shall be provided in order to allow three-point contact. Parts of the machine can be considered to fulfil this requirement.

4.8.2.3 When access is needed above or next to the PTO (power take-off) drive shaft, an adequate place to stand and boarding means shall be provided in order to eliminate the need to use the PTO drive shaft or its guard as a step or a place to stand.

4.8.3 Boarding means

4.8.3.1 If the place to stand for service is more than 550 mm above the ground (or the operator platform), a boarding means shall be provided.

4.8.3.2 Boarding means shall be provided with foot supports (e.g. rungs or steps) and handholds.

If static machine components are used as foot supports and/or handholds, the requirements given in [4.7.1.2.1](#) and [4.7.1.3.1](#) and [4.7.1.3.2](#) shall be fulfilled.

4.8.3.3 Boarding means shall comprise a series of steps as shown in [Figure 5](#) and shall be in accordance with a) or b) or c) as follows.

- a) The inclination α shall be between 70° and 90° from the horizontal (see [Figure 5](#)). Each step shall have a slip-resistant surface, a lateral stop at each end and be so designed that any accumulation of mud and/or snow is minimized in the normal conditions of work. The vertical and horizontal distance between successive steps shall be within a tolerance of ± 20 mm.
- b) The boarding means shall be a ladder. The top side of each rung shall have a horizontal slip-resistant surface at least 30 mm from front to back. If rungs can be used as handholds, then rectangular section rungs shall have corner radii ≥ 5 mm.

c) The boarding means shall be in accordance with 4.7.1.2.

4.8.3.4 If boarding means are located such that there is the hazard of inadvertent contact with the PTO drive shaft guard or PIC guard by reaching through the boarding means with foot or hand, shielding shall be provided on the rear of the boarding means.

4.8.3.5 By design, PTO drive shafts and their guards shall not be considered as steps.

Dimensions in millimetres

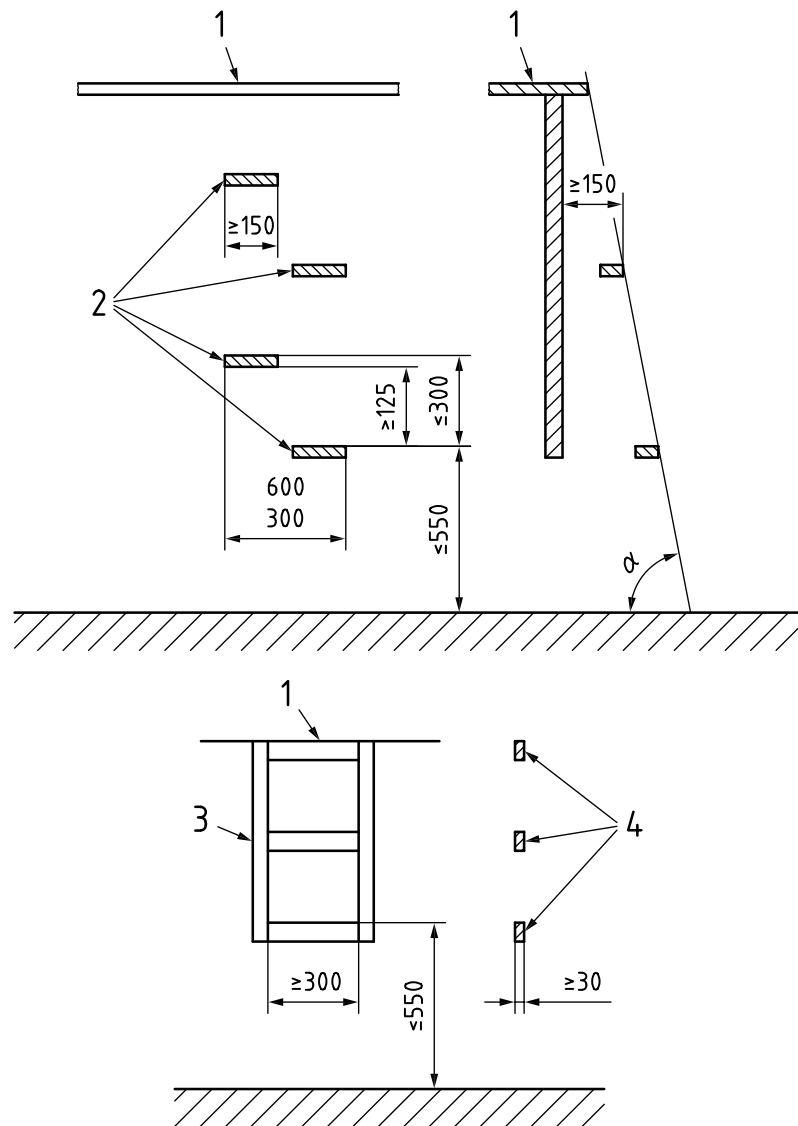

Key

- 1 place to stand
- 2 step
- 3 ladder
- 4 rung

Figure 5 — Dimensions of boarding means for other than operator stations

4.9 Folding elements

4.9.1 Handle(s) located at least 300 mm from the nearest articulation shall be provided for manually folding/unfolding elements. The handle(s) may be integral parts of the machine provided they are suitably designed and clearly identified. The force required for the manual folding/unfolding processes shall not exceed 250 N as an average value when moving from the start to the stop position. The peak(s) shall not exceed 400 N. There shall be no shearing, pinching or uncontrollable movement hazards to the operator during folding/unfolding.

4.9.2 Folded elements designed to reduce transport width and/or height shall have a means of retention in the transport position, either a positive mechanical lock or by other means (e.g. hydraulically, gravity). The means of retention shall be sufficient to retain the folded element in the transport position during travel. The change from transport position to working position and vice versa shall be possible without exposing the operator to crushing and pinching.

In the case of mechanical or hydraulic locking devices, the unlocking and unfolding of the elements shall be controlled by means of separate actions by the operator.

4.9.3 Barriers which exceed the transport width may be folded from the functional/protection position into a transport position. If folding of the barrier(s) exposes hazards, caused by working tools, operation of the hazardous components shall be prevented with the barrier(s) folded (for example by reducing the function or performance of the machine component in this situation).

4.10 Strength requirements for guards and barriers

4.10.1 Guards and barriers, and in particular barriers with a vertical height from the ground of up to 550 mm, whose use as access steps during normal use is not intended by the manufacturer but cannot be prevented, shall be designed so that they can withstand a vertical load of 1 200 N. Conformance with this requirement shall be checked using the test given in [Annex C](#) or an equivalent method which fulfils the same test acceptance criteria.

4.10.2 Barriers used as protection against hazards related to moving working parts shall withstand the following horizontal loads:

- 1 000 N, up to 400 mm from the ground in the working position;
- 600 N, above 400 mm from the ground in the working position.

Conformance with these requirements shall be checked using the test given in [Annex C](#) or an equivalent method.

4.11 Supports for service and maintenance

4.11.1 General

4.11.1.1 When it is necessary for the operator to work under raised parts of the machine in order to carry out maintenance or service, mechanical supports or hydraulic locking devices shall be provided to prevent inadvertent lowering.

Means other than mechanical or hydraulic devices are acceptable, provided an equal or greater level of safety is ensured.

4.11.1.2 It shall be possible to engage and release hydraulic locking devices, mechanical supports and other forms of support from outside the hazard zones.

4.11.1.3 Mechanical supports and hydraulic locking devices shall be identified by use of a colour that contrasts with the overall machine colour or by a safety sign located either on, or in close proximity to, the device.

4.11.1.4 When the supports or hydraulic devices are controlled manually, their method of operation shall be explained in the operator's manual [see 8.2.3 k)] and, if such operation is not intuitive, on the machine itself using either a safety or informational sign.

4.11.2 Mechanical supports

4.11.2.1 Mechanical supporting devices shall withstand a load of 1,5 times the maximum static load to be supported.

4.11.2.2 Detachable mechanical supports shall be retained in position on the machine. If this is not practicable, they shall have a dedicated and clearly visible and identifiable storage position on the machine allowing the safe storage of the support.

4.11.3 Hydraulic locking devices

Hydraulic locking devices shall be located on the hydraulic cylinder or connected to the hydraulic cylinder by rigid or flexible lines. In the latter case, the lines connecting the locking device to the hydraulic cylinder shall be designed to withstand a pressure at least four times the rated maximum hydraulic pressure. This rated maximum hydraulic pressure shall be specified in the operator's manual. The conditions for the replacement of such flexible lines shall also be given in the operator's manual [see 8.2.3 l)].

Inadvertently unlocking shall be avoided by design, location, etc. of the control.

4.12 Electric equipment

4.12.1 Electrical cables shall be protected if located in potentially abrasive contact with surfaces and shall be resistant to, or protected against, contact with lubricant or fuel. Electrical cables shall be located so that no portion is in contact with the exhaust system, moving parts or sharp edges.

4.12.2 Fuses or other overload protection devices shall be installed in all electrical circuits except for the starter-motor circuit and the high-tension spark ignition system. Electrical distribution of these devices between circuits shall prevent the possibility of cutting-off all warning systems simultaneously.

4.13 Hydraulic components and fittings

4.13.1 Hydraulic systems shall comply with the safety requirements of ISO 4413:2010.

4.13.2 Pressurized hoses, pipes and components shall be located or shielded so that in the event of rupture, the fluid cannot be discharged directly onto the operator when in the operating position.

4.13.3 Information on the renewal of hoses shall be provided in the operator's manual [see 8.2.3 l)].

4.14 Pneumatic systems

Pneumatic systems shall comply with the safety requirements of ISO 4414:2010.

4.15 Operating fluids

Any tank filler shall be located not more than 1 500 mm above the ground, a platform or a place to stand. The platform or the place to stand, if provided, shall be in accordance with 4.8.2.

Changing of operating fluids, including the safety aspects, shall be explained in the operator's manual [see 8.2.3 j) and x)].

4.16 Manual operation of individual assemblies

If special tools are required for the manual operation of individual assemblies, these shall be supplied with the machine and their use explained in the operator's manual [see 8.2.3 m)].

4.17 Service and handling of machine parts

4.17.1 The service operations shall be capable of being carried out in a safe way, for example with the power source stopped.

4.17.2 Components which require frequent maintenance shall be accessible by means according to 4.8.

4.17.3 Hinged guards and doors shall be fitted with a means to retain them in the open position, if a hazard from uncontrolled closing exists.

4.17.4 For the parts of the machine that are handled by the operator:

- if their mass is ≥ 40 kg, they shall be designed or fitted with attachments so that the use of lifting equipment is possible;
- if their mass is < 40 kg, they shall be fitted with handles or parts of the machine located so that safe handling is ensured and such that, during this operation, any contact with hazardous parts (cutting tools, hot surfaces, etc.) is prevented.

4.18 Electromagnetic compatibility

Machinery shall comply with ISO 14982:1998.

4.19 Emergency stop

If

- the (main) operator station is located in the direct proximity of a hazard zone for functional reasons, or
- the machine is equipped with additional operator stations which are located in direct proximity of a hazard zone and used during normal operation, or
- controls other than hold to run controls are located in the direct proximity of a hazard zone, or
- the vision or communication between operator stations which are used simultaneously is restricted, or
- machines are operated by the use of remote controls (this means the operator is not at the operator station on the machine),

the main, the additional operator station(s) and the remote control device(s) shall be fitted with emergency stop device(s) to enable actual or impending danger to be averted.

Emergency stop devices – except wireless devices – shall comply with ISO 13850:2006.

NOTE ISO 13850 is not applicable to wireless emergency stop devices.

4.20 Safety-related parts of control systems

Safety-related parts and programmable control systems shall be in accordance with ISO 25119:2010, Parts 1 to 4 or ISO 13849-1:2006 and ISO 13849-2:2012

NOTE Performance levels (or categories) in accordance with ISO 25119 or ISO 13849 can be given in relevant machine-specific standards or parts of ISO 4254.

5 Safety requirements and/or measures — Self-propelled ride-on machines

5.1 Operator station

5.1.1 Access to operator's seat

For access to the operator's seat, the floor area shall have a minimum width of 300 mm. Devices such as rear-view mirrors shall not intrude into the access space in any of their engaged/disengaged positions, except in the case of devices intended to restrict the operator encountering hazards during normal operation.

5.1.2 Operator's seat

5.1.2.1 On machines on which the operator is required to sit, a seat shall be provided which adequately supports the operator in all working and operating modes. Information on the seat adjustment shall be provided in the operator's manual [see [8.2.3 e](#)].

5.1.2.2 The driver's seat dimensions and adjustment shall meet the requirements of ISO 4253, except that the seat index point (SIP) dimension above the platform shall be 500 mm minimum and 650 mm maximum (see [Figure 6](#)). The driver's seat adjustment mechanism(s) shall prevent unintended seat movement and shall have stops at the ends of the adjustment range. The suspension system, if provided, shall be adjustable to accommodate the weight of the driver.

5.1.2.3 If the machine is equipped with a roll-over protective structure (ROPS), the operator's station shall be equipped with a the seat and restraint system that complies with the requirements of ISO 3776-1:2006, ISO 3776-2:2013 and ISO 3776-3:2009.

5.1.3 Propulsion and steering

5.1.3.1 The controls used to activate machine propulsion shall be located or designed so that they can only be operated from the operator's station.

5.1.3.2 Self-propelled machines having automatic steering functions shall comply with the requirements of ISO 10975:2009.

5.1.3.3 The steering mechanism shall be so designed as to reduce the transmission of force to the operator's hand in the event of any sudden movement of the steering-wheel or -lever(s) in reaction to the steered wheel(s).

5.1.3.4 When the steering mechanism is in the operating position, the clearance between the fixed parts and the steering wheel shall be as shown in [Figure 7](#).

For the distance to controls, see [4.5.3](#).

Dimensions in millimetres

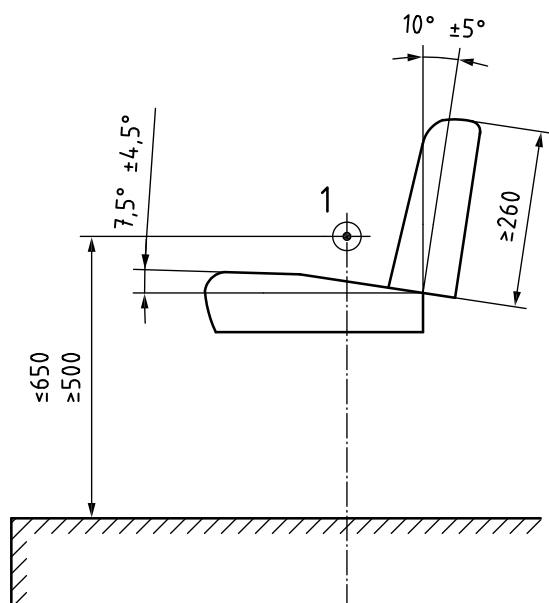

a) Intermediate seat adjustment

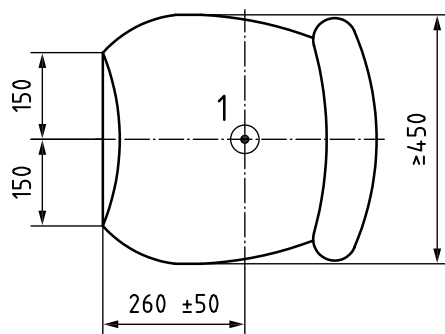

b) Coordinate for measuring width of seat

Key

1 SIP

Figure 6 — Seat dimensions and height

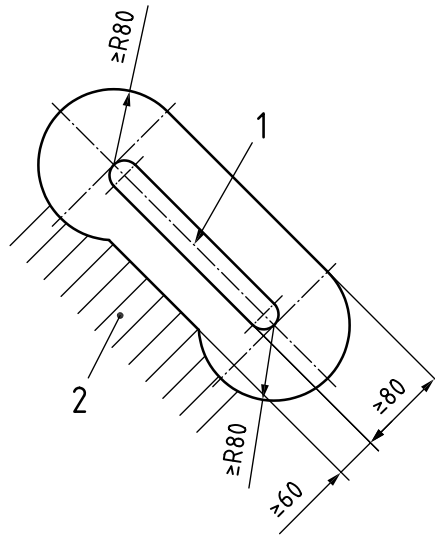
**Key**

- 1 steering wheel
- 2 fixed parts

Figure 7 — Clearance between the steering wheel and fixed parts

5.1.4 Shearing and pinching points

In the operator's workplace, there shall be no shearing or pinching points within hand or foot reach of the operator when seated in the seat provided.

5.1.5 Emergency exit

5.1.5.1 When the operator's station is equipped with a cab, provisions shall be made for an emergency exit. In addition to the primary door, at least one other exit shall be provided as an emergency exit. A second door, windshield(s), roof panel or window(s) not on the same side wall as the primary door is to be considered as an emergency exit, provided that it can be opened or removed quickly from inside the cab. If a special tool is required, this tool shall be attached to the cab and provided for this purpose near the exit.

5.1.5.2 Emergency exits shall

- be of a size to accommodate as a minimum an ellipse with principal axes of 640 mm and 440 mm;
- be labelled with the user instructions if the intended emergency exit is not routinely used or if location and use is not obvious.

If labelling is used, information on location and use shall be located in the cab near the exit and visible to the operator and reproduced in the operator's manual [see 8.2.3 g)]. Such exits include, but are not limited to, a single latch window or a second egress door with a handle and latch.

5.1.6 Cab material burning rate

The burning rate of cab interior material such as seat covering, wall, floor and headliner coverings when provided shall not exceed the maximum rate of 150 mm/min when tested in accordance with ISO 3795:1989.

5.1.7 Visibility

5.1.7.1 The design and position of the operator's station shall be such that the operator has adequate visibility direct or indirect to operate the machine and view the work area of the machine.

5.1.7.2 When the operator's station is equipped with a cab, a windscreen wiper shall be provided.

5.1.7.3 Provisions for installing working lights shall be available.

5.1.8 Starting and stopping the engine

5.1.8.1 To avoid unauthorized activation of the engine starting, means such as the following shall be provided to avoid unauthorized activation:

- key-operated ignition or starting switch;
- lockable cab;
- lockable cover for the ignition or starting switch;
- security ignition or starting lock;
- lockable battery disconnecting switch.

Information to avoid unauthorized starting shall be provided in the operator's manual [see [8.2.3 f](#)].

5.1.8.2 Provisions shall be made to prevent the engine starter, if provided, from engaging unless

- the traction transmission(s) is (are) in the neutral or parked position; or
- the traction clutch is disengaged; and
- the master implement clutch (PTO) is disengaged.

5.1.8.3 Stopping the engine shall be achieved by a device constructed so that

- the engine's stop device does not require sustained manual operation, and
- when the device is set at the "off" or "stop" position, the engine cannot be re-started, unless the device has been reset.

5.2 Moving the machine

5.2.1 Attachments for towing

Attachment points for retrieving and towing (hooks, rings, ears, etc.) shall be provided at the front and/or rear of the machine. If these attachment points are not obvious, they shall be clearly indicated on the machine and in the operator's manual [see [8.2.3 n](#)] and [8.4](#)].

5.2.2 Moveable attachments

Means shall be provided to maintain moveable attachments in their transport position.

5.2.3 Use of lifting jacks

5.2.3.1 Application points for use with jacks when raising the machine shall be clearly marked, if not obvious, and their location and the procedure for using jacks shall be described in the operator's manual [see [8.2.3 n](#)] and [8.4.2](#)].

5.2.3.2 The jack-up points shall have the appropriate strength and be constructed so that a laden machine can be lifted from the ground (e.g. to change the wheels).

5.3 Electric

5.3.1 Batteries shall be located so they can be properly maintained and exchanged, from the ground or a platform, and shall be secured to remain in position and located or constructed and sealed so as to reduce the possibility of spillage in the event of a machine overturn. The electrical, non-earth terminals of batteries shall be protected to prevent unintentional contact and shorting to earth.

5.3.2 It shall be possible to easily disconnect the battery electrical circuit (e.g. without tools, with common tools or a mechanical or electrical switch).

5.3.3 Information on service and replacement of the battery shall be provided in the operator's manual [see [8.2.3 s](#)].

5.4 Fuel tank

5.4.1 Fuel tank filler(s) shall be located outside the cab.

5.4.2 Fuel tanks shall be corrosion-resistant and shall satisfy leakage tests at a pressure equal to double the working pressure, but in any event not less than 30 kPa.

5.4.3 Fuel cap design shall not allow leaking while the engine is at the normal operating temperature and in all machine working positions. Seepage from the fuel tank ventilation system shall not be considered as a leaking condition.

5.4.4 Information on filling of the fuel tank shall be provided in the operator's manual [see [8.2.3 t](#)].

5.5 Hot surfaces

Hot surfaces which can be reached inadvertently by the operator during normal operation of the machine shall be covered or insulated. This requirement applies to hot surfaces which are near steps, handrails, handholds and integral machine parts used as boarding means and which can be inadvertently touched.

5.6 Exhaust gases

The outlet of the exhaust pipe shall be located and directed in such a way that the operator or any other person required on the machine during operation are not normally exposed to harmful concentrations of noxious gases or fumes.

EXAMPLE Location of the outlet away from the head level of the operator or the intake of the cab.

5.7 Roll- and tip-over

The principles for the assessment of stability with respect to hazards associated with roll-over and tip-over specified by ISO 16231-1 shall be applied.

6 Safety requirements and/or measures — Mounted, semi-mounted and trailed machines

6.1 Controls

6.1.1 The control device on the tractor or self-propelled machine for controlling the energy supply to a trailed or mounted machine shall be considered the normal device for stopping the trailed or mounted machine, unless

- it is specified otherwise in a machine-specific part to this standard, or
- there is an operator station on the trailed or mounted machine, or
- an operator position is provided beside the machine for use with the machine operating in a stationary position.

6.1.2 Manual control(s) requiring the operator to stand on the ground while the PTO drive shaft is running shall be situated at a minimum horizontal distance of 550 mm from the PTO drive shaft.

6.2 Stability

6.2.1 General

6.2.1.1 Machines shall be designed to be stable when parked on firm ground, with an inclination up to 8,5° in any direction. This requirement shall be met with any tanks or hoppers empty, and with any tanks or hoppers filled with the product handled by the machine, and in both cases with and without optional fitted equipment or containers for which the machine has been designed.

6.2.1.2 Supporting devices, other than wheels (e.g. stands, outriggers) shall have a bearing surface designed to limit the ground pressure to a maximum of 400 kPa. Outriggers or similar devices shall also be lockable in their transport position. It shall be possible for the driver/operator to verify visually that the outriggers are in the transport position. Appropriate information shall be provided in the operator's manual [8.2.3 o)]

6.2.1.3 If the required stability when in operation or stationary can only be achieved by employing special measures or by using the machine in a particular way, the required procedures shall be marked on the machine and repeated in the operator's manual [8.2.3 i)].

6.2.2 Mounted and semi-mounted machines

6.2.2.1 If a supporting device is necessary for storing the machine, this device shall remain attached to the machine.

6.2.2.2 The height of the lower hitch points of three-point mounted machines shall be compatible with the lower hitch point height of the intended three-point linkage.

NOTE For relevant information, see for example ISO 730,[4] ISO 8759 (all parts),[5] ISO 2332.[6]

6.2.3 Trailled machines with vertical load on draw bar hitch > 500 N

6.2.3.1 Trailers or machines with draw bars designed to be picked up mechanically by the towing vehicle shall be fitted with a stand capable of supporting the draw bar with the hitch point at least 150 mm above the ground (for the maximum ground pressure, see also 6.2.1.2).

6.2.3.2 Trailers or machines with draw bars designed to be coupled to a fixed-height clevis shall be fitted with a supporting device or jack whose height is adjustable and which may be of one or the other of the following types:

- non-folding, in which case the design shall be such that inadvertent movement of the position is not possible;
- folding, in which case the design shall be such that the supporting device can be securely fastened in the transport and supporting positions. The supporting device shall have a manual control located on the left of the machine in relation to the direction of motion. The supporting device shall be lockable (by design or additional means). Supporting or height adjusting the drawbar shall not be possible unless the supporting device is locked.

6.2.3.3 If crushing and shearing points are unavoidable when operating the supporting device, then instructions giving advice on how to avoid such hazards shall be given in the operator's manual [see [8.2.3 u](#)].

6.2.3.4 Supporting devices and their securing elements shall normally be fixed to the machine. If, however, such supporting devices do not permit the proper use of the machine, and providing that their removal does not affect the stability of the machine, then these supporting devices may be made detachable without the use of tools. In this case, suitable instructions shall be given in the operator's manual [see [8.2.3 u](#)]. If supporting devices are detachable, provision shall be made for storing them on the machine.

6.3 Hitches for towing

6.3.1 Appropriate information about the hitching system, including maintenance and checks (including allowed maximum wear), shall be included in the operator's manual [see [8.2.3 a](#)) and b)].

6.3.2 Hitching points for towing the machines shall be clearly shown in the operator's manual which shall also include the maximum static vertical force exerted on the towing vehicle [see [8.2.3 a](#) and b)].

6.4 Transmission of mechanical power between self-propelled machines/tractors and recipient machinery

6.4.1 General

The straight line overlap of the power take-off (PTO) drive shaft guard with the power input connection (PIC) guard shall be not less than 50 mm. This minimum overlap shall also apply to protection devices of wide-angle PTO drive shafts and when using clutches or other elements.

If the operator has to reach between the PTO drive shaft guard and the PIC guard to connect the drive shaft, the clearance in one plane shall be 50 mm min. and in all planes the distance shall not exceed 150 mm (see [Figure 8](#)).

If the machine can be equipped with a PTO drive shaft with a guard, the restraining device of which requires a fixing point on the machine, suitable fixing point(s) shall be provided.

The machine shall be supplied with a support for the transmission shaft when the machine is uncoupled, but this support shall not be the device used to prevent rotation of the transmission shaft guard or damage the guard.

The PIC guard shall be so constructed and attached to the implement that, in conjunction with the PTO drive shaft guard, it encloses the shaft on all sides up to the first fixed-bearing housing of the machine, while allowing for fitting and articulation of the PTO drive shaft.

Information about the adaptation of the PTO drive shaft length shall be provided in the operator's manual [[8.2.3 b](#)].

6.4.2 Stationary operation

PTO-driven equipment designed to operate in a stationary position shall be provided with means to prevent separation of the PTO drive shaft. Information on the use of such means shall be provided in the operator's manual [see 8.2.3 v)].

6.5 Hydraulic, pneumatic and electrical connections with a self-propelled machine or towing vehicle

Suitable devices for supporting disconnected hydraulic and pneumatic hoses and electric cables when the machine is not coupled to a self-propelled machine or towing vehicle or when the connections are not in use shall be provided.

Dimensions in millimetres

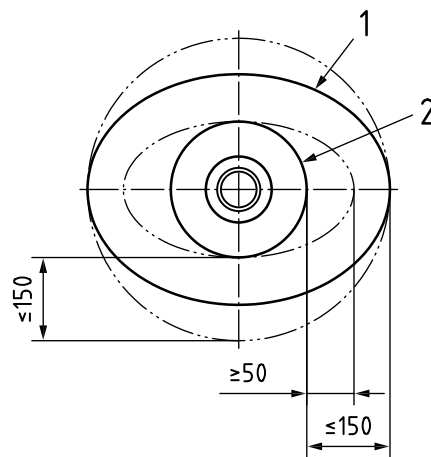

Key

- 1 PIC guard
- 2 PTO drive shaft guard

Figure 8 — Clearance between PIC and PTO drive shaft guard

7 Verification of safety requirements or protective measures

See [Table 2](#).

Table 2 — List of safety requirements and/or protective measurements and their verification

Clause/ sub-clause	Verification		
	Inspection	Measurement	Procedure/reference
4.3	X	X	Shall be verified in accordance with Annex B .
4.7.1.2.	X	X	Shall be verified by operating the boarding means according to the instructions in the operator's manual.
4.9	X	X	Shall be verified by folding the elements in according to instructions in the operator's manual and while using the handles or integral parts identified for that purpose.
4.10.1	X	X	Shall be verified in accordance with Annex C .
4.11.1.1	X	—	Shall be verified by carrying out maintenance or service operations described in the operator's manual.
4.17	X	—	Shall be verified carrying out lubrication and maintenance operations described in the operator's manual.
5.1.2.3	X	—	Shall be verified in accordance with ISO 3776-1, ISO 3776-2 and ISO 3776-3.
5.1.6	X	—	Shall be verified in accordance with ISO 3795.
5.4.2	X	—	Shall be verified by using the manufacturer's specification (30 kPa min).
6.2.1.1	X	X	Shall be verified by using the blocking devices (e.g. chocks), if provided, in place or actuated, and by parking the machine in the manner described in the operator's manual.

8 Information for use

8.1 General

Information for use shall be in accordance with ISO 12100:2010, 6.4.

8.2 Operator's manual

8.2.1 An operator's manual shall be supplied with each machine.

8.2.2 Easily accessible storage place for the operator's manual shall be provided on self-propelled machines.

8.2.3 The operator's manual shall conform to the requirements of ISO 3600:1996, including provision of safety instructions relative to normal operation and servicing of the machine and use of personal protective equipment as appropriate.

In particular, the following information and points shall be included, if relevant:

- a) the correct methods of mounting and dismounting (see [6.3.1](#), [6.3.2](#));
- b) compatibility with the tractors, e.g. hitching system, PTO drive shaft, vertical load at the hitching point, engine power, stability (see [6.3.1](#), [6.3.2](#), [6.4.1](#));
- c) that the weight of mounted machines (including their loads) can influence tractor manoeuvrability and stability and a means of assessing stability ([Annex D](#) provides one means for assessing the stability of the tractor/machine combination);
- d) description and function of all controls including an explanation of the symbols used (see [4.5.1](#));

- e) how to adjust the position of the seat to provide an ergonomic relationship with the controls and to reduce exposure to vibrations (see [5.1.2.1](#));
- f) method of starting and stopping the engine (see [5.1.8](#));
- g) location and method of opening emergency exits (see [5.1.5.2](#));
- h) precautions to be taken with moving parts involved in the working process;
- i) use of supports to ensure stability when parked (see [6.2.1.3](#), [8.4.3](#));
- j) general requirements for servicing and maintaining the machine and usage of special tools (see [4.15](#), [4.17.1](#));
- k) use of devices for maintaining machine parts in a raised position during maintenance and servicing (see [4.11.1.4](#));
- l) provision of information concerning the renewal of hoses used in hydraulic locking systems (see [4.11.3](#), [4.13.3](#));
- m) manual operation of individual parts (see [4.16](#));
- n) information on the correct method for towing and lifting the machine (see [5.2.1](#), [5.2.3.1](#), [8.4.2](#));
- o) information on how to verify that the outriggers are safely stored in the transport position (see [6.2.1.2](#));
- p) hazards associated with overhead power lines, if the maximum working height of the machine is greater than 4,0 m, including specification of the maximum working height;
- q) noise emission values (see [4.3.2](#));
- r) vibration emission values (see [4.4.1](#));
- s) hazards associated with the use of batteries (see [5.3.3](#));
- t) hazards associated with filling of fuel tanks (see [5.4.4](#));
- u) how and where to apply lifting jacks, including the use of jacks and supporting devices on the draw bar (see [6.2.3.3](#), [6.2.3.4](#));
- v) information on the use of means to prevent separation of the PTO drive shaft for PTO-driven equipment designed to operate in a stationary position (see [6.4.2](#));
- w) tyre size(s) and inflation pressure(s) (see [4.7.1.1.1](#), [4.7.1.2.1](#));
- x) instruction how to change operating fluids (see [4.15](#));
- y) additional information:
 - 1) intended use of the machine;
 - 2) initial set-up of the machinery (unless this is to be carried out by the dealer);
 - 3) fire precautions;
 - 4) clearing of blockages linked to material flows/working processes.

NOTE Declarations on noise and vibration emissions may be subject of national or regional legislation.

8.3 Safety and instructional signs

8.3.1 Safety signs shall be appropriately displayed when necessary to alert the operator and others of the risk of personal injury during normal operation and service.

8.3.2 Safety signs shall conform to the requirements of ISO 11684:1995.

8.3.3 Instructional signs relating to equipment operation, servicing and care shall have an appearance, especially in respect of colour, different from that of the safety signs on the equipment.

8.3.4 When parts of a self-propelled machine exceed the height of 4 m during normal operation, a warning sign in the immediate vicinity of the main operator station shall warn about the hazards associated with overhead hazards such as power lines or bridges.

8.4 Marking

8.4.1 Information to be given on the machine shall be marked legibly and indelibly.

NOTE Marking of machinery may be subject of national or regional legislation.

8.4.2 Application points for use with jacks shall be clearly marked on the machine, if not obvious (see [5.2.3.1](#)), and additional information shall be provided in the manual [see [8.2.3 n](#)].

8.4.3 A sign on the machine shall be provided showing which special measures are to be taken or how the machine is to be used to ensure stability, if applicable (see [6.2.1.3](#)) and additional information shall be provided in the operator's manual (see [8.2.3 i](#)).

Annex A (informative)

List of significant hazards

[Table A.1](#) specifies the significant hazards, significant hazardous situations and significant hazardous events that have been identified as being significant to the types of machines covered by this part of ISO 4254 and which require specific action by the designer or manufacturer to eliminate or reduce the risk.

Table A.1 — List of significant hazards, hazardous situations and hazardous events

	Hazard	Hazardous situation/event	Subclause of this part of ISO 4254
A.1	Mechanical hazards		
A.1.1	Crushing hazard	<ul style="list-style-type: none"> — Controls — Boarding means — Platforms — Power transmission — Working tools — Service/maintenance — Roll-over — Shearing/pinching points — Moving the machine — Stability — Mounting of machines 	4.5.3 ; 5.1.3.2 ; 5.1.8 ; 6.1 4.7.1.1.2 ; 4.7.1.2.5 ; 4.7.2 ; 4.8 4.7.2 6.4 4.10 4.11 ; 4.17.1 ; 4.17.3 ; 4.9.2 ; 4.9.3 5.1.2.3 ; 5.7 5.1.4 5.2 6.2 6.2.2 ; 6.2.3 ; 6.3
A.1.2	Shearing hazard	<ul style="list-style-type: none"> — Controls — Boarding means — Platforms — Power transmission — Working tools — Service/maintenance — Roll-over — Shearing/pinching points — Moving the machine — Stability — Mounting of machines 	4.5.3 ; 5.1.3.2 ; 5.1.8 ; 6.1 4.7.1.1.2 ; 4.7.1.2.5 ; 4.7.2 ; 4.8 4.7.2.2 6.4 4.10 4.11 ; 4.17.1 ; 4.17.3 ; 4.9.2 ; 4.9.3 5.1.2.3 ; 5.7 5.1.4 5.2 6.2 6.2.2 ; 6.2.3 ; 6.3
A.1.3	Cutting or severing hazard	— Working tools	4.9.2 ; 4.9.3
A.1.4	Entanglement hazard	<ul style="list-style-type: none"> — Power transmission — Working tools — Starting/stopping the engine 	6.4 4.9.2 ; 4.9.3 5.1.8
A.1.5	Drawing-in or trapping hazard	<ul style="list-style-type: none"> — Power transmission — Working tools — Starting/stopping the engine 	6.4 4.9.2 ; 4.9.3 5.1.8
A.1.6	Impact hazard	<ul style="list-style-type: none"> — Boarding means — Folding elements — Steering 	4.7.1.2.5 4.9.2 ; 4.9.3 5.1.3.1
A.1.7	Stabbing or puncture hazard	— Working tools	4.9.2 ; 4.9.3
A.1.8	Friction or abrasion hazard	<ul style="list-style-type: none"> — Controls — Electrical equipment — Boarding means 	4.5.3 ; 5.1.3.2 4.12 4.7.1.1.2
A.1.9	High-pressure fluid injection or ejection hazard	— Hydraulic components	4.13 ; 6.5
A.2	Electrical hazards		
A.2.1	Contact of persons with live parts (direct contact)	— Electrical equipment	4.12 ; 5.3 ; 6.5

Table A.1 (continued)

	Hazard	Hazardous situation/event	Subclause of this part of ISO 4254
A.2.2	Contact of persons with parts which have become live under faulty conditions (indirect contact)	— Electrical equipment	4.12.1
A.2.3	Approach to live parts under high voltage	— Overhead power lines	8.2.3 ; 8.3.4
A.2.4	Thermal radiation or other phenomena such as the projection of molten particles and chemical effects from short circuits, overloads, etc.	— Electrical equipment	4.12.2 ; 5.3.1
A.2.5	Electromagnetic phenomena	— Electrical equipment	4.18
A.3	Thermal hazards		
	Burns, scalds and other injuries by possible contact of persons with objects or materials with an extreme high or low temperature, by flames or explosions and also by the radiation of heat sources	— Operating fluids — Cab material — Hot surfaces	4.15 5.1.6 5.5
A.4	Hazards generated by noise		
	Hearing loss (deafness), other physiological disorders (e.g. loss of balance, loss of awareness) Accidents due to interference with speech communication and acoustic warning signals	— Noise	4.3
A.5	Vibration hazards		
A.5.1	Discomfort, low-back morbidity	— Machine design — Seat	4.4 5.1.2
A.6	Hazards generated by materials and substances		
A.6.1	Hazards from contact with, or inhalation, of harmful fluids, gases, mists, fumes and dusts	— Operating fluids — Cab material — Battery — Exhaust gases	4.15 ; 5.4 5.1.6 5.3.1 5.6
A.6.2	Fire or explosion hazard	— Cab material	5.1.6
A.7	Hazards generated by neglecting ergonomic principles in machinery design		
A.7.1	Unhealthy postures or excessive effort	— Controls — Boarding means — Service and maintenance — Operator station	4.5 4.7 ; 4.8 4.11 ; 4.17.4 5.1.1 ; 5.1.3 ; 5.1.5.2
A.7.2	Inadequate consideration of hand-arm or foot-leg anatomy	— Controls — Boarding means — Operator station	4.5 4.7 ; 4.8 5.1
A.7.3	Neglected use of personal protective equipment	— Operator's manual	8.2.3
A.7.4	Inadequate local lighting	— Visibility	5.1.7.3
A.7.5	Mental overload and under load, stress	— Controls	4.5
A.7.6	Human error, human behaviour	— Controls — Operator's manual — Signs	4.5 8.2 8.3
A.7.7	Inadequate design, location or identification manual controls	— Controls	4.5 ; 5.1.3 ; 6.1
A.8	Combination of hazards	— Individual assemblies — Operator's manual	4.16 8.1 ; 8.2

Table A.1 (continued)

	Hazard	Hazardous situation/event	Subclause of this part of ISO 4254
A.9	Unexpected start-up, unexpected overrun/overspeed		
A.9.1	Failure/disorder of the control system	— Service and maintenance — Electrical equipment — Connections	4.11 4.12 6.5
A.9.2	Restoration of energy supply after an interruption	— Controls	4.5 ; 6.1
A.9.3	External influences on electrical equipment	— Cables	4.12.1
A.9.4	Other external influences (gravity, wind, etc.)	— Stability	6.2.1.1 ; 6.2.1.2
A.9.5	Errors made by the operator (due to mismatch of machinery with human characteristics and abilities)	— Controls — Boarding means — Operator station — Moving the machine — Mounting of machines — Service and maintenance — Operator's manual	4.5 ; 6.1.2 4.7 ; 4.8 5.1 5.2 6.2 ; 6.3 4.17 8.2.3
A.10	Impossibility of stopping the machine in the best possible conditions	— Controls — Starting/stopping the engine	4.5 ; 4.19 ; 6.1 5.1.8
A.11	Variations in the rotational speed of tools	— PTO drive shaft	6.4 ; 8.1 ; 8.2
A.12	Failure of power supply	— Supports — Electrical equipment — Connections	4.11 4.12 6.5
A.13	Failure of the control circuit	— Electrical equipment	4.12 ; 4.20
A.14	Errors of fitting	— Mounting of machines — Operator's manual	6.2 ; 6.3 8.1 ; 8.2
A.15	Break-up during operation	— Guards and barriers — Supports — Hydraulic components — Pneumatic components	4.10 4.11 4.13 4.14
A.16	Falling or ejected objects or fluids	— Supports — Hydraulic components — Folding elements	4.11 4.13 4.9.2 ; 4.9.3
A.17	Loss of stability/overtipping of machinery	— Stability — Roll-over	6.2 5.1.2.3 ; 5.7
A.18	Slip, trap and fall of persons (related to machinery)	— Boarding means	4.7 ; 4.8
Additional hazards, hazardous situations and hazardous events due to mobility			
A.19	Related to the travelling function		
A.19.1	Movement when starting the engine	— Propulsion of machine — Starting/stopping the engine	5.1.2.3 5.1.8
A.19.2	Moving without a driver at the driving position	— Propulsion of machine — Starting/stopping the engine	5.1.3 5.1.8
A.19.3	Movement without all parts in a safe position	— Folding elements	4.9.2 ; 4.9.3
A.19.4	Insufficient ability of machinery to be slowed down, stopped and immobilized	— Propulsion of machine	5.1.3
A.20	Link to the work position		
A.20.1	Fall of persons during access to (or at/from) the work position	— Boarding means	4.7 ; 4.8

Table A.1 (continued)

	Hazard	Hazardous situation/event	Subclause of this part of ISO 4254
A.20.2	Exhaust gases/lack of oxygen at the work position	— Gases	5.4.1 ; 5.6
A.20.3	Fire (flammability of the cab, lack of extinguishing means)	— Cab material	5.1.6
A.20.4	Mechanical hazards at the working position: a) contact with wheels; b) rollover; c) fall of objects, penetration by objects;	— Shearing/pinching points — Wheels — PTO drive shaft — Supports — Roll-over	4.5.3 ; 4.7.1.2.5 ; 5.1.4 4.7.1.1.2 4.8.2.3 4.11 5.1.2.3 ; 5.7
A.20.5	Insufficient visibility from the work positions	— Visibility	5.1.7
A.20.6	Inadequate lighting	— Visibility	5.1.7.3
A.20.7	Inadequate seating	— Operator's seat	5.1.2
A.20.8	Noise at work position	— Operator's work station	4.3
A.20.9	Insufficient means for evacuation/emergency exit	— Emergency exit	5.1.5
A.21	Due to the control system		
A.21.1	Inadequate location of manual controls	— Controls	4.5 ; 4.11.1.2 ; 5.1.2.1 ; 6.1.1 ; 6.1.2
A.21.2	Inadequate design of manual controls and their mode of operation	— Controls	4.5 ; 5.1.3 ; 5.1.8
A.22	From handling the machine (lack of stability)	— Stability — Roll-over	6.2 5.1.2.3 ; 5.7
A.23	Due to the power source and to the transmission of power		
A.23.1	Hazards from the engine and the batteries	— Starting/stopping the engine — Battery	5.1.8 5.3
A.23.2	Hazards from transmission power between machines	— Power transmission	6.4
A.23.3	Hazards from coupling and towing	— Mounting of machines	6.2.2 ; 6.2.3 ; 6.3
A.24	From/to third persons		
A.24.1	Unauthorized start-up and use	— Starting/stopping the engine	5.1.8.1
A.24.2	Lack or inadequacy of visual or acoustic warning means	— Visibility	5.1.7
A.25	Insufficient instructions for the driver/operator	— Operator's manual	8.1 ; 8.2

Annex B (normative)

Noise test code (engineering method grade 2)

B.1 Scope

This annex provides all the information necessary for carrying out efficiently, and under standardized conditions, the measurement of noise emission values. Use ensures the reproducibility of the determination of noise emission values within specified limits determined by the grade of accuracy of the basic noise standard for the determination of noise emission values used. Methods for the determination of these noise emission values according to this are engineering methods (Grade 2).

B.2 Emission sound pressure levels at the operator's station

B.2.1 Emission sound pressure levels shall be measured in accordance with ISO 11201:2010 or ISO 11204:2010. ISO 11204:2010 shall be used with engineering method Grade 2.

B.2.2 A-weighted time-averaged sound pressure level shall be determined at the operator's station.

For low-noise design, noise emission values in frequency bands are useful and the basic standards ISO 3744 and ISO 11201 may be used for determining noise emission quantities in frequency bands.

B.2.3 With the operator absent, the microphone shall be mounted at a height of $1,60\text{ m} \pm 0,05\text{ m}$ in the position where the operator would normally stand or at a height of $0,50\text{ m} \pm 0,05\text{ m}$ measured in comparison with the seat index point (SIP) and with the seat adjusted in its average position.

B.2.4 When it is necessary for the operator to be present in order to carry out the test, the microphone shall be head-mounted $20,0\text{ cm} \pm 2,0\text{ cm}$ from the median plane of the head on the louder side and in line with the eyes. Standing operators shall be $1,75\text{ m} \pm 0,05\text{ m}$ tall, including shoes. Overall operator height when seated shall be $0,93\text{ m} \pm 0,05\text{ m}$ measured from the plane of the seat's cushion.

B.2.5 The specific noise test code dealing with a particular type of machine shall indicate whether the measurements have to be made without the operator according to B.2.3 or with an operator according to B.2.4.

B.2.6 For those machines driven by an external power source and where the workstation is located on another machine (e.g. a tractor), the microphone shall be mounted according to the method of attachment:

- a) in the case of a three-point linkage, in the vertical plane passing by the middle of the segment joining the two lower points, $1,69\text{ m}$ forward and $1,85\text{ m}$ above the intersection between the plane and this segment;
- b) in the case of a hitch ring, in the vertical plane passing through the centre of the hitch ring $1,20\text{ m}$ forward and $1,85\text{ m}$ above the intersection between the plane and this centre.

B.3 Sound power level determination

B.3.1 The preferred method for determining sound power is that prescribed in ISO 3744:2010. ISO 9614 (all parts) (see Reference[Z]) with Grade 2 accuracy may also be used.

For low-noise design, noise emission values in frequency bands are useful and the basic standards ISO 3744:2010 and ISO 11201:2010 may be used for determining noise emission quantities in frequency bands.

B.3.2 When using ISO 3744, ten microphones shall be used on a hemispherical surface (see ISO 3744:2010, [Annex B](#)).

Alternatively, six microphones may be used, providing that preliminary investigations have shown that the resulting sound power level value is within ± 1 dB of that determined with the array prescribed according to ISO 3744:2010, 8.1.1.

B.3.3 The hemisphere radius shall be at least twice the longest side of the reference parallelepiped: it shall be 4 m or 10 m or 16 m.

B.3.4 The value to be determined is the A-weighted sound power level over a specified work cycle of the machine.

B.3.5 When an operator has to be present during these measurements, the standing operator shall be $1,75 \text{ m} \pm 0,05 \text{ m}$ tall including shoes. Overall operator height when seated shall be $0,93 \text{ m} \pm 0,05 \text{ m}$ measured from the plane of the seat's cushion.

B.4 Installation and mounting conditions

B.4.1 The installation and mounting conditions shall be the same for determination of sound power levels and emission sound pressure levels at specified positions.

B.4.2 Each machine under test shall be standing or supported on a hard reflecting surface, e.g. asphalt or concrete, and on the standard mounts recommended by the manufacturer, e.g. tyres, tracks, stands or vibration mounts. The operator shall be present at the work-station if needed to ensure the operation of the machine in the conditions specified in B.5. The completed data sheet according to B.8 shall indicate if the operator was present during measurements.

B.4.3 Machines powered by an external source shall be powered by a power source sufficient to obtain the operating conditions specified in B.5. The noise level of this power source shall be compatible with the acceptance criteria for the background noise. The evaluation of the background noise shall be carried out when this source is operating without load at a speed equal to that selected for the driving of the machine during the measurement. The acceptance criteria for the background noise level shall be in accordance with ISO 3744:2010 and ISO 11201:2010 engineering Grade 2.

B.5 Operating conditions

B.5.1 The operating conditions are strictly the same for the determination of both sound power levels and emission sound pressure levels at specified stations.

B.5.2 Unless otherwise specified in specific standards, all machines shall be stationary with the tools operating, unloaded, idling at the manufacturer's maximum rated engine speed. The machine shall be properly warmed up and stabilized at the normal operating temperature before testing starts.

Adjustments should be made to ensure that no tools, e.g. blade cutters or blocks, cause additional noise through unintentional mechanical contact.

B.5.3 In the case of machines with work cycles, the noise emission values shall be determined on a complete working cycle. The relevant cycle shall be the one described in the specific standard if one exists. In the absence of such a specific standard, the manufacturer shall choose a work cycle and describe it in the test report.

B.6 Measurement uncertainties

B.6.1 Tests shall be repeated to attain the required grade of accuracy, and until three consecutive A-weighted results give values within 2 dB.

B.6.2 Unless otherwise stated:

- the measurement uncertainty of the determination of A-weighted sound power levels using this part of ISO 4254 shall be that specified in ISO 3744:2010;
- the measurement uncertainty of the determination of A-weighted emission sound pressure levels at work stations using this part of ISO 4254 shall be according to ISO 11201:2010 and ISO 11204:2010 (value of the standard deviation of reproducibility equal to 2,5 dB).

B.7 Information to be recorded and reported

B.7.1 The information to be recorded and reported is that required by the basic standards used for determining the noise emission quantities.

B.7.2 The data sheet according to B.8 shall be used to report key data, in particular the reference of the standards that have been used, the description of the mounting and operating conditions and possible deviations from the noise test code requirements. Operator station locations and the emission sound pressure level at these positions shall be reported. The value of the sound power level shall be reported if determined.

B.7.3 The data sheet and the test report shall also confirm that all requirements of this noise test code have been fulfilled or, alternatively, identify any deviations and list the justification for those necessary deviations.

NOTE Requirements concerning the information about the measurement uncertainty may be the subject of machine-specific parts of ISO 4254.

B.8 Data sheet and test report form

Machine:

Model:

Type:

Rated speed, engine, tool, other:

Dimensions: L..... W..... H.....

Power source:Internal External PTO Hydraulic Diesel Electric Petrol Other **Mounting conditions**Tyres Tracks Stand Vib. mounts Other **Measurement position** - all workstations:**Plan showing measurement position****Emission sound pressure level at work station** L_{pA} in dB:1 2 3

Arithmetic mean of the two highest levels: dB

Sound power level

Radius of hemispherical measurement surface: m

Microphone position:

 L_{WA} in dB:1 2 3

Arithmetic mean of the two highest levels: ... dB

Standards used:

- basic standard for measuring the emission sound pressure level at the operator's station (indicate ISO number);
- basic standard for measuring the sound power level, if determined (indicate ISO number);
- [Annex B](#) of this part of ISO 4254;
- the part of ISO 4254 that deals with the specific machinery type concerned.

Annex C (normative)

Strength tests

C.1 Guards

C.1.1 Test equipment

The load is applied by means of a pad covered with a rubber layer. The dimensions of the pad and the thickness of the rubber layer shall be according to [Figure C.1](#).

The rubber layer shall have a hardness of approximately 20 Shore A.

Dimensions in millimetres (tolerance ± 2 mm)

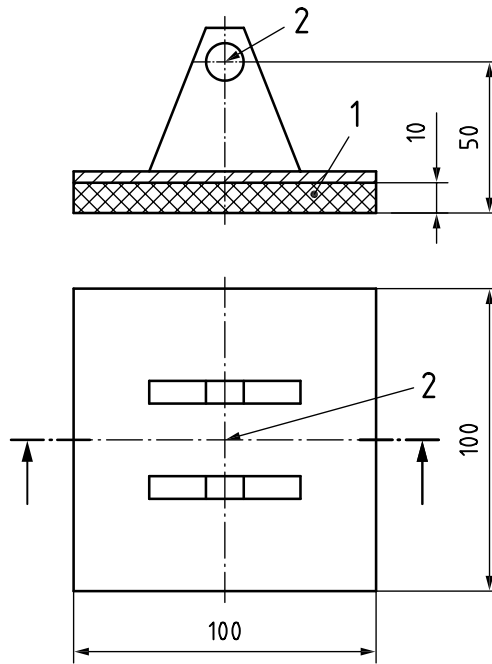

Key

- 1 rubber layer
- 2 application point of the load

Figure C.1 — Example of test pad for guards

C.1.2 Test procedure

The test shall be carried out with the machine parked on a hard horizontal surface.

The guard shall be tested by applying the test load of 1 200 N at the point of the test pad indicated in [Figure C.1](#), vertically even if the guard is not horizontal.

Place the pad on the guard area to be tested, having placed the guard in its protective position on the machine. The vertical downward load is applied without dynamic effect.

The load shall be applied on the most unfavourable areas where an operator could climb. On the edges of the guard, the pad may be partly applied, its application point being near the guard edge.

C.1.3 Test acceptance

During the test, the guard shall not come in contact with the moving parts. At the end of the test, the guard and its attachments shall not be broken, cracked, nor have obvious permanent deformation which would make the guard unable to fulfil its protective function.

C.2 Barriers

C.2.1 Test equipment

The load shall be applied by means of a pad covered with a rubber layer whose dimensions shall be according to [Figure C.2](#).

The rubber layer shall be at least 10 mm thick and have a hardness of approximately 20 Shore A.

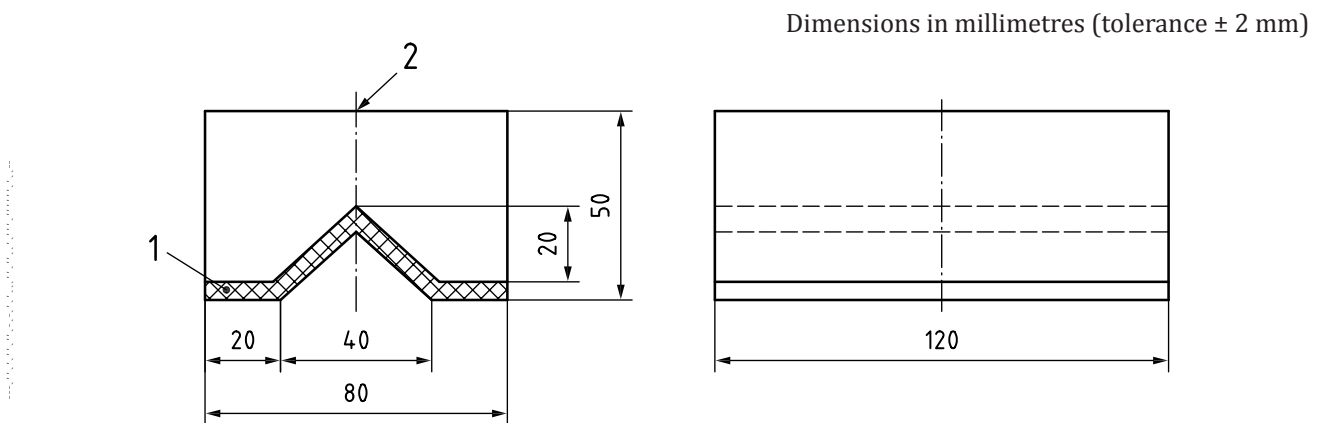

Key

- 1 rubber layer
- 2 application point of load

Figure C.2 — Example of test pad for barriers

C.2.2 Test procedure

Place the pad on the barrier area to be tested. Apply a horizontal and, when applicable, a vertical downward load without dynamic effect.

The barrier shall be tested by applying the test load of

- 1 000 N in the case of barriers 400 mm from the ground in the working position,
- 600 N in the case of barriers above 400 mm from the ground in the working position,

at the point of the test pad indicated in [Figure C.2](#).

C.2.3 Test acceptance

During the test, the barrier shall not move more than 20 mm horizontally. At the end of the test, the barrier and its attachments shall not be broken, cracked, nor have permanent deformation greater than 10 mm. The barrier shall not encroach into the hazard zone.

Annex D (informative)

Stability of tractor machine combinations

This annex is related to [8.2.3 c\)](#), in which there is the requirement to give information concerning the possible loss of stability of the tractor due to the fitting of a machine.

The following text is a suggestion to the manufacturer to enable provision of adequate and complete information to be given.

The example suggested refers to a machine mounted on a tractor.

Due to the mass of the (mounted) machine itself and loaded materials (for example in the hopper), the tractor machine combination can become unstable. In order to verify the total stability, the following expression can be applied for the calculation of the minimum ballasting at the front $I_{F,min}$, which allows to have a load on the front axle equal to 20 % of the unladen mass of the tractor:

$$I_{F,min} = \frac{(I_R \times (c + d)) - (T_F \times b) + (0,2 \times T_E \times b)}{a + b}$$

NOTE Rear-mounted implement and front/rear combinations are considered for this calculation. (See [Figure D.1.](#))

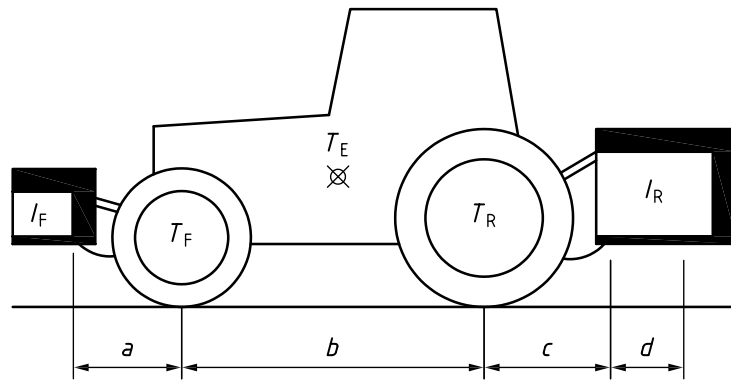

Key

- T_E [kg] mass of unladen tractor
- T_F [kg] front axle load of unladen tractor
- T_R [kg] rear axle load of unladen tractor
- I_R [kg] combined mass of rear-mounted implement/rear ballast
- I_F [kg] combined mass of front-mounted implement/front ballast
- a [m] distance from centre of gravity for combined front-mounted implement/front ballast to front axle centre
- b [m] tractor wheelbase
- c [m] distance from rear axle centre to centre of lower link balls
- d [m] distance from centre of lower link balls to centre of gravity for combined rear-mounted implement/rear ballast

- ①
- ①
- ①
- ②
- ②
- ② ③
- ① ③
- ① ③
- ②

- ① See instruction handbook of the tractor.
- ② See operator's manual of the implement.
- ③ To be measured.

Figure D.1 — Stability of the tractor implement combination

Bibliography

- [1] ISO 26322 (all parts), *Tractors for agriculture and forestry — Safety*
- [2] ISO 19472, *Machinery for forestry — Winches — Dimensions, performance and safety*
- [3] ISO/TR 11688-2, *Acoustics — Recommended practice for the design of low-noise machinery and equipment — Part 2: Introduction to the physics of low-noise design*
- [4] ISO 730, *Agricultural wheeled tractors — Rear-mounted three-point linkage — Categories 1N, 1, 2N, 2, 3N, 3, 4N and 4*
- [5] ISO 8759 (all parts), *Agricultural wheeled tractors — Front-mounted equipment*
- [6] ISO 2332, *Agricultural tractors and machinery — Connection of implements via three-point linkage — Clearance zone around implement*
- [7] ISO 9614 (all parts), *Acoustics — Determination of sound power levels of noise sources using sound intensity*

.....

