

INTERNATIONAL
STANDARD

ISO
4231

Third edition
2016-10-15

**Hand- and machine-operated circular
screwing dies for parallel pipe
threads — G series**

*Filières rondes de filetage, à main et à machine, pour filetages
cylindriques de tuyauterie — Série G*



Reference number
ISO 4231:2016(E)

© ISO 2016



COPYRIGHT PROTECTED DOCUMENT

© ISO 2016, Published in Switzerland

All rights reserved. Unless otherwise specified, no part of this publication may be reproduced or utilized otherwise in any form or by any means, electronic or mechanical, including photocopying, or posting on the internet or an intranet, without prior written permission. Permission can be requested from either ISO at the address below or ISO's member body in the country of the requester.

ISO copyright office
Ch. de Blandonnet 8 • CP 401
CH-1214 Vernier, Geneva, Switzerland
Tel. +41 22 749 01 11
Fax +41 22 749 09 47
copyright@iso.org
www.iso.org

Contents

Page

Foreword	iv
1 Scope	1
2 Dimensions	1
3 Marking	2
Annex A (informative) Relationship between designations in this International Standard and ISO 13399	3
Bibliography	4

Foreword

ISO (the International Organization for Standardization) is a worldwide federation of national standards bodies (ISO member bodies). The work of preparing International Standards is normally carried out through ISO technical committees. Each member body interested in a subject for which a technical committee has been established has the right to be represented on that committee. International organizations, governmental and non-governmental, in liaison with ISO, also take part in the work. ISO collaborates closely with the International Electrotechnical Commission (IEC) on all matters of electrotechnical standardization.

The procedures used to develop this document and those intended for its further maintenance are described in the ISO/IEC Directives, Part 1. In particular the different approval criteria needed for the different types of ISO documents should be noted. This document was drafted in accordance with the editorial rules of the ISO/IEC Directives, Part 2 (see www.iso.org/directives).

Attention is drawn to the possibility that some of the elements of this document may be the subject of patent rights. ISO shall not be held responsible for identifying any or all such patent rights. Details of any patent rights identified during the development of the document will be in the Introduction and/or on the ISO list of patent declarations received (see www.iso.org/patents).

Any trade name used in this document is information given for the convenience of users and does not constitute an endorsement.

For an explanation on the meaning of ISO specific terms and expressions related to conformity assessment, as well as information about ISO's adherence to the World Trade Organization (WTO) principles in the Technical Barriers to Trade (TBT) see the following URL: www.iso.org/iso/foreword.html.

The committee responsible for this document is ISO/TC 29, *Small tools*, Subcommittee SC 9, *Tools with defined cutting edges, cutting items*.

This third edition cancels and replaces the second edition (ISO 4231:1987), of which it constitutes a minor revision with the following changes:

- [Annex A](#) has been added;
- a Bibliography has been added.

Hand- and machine-operated circular screwing dies for parallel pipe threads — G series

1 Scope

This International Standard is a supplement to ISO 2568 and ISO 4230 and specifies the dimensions of hand- and machine-operated circular screwing dies intended for production of parallel pipe threads, G series, in accordance with ISO 228-1.

The general dimensions of these dies (diameter, thickness and fixing dimensions) are in accordance with ISO 2568 so as to permit the driving of hand-operated dies with the aid of the die stocks defined in that document.

2 Dimensions

The general dimensions are shown in [Figure 1](#) and given in [Table 1](#).

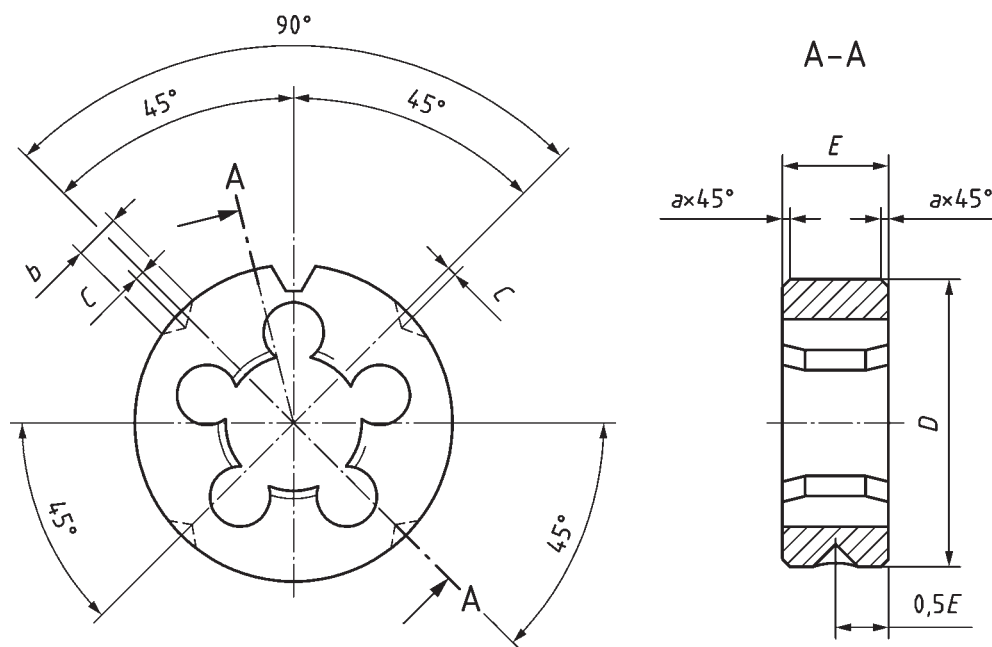

Figure 1

Table 1

Dimensions in millimetres

Thread designation	Basic diameter	Pitch \approx	D	E	C	b	a
1/16	7,723	0,907	25	9	0,8	5	0,5
1/8	9,728	0,907	30	11	1	5	1
1/4	13,157	1,337	38	10	1,2	6	1
3/8	16,662	1,337	45	14	1,2	6	1
1/2	20,955	1,814	45	14	1,2	6	1
5/8	22,911	1,814	55	16	1,5	8	1

Table 1 (continued)

Thread designation	Basic diameter	Pitch ≈	<i>D</i>	<i>E</i>	<i>C</i>	<i>b</i>	<i>a</i>
3/4	26,441	1,814	55	16	1,5	8	1
7/8	30,201	1,814	65	18	1,8	8	1
1	33,249	2,309	65	18	1,8	8	1
1 1/4	41,91	2,309	75	20	1,8	8	2
1 1/2	47,803	2,309	90	22	2	8	2
1 3/4	53,746	2,309	105	22	2,5	10	2
2	59,614	2,309	105	22	2,5	10	2
2 1/4	65,71	2,309	120	22	2,5	10	2

NOTE 1 The shape of the V-groove and the clearance holes are left to the manufacturer's discretion.

NOTE 2 Tolerances:

- for precision screwing dies:
 - on *D*: f10;
 - on *E*: js12;
- for non-precision screwing dies:
 - on *D* and *E*: the tolerances are left to the manufacturer's discretion.

3 Marking

Dies in accordance with this International Standard shall be marked with the letter G, immediately followed by the designation of the thread.

EXAMPLE A G series parallel thread screwing die with designation 3/8 is marked as follows:

G 3/8

Where tools comply in all respects with the relevant International Standards, the Symbol ISO may be appended to the mark at the discretion of the manufacturer.

Annex A (informative)

Relationship between designations in this International Standard and ISO 13399

For the relationship between the designations in this International Standard and preferred symbols according to ISO 13399, see [Table A.1](#).

Table A.1 — Relationship between designations in this International Standard and ISO 13399

Symbol in this International Standard	Reference in this International Standard	Property name in the ISO 13399 series	Symbol in the ISO 13399 series	Reference in the ISO 13399 series
Thread designation	Table 1	Thread diameter, inch measure	TDIN	726E3EA9B08AD
<i>D</i>	Figure 1 Table 1	Body diameter	BD	71ED6A9AF7D1D
<i>E</i>	Figure 1 Table 1	Overall length	OAL	71D078EB7C086
Pitch	Table 1	Thread pitch	TP	71CEAEC08D4B0

Bibliography

- [1] ISO 228-1, *Pipe threads where pressure-tight joints are not made on the threads — Part 1: Dimensions, tolerances and designation*
- [2] ISO 2568, *Hand- and machine-operated circular screwing dies and hand-operated die stocks*
- [3] ISO 4230, *Hand- and machine-operated circular screwing dies for taper pipe threads — R series*
- [4] ISO 13399 (all parts), *Cutting tool data representation and exchange*

