**Assembly tools for screws and nuts —
Single-head engineer's wrenches for
lower torque applications — Maximum
outside dimensions of heads and test
torques**

*Outils de manœuvre pour vis et écrous — Clés à fourche simples
pour applications aux couples plus faibles — Dimensions extérieures
maximales d'encombrement des têtes et couples d'essai*



PDF disclaimer

This PDF file may contain embedded typefaces. In accordance with Adobe's licensing policy, this file may be printed or viewed but shall not be edited unless the typefaces which are embedded are licensed to and installed on the computer performing the editing. In downloading this file, parties accept therein the responsibility of not infringing Adobe's licensing policy. The ISO Central Secretariat accepts no liability in this area.

Adobe is a trademark of Adobe Systems Incorporated.

Details of the software products used to create this PDF file can be found in the General Info relative to the file; the PDF-creation parameters were optimized for printing. Every care has been taken to ensure that the file is suitable for use by ISO member bodies. In the unlikely event that a problem relating to it is found, please inform the Central Secretariat at the address given below.



COPYRIGHT PROTECTED DOCUMENT

© ISO 2009

All rights reserved. Unless otherwise specified, no part of this publication may be reproduced or utilized in any form or by any means, electronic or mechanical, including photocopying and microfilm, without permission in writing from either ISO at the address below or ISO's member body in the country of the requester.

ISO copyright office
Case postale 56 • CH-1211 Geneva 20
Tel. + 41 22 749 01 11
Fax + 41 22 749 09 47
E-mail copyright@iso.org
Web www.iso.org

Published in Switzerland

Foreword

ISO (the International Organization for Standardization) is a worldwide federation of national standards bodies (ISO member bodies). The work of preparing International Standards is normally carried out through ISO technical committees. Each member body interested in a subject for which a technical committee has been established has the right to be represented on that committee. International organizations, governmental and non-governmental, in liaison with ISO, also take part in the work. ISO collaborates closely with the International Electrotechnical Commission (IEC) on all matters of electrotechnical standardization.

International Standards are drafted in accordance with the rules given in the ISO/IEC Directives, Part 2.

The main task of technical committees is to prepare International Standards. Draft International Standards adopted by the technical committees are circulated to the member bodies for voting. Publication as an International Standard requires approval by at least 75 % of the member bodies casting a vote.

Attention is drawn to the possibility that some of the elements of this document may be the subject of patent rights. ISO shall not be held responsible for identifying any or all such patent rights.

ISO 4229 was prepared by Technical Committee ISO/TC 29, *Small tools*, Subcommittee SC 10, *Assembly tools for screws and nuts, pliers and nippers*.

This second edition cancels and replaces the first edition (ISO 4229:1977), Table 1 and Table 2 of which have been technically revised by completion of the width across flats with gaps from 7 mm to 120 mm, in accordance with ISO 272, and by specifying the calculation of the torque test values. In addition, two clauses on designation and marking have been added.

Assembly tools for screws and nuts — Single-head engineer's wrenches for lower torque applications — Maximum outside dimensions of heads and test torques

1 Scope

This International Standard specifies characteristics of single-head engineer's wrenches with gaps from 7 mm to 120 mm, listed in ISO 1703 under the reference Nos. 1 1 01 01 0 and 1 1 01 01 1. The “lower torque application” designation is in accordance with the smaller head dimensions.

Essentially, this International Standard establishes the first specifying maximum outside dimensions of heads and gives the test torque values, which are calculated on the basis of approximately half the values, in accordance with ISO 1711-1, series C.

2 Normative references

The following referenced documents are indispensable for the application of this document. For dated references, only the edition cited applies. For undated references, the latest edition of the referenced document (including any amendments) applies.

ISO 272, *Fasteners — Hexagon products — Widths across flats*

ISO 691, *Assembly tools for screws and nuts — Wrench and socket openings — Tolerances for general use*

ISO 1711-1, *Assembly tools for screws and nuts — Technical specifications — Part 1: Hand-operated wrenches and sockets*

3 Maximum outside dimensions of heads

The maximum outside dimensions of heads are given in Figure 1 and Table 1. Figure 1 does not necessarily indicate the shape of the wrench heads.

4 Technical specifications

4.1 Hardness

After heat treatment, the hardness of the wrenches shall be at least 36 HRC, in accordance with ISO 1711-1.

4.2 Test torques

When tested with the test torques given in Table 2, in accordance with the procedure specified in ISO 1711-1, the wrenches shall not show any permanent deformation of the jaws which could influence their usability.

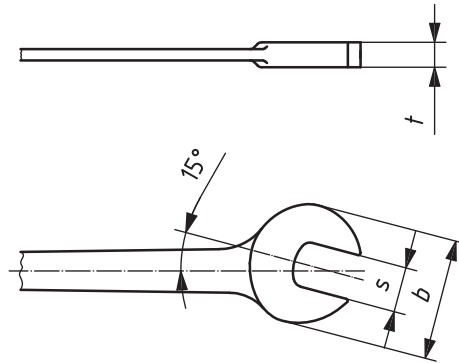

See Table 1.

Figure 1 — Dimensions of heads

5 Designation

A single-head engineer's wrench in accordance with this International Standard shall be designated by:

- a) "wrench";
- b) reference to this International Standard, i.e. ISO 4229:2009;
- c) its opening.

EXAMPLE A single-head engineer's wrench with the wrench opening $s = 18$ mm is designated as follows:

Wrench ISO 4229 - 18

6 Marking

Single-head engineer's wrenches shall be marked, permanently and legibly, with at least the following:

- a) the value of the wrench opening;
- b) the name or trademark of the manufacturer (or the responsible supplier).

Table 1 — Maximum outside dimensions of heads

Dimensions in millimetres

Nominal width across flats s^a	b^b max.	t^c max.
7	20	3,5
8	22	4
10	26	4,5
11	28	5
13	32	5,5
15	36	6
16	39	6,5
18	43	7
21	49	8,5
24	55	9,5
27	62	11
30	68	12
34	76	13,5
36	81	14,5
41	91	16,5
46	102	18,5
50	110	20
55	121	22
60	131	24
65	141	26
70	152	28
75	162	30
80	173	32
85	183	34
90	188	36
95	198	38
100	208	40
105	218	42
110	228	44
115	238	46
120	248	48

^a Width across flats according to ISO 272; tolerances according to ISO 691.

^b For $s \leq 85$, $b_{\max.} = 2,1s + 5$.
For $s > 85$, $b_{\max.} = 2s + 8$.

^c For $s > 13$, $t = 0,4s$.

Table 2 — Test torques

Nominal width across flats s^a mm	Test torque M^b Nm
7	4,6
8	6,6
10	12,4
11	16,1
13	25,8
15	38,5
16	46,1
18	64
21	99
24	143
27	199
30	268
34	381
36	447
41	572
46	719
50	850
55	1 030
60	1 225
65	1 436
70	1 665
75	1 910
80	2 175
85	2 455
90	2 755
95	3 070
100	3 400
105	3 750
110	4 115
115	4 495
120	4 895

^a Width across flats according to ISO 272; tolerances according to ISO 691.

^b For $s \leq 36$, $M = 0,5 \cdot 0,039 2s^{2,8}$.
For $s > 36$, $M = 0,34s^2$.

Bibliography

- [1] ISO 1703, *Assembly tools for screws and nuts — Designation and nomenclature*

