

INTERNATIONAL STANDARD

ISO 4210-6

First edition
2014-07-01

Corrected version
2014-11-01

Cycles — Safety requirements for bicycles —

Part 6: Frame and fork test methods

Cycles — Exigences de sécurité des bicyclettes —

Partie 6: Méthodes d'essai du cadre et de la fourche



Reference number
ISO 4210-6:2014(E)

© ISO 2014



COPYRIGHT PROTECTED DOCUMENT

© ISO 2014

All rights reserved. Unless otherwise specified, no part of this publication may be reproduced or utilized otherwise in any form or by any means, electronic or mechanical, including photocopying, or posting on the internet or an intranet, without prior written permission. Permission can be requested from either ISO at the address below or ISO's member body in the country of the requester.

ISO copyright office
Case postale 56 • CH-1211 Geneva 20
Tel. + 41 22 749 01 11
Fax + 41 22 749 09 47
E-mail copyright@iso.org
Web www.iso.org

Published in Switzerland

Contents

	Page
Foreword	iv
Introduction	v
1 Scope	1
2 Normative references	1
3 Terms and definitions	1
4 Frame test methods	1
4.1 Frame — Impact test (falling mass).....	1
4.2 Frame and front fork assembly — Impact test (falling frame).....	4
4.3 Frame — Fatigue test with pedalling forces.....	6
4.4 Frame — Fatigue test with horizontal forces.....	8
4.5 Frame — Fatigue test with a vertical force.....	9
5 Fork test methods	11
5.1 Suspension forks — Tyre-clearance test.....	11
5.2 Suspension forks — Tensile test.....	12
5.3 Front fork — Static bending test.....	12
5.4 Front fork — Rearward impact test.....	13
5.5 Front fork — Bending fatigue test and rearward impact test.....	16
5.6 Forks intended for use with hub or disc brakes.....	17
5.7 Tensile test for a non-welded fork.....	19
Annex A (normative) Dummy fork characteristics	20
Annex B (normative) Fork mounting fixture	22
Annex C (informative) Suspension frames — Tyre-clearance test	24

Foreword

ISO (the International Organization for Standardization) is a worldwide federation of national standards bodies (ISO member bodies). The work of preparing International Standards is normally carried out through ISO technical committees. Each member body interested in a subject for which a technical committee has been established has the right to be represented on that committee. International organizations, governmental and non-governmental, in liaison with ISO, also take part in the work. ISO collaborates closely with the International Electrotechnical Commission (IEC) on all matters of electrotechnical standardization.

The procedures used to develop this document and those intended for its further maintenance are described in the ISO/IEC Directives, Part 1. In particular the different approval criteria needed for the different types of ISO documents should be noted. This document was drafted in accordance with the editorial rules of the ISO/IEC Directives, Part 2 (see www.iso.org/directives).

Attention is drawn to the possibility that some of the elements of this document may be the subject of patent rights. ISO shall not be held responsible for identifying any or all such patent rights. Details of any patent rights identified during the development of the document will be in the Introduction and/or on the ISO list of patent declarations received (see www.iso.org/patents).

Any trade name used in this document is information given for the convenience of users and does not constitute an endorsement.

For an explanation on the meaning of ISO specific terms and expressions related to conformity assessment, as well as information about ISO's adherence to the WTO principles in the Technical Barriers to Trade (TBT) see the following URL: Foreword - Supplementary information

The committee responsible for this document is ISO/TC 149, *Cycles*, Subcommittee SC 1, *Cycles and major sub-assemblies*.

This first edition of ISO 4210-6, together with ISO 4210-1, ISO 4210-2, ISO 4210-3, ISO 4210-4, ISO 4210-5, ISO 4210-7, ISO 4210-8, and ISO 4210-9, cancels and replaces ISO 4210:1996, which has been technically revised.

ISO 4210 consists of the following parts, under the general title *Cycles — Safety requirements for bicycles*:

- *Part 1: Terms and definitions*
- *Part 2: Requirements for city and trekking, young adult, mountain and racing bicycles*
- *Part 3: Common test methods*
- *Part 4: Braking test methods*
- *Part 5: Steering test methods*
- *Part 6: Frame and fork test methods*
- *Part 7: Wheels and rims test methods*
- *Part 8: Pedals and drive system test methods*
- *Part 9: Saddles and seat-post test methods*

This corrected version of ISO 4210-6:2014 incorporates a correction in Figure 3.

Introduction

This International Standard has been developed in response to demand throughout the world, and the aim has been to ensure that bicycles manufactured in compliance with this International Standard will be as safe as is practically possible. The tests have been designed to ensure the strength and durability of individual parts as well as of the bicycle as a whole, demanding high quality throughout and consideration of safety aspects from the design stage onwards.

The scope has been limited to safety considerations, and has specifically avoided standardization of components.

If the bicycle is to be used on public roads, national regulations apply.

.....

Cycles — Safety requirements for bicycles —

Part 6: Frame and fork test methods

1 Scope

This part of ISO 4210 specifies the frame and fork test methods for ISO 4210-2.

2 Normative references

The following documents, in whole or in part, are normatively referenced in this document and are indispensable for its application. For dated references, only the edition cited applies. For undated references, the latest edition of the referenced document (including any amendments) applies.

ISO 4210-1, *Cycles — Safety requirements for bicycles — Part 1: Terms and definitions*

ISO 4210-2:2014, *Cycles — Safety requirements for bicycles — Part 2: Requirements for city and trekking, young adult, mountain and racing bicycles*

ISO 4210-3:2014, *Cycles — Safety requirements for bicycles — Part 3: Common test methods*

3 Terms and definitions

For the purposes of this document, the terms and definitions given in ISO 4210-1 apply.

4 Frame test methods

4.1 Frame — Impact test (falling mass)

4.1.1 General

Manufacturers of frames are permitted to conduct the test with a dummy fork (see [Annex A](#)) fitted in place of a front fork.

Where a frame is convertible for male and female riders by the removal of a bar, test it with the bar removed.

Where a suspension fork is fitted, test the assembly with the fork extended to its unloaded free length. Where a rear suspension system is incorporated in the frame, secure the suspension in a position equivalent to that which would occur with an 80 kg rider seated on the bicycle. For young adult bicycles, secure the suspension in a position equivalent to that which would occur with a 40 kg rider seated on the bicycle; if the type of suspension system does not permit it to be locked, then replace the spring/damper unit by a solid link of the appropriate size and with end fittings similar to those of the spring/damper unit.

4.1.2 Test method

Assemble a roller of mass less than or equal to 1 kg and with dimensions conforming to those shown in [Figure 1](#) in the fork. The hardness of roller shall be not less than 60 HRC at impact surface. If a dummy fork is used in place of a fork, the bar shall have a rounded end equivalent in shape to the roller. Hold the

frame-fork or frame-bar assembly vertically with clamping to a rigid fixture by the rear-axle attachment points as shown in [Figure 1](#).

Rest a striker of mass 22,5 kg on the roller in the fork dropouts or on the rounded end of the dummy fork and measure the wheelbase. Raise the striker to a height of h_1 above the low-mass roller and release it to strike the roller or the steel bar at a point in line with the wheel centres and against the direction of the fork rake or rake of the bar. The drop heights are given in [Table 1](#). The striker will bounce and this is normal. When the striker has come to rest on the roller or dummy fork, measure the wheelbase again.

If the fork fails, the frame shall be tested with a dummy fork.

NOTE See ISO 4210-3:2014, Annex B.

Table 1 — Drop heights

Dimensions in millimetres

Bicycle type	City and trekking bicycles	Young adult bicycles	Mountain bicycles	Racing bicycles
Drop height, h_1	180	180	360	212

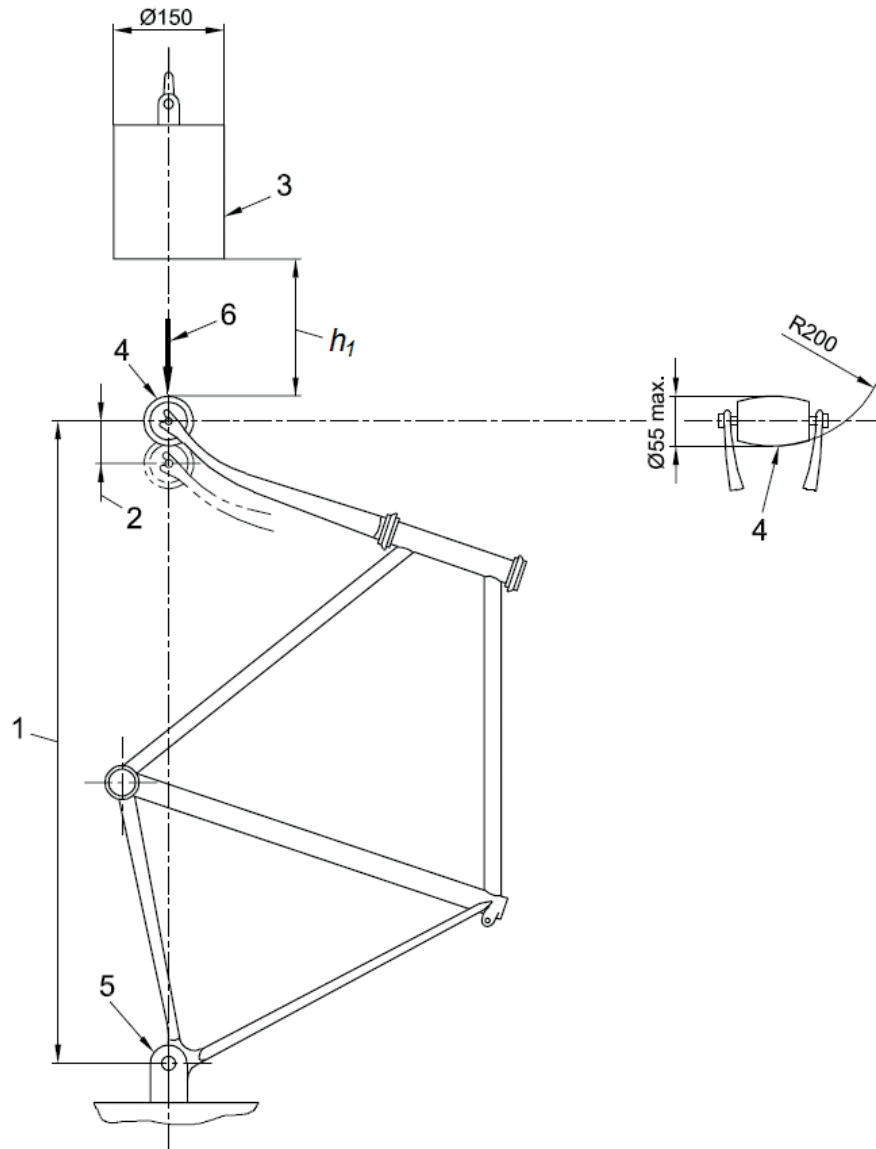

Key

- h_1 drop height
- 1 wheelbase
- 2 permanent deformation
- 3 22,5 kg striker
- 4 low-mass roller (1 kg max.)
- 5 rigid mounting for rear-axle attachment point
- 6 direction of rearward impact

Figure 1 — Frame and front fork assembly — Impact test (falling mass)

4.2 Frame and front fork assembly — Impact test (falling frame)

4.2.1 General

Manufacturers of complete bicycles shall conduct the test with the frame fitted with the appropriate front fork.

For manufacturers of frames, where the fork intended for the frame is not available, the test can be conducted with the frame fitted with a fork which meets the requirements of the fork impact test as described in ISO 4210-2:2014, 4.9.5.

Where a frame is convertible for male and female riders by the removal of a bar, test it with the bar removed.

Where a suspension fork is fitted, it shall be at its unloaded length prior to the impact. If the spring/damper unit can be locked, it shall be locked in its unloaded length position. If the spring/damper cannot be locked, use one of the two following alternative procedures:

- secure the fork at its extended length by an external locking method, or
- replace the fork by a rigid fork which is known to meet the requirements of the impact test described in ISO 4210-2:2014, 4.9.5 and of a length which is consistent with an 80 kg (in case of young adult bicycles, apply 40 kg) rider seated in a normal riding position on the bicycle when it is equipped with the suspension fork.

Where a rear suspension system is incorporated in the frame, secure the spring/damper unit in a position equivalent to that which would occur with an 80 kg (in case of young adult bicycles, apply 40 kg) rider seated on the bicycle; if the type of suspension system does not permit it to be locked, then replace the spring/damper unit by a solid link of the appropriate size and with end fittings similar to those of the spring/damper unit.

4.2.2 Test method

Conduct the test on the assembly used for the test in ISO 4210-2:2014, 4.8.2 or, in the case of a frame manufacturer who does not make forks, with the same frame with a suitable fork fitted (see [4.2.1](#)).

As shown in [Figure 2](#), mount the frame-fork assembly at its rear axle attachment points so that it is free to rotate about the rear axle in a vertical plane. Support the front fork on a flat steel anvil so that the frame is in its normal position of use. Securely fix mass M_1 to the seat-post as shown in [Figure 2](#) with the centre of gravity at distance D ($= 75$ mm) along the seat-post axis from the insertion point, and fix masses of M_2 and M_3 ([Table 2](#)) to the top of the steering head and the bottom bracket, respectively, as shown in [Figure 2](#).

Measure the wheelbase with the three masses in place. Rotate the assembly about the rear axle until the distance between the low-mass roller and the anvil is h_2 , then allow the assembly to fall freely to impact on the anvil.

Repeat the test and then measure the wheelbase again with the three masses in place and the roller resting on the anvil.

Table 2 — Drop heights and distribution of masses at seat post, steering head, and bottom bracket

Bicycle type	City and trekking bicycles	Young adult bicycles	Mountain bicycles	Racing bicycles
Mass 1 Seat-post, M_1 kg	50	40	30	30
Mass 2 Steering head, M_2 kg	10	10	10	10
Mass 3 Bottom bracket, M_3 kg	30	20	50	50
Drop height, h_2 mm	200	200	300	200

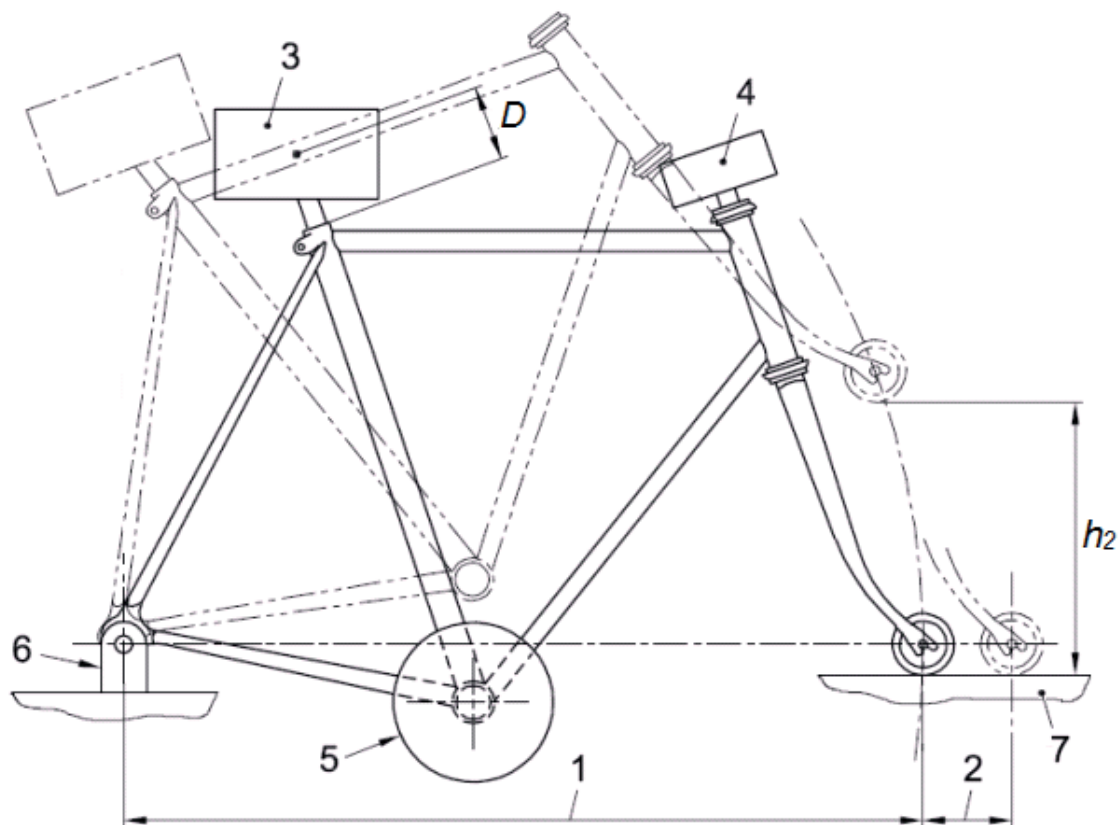
**Key**

- 1 wheelbase
- 2 permanent deformation
- 3 mass 1 (M_1)
- 4 mass 2 (M_2)
- 5 mass 3 (M_3)
- 6 rigid mounting for rear-axle attachment point
- 7 steel anvil
- D distance to the centre of gravity (75 mm)
- h_2 drop height

Figure 2 — Frame and front fork assembly — Impact test (falling frame)

4.3 Frame — Fatigue test with pedalling forces

4.3.1 General

All types of frame shall be subjected to this test.

In tests on suspension frames with pivoted joints, adjust the spring, air pressure, or damper to provide maximum resistance, or, for a pneumatic damper in which the air pressure cannot be adjusted, replace the suspension unit with a rigid link, ensuring that its end fixings and lateral rigidity accurately simulate those of the original unit. For suspension frames in which the chain stays do not have pivots but rely on flexing, ensure that any dampers are set to provide the minimum resistance in order to ensure adequate testing of the frame.

Where a suspension frame has adjustable brackets or linkages to vary the resistance of the bicycle against the ground-contact forces or to vary the attitude of the bicycle, arrange the positions of these adjustable components to ensure maximum forces in the frame.

4.3.2 Test method

Use a new frame/fork assembly fitted with standard head tube bearings for the test. The front fork can be replaced by a dummy fork (see [Annex A](#)) of the same length and at least the same stiffness as the original fork.

NOTE If a genuine fork is used, failures of the fork are possible; therefore, it is recommended that for convenience, a dummy fork stiffer and stronger than the genuine fork be used.

Where a frame is convertible for male and female riders by the removal of a bar, test it with the bar removed.

Mount the frame assembly on a base as shown in [Figure 3](#) with the fork or dummy fork secured by its axle to a rigid mount of height R_w (the radius of the wheel/tyre assembly ± 30 mm) and with the hub free to swivel on the axle. Secure the rear dropouts by means of the axle to a stiff, vertical link of the same height as that of the front, rigid mount, the upper connection of the link being free to swivel about the axis of the axle but providing rigidity in a lateral plane, and the lower end of the link being fitted with a ball-joint.

Fit a crank, chain wheel and chain assembly or, preferably, a strong, stiff, replacement assembly to the bottom bracket as shown in [Figure 3](#) and described in item a) or b) below.

- a) If a crank/chain-wheel assembly is used, incline both cranks forwards and downwards at an angle of 45° (accurate to within $\pm 2,0^\circ$) to the horizontal and secure the front end of the chain to the middle chain wheel of three, the smaller chain wheel of two, or the only chain wheel. Attach the rear end of the chain to the rear axle and perpendicular to the axis of the axle.
- b) If an adaptor assembly is used (as shown in [Figure 3](#)), ensure that the assembly is free to swivel about the axis of the bottom-bracket and that both replacement arms are 175 mm long (L) and that they are both inclined forwards and downwards at an angle of 45° (accurate to within $\pm 2,0^\circ$) to the horizontal. Secure the position of the crank replacement arms by a vertical arm (which replaces the chain wheel) and a tie rod which has ball joints at both ends and which is attached to the rear axle perpendicular to the axis of the rear axle. The length of the vertical arm (R_c) shall be 75 mm and the axis of the tie rod shall be parallel to and 50 mm from the vertical plane through the centreline of the frame.

Subject each pedal spindle (or equivalent adaptor component) to a repeated downward force of F_1 at a position 150 mm from the centreline of the frame in a vertical, transverse plane and inclined at $7,5^\circ$ (accurate to within $\pm 0,5^\circ$) to the fore/aft plane of the frame as shown in [Table 3](#) and [Figure 3](#). During application of these test forces, ensure that the force on a "pedal spindle" falls to 5 % or less of the peak force before commencing application of the test force to the other "pedal spindle".

Apply the test forces for 100 000 test cycles, where one test cycle consists of the application and removal of the two test forces. The maximum test frequency shall be maintained as specified in ISO 4210-3:2014, 4.5.

Table 3 — Forces on pedal spindle

Forces in newtons

Bicycle type	City and trekking bicycles	Young adult bicycles	Mountain bicycles	Racing bicycles
Force, F_1	1 000	1 000	1 200	1 100

Dimensions in millimetres

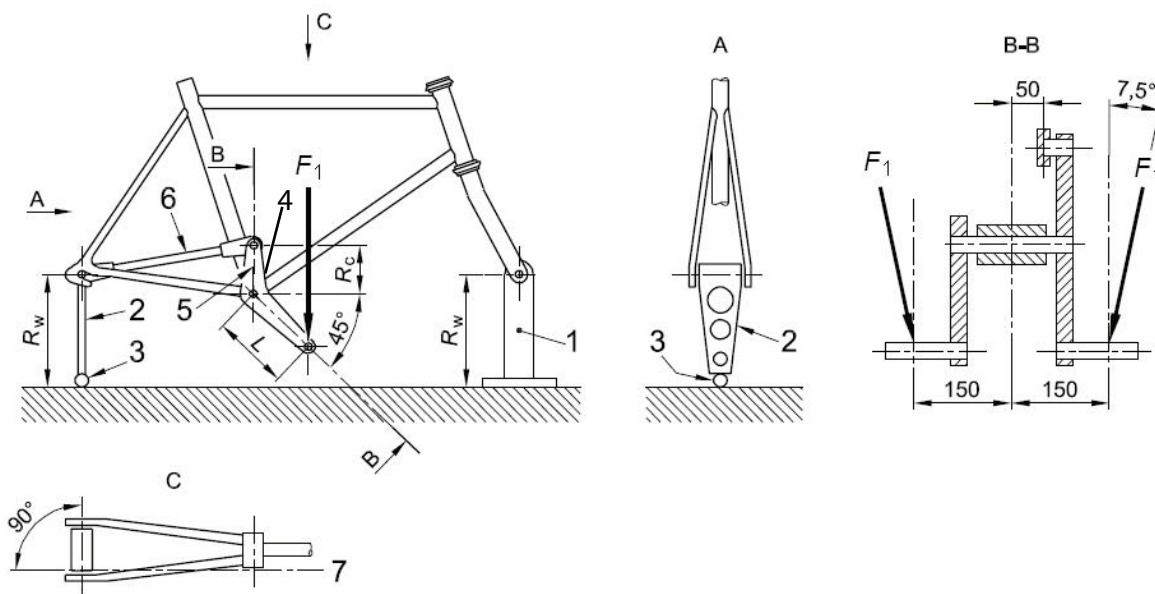

Key

- R_w height of rigid mount and vertical link
- R_c length of vertical arm (75 mm)
- L length of crank replacement (175 mm)
- 1 rigid mount
- 2 vertical link
- 3 ball joint
- 4 adaptor assembly
- 5 vertical arm
- 6 tie rod
- 7 centreline of tie rod

Figure 3 — Frame — Fatigue test with pedalling forces

4.4 Frame — Fatigue test with horizontal forces

4.4.1 General

Where a frame is convertible for male and female riders by the removal of a bar, remove the bar.

It is not necessary for a genuine fork to be fitted, provided that any substitute fork is of the same length as the intended fork (see [Annex A](#)) and it is correctly installed in the steering-head bearings. For a suspension fork, lock it at a length equivalent to that with an 80 kg (in case of young adult bicycles, apply 40 kg) rider seated on the bicycle either by adjusting the spring/damper or by external means.

In tests on suspension frames with pivoted joints, lock the moving part of the frame into a position as would occur with an 80 kg rider seated on the bicycle. This can be achieved by locking the suspension unit in an appropriate position or, if the type of suspension system does not permit it to be locked, then the suspension system can be replaced by a solid link of the appropriate compressed size. Ensure that the axes of the front and rear axles are horizontally in line, as shown in [Figure 4](#). For suspension frames in which the chain stays do not have pivots but rely on flexing, ensure that any dampers are set to provide the minimum resistance in order to ensure adequate testing of the frame.

Where a suspension frame has adjustable brackets or linkages to vary the resistance of the bicycle against the ground-contact forces or to vary the attitude of the bicycle, arrange the positions of these adjustable components to ensure maximum forces in the frame.

4.4.2 Test method

Mount the frame in its normal attitude and secured at the rear dropouts so that it is not restrained in a rotary sense (i.e. preferably by the rear axle) as shown in [Figure 4](#). Ensure that the axis of the front and rear axles are horizontally in line.

Apply cycles of dynamic, horizontal forces of F_2 in a forward direction and F_3 in a rearward direction to the front fork dropouts for C_1 cycles as shown in [Table 4](#) and [Figure 4](#), with the front fork constrained in vertical direction but free to move in a fore/aft direction under the applied forces. The maximum test frequency shall be maintained as specified in ISO 4210-3:2014, 4.5.

Table 4 — Forces and cycles on front fork dropouts

Bicycle type	City and trekking bicycles	Young adult bicycles	Mountain bicycles	Racing bicycles
Forward force, F_2 N	450	450	1 200	600
Rearward force, F_3 N	450	450	600	600
Test cycles, C_1	100 000	100 000	50 000	100 000

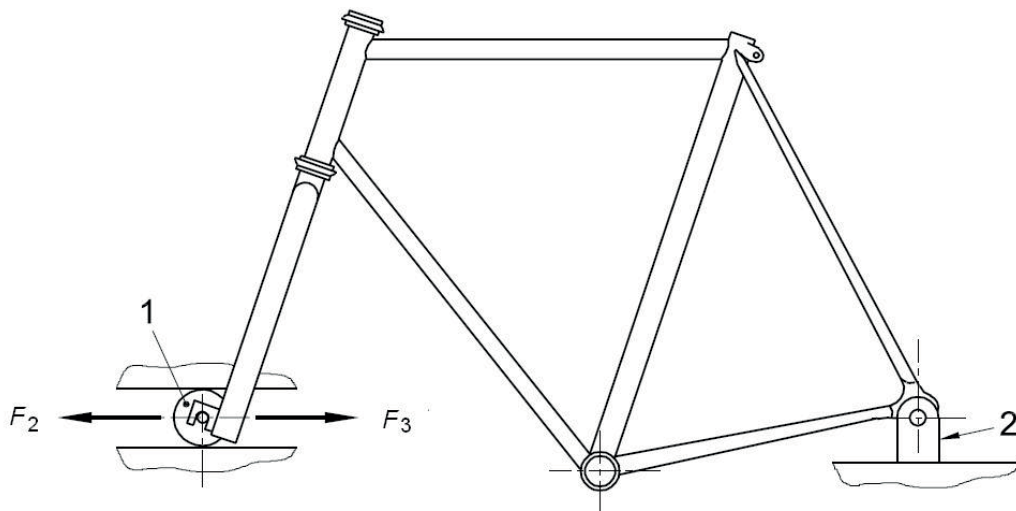

Key

- 1 free-running guided roller
- 2 rigid, pivoted mounting for rear-axle attachment point

Figure 4 — Frame — Fatigue test with horizontal forces

4.5 Frame — Fatigue test with a vertical force

4.5.1 General

Where a frame is convertible for male and female riders by the removal of a bar, remove the bar.

Where a suspension frame has adjustable brackets or linkages to vary the resistance of the bicycle against the ground-contact forces or to vary the attitude of the bicycle, arrange the positions of these adjustable components to ensure maximum forces in the frame. Secure the rear suspension as described in 4.3.1.

If a suspension fork is fitted lock it at a length equivalent to that with an 80 kg (in case of young adult bicycles, apply 40 kg) rider seated on the bicycle either by adjusting the spring/damper or by external means.

4.5.2 Test method

Mount the frame in its normal attitude and secured at the rear dropouts so that is not restrained in a rotary sense (i.e. preferably by the rear axle) as shown in Figure 5. Fit a suitable roller to the front axle in order to permit the frame to flex in a fore/aft sense under the test forces.

Insert intended seat post at minimum insertion depth or equivalent to a seat stem to a depth of 75 mm in the top of the seat tube and secure this to the manufacturer’s instructions by the normal clamp. Securely attach a horizontal, rearward extension (E in Figure 5) to the top of this bar such that its length (dimension h_3 in Figure 5) places point H in a position equivalent to that of the centre of the saddle clamp with the bicycle at its maximum saddle height recommended for the particular frame, or, if the maximum saddle height information is not available, dimension h_3 shall be 250 mm.

Apply cycles of dynamic, vertically-downward forces of F_4 at a point 70 mm behind the intersection of the axes of the solid steel bar and the extension piece, E, as shown in Figure 5 for 50 000 test cycles. The forces are given in Table 5. The maximum test frequency shall be maintained as specified in ISO 4210-3:2014, 4.5.

Table 5 — Forces on seat stem

Forces in newtons

Bicycle type	City and trekking bicycles	Young adult bicycles	Mountain bicycles	Racing bicycles
Force, F_4	1 000	500	1 200	1 200

Dimensions in millimetres

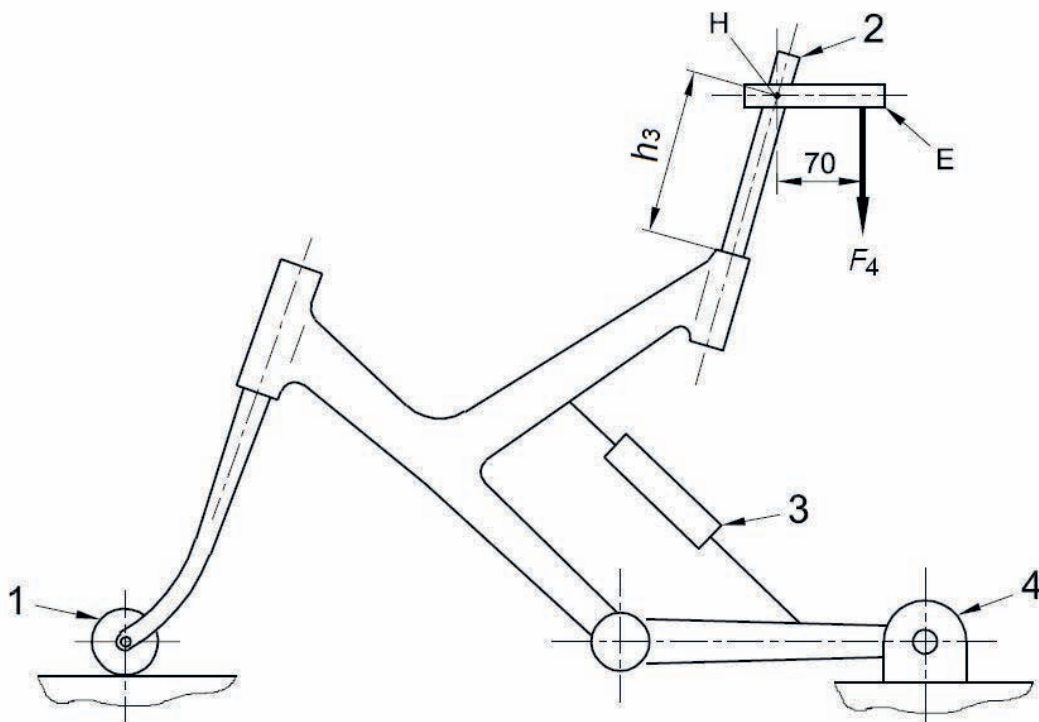
**Key**

- E horizontal, rearward extension
- H position equivalent to that of the centre of the saddle clamp with the bicycle
- 1 free-running roller
- 2 steel bar
- 3 locked suspension unit or solid link for pivoted chain stays
- 4 rigid, pivoted mounting for rear axle attachment point

Figure 5 — Frame — Fatigue test with a vertical force**5 Fork test methods****5.1 Suspension forks — Tyre-clearance test**

For the tyre-clearance test, a suspension fork shall first be checked and adjusted if necessary according to the items listed in the following:

- a) inflate the tyre to the maximum inflation pressure;
- b) place the fork in uncompressed condition to have the highest displacement between suspension stanchion legs and suspension lower legs;
- c) if the suspension fork can be locked, place the fork in the open position;
- d) if the fork has a spring adjust device, place it in the softest position;
- e) if the fork has a pneumatic device, inflate the one or the two chambers at their minimum pressures according the manufacturer's instruction;
- f) if the fork has a rebound device, place it on the slowest position.

With a wheel and tyre assembly fitted to the fork, apply a force of 2 800 N to the wheel in a direction towards the fork-crown and parallel to the axis of the fork steerer. Maintain this force for 1 min.

5.2 Suspension forks — Tensile test

Mount the fork steerer securely in a suitable rigid mount, keeping any clamping forces away from the fork-crown, and apply a tensile force of 2 300 N distributed equally between the two dropouts in a direction parallel to the axis of the fork steerer and in the direction away from the fork crown. Maintain this force for 1 min.

5.3 Front fork — Static bending test

Mount the fork according to Annex B and fit a loading attachment and swivel on an axle located in the axle slots of the blades (see Figure 6). Locate a deflection measuring device over the loading attachment in order to measure deflection and permanent deformation of the fork perpendicular to the steerer axis and in the plane of the wheel.

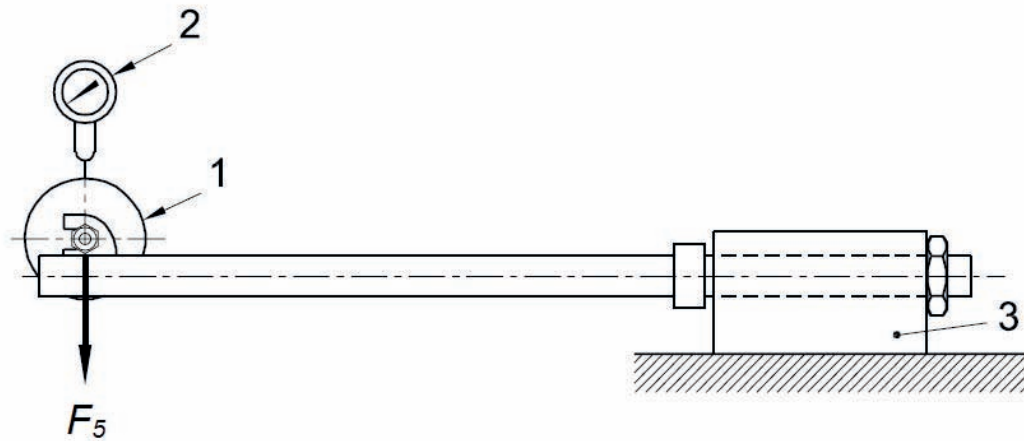

- Key**
- 1 loading attachment swivel on axle
 - 2 deflection measuring device
 - 3 rigid mount incorporating head bearings

Figure 6 — Front fork — Static bending test (typical arrangement)

Apply a static, pre-loading force of 100 N to the roller perpendicular to the steerer axis, against the direction of travel, and in the plane of the wheel. Remove and repeat this loading until a consistent deflection reading is obtained. Adjust the deflection measuring device to zero.

Increase the static force to F_5 and maintain this force for 1 min, then reduce the force to 100 N and record any permanent deformation. The forces are given in Table 6.

Table 6 — Forces on loading attachment

Forces in newtons

Bicycle type	City and trekking bicycles	Young adult bicycles	Mountain bicycles	Racing bicycles
Force, F_5	1 000	1 000	1 500	1 200

5.4 Front fork — Rearward impact test

5.4.1 Test method 1

Mount the fork according to [Annex B](#) as shown in [Figure 7](#). Assemble a roller of mass less than or equal to 1 kg and with dimensions conforming to those shown in [Figure 8](#) in the fork. The hardness of the roller shall be not less than 60 HRC at impact surface.

Rest a striker of mass $22,5 \text{ kg} \pm 0,1 \text{ kg}$ on the roller in the fork dropouts such that it is exerting a force against the direction of travel and in the plane of the wheel. Position a deflection measuring device under the roller and record the position of the roller in a direction perpendicular to the axis of the fork steerer and in the plane of the wheel and note the vertical position of the fork.

Remove the deflection measuring device, raise the striker through a height of h_4 , and release it to strike the roller against the rake of the fork. The drop heights are given in [Table 7](#). The striker will bounce and this is normal. When the striker has come to rest on the roller, measure the permanent deformation under the roller.

NOTE See ISO 4210-3:2014, Annex B.

Table 7 — Drop heights

Dimensions in millimetres

Bicycle type		City and trek- king bicycles	Young adult bicycles	Mountain bicy- cles	Racing bicycles
Drop height, h_4	Forks made entirely of metal	180	180	360	360
	Forks which have composite parts	320	320	600	640

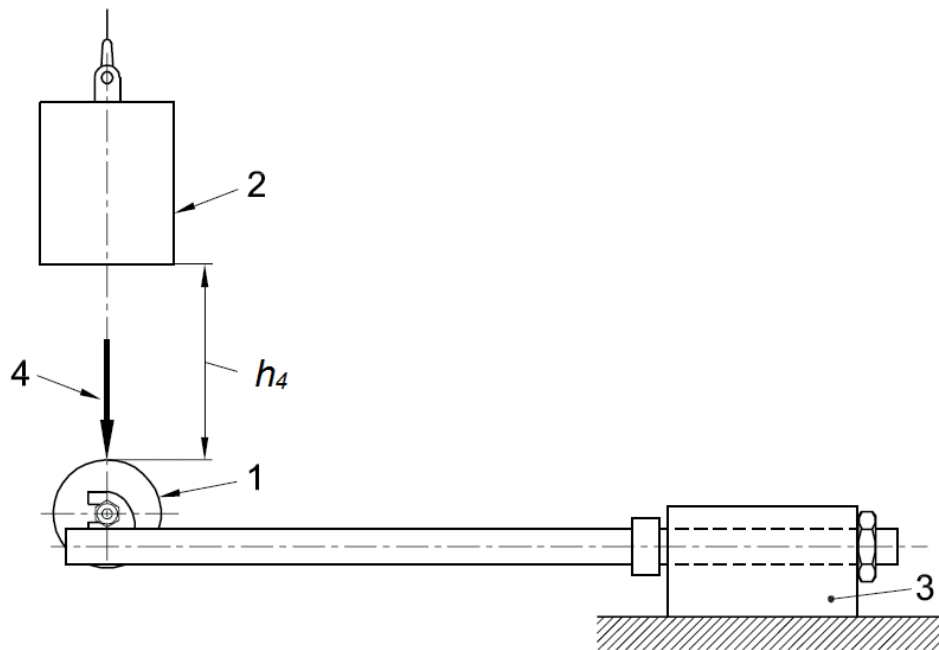

Key

- h_4 drop height
- 1 low-mass roller (1 kg max.)
- 2 22,5 kg striker
- 3 rigid mount incorporating head bearings
- 4 direction of rearward impact

Figure 7 — Front fork — Rearward impact test

Dimensions in millimetres

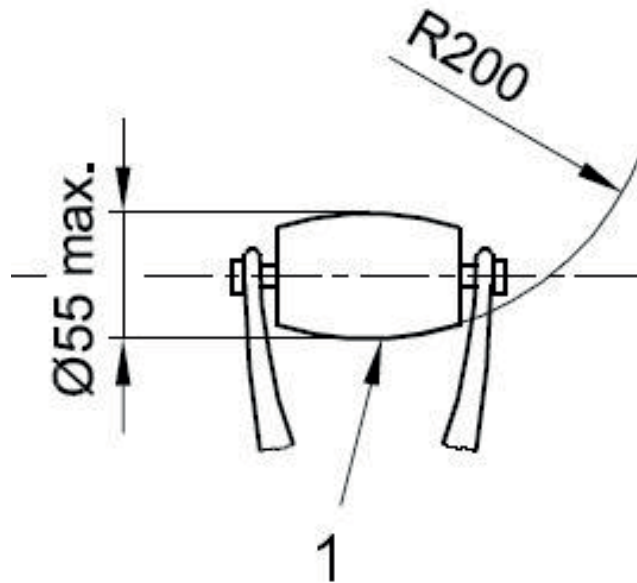

Key

1 low-mass roller (1 kg max.)

Figure 8 — Low-mass roller

5.4.2 Test method 2

This test is similar to that described in 5.4.1 except the dropping height.

As shown in Figure 7, mount the fork used for the test in 5.4.1 and assemble a low-mass roller in the fork. Raise the striker to a height of 600 mm above the roller and release it to strike the roller against the rake of the fork. The section applies to forks in ISO 4210-2:2014, 4.9.5.1.

5.4.3 Test method 3

Apply a torque of T to the assembly and maintain for 1 min in each direction of possible rotation about the steerer axis. The torque is given in Table 8, and a typical example of test equipment is illustrated in Figure 9.

Table 8 — Torque on fork

Torques in newton metres

Bicycle type	City and trekking bicycles	Young adult bicycles	Mountain bicycles	Racing bicycles
Torque, T	50	50	80	80

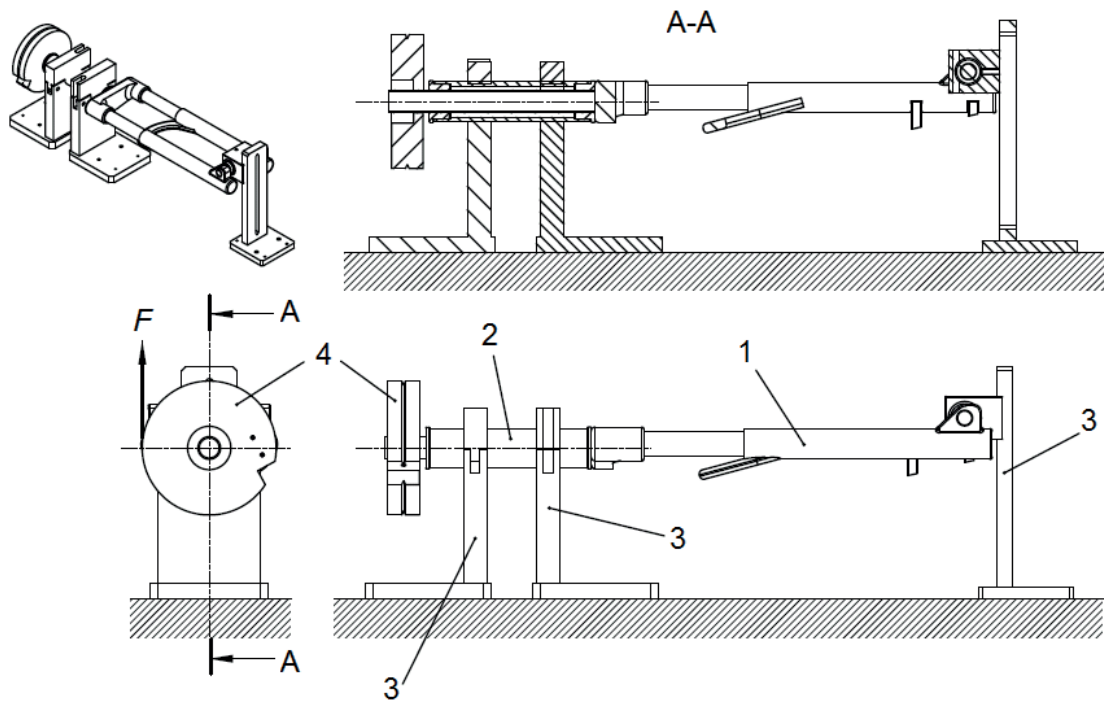

Key

- 1 front fork
- 2 fork mounting fixture (fixture representative of the head tube)
- 3 rigid mount
- 4 test adaptor

Figure 9 — Fork steerer torsional test (a typical example)

5.5 Front fork — Bending fatigue test and rearward impact test

Mount the fork according to [Annex B](#) as shown in [Figure 10](#).

Apply cycles of fully reversed, dynamic forces of F_6 in the plane of the wheel and perpendicular to the fork steerer tube to a loading attachment and swivel on an axle located in the axle-slots of the blades for 100 000 test cycles. The forces are given in [Table 9](#). The maximum test frequency shall be maintained as specified in ISO 4210-3:2014, 4.5.

Conclude the test if the running displacement (peak-to-peak value) at the point where the test forces are applied increases by more than 20 % for rigid forks or more than 40 % for suspension forks from the initial values (see ISO 4210-3:2014, 4.6).

Stop the test after 100 000 cycles and inspect the sample carefully for fractures. If fractures are found, conclude the test.

If the sample completes 100 000 cycles without exceeding the displacement limits noted above, and if no fractures can be observed, perform the impact resistance test described in [5.4.1](#) (the drop heights are given in [Table 7](#)). When the striker has come to rest on the roller, measure the permanent deformation under the roller and inspect the sample carefully for fractures.

Table 9 — Forces on loading attachment

Forces in newtons				
Bicycle type	City and trekking bicycles	Young adult bicycles	Mountain bicycles	Racing bicycles
Force, F_6	±450	±450	±650	±620

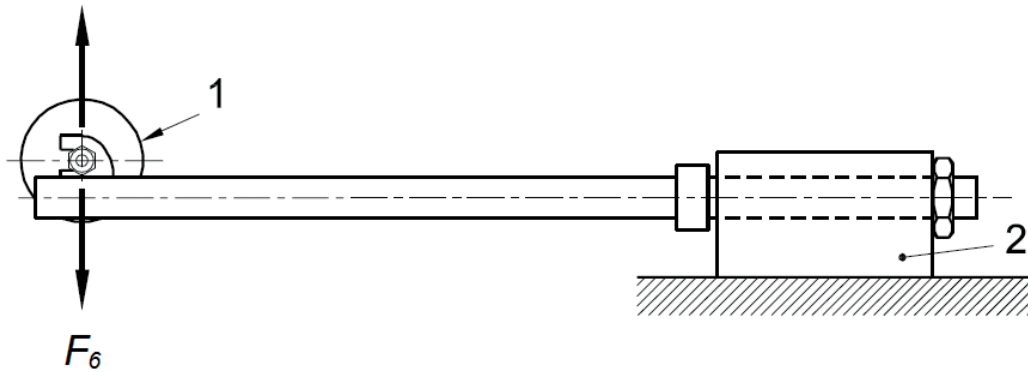
**Key**

- 1 pivoted force attachment
- 2 rigid mount incorporating head bearings

Figure 10 — Front fork — Bending fatigue test

5.6 Forks intended for use with hub or disc brakes**5.6.1 General**

When a fork is intended for use with a hub or disc brake and whether supplied as original equipment or as an accessory, the fork manufacturer shall provide an attachment point on the fork blade for the torque arm or calliper.

In tests conducted by the methods described in 5.6.2 and 5.6.3 and where more than one mounting point is provided for a hub or disc brake, the following shall apply:

- a) where a complete bicycle is supplied, the test adaptor shall be secured to the mounting point used on the bicycle. If bracket will be supplied, it shall be used to perform the test;
- b) where a fork is supplied as an accessory with more than one mounting point, separate tests shall be conducted on each of the mounting points on separate forks.

5.6.2 Fork for hub/disc brake — Static brake-torque test

Mount the fork in a fixture representative of the head tube according to Annex B and gripped in the normal head-bearings, fit an axle to the fork, and mount on the axle a pivoted, straight adaptor as shown in Figure 11 to provide a torque arm of L_2 in length (see Table 10) and a suitable attachment for the brake mounting point. If the wheel size is not listed in Table 10, the length L_2 shall be equal to one-half of the wheel diameter.

Locate a deflection-measuring device on the fork at the hub axis in order to measure deflection and permanent deformation of the fork perpendicular to the fork steerer axis and in the plane of the wheel.

Apply a static, pre-loading rearward force of 100 N to the end of the torque arm, perpendicular to the fork steerer axis and in the plane of the wheel. Remove and repeat this loading until a consistent deflection

reading is obtained. Adjust the deflection measuring device to zero. Apply a rearward force of 1 000 N to the torque arm perpendicular to the fork steerer axis and in the plane of the wheel. Maintain this force for 1 min, then reduce the force to 100 N and record any permanent deformation.

Table 10 — Fixture length

Dimensions in millimetres

Wheel diameter	24"	26"	650b	29" or 700c
Arm length, L_2	305	330	349	368

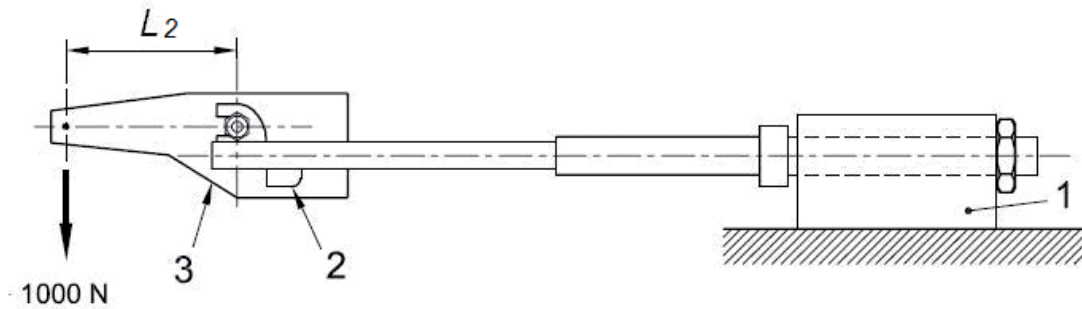

Key

- 1 rigid mount incorporating head bearings
- 2 brake mounting point
- 3 test adaptor

Figure 11 — Fork for hub/disc brake — Static brake-torque test

5.6.3 Fork for hub/disc brake — Brake mount fatigue test

Mount the fork in a fixture representative of the head tube according to Annex B and gripped in the normal head-bearings, fit an axle to the fork, and mount on the axle a pivoted, straight adaptor as shown in Figure 12 to provide a torque arm of L_2 in length (see Table 10) and a suitable attachment for the brake mounting point.

Apply repeated, dynamic forces of 600 N rearward to the end of the torque arm, perpendicular to the fork steerer axis and in the plane of the wheel (as shown in Figure 12) for C_2 cycles (see Table 11). The maximum test frequency shall be maintained as specified in ISO 4210-3:2014, 4.5.

Table 11 — Minimum test cycles

Bicycle type	City and trekking bicycles	Young adult bicycles	Mountain bicycles	Racing bicycles
Test cycles, C_2	12 000	12 000	12 000	20 000

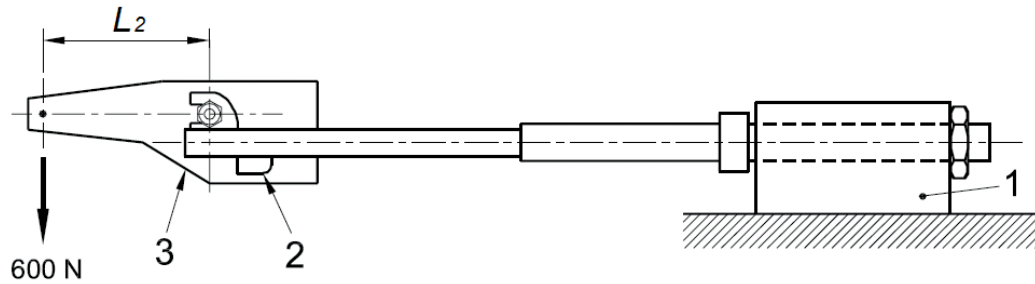
**Key**

- 1 rigid mount incorporating head bearings
- 2 brake mounting point
- 3 test adaptor

Figure 12 — Fork for hub/disc-brake — Brake mount fatigue test

5.7 Tensile test for a non-welded fork

Mount the fork steerer securely in a suitable rigid mount, keeping any clamping forces away from the fork-crown, and apply a tensile force of 5 000 N distributed equally to both dropouts for 1 min in a direction parallel to the axis of the fork steerer.

Annex A (normative)

Dummy fork characteristics

The test forks shall be designed to mount in a manner similar to the original fork, or in a manner using typical procedures (see [Annex B](#)).

The test forks, when mounted, shall be the same length (axle to race), L , as the longest fork designed for use with the frame.

The deflection of the test fork shall be measured in the direction of the force application at the front axle centre, from the resulting application of a vertical force of 1 200 N. The fork shall be secured in a horizontal position by constraining the steerer tube by means of a false head tube (with bearings) equal to 150 mm in length. The steerer tube shall be secured as in a bicycle with the crown race seat adjacent to the false head tube lower bearing assembly (see [Figure B.1](#) in [Annex B](#)).

- a) The deflection ratio, D_r , for the test fork for the horizontal loading fatigue test and the vertical loading fatigue test shall not exceed the value of 1,0 when computed as follows:

$$D_r = \frac{K_1 \times 10\,000 \times \delta}{L^3} \quad (\text{A.1})$$

where

D_r is the deflection ratio;

K_1 is 1 417, a constant;

L is the fork length, expressed in millimetres;

δ is the deflection, expressed in millimetres.

EXAMPLE

Fork length $L = 460$ mm

Deflection $\delta = 6,85$ mm, from which

Deflection ratio D_r

$$= \frac{1\,417 \times 10\,000 \times 6,85}{460^3}$$

$$= 0,99721 \leq 1,0$$

- b) The deflection ratio, D_r , for the test fork for the impact test shall not exceed the value of 1,0 when computed as follows:

$$D_r = \frac{K_2 \times 10000 \times \delta}{L^3} \quad (\text{A.2})$$

where

D_r is the deflection ratio;

K_2 is 709, a constant;

L is the fork length, expressed in millimetres;

δ is the deflection, expressed in millimetres.

.....

Annex B (normative)

Fork mounting fixture

The fork shall be mounted in a fixture representative of the head tube and gripped in the normal head-bearings. The distance between the bearings can have an influence on the results. Therefore, when known the real mounting distance shall be used with a tolerance of ± 5 mm. If no indication about the distance is given, a value of (150 ± 5) mm shall be taken. The measurement points are taken from the middle of the bearings. Examples of distance measurements are given in [Figure B.1](#).

During loading, the fork steerer will bend and can touch the dummy head tube. The design of the dummy tube shall be such that this contact shall not occur.

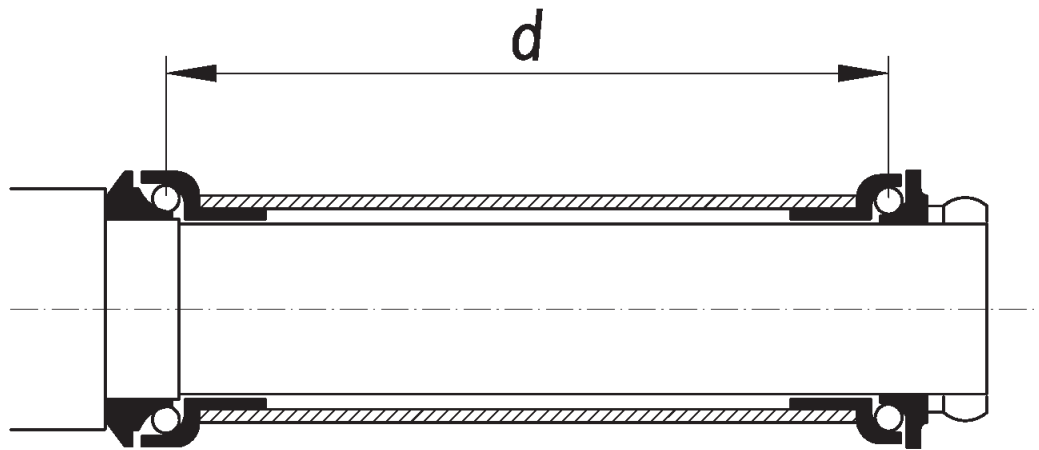

a) Measurement with external cup bearings

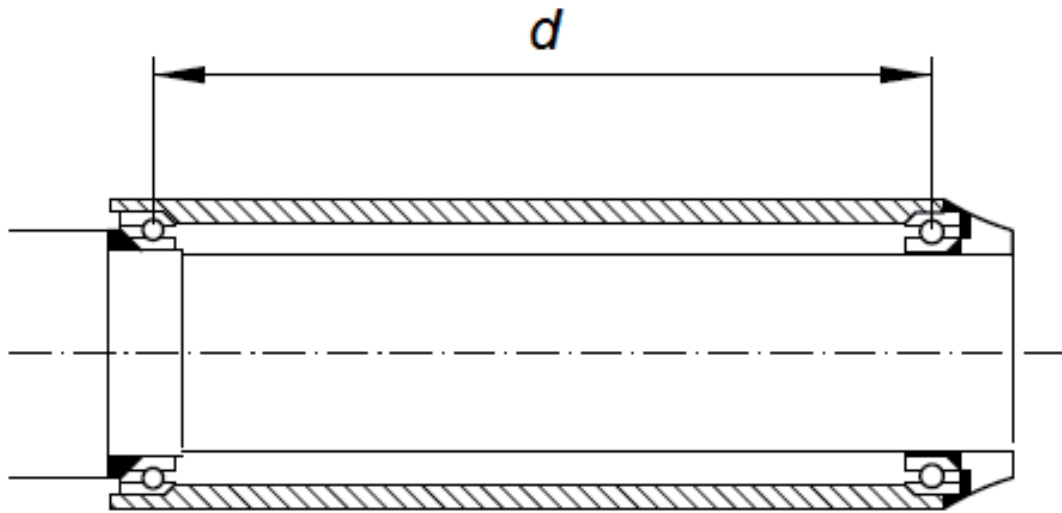

b) Measurement with integrated bearings

Key

d distance between the bearings

Figure B.1 — Examples of distance measurements

Annex C (informative)

Suspension frames — Tyre-clearance test

C.1 Suspension frames — Tyre-clearance test

C.1.1 Requirements

When tested by the method described in [C.1.2](#), the tyre or any components other than fixing mechanism shall not contact the frame nor shall the components separate.

C.1.2 Test method

For the tyre-clearance test, a suspension frame and wheel shall first be checked and adjusted according to the items listed in the following:

- a) inflate the tyre to the maximum inflation pressure;
- b) if the frame's suspension element can be locked, place it in the open position;
- c) if the frame's suspension element is a pneumatic shock, pressurize the chamber to the minimum pressure according to the manufacturer's instruction.

Secure the frame in an orientation that allows a force to be applied to the wheel from a simulated ground plane. With a wheel and tyre assembly fitted to the frame, apply a force of 2 800 N to the wheel in a direction perpendicular to the simulated ground plane such that the suspension is compressed (see [Figure C.1](#)). Maintain the force for 1 min.

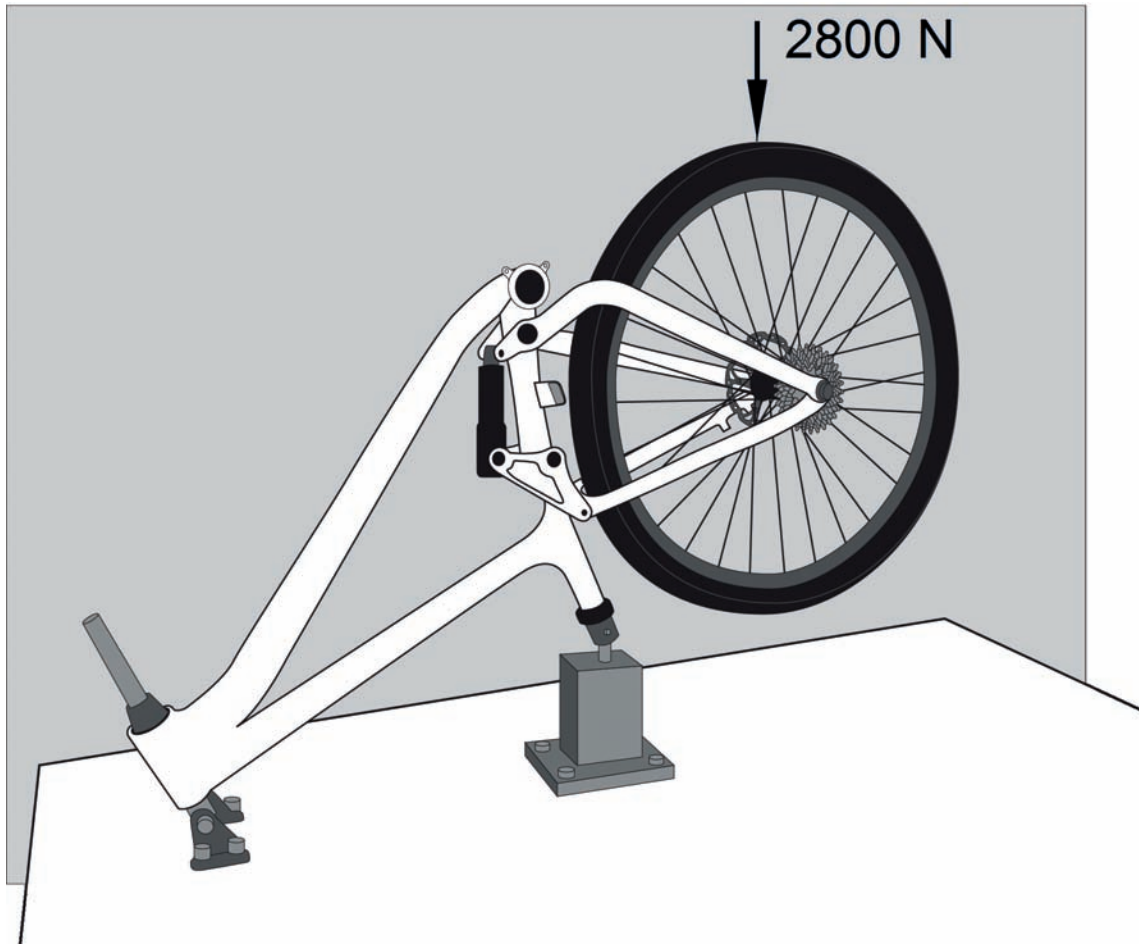

Figure C.1 — Examples of suspension frames — Tyre-clearance test

