**Cycles — Safety requirements for
bicycles —**

**Part 3:
Common test methods**

*Cycles — Exigences de sécurité des bicyclettes —
Partie 3: Méthodes d'essai communes*



Reference number
ISO 4210-3:2014(E)

© ISO 2014



COPYRIGHT PROTECTED DOCUMENT

© ISO 2014

All rights reserved. Unless otherwise specified, no part of this publication may be reproduced or utilized otherwise in any form or by any means, electronic or mechanical, including photocopying, or posting on the internet or an intranet, without prior written permission. Permission can be requested from either ISO at the address below or ISO's member body in the country of the requester.

ISO copyright office
Case postale 56 • CH-1211 Geneva 20
Tel. + 41 22 749 01 11
Fax + 41 22 749 09 47
E-mail copyright@iso.org
Web www.iso.org

Published in Switzerland

Contents

	Page
Foreword	iv
Introduction	v
1 Scope	1
2 Normative references	1
3 Terms and definitions	1
4 Test methods	1
4.1 Brake tests and strength tests	1
4.2 Front mudguard test methods	2
4.3 Road test on a fully assembled bicycle test methods	4
4.4 Durability test of marking	4
4.5 Fatigue test	5
4.6 Fatigue test for composite components	5
4.7 Impact test	5
4.8 Plastic material test ambient temperature	5
Annex A (informative) Structural integrity of the fully assembled bicycle	6
Annex B (informative) Verification of free-fall velocity	8
Bibliography	9

Foreword

ISO (the International Organization for Standardization) is a worldwide federation of national standards bodies (ISO member bodies). The work of preparing International Standards is normally carried out through ISO technical committees. Each member body interested in a subject for which a technical committee has been established has the right to be represented on that committee. International organizations, governmental and non-governmental, in liaison with ISO, also take part in the work. ISO collaborates closely with the International Electrotechnical Commission (IEC) on all matters of electrotechnical standardization.

The procedures used to develop this document and those intended for its further maintenance are described in the ISO/IEC Directives, Part 1. In particular the different approval criteria needed for the different types of ISO documents should be noted. This document was drafted in accordance with the editorial rules of the ISO/IEC Directives, Part 2 (see www.iso.org/directives).

Attention is drawn to the possibility that some of the elements of this document may be the subject of patent rights. ISO shall not be held responsible for identifying any or all such patent rights. Details of any patent rights identified during the development of the document will be in the Introduction and/or on the ISO list of patent declarations received (see www.iso.org/patents).

Any trade name used in this document is information given for the convenience of users and does not constitute an endorsement.

For an explanation on the meaning of ISO specific terms and expressions related to conformity assessment, as well as information about ISO's adherence to the WTO principles in the Technical Barriers to Trade (TBT) see the following URL: Foreword - Supplementary information

The committee responsible for this document is ISO/TC 149, *Cycles*, Subcommittee SC 1, *Cycles and major sub-assemblies*.

This first edition of ISO 4210-3, together with ISO 4210-1, ISO 4210-2, ISO 4210-4, ISO 4210-5, ISO 4210-6, ISO 4210-7, ISO 4210-8, and ISO 4210-9, cancels and replaces ISO 4210:1996, which has been technically revised.

ISO 4210 consists of the following parts, under the general title *Cycles — Safety requirements for bicycles*:

- *Part 1: Terms and definitions*
- *Part 2: Requirements for city and trekking, young adult, mountain and racing bicycles*
- *Part 3: Common test methods*
- *Part 4: Braking test methods*
- *Part 5: Steering test methods*
- *Part 6: Frame and fork test methods*
- *Part 7: Wheels and rims test methods*
- *Part 8: Pedals and drive system test methods*
- *Part 9: Saddles and seat-post test methods*

Introduction

This International Standard was developed in response to a demand throughout the world. The aim is to ensure that bicycles manufactured in compliance with this International Standard will be as safe as is practically possible. The tests are designed to ensure the strength and durability of individual parts as well as of the bicycle as a whole, demanding high quality throughout and consideration of safety aspects from the design stage onwards.

The scope is limited to safety considerations, and has specifically avoided standardization of components.

If the bicycle is to be used on public roads, national regulations apply.

.....

Cycles — Safety requirements for bicycles —

Part 3: Common test methods

1 Scope

This part of ISO 4210 specifies the common test methods for ISO 4210-2.

2 Normative references

The following referenced documents, in whole or in part, are normatively referenced in this document and are indispensable for its application. For dated references, only the edition cited applies. For undated references, the latest edition of the referenced document (including any amendments) applies.

ISO 4210-1, *Cycles — Safety requirements for bicycles — Part 1: Terms and definitions*

ISO 4210-2:2014, *Cycles — Safety requirements for bicycles — Part 2: Requirements for city and trekking, young adult, mountain and racing bicycles*

ISO 4210-4:2014, *Cycles — Safety requirements for bicycles — Part 4: Braking test methods*

3 Terms and definitions

For the purposes of this document, the terms and definitions given in ISO 4210-1 apply.

4 Test methods

4.1 Brake tests and strength tests

4.1.1 Definition of brake tests

Brake tests to which accuracy requirements apply, as in [4.1.4](#), are those specified in ISO 4210-2:2014, 4.6.3 to 4.6.6, ISO 4210-4:2014, 4.2, and ISO 4210-4:2014, 4.6.3.3.

4.1.2 Definition of strength tests

Strength tests to which accuracy requirements apply, as in [4.1.4](#), are those involving static, impact, or fatigue loading as specified in ISO 4210-2:2014, 4.7 to 4.13, ISO 4210-2:2014, 4.16, and ISO 4210-2:2014, 4.20.2.

4.1.3 Numbers and condition of specimens for the strength tests

In general, for static, impact, and fatigue tests, each test shall be conducted on a new test sample, but if only one sample is available, it is permissible to conduct all of these tests on the same sample with the sequence of testing being fatigue, static, and impact.

When more than one test is conducted on the same sample, the test sequence shall be clearly recorded in the test report or record of testing. It should be noted that if more than one test is conducted on the same sample, earlier tests can influence the results of subsequent tests. Also, if a sample fails when it has been subjected to more than one test, a direct comparison with single testing is not possible.

In all strength tests, specimens shall be in the fully finished condition.

4.1.4 Accuracy tolerances of test conditions for brake tests and strength tests

Unless stated otherwise, accuracy tolerances based on the nominal values shall be as follows.

Forces and torques	0/+5 %
Masses and weights	±1 %
Dimensions	±1 mm
Angles	±1°
Time duration	±5 s
Temperatures	±2 °C
Pressures	±5 %

4.2 Front mudguard test methods

4.2.1 Front mudguard with stays test methods

4.2.1.1 Stage 1: Test method — Tangential obstruction

Insert a 12-mm-diameter steel rod between the spokes, in contact with the rim and below the front mudguard stays as shown in [Figure 1](#), and rotate the wheel to apply a tangentially upward force of 160 N, against the front mudguard stays; maintain this force for 1 min.

Remove the rod and determine whether or not the wheel is free to rotate and whether or not any damage to the front mudguard adversely affects wheel rotation (blocking of the wheel) and the steering.

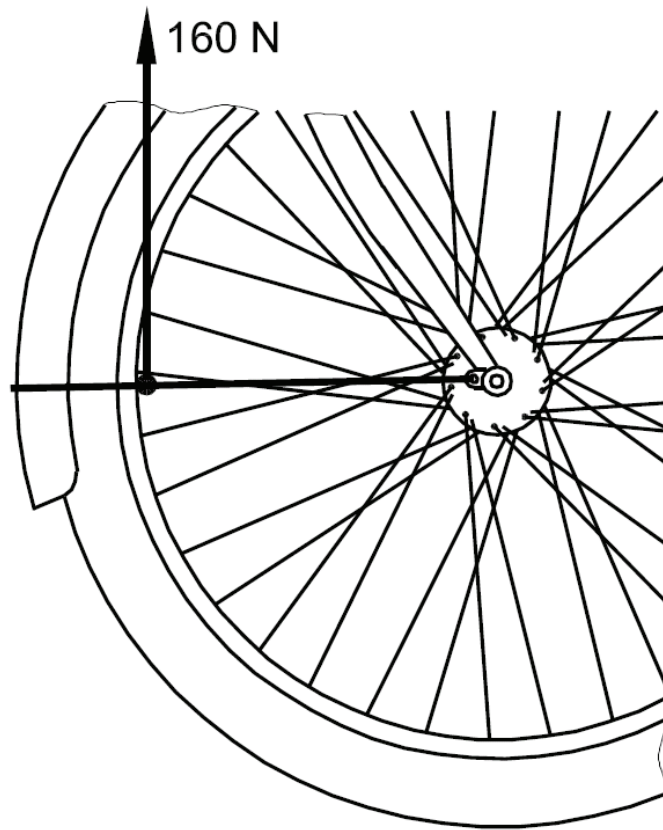

Figure 1 — Front mudguard — Tangential obstruction test

4.2.1.2 Stage 2: Test method — Radial force

Press the front mudguard at a distance of 20 mm from its free end (not taking the flap into consideration) with a 20-mm-diameter, flat-ended tool radially towards the tyre with a force of 80 N as shown in [Figure 2](#).

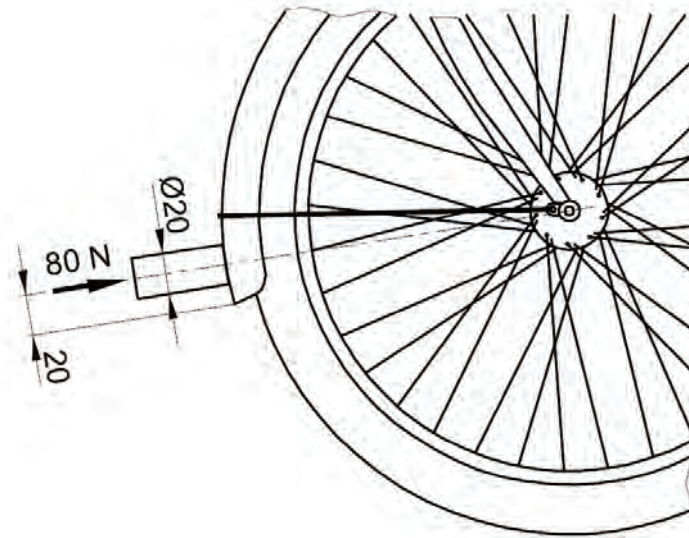

Figure 2 — Front mudguard — Radial force test

While the force is maintained, rotate the wheel manually in the direction of forward movement of the bicycle and determine whether or not the wheel is free to rotate, and whether or not any damage to the front mudguard adversely affects wheel rotation (blocking of the wheel) and the steering.

4.2.2 Front mudguard without stays test methods

Press the front mudguard at a distance of 20 mm from its free end with a 20-mm-diameter, flat-ended tool radially towards the tyre with a force of 80 N as shown in [Figure 2](#).

While the force is maintained, rotate the wheel manually in the direction of forward movement of the bicycle and determine whether or not the front mudguard is rolled up the wheel, and whether or not any damage to the front mudguard adversely affects wheel rotation (blocking of the wheel) or obstructs the steering. Contact between tyre and mudguard is allowed.

4.3 Road test on a fully assembled bicycle test methods

First, check and adjust, if necessary, each bicycle selected for the road test to ensure that the steering and wheels rotate freely without slackness and that brakes are correctly adjusted and do not impede wheel rotation. Check and adjust wheel alignment and, if necessary, inflate tyres to the maximum inflation pressure. Check and correct, if necessary, transmission-chain adjustment, and check any gear controls for correct and free operation.

Carefully adjust the saddle and handlebar positions to suit the rider.

The test shall be carried out with the permissible total weight specified by the manufacturer in ISO 4210-2:2014, Clause 5 item h). Ensure that the bicycle is ridden for at least 1 km.

4.4 Durability test of marking

Rub the marking by hand for 15 s with a piece of cloth soaked in water and again for 15 s with a piece of cloth soaked in petroleum spirit.

4.5 Fatigue test

The force for fatigue tests is to be applied and released progressively, not to exceed 10 Hz. The tightness of fasteners according to manufacturer's recommended torque can be re-checked not later than 1 000 test cycles to allow for the initial settling of the component assembly. (This is considered applicable to all components, where fasteners are present for clamping.) The test bench shall be qualified to meet the dynamic requirements of [4.1.4](#).

NOTE Examples of suitable methods are listed in Reference [\[1\]](#).

4.6 Fatigue test for composite components

For fatigue test for composite components, the initial value of displacement (peak-to-peak value) is taken after 1 000 cycles and before 2 000 cycles.

4.7 Impact test

For all vertical impact tests, the striker shall be guided in such a way that the efficiency will permit to reach at least 95 % of the free-fall velocity.

NOTE See [Annex B](#).

4.8 Plastic material test ambient temperature

All strength tests involving any plastic materials shall be pre-conditioned for 2 h and tested at an ambient temperature of $23\text{ °C} \pm 5\text{ °C}$.

.....

Annex A (informative)

Structural integrity of the fully assembled bicycle

A.1 Requirement

When tested by the method described in [A.2](#), there should be no system or component failure and no loosening or misalignment of the saddle, handlebar, controls, lighting equipment, or reflectors.

A.2 Machine test

Mount a fully assembled bicycle on a test machine. The following weights should be applied:

- one 36 kg weight with a pin for insertion in the seat-post and divided into two halves to be hung, one on each side;
- two 18 kg weights with fixtures for attaching them to the cranks in place of the pedals;
- two 6,75 kg weights with fixtures for attaching them to each side of the handlebar;
- one 10 kg, 18 kg, or 25 kg weight with the dimensions 240 mm × 240 mm on the luggage carrier.

An example of a test arrangement is shown in [Figure A.1](#), in which the bicycle is mounted on two drums. The diameter of the drums should be in a range from 500 mm to 1 000 mm, and the slots should have a width of 50 mm ± 2,5 mm, a thickness of 10 mm ± 0,25 mm, and 45° chamfered edges of half their thickness. The circumferential spacing between the centrelines of two consecutive slots should be not less than 400 mm.

Rotate the drums to give a linear surface speed of 8 km/h (±10 %) for a period of 6 h.

The tyres of the bicycle should be inflated to the maximum inflation pressure.

Dimensions in millimetres

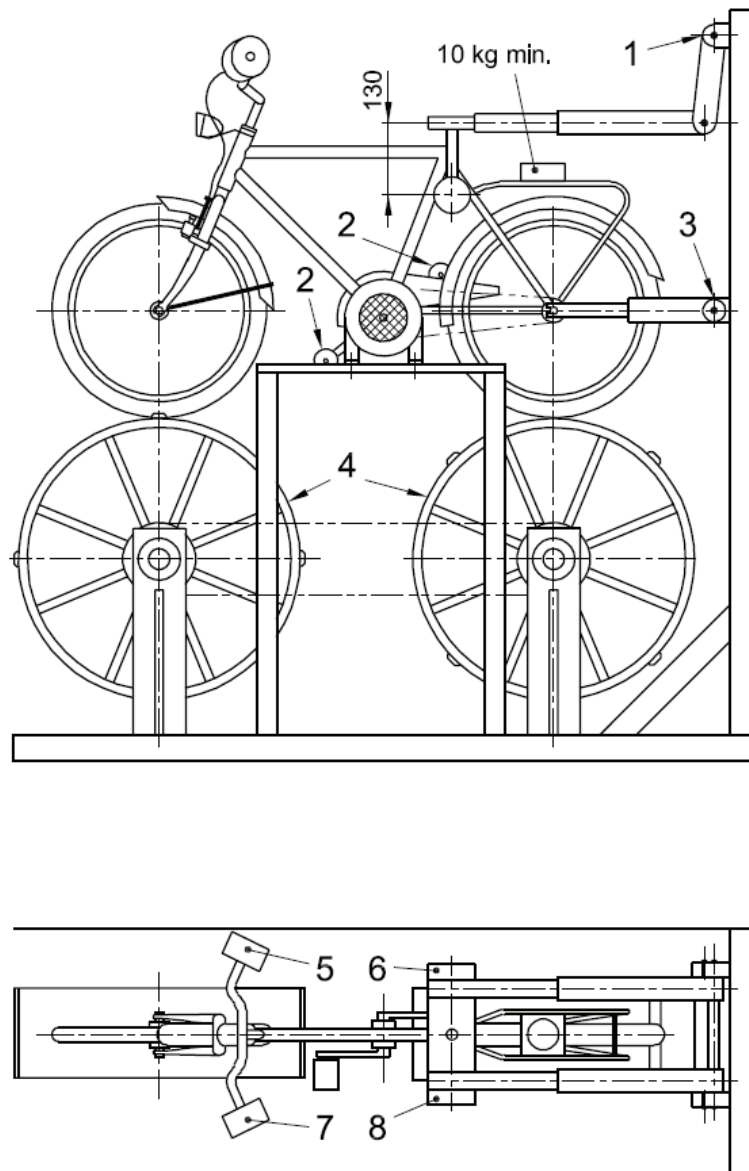

Key

- 1 adjustable height
- 2 weight, 18 kg
- 3 height adjustable
- 4 drum diameter, 760 mm
- 5 weight, 6,75 kg
- 6 weight, 18 kg
- 7 weight, 6,75 kg
- 8 weight, 18 kg

Figure A.1 — Dynamic strength test on a fully assembled bicycle

Annex B (informative)

Verification of free-fall velocity

For all vertical impact tests, the striker shall be guided in such a way that the efficiency will permit to reach at least 95 % of the free-fall velocity.

The free-fall velocity is calculated using Formula (B.1):

$$v = \sqrt{2gh} \quad (\text{B.1})$$

where

v is the free-fall velocity (m/s);

g is the gravitational acceleration (m/s²) (i.e. = 9,806 65 m/s²);

h is the falling height (m).

The efficiency is equal to Formula (B.2)

$$\mu = \frac{v_i}{v} \times 100 \quad (\text{B.2})$$

where

μ is the efficiency (%);

v_i is the measured speed at impact (m/s).

Bibliography

- [1] ASTM E467, *Standard Practice for Verification of Constant Amplitude Dynamic Forces in an Axial Fatigue Testing System*

1
2
3
4
5
6
7
8
9
10
11
12
13
14
15
16
17
18
19
20
21
22
23
24
25
26
27
28
29
30
31
32
33
34
35
36
37
38
39
40
41
42
43
44
45
46
47
48
49
50
51
52
53
54
55
56
57
58
59
60
61
62
63
64
65
66
67
68
69
70
71
72
73
74
75
76
77
78
79
80
81
82
83
84
85
86
87
88
89
90
91
92
93
94
95
96
97
98
99
100

ICS 43.150

Price based on 9 pages