**Cycles — Safety requirements for
bicycles —**

**Part 2:
Requirements for city and trekking,
young adult, mountain and racing
bicycles**

Cycles — Exigences de sécurité des bicyclettes —

Partie 2: Exigences pour bicyclettes de ville et de randonnée, de jeune adulte, de montagne et de course





COPYRIGHT PROTECTED DOCUMENT

© ISO 2015, Published in Switzerland

All rights reserved. Unless otherwise specified, no part of this publication may be reproduced or utilized otherwise in any form or by any means, electronic or mechanical, including photocopying, or posting on the internet or an intranet, without prior written permission. Permission can be requested from either ISO at the address below or ISO's member body in the country of the requester.

ISO copyright office
Ch. de Blandonnet 8 • CP 401
CH-1214 Vernier, Geneva, Switzerland
Tel. +41 22 749 01 11
Fax +41 22 749 09 47
copyright@iso.org
www.iso.org

Contents

	Page
Foreword	v
Introduction	vi
1 Scope	1
2 Normative references	2
3 Terms and definitions	2
4 Requirements	2
4.1 Toxicity.....	2
4.2 Sharp edges.....	2
4.3 Security and strength of safety-related fasteners.....	2
4.3.1 Security of screws.....	2
4.3.2 Minimum failure torque.....	3
4.3.3 Folding bicycle mechanism.....	3
4.4 Crack detection methods.....	3
4.5 Protrusions.....	3
4.6 Brakes.....	3
4.6.1 Braking systems.....	3
4.6.2 Hand-operated brakes.....	4
4.6.3 Attachment of brake assembly and cable requirements.....	5
4.6.4 Brake-block and brake-pad assemblies — Security test.....	5
4.6.5 Brake adjustment.....	6
4.6.6 Hand-operated braking-system — Strength test.....	6
4.6.7 Back-pedal braking system — Strength test.....	6
4.6.8 Braking performance.....	6
4.6.9 Brakes — Heat-resistance test.....	9
4.7 Steering.....	9
4.7.1 Handlebar — Dimensions.....	9
4.7.2 Handlebar grips and plugs.....	10
4.7.3 Handlebar stem — Insertion-depth mark or positive stop.....	10
4.7.4 Handlebar stem to fork steerer — Clamping requirements.....	10
4.7.5 Steering stability.....	11
4.7.6 Steering assembly — Static strength and security tests.....	11
4.7.7 Handlebar and stem assembly — Fatigue test.....	13
4.8 Frames.....	13
4.8.1 Suspension-frames — Special requirements.....	13
4.8.2 Frame — Impact test (falling mass).....	13
4.8.3 Frame and front fork assembly — Impact test (falling frame).....	14
4.8.4 Frame — Fatigue test with pedalling forces.....	14
4.8.5 Frame — Fatigue test with horizontal forces.....	14
4.8.6 Frame — Fatigue test with a vertical force.....	14
4.9 Front fork.....	14
4.9.1 General.....	14
4.9.2 Means of location of the axle and wheel retention.....	14
4.9.3 Suspension forks — Special requirements.....	15
4.9.4 Front fork — Static bending test.....	15
4.9.5 Front fork — Rearward impact test.....	15
4.9.6 Front fork — Bending fatigue test plus rearward impact test.....	15
4.9.7 Forks intended for use with hub- or disc-brakes.....	16
4.9.8 Tensile test for a non-welded fork.....	16
4.10 Wheels and wheel/tyre assembly.....	16
4.10.1 Wheels/tyre assembly — Concentricity tolerance and lateral tolerance.....	16
4.10.2 Wheel/tyre assembly — Clearance.....	16
4.10.3 Wheel/tyre assembly — Static strength test.....	17
4.10.4 Wheels — Wheel retention.....	17

4.10.5	Wheels — Quick-release devices — Operating features	18
4.11	Rims, tyres, and tubes	18
4.11.1	General	18
4.11.2	Tyre inflation pressure	18
4.11.3	Tyre and rim compatibility	18
4.11.4	Tubular tyres and rims	18
4.11.5	Rim-wear	19
4.11.6	Greenhouse effect test for composite wheels	19
4.12	Front mudguard	19
4.13	Pedals and pedal/crank drive system	19
4.13.1	Pedal tread	19
4.13.2	Pedal clearance	20
4.13.3	Pedal — Static strength test	21
4.13.4	Pedal — Impact test	21
4.13.5	Pedal — Dynamic durability test	21
4.13.6	Drive system — Static strength test	21
4.13.7	Crank assembly — Fatigue test	22
4.14	Drive-chain and drive belt	22
4.14.1	Drive-chain	22
4.14.2	Drive belt	22
4.15	Chain-wheel and belt-drive protective device	22
4.15.1	Requirements	22
4.15.2	Chain-wheel disc and drive pulley disc diameter	23
4.15.3	Chain and drive belt protective device	24
4.15.4	Combined front gear-change guide	25
4.16	Saddles and seat-posts	26
4.16.1	Limiting dimensions	26
4.16.2	Seat-post — Insertion-depth mark or positive stop	26
4.16.3	Saddle/seat-post — Security test	26
4.16.4	Saddle — Static strength test	27
4.16.5	Saddle and seat-post clamp — Fatigue test	27
4.16.6	Seat-post — Fatigue test	27
4.17	Spoke protector	27
4.18	Luggage carriers	28
4.19	Road test of a fully assembled bicycle	28
4.20	Lighting systems and reflectors	28
4.20.1	General	28
4.20.2	Wiring harness	28
4.20.3	Lighting systems	28
4.20.4	Reflectors	28
4.21	Warning device	29
5	Manufacturer's instructions	29
6	Marking	31
6.1	Requirement	31
6.2	Durability test	31
Annex A (informative) Steering geometry		32
Bibliography		33

Foreword

ISO (the International Organization for Standardization) is a worldwide federation of national standards bodies (ISO member bodies). The work of preparing International Standards is normally carried out through ISO technical committees. Each member body interested in a subject for which a technical committee has been established has the right to be represented on that committee. International organizations, governmental and non-governmental, in liaison with ISO, also take part in the work. ISO collaborates closely with the International Electrotechnical Commission (IEC) on all matters of electrotechnical standardization.

The procedures used to develop this document and those intended for its further maintenance are described in the ISO/IEC Directives, Part 1. In particular the different approval criteria needed for the different types of ISO documents should be noted. This document was drafted in accordance with the editorial rules of the ISO/IEC Directives, Part 2 (see www.iso.org/directives).

Attention is drawn to the possibility that some of the elements of this document may be the subject of patent rights. ISO shall not be held responsible for identifying any or all such patent rights. Details of any patent rights identified during the development of the document will be in the Introduction and/or on the ISO list of patent declarations received (see www.iso.org/patents).

Any trade name used in this document is information given for the convenience of users and does not constitute an endorsement.

For an explanation on the meaning of ISO specific terms and expressions related to conformity assessment, as well as information about ISO's adherence to the WTO principles in the Technical Barriers to Trade (TBT) see the following URL: [Foreword - Supplementary information](#)

The committee responsible for this document is ISO/TC 149, *Cycles*, Subcommittee SC 1, *Cycles and major sub-assemblies*.

This second edition cancels and replaces the first edition (ISO 4210-2:2014), which has been technically revised.

ISO 4210 consists of the following parts, under the general title *Cycles — Safety requirements for bicycles*:

- *Part 1: Terms and definitions*
- *Part 2: Requirements for city and trekking, young adult, mountain and racing bicycles*
- *Part 3: Common test methods*
- *Part 4: Braking test methods*
- *Part 5: Steering test methods*
- *Part 6: Frame and fork test methods*
- *Part 7: Wheels and rim test methods*
- *Part 8: Pedal and drive system test methods*
- *Part 9: Saddles and seat-post test methods*

Introduction

This International Standard has been developed in response to demand throughout the world, and the aim has been to ensure that bicycles manufactured in compliance with this International Standard will be as safe as is practically possible. The tests have been designed to ensure the strength and durability of individual parts as well as of the bicycle as a whole, demanding high quality throughout and consideration of safety aspects from the design stage onwards.

The scope has been limited to safety considerations and has specifically avoided standardization of components.

If the bicycle is to be used on public roads, national regulations apply.

For the purposes of improving repeatability and reproducibility and considering the applicability to all types of bicycle and the size and influence of the operator, the machine test method reflects today's state of the art and is preferred to the track test method.

Unless there is evidence of improvement of the test track method in the future, this method will be made informative for the next revision. Users of this International Standard are invited to provide their feedback to ISO/TC 149/SC 1.

Cycles — Safety requirements for bicycles —

Part 2:

Requirements for city and trekking, young adult, mountain and racing bicycles

1 Scope

This part of ISO 4210 specifies safety and performance requirements for the design, assembly, and testing of bicycles and sub-assemblies having saddle height as given in [Table 1](#), and lays down guidelines for manufacturer's instructions on the use and care of such bicycles.

This part of ISO 4210 applies to young adult bicycles with maximum saddle height of 635 mm or more and less than 750 mm, city and trekking bicycles, mountain bicycles, and racing bicycles that have a maximum saddle height of 635 mm or more including folding bicycles (see [Table 1](#) and [Figure 1](#)).

This part of ISO 4210 does not apply to specialized types of bicycle, such as delivery bicycles, recumbent bicycles, tandems, BMX bicycles, and bicycles designed and equipped for use in severe applications such as sanctioned competition events, stunting, or aerobic manoeuvres.

NOTE For bicycles with a maximum saddle height of 435 mm or less, see ISO 8124-1, and with a maximum saddle height of more than 435 mm and less than 635 mm, see ISO 8098.

Table 1 — Maximum saddle height

Dimensions in millimetres

Bicycle type	City and trekking bicycles	Young adult bicycles	Mountain bicycles	Racing bicycles
Maximum saddle height	635 or more	635 or more and less than 750	635 or more	635 or more

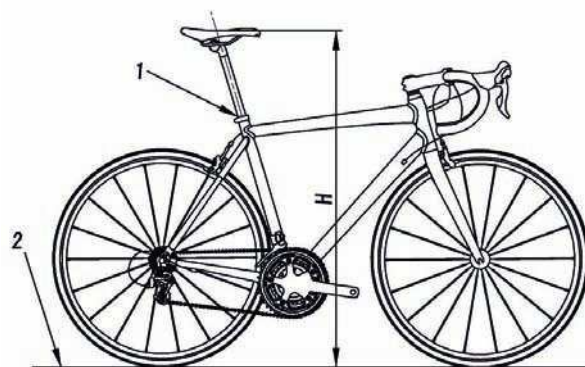

Key

- H* maximum saddle height
- 1 minimum insertion-depth mark
- 2 ground plane

Figure 1 — Maximum saddle height

2 Normative references

The following documents, in whole or in part, are normatively referenced in this document and are indispensable for its application. For dated references, only the edition cited applies. For undated references, the latest edition of the referenced document (including any amendments) applies.

ISO 4210-1, *Cycles — Safety requirements for bicycles — Part 1: Terms and definitions*

ISO 4210-3:2014, *Cycles — Safety requirements for bicycles — Part 3: Common test methods*

ISO 4210-4:2014, *Cycles — Safety requirements for bicycles — Part 4: Braking test methods*

ISO 4210-5:2014, *Cycles — Safety requirements for bicycles — Part 5: Steering test methods*

ISO 4210-6:2015, *Cycles — Safety requirements for bicycles — Part 6: Frame and fork test methods*

ISO 4210-7:2014, *Cycles — Safety requirements for bicycles — Part 7: Wheels and rims test methods*

ISO 4210-8:2014, *Cycles — Safety requirements for bicycles — Part 8: Pedal and drive system test methods*

ISO 4210-9:2014, *Cycles — Safety requirements for bicycles — Part 9: Saddles and seat-post test methods*

ISO 5775-1, *Bicycle tyres and rims — Part 1: Tyre designations and dimensions*

ISO 5775-2, *Bicycle tyres and rims — Part 2: Rims*

ISO 6742-1, *Cycles — Lighting and retro-reflective devices — Part 1: Lighting and light signalling devices*

ISO 6742-2, *Cycles — Lighting and retro-reflective devices — Part 2: Retro-reflective devices*

ISO 9633, *Cycle chains — Characteristics and test methods*

ISO 11243, *Cycles — Luggage carriers for bicycles — Concepts, classification and testing*

3 Terms and definitions

For the purposes of this document, the terms and definitions given in ISO 4210-1 apply.

4 Requirements

4.1 Toxicity

Any items which come into intimate contact with the rider (i.e. causing any hazard due to sucking or licking) shall comply with any national regulations specific to children's products.

4.2 Sharp edges

Exposed edges that could come into contact with the rider's hands, legs, etc., during normal riding or normal handling and normal maintenance shall not be sharp, e.g. deburred, broken, rolled, or processed with comparable techniques.

NOTE Refer to ISO 13715:2000.

4.3 Security and strength of safety-related fasteners

4.3.1 Security of screws

Any screws used in the assembly of suspension systems, brackets attached to electric generators, brake mechanisms and mudguards to the frame or fork, and the saddle to the seat-post shall be provided with

suitable locking devices, e.g. lock-washers, lock-nuts, thread locking compound, or stiff nuts. Fasteners used to assemble hub and disc brakes should have heat-resistant locking devices.

NOTE 1 The screws used to attach the hub generator are not included.

NOTE 2 For example, mechanical and physical properties of bolts are specified in ISO 898-1.

4.3.2 Minimum failure torque

The minimum failure torque of bolted joints for the fastening of handle bars, handlebar stems, bar ends, saddle and seat-posts shall be at least 50 % greater than the manufacturer's recommended tightening torque.

4.3.3 Folding bicycle mechanism

If folding bicycle mechanism is provided, it shall be designed so that the bicycle can be locked for use in a simple, stable, safe way, and when folded, no damage shall occur to any cables. No locking mechanism shall contact the wheels or tyres during riding, and it shall be impossible to unintentionally loosen or unlock the folding mechanisms during riding.

4.4 Crack detection methods

Standardized methods should be used to emphasize the presence of cracks where visible cracks are specified as criteria of failure in tests specified in this part of ISO 4210.

NOTE For example, suitable dye-penetrant methods are specified in ISO 3452-1, ISO 3452-2, ISO 3452-3, and ISO 3452-4. In addition, white paint or surface treatment can be used to aid in detection for composite materials.

4.5 Protrusions

This requirement is intended to address the hazards associated with the users of bicycles falling on projections or rigid components (e.g. handlebars, levers) on a bicycle, possibly causing internal injury or skin puncture.

Tubes and rigid components in the form of projections which constitute a puncture hazard to the rider should be protected. The size and shape of the end protection has not been stipulated, but an adequate shape shall be given to avoid puncturing of the body. Screw threads which constitute a puncture hazard shall be limited to a protrusion length of one major diameter of the screw beyond the internally threaded mating part.

NOTE Handlebar ends are covered in [4.7.2](#).

4.6 Brakes

4.6.1 Braking systems

A bicycle shall be equipped with at least two independently actuated braking systems. At least one shall operate on the front wheel and one on the rear wheel. The braking systems shall operate without binding and shall be capable of meeting the braking performance requirements of [4.6.8](#).

Brake blocks containing asbestos shall not be permitted.

4.6.2 Hand-operated brakes

4.6.2.1 Brake lever position

The brake levers for front and rear brakes shall be positioned according to the legislation or custom and practice of the country in which the bicycle is to be sold, and the bicycle manufacturer shall state in the manufacturer's instructions which levers operate the front and rear brakes [see also [Clause 5](#), item b)].

4.6.2.2 Brake lever grip dimensions

a) The brake lever similar to type A or type B

The dimension, d , measured between the outer surfaces of the brake lever in the region intended for contact with the rider's fingers and the handlebar or any other covering present shall cover a distance of not less than 40 mm as shown in [Figure 2 a\)](#) and [Figure 2 b\)](#) and conform to the following:

- on bicycles on which the minimum intended height of the saddle is 635 mm or more, d shall not exceed 90 mm;
- on bicycles on which the minimum intended height of the saddle is less than 635 mm, d shall not exceed 75 mm.

Conformance shall be established by the method detailed in ISO 4210-4:2014, 4.1.1. The range of adjustment on the brake lever should permit these dimensions to be obtained.

NOTE See [Clause 5](#), item c) in relation to the minimum intended height of the saddle.

b) The brake lever similar to type C

It shall be possible to fit the dimension gauge shown in ISO 4210-4:2014, Figure 3 over the brake lever (or a secondary brake lever) and the handlebar grip or any other covering in at least one position between points B and C indicated in [Figure 2 c\)](#), without causing any movement of the brake lever towards the handlebar. The dimension d shall not exceed 100 mm.

Conformance shall be established by the method detailed in ISO 4210-4:2014, 4.1.2. The range of adjustment on the brake lever should permit these dimensions to be obtained.

Dimensions in millimetres

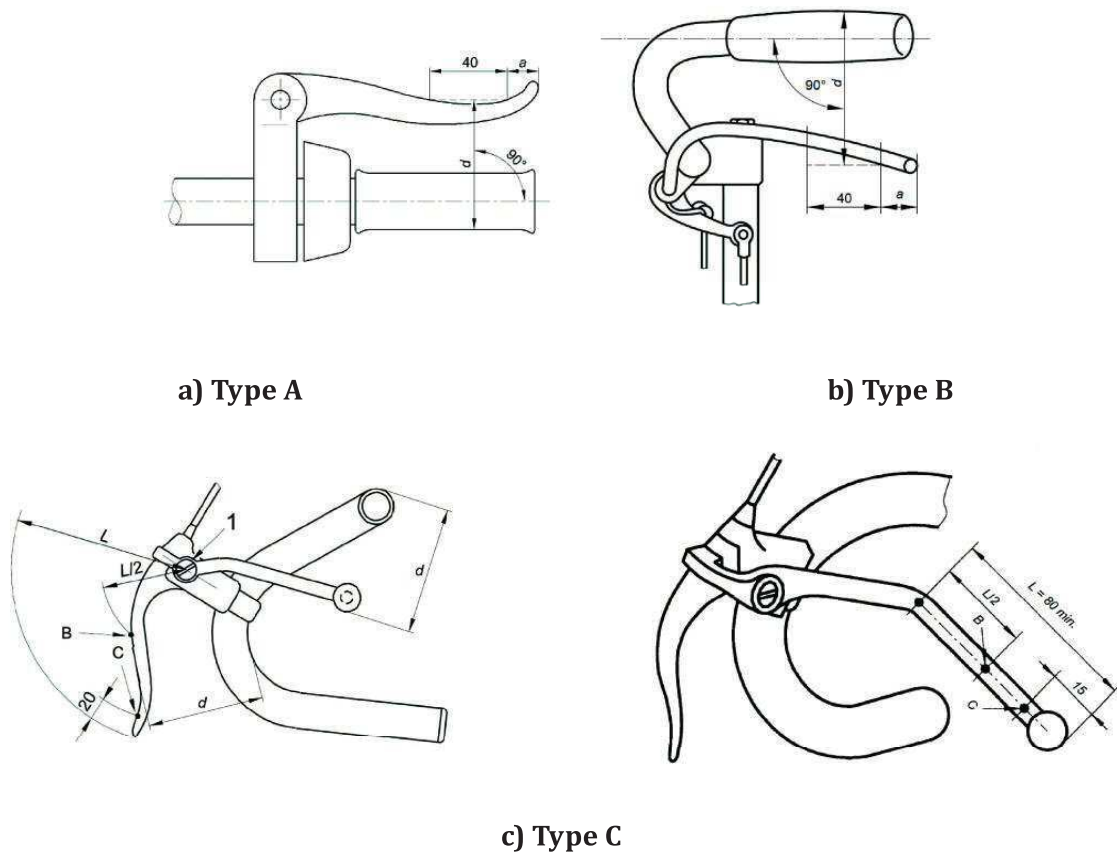

Key

- 1 pivot
- a* distance between the last part of the lever intended for contact with the rider's fingers and the end of the lever
- B* point of $L/2$
- C* point of 20 mm (in case of an extension brake lever, 15 mm) from the end of the lever
- d* brake lever grip dimension
- L* distance between the centre of the lever pivot and the lever tip end

Figure 2 — Brake lever grip dimensions

4.6.3 Attachment of brake assembly and cable requirements

Cable pinch bolts shall not sever any of the cable strands when assembled to the manufacturer's instructions. In the event of a cable failing, no part of the brake mechanism shall inadvertently inhibit the rotation of the wheel.

The cable end shall either be protected with a cap that shall withstand a removal force of not less than 20 N or be otherwise treated to prevent unravelling.

NOTE See 4.3 in relation to fasteners.

4.6.4 Brake-block and brake-pad assemblies — Security test

The friction material shall be securely attached to the holder, backing plate, or shoe and there shall be no failure of the braking system or any component thereof, and the brake shall meet the performance requirements of 4.6.8 when tested by the method specified in ISO 4210-4:2014, 4.3.

4.6.5 Brake adjustment

Each brake shall be equipped with an adjustment mechanism, either manual or automatic.

Each brake shall be capable of adjustment with or without the use of a tool to an efficient operating position until the friction material has worn to the point of requiring replacement as recommended in the manufacturer's instructions. Also, when correctly adjusted, the friction material shall not contact anything other than the intended braking surface.

The brake blocks of a bicycle with rod brakes shall not come into contact with the rim of the wheels when the steering angle of the handlebars is set at 60°, nor shall the rods bend, or be twisted after the handlebars are reset to the central position.

4.6.6 Hand-operated braking-system — Strength test

When tested by the method described in ISO 4210-4:2014, 4.4, there shall be no failure of the braking system or of any component thereof.

4.6.7 Back-pedal braking system — Strength test

4.6.7.1 General

If the back-pedal braking system is fitted, the brake shall be actuated by the operator's foot applying force to the pedal in a direction opposite to that of the drive force. The brake mechanism shall function regardless of any drive gear positions or adjustments. The differential between the drive and brake positions of the crank shall not exceed 60°.

The measurement shall be taken with the crank held against each position with a pedal force of at least 250 N. The force shall be maintained for 1 min in each position.

4.6.7.2 Requirement

When tested in accordance with ISO 4210-4:2014, 4.5, there shall be no failure of the brake system or any component thereof.

4.6.8 Braking performance

4.6.8.1 General

Two test methods are specified to determine braking performance and experience has shown that either method is suitable and either can be used. One test method is the track test in which braking distance is measured directly with the progressive characteristics of the brakes being self-evident. The alternative test method is a machine/rig base test in which braking force is measured and, from which, braking performance values are calculated. The progressive characteristics of the brake are determined by linearity measurements. A final, simple track test checks for smooth, safe, stopping characteristics.

Whichever method is used, there shall be compliance with [4.6.8.1.1](#) or [4.6.8.1.2](#).

NOTE See ISO 4210-4:2014, 4.6.5.7 item h), test method — simple track test.

4.6.8.1.1 Track test

When tested in accordance with ISO 4210-4:2014, 4.6.3, the bicycle shall fulfil the requirements shown in [Table 2](#).

Table 2 — Brake test velocities and braking distances

Bicycle type	Condition	Velocity km/h	Brake in use	Maximum corrected braking distance m
City and trekking bicycles	Dry	25	Both	7
			Rear only	15
	Wet	16	Both	5
			Rear only	10
Young adult bicycles	Dry	25	Both	7
			Rear only	15
	Wet	16	Both	5
			Rear only	10
Mountain bicycles	Dry	25	Both	6
			Rear only	10
	Wet	16	Both	5
			Rear only	10
Racing bicycles	Dry	25	Both	6
			Rear only	12
	Wet	16	Both	5
			Rear only	10

4.6.8.1.2 Machine test

When tested in accordance with ISO 4210-4:2014, 4.6.5, the bicycle shall fulfil the requirements shown in [Table 3](#).

Table 3 — Calculated braking performance value

Bicycle type	Condition	Brake in use	Minimum braking performance value, B_p N
City and trekking bicycles	Dry	Front only	340
		Rear only	220
	Wet	Front only	220
		Rear only	140
Young adult bicycles	Dry	Front only	204
		Rear only	132
	Wet	Front only	132
		Rear only	84
Mountain bicycles	Dry	Front only	425
		Rear only	280
	Wet	Front only	220
		Rear only	140
Racing bicycles	Dry	Front only	425
		Rear only	260
	Wet	Front only	220
		Rear only	140

4.6.8.2 Smooth, safe-stop characteristics

The bicycle shall show smooth, safe-stop characteristics with regard to the intended use of the bicycle and the ability of the expected user of the bicycle.

- a) For the track test, smooth, safe-stop characteristics are defined as stopping within the required distances without occurrence of any of the following:
- 1) excessive juddering;
 - 2) front wheel locking;
 - 3) bicycle overturning (rear wheel lifting uncontrollably);
 - 4) rider's loss of control;
 - 5) excessive side-skid causing the rider to put his foot to the ground to retain control.

With certain types of braking system, it might not be possible to avoid entirely some skidding of the rear wheel during braking; this is considered acceptable provided that item 4) or item 5) above do not occur as a result.

Back pedal brakes shall additionally comply with the linearity test of ISO 4210-4:2014, 4.6.4.

- b) For the machine test, smooth, safe-stop characteristics are defined by compliance with the linearity requirements specified in ISO 4210-4:2014, 4.6.5.3 and the simple track test described in ISO 4210-4:2014, 4.6.5.7 item h).

4.6.8.3 Ratio between wet and dry braking performance

For city and trekking, young adult, and mountain bicycles, in order to ensure safety for both wet and dry braking, the ratio of braking performance wet/dry shall be greater than 4:10.

The methods for calculating this ratio are given in ISO 4210-4:2014, 4.6.3.11 item c) for the track test and in ISO 4210-4:2014, 4.6.5.7 item g) for the machine test.

NOTE [4.6.8.3](#) is not applicable to racing bicycles.

4.6.9 Brakes — Heat-resistance test

4.6.9.1 General

This test applies to all disc and hub brakes, but it applies to rim brakes only where they are known or suspected to be manufactured from or include thermoplastic materials.

Each brake on the bicycle shall be tested individually, but where the front and rear brakes are identical, only one brake needs to be tested.

4.6.9.2 Requirement

Throughout the test described in ISO 4210-4:2014, 4.7, the brake lever shall not touch the handlebar grip, the operating force shall not exceed 180 N, and the braking force shall not deviate outside the range 60 N to 115 N.

Immediately after having been subjected to the test described in ISO 4210-4:2014, 4.7, the brakes shall achieve at least 60 % of the braking performance which was recorded at the highest operating force used during the performance tests ISO 4210-4:2014, 4.6.5.7 c) items 1) and 2).

4.7 Steering

4.7.1 Handlebar — Dimensions

The handlebar shall have an overall width between 350 mm and 1 000 mm unless national regulations dictate otherwise. Adjust the handlebar height to its highest normal riding position and the saddle to its lowest normal riding position as specified by the manufacturer [see [Clause 5](#), item c)]. Measure the vertical distance from the centre and top of the handlebar grips to a point where the saddle surface is intersected by the seat post axis (see [Figure 3](#)). This dimension shall not exceed 400 mm.

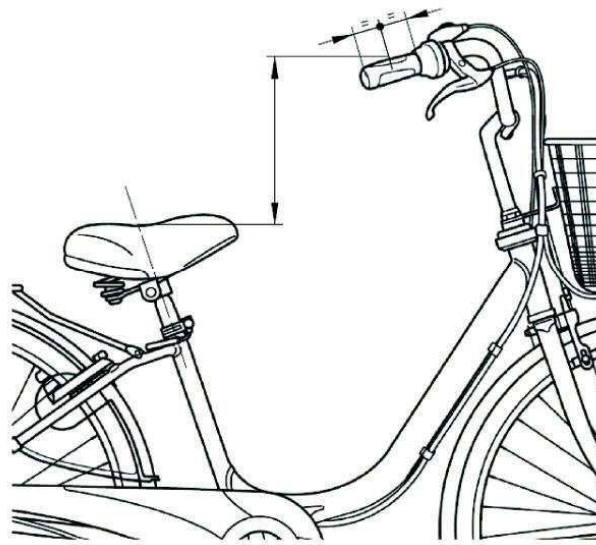

Figure 3 — Vertical distance between the handlebar grips and the seat surface

4.7.2 Handlebar grips and plugs

The ends of the handlebar shall be fitted with handgrips or end plugs. When tested by the method described in ISO 4210-5:2014, 4.1.1 and 4.1.2, the handgrips or plugs shall withstand the specified removal forces.

4.7.3 Handlebar stem — Insertion-depth mark or positive stop

The handlebar stem shall be provided with one of the two following alternative means of ensuring a safe insertion depth into the fork steerer.

- a) It shall contain a permanent, transverse mark, of length not less than the external diameter of the stem that clearly indicates the minimum insertion depth of the handlebar stem into the fork steerer. The insertion mark shall be located at a position not less than 2,5 times the external diameter of the handlebar stem from the bottom of the stem, and there shall be at least one stem diameter's length of contiguous, circumferential stem material below the mark.
- b) It shall incorporate a permanent stop to prevent it from being drawn out of the fork steerer such as to leave the insertion less than the amount specified in item a).

4.7.4 Handlebar stem to fork steerer — Clamping requirements

The distance g (see [Figure 4](#)) between the top of the handlebar stem and the top of the fork steerer to which the handlebar stem is clamped shall not be greater than 5 mm.

The upper part of the fork steerer to which the handlebar stem is clamped shall not be threaded.

The dimension g shall also ensure that the proper adjustment of the steering system can be achieved.

NOTE For aluminium and composite fork steerer, the avoidance of any internal device that could damage the internal surface of the fork steerer is recommended.

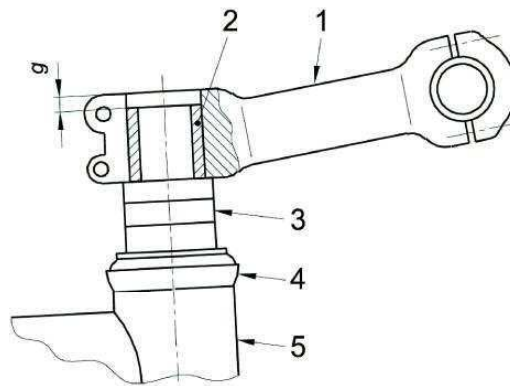

Key

- g* distance between the upper clamping part of the handlebar stem and the upper part of the fork steerer
- 1 handlebar stem
- 2 extended fork steerer
- 3 spacer rings
- 4 head set
- 5 head tube

Figure 4 — Clamping between the handlebar stem and fork steerer

4.7.5 Steering stability

The steering shall be free to turn through at least an angle of θ_1 either side of the straight-ahead position and shall exhibit no tight spots, stiffness, or slackness in the bearings when correctly adjusted. The values are given in [Table 4](#).

A minimum of 25 % of the total mass of the bicycle and rider shall act on the front wheel when the rider is holding the handlebar grips and sitting on the saddle, with the saddle and rider in their most rearward positions.

NOTE Recommendations for steering geometry are given in [Annex A](#).

Table 4 — Values of steering angle

Angles in degrees

Bicycle type	City and trekking bicycles	Young adult bicycles	Mountain bicycles	Racing bicycles
Steering angle θ_1	60	60	30	30

4.7.6 Steering assembly — Static strength and security tests

4.7.6.1 Handlebar stem — Lateral bending test

4.7.6.1.1 General

This test is intended for stem manufacturers who do not produce handlebars.

4.7.6.1.2 Requirement

When tested by the method described in ISO 4210-5:2014, 4.2, there shall be no cracking or fracture of the stem and the permanent deformation measured at the point of application of the test force and in the direction of the test force shall not exceed 10 mm.

Handlebar stems can influence test failures of handlebars but handlebars do not usually influence test failures of stems. For these reasons, a handlebar is always to be tested mounted on a stem but stems can be tested with a solid bar in place of a handlebar.

4.7.6.2 Handlebar and stem assembly — Lateral bending test

4.7.6.2.1 General

This test is for manufacturers who produce handlebars and stems or for cycle manufacturers.

4.7.6.2.2 Requirement

When tested by the method described in ISO 4210-5:2014, 4.3, there shall be no cracking or fracture of the handlebar, stem, or clamp-bolt and the permanent deformation measured at the point of application of the test force shall not exceed 15 mm.

4.7.6.3 Handlebar-stem — Forward bending test

4.7.6.3.1 General

Conduct the test in two stages on the same assembly as follows.

4.7.6.3.2 Requirement for stage 1

When tested by the method described in ISO 4210-5:2014, 4.4.1, there shall be no visible cracks or fractures and the permanent deformation measured at the point of application of the test force and in the direction of the test force shall not exceed 10 mm.

4.7.6.3.3 Requirement for stage 2

When tested by the method described in ISO 4210-5:2014, 4.4.2, there shall be no visible cracks or fractures.

4.7.6.4 Handlebar to handlebar stem — Torsional security test

When tested by the method described in ISO 4210-5:2014, 4.5, there shall be no movement of the handlebar relative to the handlebar stem.

4.7.6.5 Handlebar stem to fork steerer — Torsional security test

When tested by the method described in ISO 4210-5:2014, 4.6, there shall be no movement of the handlebar stem relative to the fork steerer.

4.7.6.6 Bar end to handlebar — Torsional security test

When tested by the method described in ISO 4210-5:2014, 4.7, there shall be no movement of the bar end in relation to the handlebar.

4.7.6.7 Aerodynamic extensions to handlebar — Torsional security test

When a handlebar is suitable for use with aerodynamic extensions, the extension/handlebar/handlebar stem assembly shall withstand the following security test.

When tested by the method described in ISO 4210-5:2014, 4.8, there shall be no movement of the extension in relation to the handlebar and of the handlebar in relation to the handlebar stem.

4.7.7 Handlebar and stem assembly — Fatigue test

4.7.7.1 General

Handlebar stems can influence test failures of handlebars and, for this reason, a handlebar shall always be tested mounted on a stem, but it is permitted to test a stem with a solid bar in place of the handlebar and bar ends with dimensions corresponding to handlebars/bar ends suitable for that stem.

When the fatigue test is for the stem only, the manufacturer of the stem shall specify the types and sizes of handlebar for which the stem is intended and the test shall be based on the most severe combination.

Conduct the test in two stages on the same assembly.

4.7.7.2 Requirement for stage 1 and stage 2

When tested by the method described in ISO 4210-5:2014, 4.9.1 or 4.9.2, there shall be no visible cracks or fractures in any part of the handlebar and stem assembly or any bolt failure.

For composite handlebars or stems, the running displacements (peak-to-peak value) at the points where the test forces are applied shall not increase by more than 20 % of the initial values.

4.8 Frames

4.8.1 Suspension-frames — Special requirements

The design shall be such that if the spring or damper fails, the tyre shall not contact any part of the frame or the assembly carrying the rear wheel shall become detached from the rest of the frame.

NOTE See ISO 4210-6:2015, Annex C.

4.8.2 Frame — Impact test (falling mass)

When tested by the method described in ISO 4210-6:2015, 4.1, there shall be no visible cracks or fractures of the frame.

The permanent deformation measured between the axis of the wheel axles (the wheelbase, see ISO 4210-6:2015, 4.1 and Figure 1) shall not exceed the following values:

- a) 30 mm where a fork is fitted;
- b) where a dummy fork is fitted in place of a fork, the values are given in [Table 5](#).

NOTE See ISO 4210-6:2015, Annex A.

Table 5 — Values of permanent deformation (falling mass)

Dimensions in millimetres

Bicycle type	City and trekking bicycles	Young adult bicycles	Mountain bicycles	Racing bicycles
Permanent deformation	10	10	10	15

4.8.3 Frame and front fork assembly — Impact test (falling frame)

When tested by the method described in ISO 4210-6:2015, 4.2, there shall be no visible cracks or fractures in the assembly, and after the second impact, there shall be no separation of any parts of any suspension system. The permanent deformation measured between the axis of the wheel axles shall not exceed the values specified in [Table 6](#).

Table 6 — Values of permanent deformation (falling frame)

Dimensions in millimetres

Bicycle type	City and trekking bicycles	Young adult bicycles	Mountain bicycles	Racing bicycles
Permanent deformation	60	60	60	15

4.8.4 Frame — Fatigue test with pedalling forces

When tested by the method described in ISO 4210-6:2015, 4.3, there shall be no visible cracks or fractures in any part of the frame and there shall be no separation of any parts of the suspension system.

For composite frames, the running displacements (peak-to-peak values) at the points where the test forces are applied shall not increase by more than 20 % of the initial values (see ISO 4210-3:2014, 4.6).

4.8.5 Frame — Fatigue test with horizontal forces

When tested by the method described in ISO 4210-6:2015, 4.4, there shall be no visible cracks or fractures in the frame and there shall be no separation of any parts of any suspension system.

For composite frames, the running displacement (peak-to-peak value) at the point where the test forces are applied shall not increase by more than 20 % of the initial values (see ISO 4210-3:2014, 4.6).

4.8.6 Frame — Fatigue test with a vertical force

When tested by the method described in ISO 4210-6:2015, 4.5, there shall be no visible cracks or fractures in the frame and there shall be no separation of any parts of the suspension system.

For composite frames, the running displacement (peak-to-peak value) at the point where the test forces are applied shall not increase by more than 20 % of the initial value (see ISO 4210-3:2014, 4.6).

4.9 Front fork

4.9.1 General

[4.9.2](#), [4.9.4](#), [4.9.5](#), and [4.9.6](#) apply to all types of fork.

In the strength tests in [4.9.4](#), [4.9.5](#), [4.9.6](#), and [4.9.7](#), a suspension fork shall be tested in its free, uncompressed length condition.

4.9.2 Means of location of the axle and wheel retention

The slots or other means of location for the wheel axle within the front fork shall be such that when the axle or cones are firmly abutting the top face of the slots, the front wheel remains central within the fork.

The front fork and wheel shall also fulfil the requirements of [4.10.4](#) and [4.10.5](#).

4.9.3 Suspension forks — Special requirements

4.9.3.1 Tyre clearance test

When tested by the method described in ISO 4210-6:2015, 5.1, the tyre shall not contact the crown of the fork, nor shall the components separate.

4.9.3.2 Tensile test

When tested by the method described in ISO 4210-6:2015, 5.2, there shall be no detachment or loosening of any parts of the assembly and the tubular, telescopic components of any fork-leg shall not separate under the test force.

4.9.4 Front fork — Static bending test

When tested by the method described in ISO 4210-6:2015, 5.3, there shall be no fractures or visible cracks in any part of the fork, and the permanent deformation, measured as the displacement of the axis of the wheel axle, or simulated axle in relation to the axis of the fork steerer, shall not exceed 10 mm.

4.9.5 Front fork — Rearward impact test

4.9.5.1 Forks made entirely of metal

When tested by the method described in ISO 4210-6:2015, 5.4.1, if there are any fractures or visible cracks in any part of the fork, and the permanent deformation, measured as the displacement of the axis of the wheel axle or simulated axle in relation to the axis of the fork steerer, exceeds 45 mm, the fork shall be considered to have failed.

If the fork meets the first test criteria, then, it shall be subjected to a second test as described in ISO 4210-6:2015, 5.4.2, after which it shall exhibit no fractures. If the fork meets the first and second test criteria, then, it shall be subjected to a third test as described in ISO 4210-6:2015, 5.4.3, irrespective of the amount of permanent deformation, there shall be no relative movement between the steerer and the crown.

4.9.5.2 Forks which have composite parts

When tested by the method described in ISO 4210-6:2015, 5.4.1, there shall be no fractures in any part of a fork, and the permanent deformation, measured as the displacement of the axis of the wheel axle or simulated axle in relation to the axis of the fork steerer, shall not exceed 45 mm. If the fork meets the first test criteria, then it shall be subjected to a second test as described in ISO 4210-6:2015, 5.4.3. In the case of torque on fork, irrespective of the amount of permanent deformation, there shall be no relative movement between the steerer and the crown.

4.9.6 Front fork — Bending fatigue test plus rearward impact test

When tested by the method described in ISO 4210-6:2015, 5.5, there shall be no fractures in any part of the fork, and the permanent deformation, measured as the displacement of the axis of the wheel axle or simulated axle in relation to the axis of the fork steerer, shall not exceed 45 mm.

For composite forks, the running displacement (peak-to-peak value) at the points where the test forces are applied shall not increase by more than 20 % for rigid forks or more than 40 % for suspension forks from the initial values (see ISO 4210-3:2014, 4.6).

4.9.7 Forks intended for use with hub- or disc-brakes

4.9.7.1 Static brake-torque test

When tested by the method described in ISO 4210-6:2015, 5.6.2, there shall be no fractures or visible cracks in any part of the fork.

4.9.7.2 Fork for hub/disc-brake — Brake mount fatigue test

When tested by the method described in ISO 4210-6:2015, 5.6.3, there shall be no fractures or visible cracks in any part of the fork and, in the case of suspension forks, there shall be no separation of any parts.

4.9.8 Tensile test for a non-welded fork

4.9.8.1 General

This test is for forks where the blades and/or the fork steerer are secured in the fork-crown by press-fitting, clamping, adhesives, or any method other than brazing or welding. It can be convenient to combine this test with the wheel retention test in [4.10.4](#).

4.9.8.2 Requirement

When tested by the method described in ISO 4210-6:2015, 5.7, there shall be no detachment or loosening of any parts of the assembly.

4.10 Wheels and wheel/tyre assembly

4.10.1 Wheels/tyre assembly — Concentricity tolerance and lateral tolerance

When measured by the method described in ISO 4210-7:2014, 4.1, the run-out shall not exceed the values which are given in [Table 7](#).

Table 7 — Wheel/tyre assembly — Concentricity and lateral tolerance

Dimensions in millimetres

Bicycle type		City and trekking bicycles	Young adult bicycles	Mountain bicycles	Racing bicycles
Concentricity and lateral tolerance	Intended for rim-brakes	1	1	1	0,7
	Not intended for rim-brakes	2	2	2	

4.10.2 Wheel/tyre assembly — Clearance

Alignment of the wheel assembly in a bicycle shall allow not less than the clearance values given in [Table 8](#) between the tyre and any frame or fork element or a front mudguard and its attachment bolts.

Table 8 — Wheel/tyre assembly — Clearance

Dimensions in millimetres

Bicycle type	City and trek-king bicycles	Young adult bicycles	Mountain bicycles	Racing bicycles
Clearance	6	6	6	4

NOTE Where a bicycle has a frame or a fork with a suspension system, the values in [Table 8](#) apply to the suspension system in its uncompressed state. Clearance requirements for the frame or fork under a load are specified in ISO 4210-6:2015, Annex C and 4.9.3.1.

4.10.3 Wheel/tyre assembly — Static strength test

When tested by the method described in ISO 4210-7:2014, 4.2, there shall be no failure of any of the components of the wheel, and the permanent deformation, measured at the point of application of the force on the rim, shall not exceed the values which are given in [Table 9](#).

Table 9 — The values of permanent deformation

Dimensions in millimetres

Bicycle type	City and trek-king bicycles	Young adult bicycles	Mountain bicycles	Racing bicycles
Permanent deformation	1,5	1,5	1,0	1,0

4.10.4 Wheels — Wheel retention

4.10.4.1 General

Wheel retention safety is related to the combination of wheel, retention device, and drop-out design.

Wheels shall be secured to the bicycle frame and fork such that when adjusted to the manufacturer's instructions they comply with [4.10.4.2](#), [4.10.4.3](#), and [4.10.5](#).

Wheel nuts shall have a minimum removal torque of 70 % of the manufacturer's recommended tightening torque.

Where quick-release axle devices are used they shall comply with [4.10.5](#).

4.10.4.2 Wheel retention — Retention devices secured

When tested by the method described in ISO 4210-7:2014, 4.3, there shall be no relative motion between the axle and the front fork/frame.

4.10.4.3 Front wheel retention — Retention devices unsecured

A bicycle shall be equipped with secondary retention system that retains the front wheel in the drop-outs when the primary retention system is in the open (unlocked) position.

Where threaded axles and nuts are fitted, and the nuts are unscrewed by at least 360° from the finger tight condition and the brake system is disconnected or released, the wheel shall not detach from the front fork when a force of 100 N is applied radially outwards, in line with the drop-out slots, and maintained for 1 min.

Where quick-release is fitted, and the quick-release lever is fully open and the brake system is disconnected or released, the wheel shall not detach from the front fork when a force of 100 N is applied to the wheel radially outwards, in line with the drop-out slots, and maintained for 1 min.

4.10.5 Wheels — Quick-release devices — Operating features

Any quick-release device shall have the following operating features:

- a) it shall be adjustable to allow setting for tightness;
- b) its form and marking shall clearly indicate whether the device is in the open or locked position;
- c) if adjustable by a lever, the force required to close a properly set lever shall not exceed 200 N and, at this closing force, there shall be no permanent deformation of the quick-release device;
- d) the releasing force of the clamping device when closed shall not be less than 50 N;
- e) if operated by a lever, the quick-release device shall withstand without fracture or permanent deformation a closing force of not less than 250 N applied with the adjustment set to prevent closure at this force;
- f) the wheel retention with the quick-release device in the clamped position shall be in accordance with [4.10.4.2](#);
- g) the front wheel retention with the quick-release device in the open position shall be in accordance with [4.10.4.3](#).

If applied to a lever, the forces specified in items c), d), and e) shall be applied 5 mm from the tip end of the lever.

4.11 Rims, tyres, and tubes

4.11.1 General

Non-pneumatic tyres are excluded from the requirements of [4.11.2](#), [4.11.3](#), and [4.11.4](#).

NOTE For wheel/tyre assembly fatigue test for city and trekking bicycles, see ISO 4210-7:2014, Annex A.

4.11.2 Tyre inflation pressure

The maximum inflation pressure recommended by the manufacturer shall be permanently marked on the side wall of the tyre so as to be readily visible when the latter is assembled on the wheel. If the rim manufacturer recommends a maximum tyre inflation pressure, it shall be clearly and permanently marked on the rim and also specified in the manufacturer's instructions.

NOTE It is recommended that the minimum inflation pressure specified by the tyre manufacturer also be permanently marked on the side wall of the tyre.

4.11.3 Tyre and rim compatibility

Tyres that comply with the requirements of ISO 5775-1 and rims that comply with the requirements of ISO 5775-2 are compatible. The tyre, tube, and tape shall be compatible with the rim design. When inflated to 110 % of the maximum inflation pressure, determined by the lower value between maximum inflation pressures recommended on the rim or the tyre, for a period of not less than 5 min, the tyre shall remain intact on the rim.

NOTE In the absence of suitable information from the above-mentioned International Standards, other publications can be used. See Reference [\[9\]](#) and Reference [\[10\]](#).

4.11.4 Tubular tyres and rims

Tubular tyres shall be compatible with the rim design. Instructions for the correct gluing technique shall be given in the bicycle or the wheel assembly instructions of the manufacturer's instructions [see [Clause 5](#), item v)].

4.11.5 Rim-wear

In the case where the rim forms part of a braking system and there is a danger of failure due to wear, the manufacturer shall make the rider aware of this danger by durable and legible marking on the rim, in an area not obscured by the tyre [see [Clause 5](#), item u) and [6.2](#)].

NOTE A symbol referring to the instruction manual is an acceptable marking for rims for wear.

Where the rim is made of composite materials, the manufacturer shall include in the manufacturer's instructions warnings of the danger of rim failure caused by wear of the braking surfaces.

4.11.6 Greenhouse effect test for composite wheels

4.11.6.1 General

This requirement is to ensure wheels made from composite materials that are subjected to high temperature conditions (i.e. such as car storage in direct sunlight) do not suffer concealed damage that could subsequently affect the safety performance of the wheel during normal use.

4.11.6.2 Requirement

When a fully assembled wheel made of composite material, fitted with the appropriate size tyre and inflated according to the lower value between maximum inflation pressure recommended on the rim or the tyre, is tested by the method described in ISO 4210-7:2014, 4.4, there shall be

- no failure of any of the components of the wheel,
- no tyre separation from the rim during the test,
- no increase in rim width greater than 5 % of the initial maximal width value,
- compliance of lateral and concentricity tolerance according to [4.10.1](#),
- compliance of tyre and rim compatibility according to [4.11.3](#), and
- compliance of static strength according to [4.10.3](#).

4.12 Front mudguard

If the front mudguard is fitted, when tested by the method described in the two-stage tests in ISO 4210-3:2014, 4.2.1 (for mudguard with stays) or 4.2.2 (for mudguard without stays), the front mudguard shall not prevent rotation of the wheel or shall obstruct the steering.

4.13 Pedals and pedal/crank drive system

4.13.1 Pedal tread

4.13.1.1 Tread surface

The tread surface of a pedal shall be secured against movement within the pedal assembly.

4.13.1.2 Toe clips

Pedals intended to be used without toe clips, or for optional use with toe clips, shall have

- a) tread surfaces on the top and bottom surfaces of the pedal, or
- b) a definite preferred position that automatically presents the tread surface to the rider's foot.

4.13.1.3 Pedals designed to be used only with toe clips or shoe-retention devices shall have toe clips or shoe-retention devices securely attached and need not comply with the requirements of 4.13.1.2, items a) and b).

4.13.2 Pedal clearance

4.13.2.1 Ground clearance

With the bicycle unladen, the pedal at its lowest point and the tread surface of the pedal parallel to the ground and uppermost where it has only one tread surface, the bicycle shall be capable of being leaned over at an angle of θ_2 from the vertical before any part of the pedal touches the ground. The values are given in Table 10.

When a bicycle is equipped with a suspension system, this measurement shall be taken with the suspension adjusted to the softest condition and with the bicycle depressed into a position such as would be caused by a rider weighing 80 kg (in case of young adult bicycles, apply 40 kg).

Table 10 — The values of ground clearance

Angles in degrees

Bicycle type	City and trekking bicycles	Young adult bicycles	Mountain bicycles	Racing bicycles
Lean angle θ_2	25	23	25	23

4.13.2.2 Toe clearance

Bicycles shall have at least C clearance between the pedal and front tyre or mudguard (when turned to any position). The clearance shall be measured forward and parallel to the longitudinal axis of the bicycle from the centre of either pedal axle to the arc swept by the tyre or mudguard, whichever results in the least clearance (see Figure 5). The values are given in Table 11.

Table 11 — The values of toe clearance

Dimensions in millimetres

Bicycle type		City and trekking bicycles	Young adult bicycles	Mountain bicycles	Racing bicycles
Toe clearance, C	without foot retention	100	89	100	100
	with foot retention	89	89	89	89

NOTE Foot retention system, e.g. quick-release pedal or toe-clip.

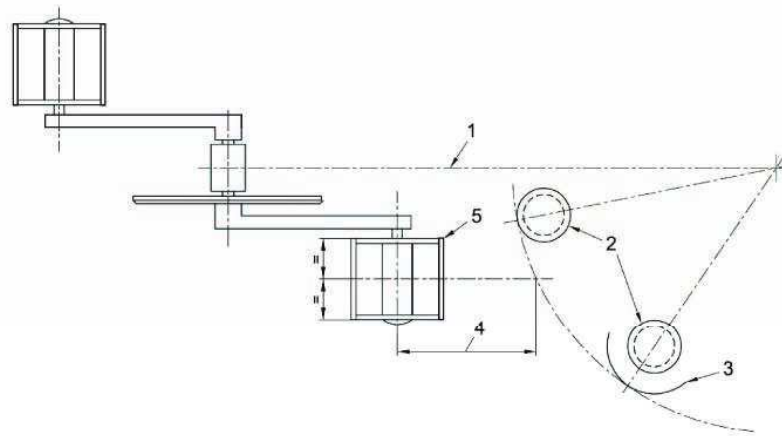
**Key**

- 1 longitudinal axis
- 2 front tyre
- 3 mudguard
- 4 clearance, *C*
- 5 pedal

Figure 5 — Toe clearance — Pedal to wheel/mudguard

4.13.3 Pedal — Static strength test

When tested by the method described in ISO 4210-8:2014, 4.1, there shall be no fractures, visible cracks, or distortion of the pedal or spindle that could affect the operation of the pedal and pedal spindle.

4.13.4 Pedal — Impact test

When tested by the method described in ISO 4210-8:2014, 4.2, there shall be no fractures of any part of the pedal body, the pedal spindle, or any failure of the bearing system.

4.13.5 Pedal — Dynamic durability test

When tested by the method described in ISO 4210-8:2014, 4.3, there shall be no fractures or visible cracking of any part of the pedal, the pedal spindle, or any failure of the bearing system.

4.13.6 Drive system — Static strength test

a) Drive system with chain

When tested by the method described in ISO 4210-8:2014, 4.4.1, there shall be no fracture of any component of the drive system and drive capability shall not be lost.

b) Drive system with belt

When tested by the method described in ISO 4210-8:2014, 4.4.2, there shall be no fracture of any component of the drive system and the belt shall not slip/skip, fracture, or cause any loss in drive capability.

Smooth sliding between pulleys and belt is allowed at a rate not exceeding 1°/s at the drive axis.

4.13.7 Crank assembly — Fatigue test

4.13.7.1 Requirement

When tested by the method described in ISO 4210-8:2014, 4.6.2, there shall be no fractures or visible cracks in the cranks, the bottom-bracket spindle, or any of the attachment features, or loosening or detachment of the chain wheel from the crank.

For composite cranks, the running displacements (peak-to-peak values) of either crank at the point where the test forces are applied shall not increase by more than 20 % of the initial value (see ISO 4210-3:2014, 4.6).

4.13.7.2 Special requirements for mountain bicycles

For mountain bicycles, two types of fatigue test are specified, one with the cranks positioned at 45° to the horizontal to simulate the forces due to pedalling, and the second test with the cranks positioned at 30° to the horizontal, which has been found to simulate the forces due to the rider standing on the pedals during the descent of hills. The two tests shall be conducted on separate assemblies.

When tested by the method described in ISO 4210-8:2014, 4.6.3, there shall be no fractures or visible cracks in the cranks, the bottom-bracket spindle or any of the attachment features, or loosening or detachment of the chain wheel from the crank.

For composite cranks, the running displacements (peak-to-peak values) of either crank at the point where the test forces are applied shall not increase by more than 20 % of the initial value (see ISO 4210-3:2014, 4.6).

4.14 Drive-chain and drive belt

4.14.1 Drive-chain

Where a chain-drive is used as a means of transmitting the motive force, the chain shall operate over the front and rear sprockets without binding.

The chain shall conform to the tensile strength and push-out force requirements of ISO 9633.

4.14.2 Drive belt

Where a belt-drive is used as a means of transmitting the motive force, the drive belt shall operate over the front and rear pulleys without binding. When tested by the methods described in ISO 4210-8:2014, 4.5, there shall be no evidence of cracking, fracture, or delamination of the belt drive.

4.15 Chain-wheel and belt-drive protective device

4.15.1 Requirements

City and trekking and young adult bicycles shall be equipped with one of the following:

- a) a chain wheel disc or drive pulley disc which conforms to [4.15.2](#), or
- b) a chain and drive belt protective device which conforms to [4.15.3](#), or
- c) where fitted with positive foot-retention devices on the pedals, a combined front gear-change guide which conforms to [4.15.4](#) shall be used.

Mountain and racing bicycles can be equipped with one of the above-mentioned.

4.15.2 Chain-wheel disc and drive pulley disc diameter

A chain-wheel disc shall exceed the diameter of the outer chain wheel, when measured across the tips of the teeth, by not less than 10 mm (see [Figure 6](#)).

A drive pulley disc shall exceed the diameter of the front pulley, when measured across the tips of the teeth, by not less than 10 mm (see [Figure 7](#)). Where the design is such that the crank and chain wheel or the crank and front pulley are too close together to accommodate a full disc, a partial disc can be fitted which closely abuts the crank.

Dimensions in millimetres

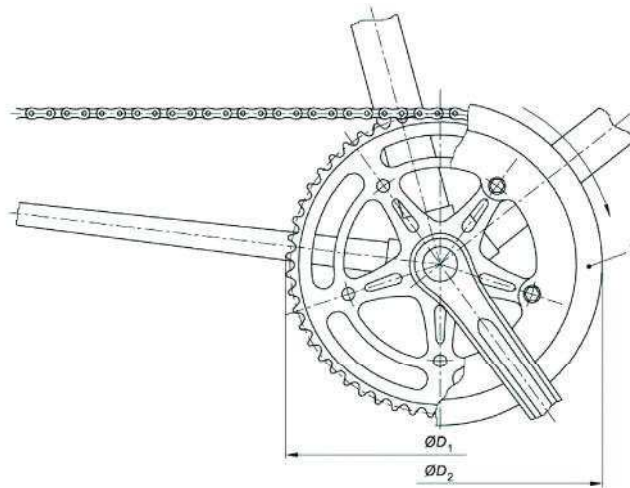

Key

- 1 chain-wheel disc ($D_2 \geq D_1 + 10$)

Figure 6 — Chain-wheel disc

Dimensions in millimetres

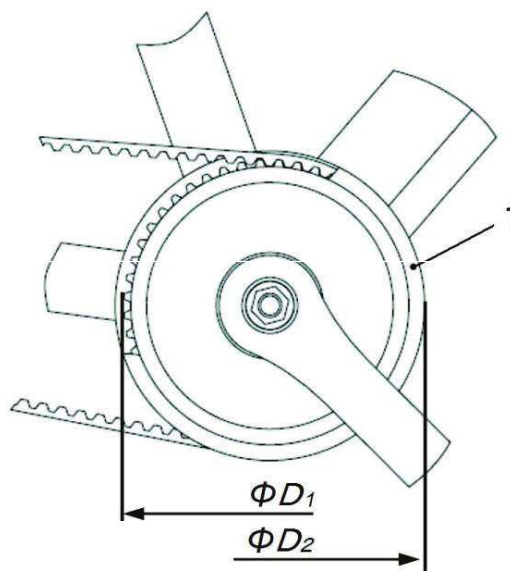

Key

- 1 drive pulley disc ($D_2 \geq D_1 + 10$)

Figure 7 — Drive pulley disc

4.15.3 Chain and drive belt protective device

A chain protective device shall, as a minimum, shield the side plates and top surface of the chain and the chain wheel for a distance of at least 25 mm rearwards along the chain from the point where the chain wheel teeth first pass between the side plates of the chain, and forwards round the outer chain wheel to a horizontal line passing through the bottom-bracket axle centre [see [Figure 8 a](#)].

A drive belt protective device shall, as a minimum, shield the side and top surface of the drive belt and the front pulley for a distance of at least 25 mm rearwards along the drive belt from the point where the tip circle of the pulley [[Figure 8 b](#)], circle *B*] is intersected by the tip line of the belt [[Figure 8 b](#)], line *C*], and forwards round the front pulley to a horizontal line passing through the bottom-bracket axle centre [see [Figure 8 b](#)].

Dimensions in millimetres

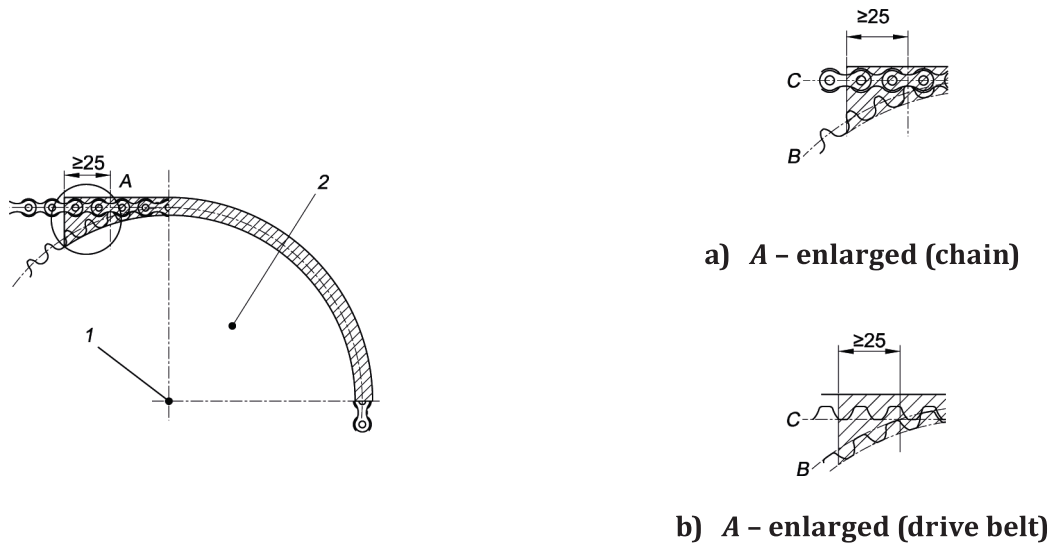

Key

- 1 bottom-bracket axle centre
- 2 chain wheel or front pulley
- B tip circle of the pulley
- C tip line of the belt

Figure 8 — Chain and drive belt protective device requirements (minimum)

4.15.4 Combined front gear-change guide

When the chain is located in the outer gear position, some portion of the combined front gear change guide shall be above the chain in the region 25 mm from the point where the chain wheel first passes between the side plates of the chain, parallel to the chain side plates in the direction towards the rear wheel of the bicycle (see [Figure 9](#)).

In addition, some portion of the combined front gear change guide shall be present below the chain in the region beyond 25 mm from the point where the chain wheel first passes between the side plates of the chain, parallel to the chain side plates in the direction towards the rear wheel of the bicycle (see [Figure 9](#)).

NOTE It is recommended that the gap between front-gear and front gear-change guide specified by the manufacturer is properly set.

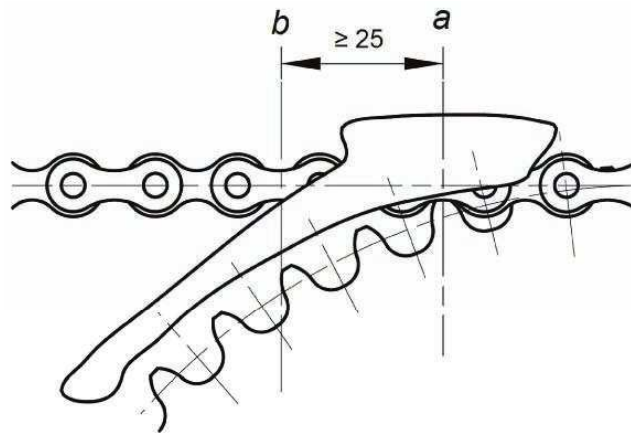
**Key**

- a* point where the chain wheel first passes between the side plates of the chain
b 25 mm rearwards from the point where the chain wheel first passes between the side plates of the chain

Figure 9 — Chain and chain-wheel junction**4.16 Saddles and seat-posts****4.16.1 Limiting dimensions**

No part of the saddle, saddle supports, or accessories to the saddle shall be more than 125 mm above the top saddle surface at the point where the saddle surface is intersected by the seat-post axis.

4.16.2 Seat-post — Insertion-depth mark or positive stop

The seat-post shall be provided with one of the two following alternative means of ensuring a safe insertion depth into the frame.

- a) It shall contain a permanent, transverse mark of length not less than the external diameter or the major dimension of the cross section of the seat-post that clearly indicates the minimum insertion depth of the seat-post into the frame. For a circular cross section, the mark shall be located not less than two diameters of the seat-post from the bottom of the seat-post (i.e. where the diameter is the external diameter). For a non-circular cross section, the insertion-depth mark shall be located not less than 65 mm from the bottom of the seat-post (i.e. where the seat-post has its full cross section).
- b) It shall incorporate a permanent stop to prevent it from being drawn out of the frame such as to leave the insertion less than the amount specified in item a) above.

4.16.3 Saddle/seat-post — Security test**4.16.3.1 Saddles with adjustment-clamps**

When tested by the method described in ISO 4210-9:2014, 4.2, there shall be no movement of the saddle adjustment clamp in any direction with respect to the seat-post, or of the seat-post with respect to the frame, or any failure of saddle, adjustment clamp, or seat-post. If the saddle design is such that it cannot accurately test the saddle/seat-post clamp, it shall be possible to use a fixture which is representative of the saddle dimensions.

4.16.3.2 Saddles without adjustment clamps

Saddles that are not clamped, but are designed to pivot in a vertical plane with respect to the seat-post, shall be allowed to move within the parameters of the design and shall withstand the tests described in ISO 4210-9:2014, 4.2 without failure of any components.

4.16.4 Saddle — Static strength test

When tested by the method described in ISO 4210-9:2014, 4.3, the saddle cover and/or plastic moulding shall not disengage from the chassis of the saddle, and there shall be no cracking or permanent distortion of the saddle assembly.

4.16.5 Saddle and seat-post clamp — Fatigue test

When tested by method described in ISO 4210-9:2014, 4.4, there shall be no fractures or visible cracks in the seat-post or in the saddle, and no loosening of the clamp.

4.16.6 Seat-post — Fatigue test

Conduct the test in two stages on the same assembly as per [4.16.6.1](#) and [4.16.6.2](#).

4.16.6.1 Requirement for stage 1

4.16.6.1.1 Seat-post without suspension system

When tested by the method described in ISO 4210-9:2014, 4.5.2, there shall be no visible cracks or fractures in the seat-post, or any bolt failure.

For composite seat-post, the running displacement (peak-to-peak value) at the point where the test forces are applied shall not increase by more than 20 % of the initial value (see ISO 4210-3:2014, 4.6).

4.16.6.1.2 Seat-post with suspension system

When tested by the method described in ISO 4210-9:2014, 4.5.2, there shall be no visible cracks or fractures in the seat-post, or any bolt failure. The design shall be such that in the event of failure of the suspension system, the two main parts do not separate, nor does the upper part (i.e. the part to which the saddle would be attached) become free to swivel in the lower part.

4.16.6.2 Requirement for stage 2

4.16.6.2.1 Seat-post without suspension system

When tested by the method described in ISO 4210-9:2014, 4.5.3, there shall be no fractures and the displacement shall not exceed 10 mm during testing.

4.16.6.2.2 Seat-post with suspension system

When tested by the method described in ISO 4210-9:2014, 4.5.3, there shall be no fractures. The design shall be such that in the event of failure of the suspension system, the two main parts do not separate, nor does the upper part (i.e. the part to which the saddle would be attached) become free to swivel in the lower part.

4.17 Spoke protector

Bicycles for young adults as well as city and trekking bicycles with multiple free-wheel/cassette sprockets shall be fitted with a spoke-protector guard to prevent the chain from interfering with or

stopping rotation of the wheel through improper adjustment or damage. All other types of bicycles covered by this part of ISO 4210 can be fitted with a spoke protector.

4.18 Luggage carriers

If luggage carriers are fitted or provided, they shall comply with ISO 11243.

4.19 Road test of a fully assembled bicycle

When tested by the method described in ISO 4210-3:2014, 4.3, there shall be no system or component failure and no loosening or misalignment of the saddle, handlebar, controls, or reflectors.

The bicycle shall exhibit stable handling in braking, turning, and steering, and it shall be possible to ride with one hand removed from the handlebar (as when giving hand signals), without difficulty of operation or hazard to the rider. If the bicycle is fitted with a luggage carrier, the test shall be carried out with the maximum load capacity indicated on the luggage carrier.

NOTE 1 See also ISO 4210-4:2014, 4.6.5.7 item h), test method — simple track test.

NOTE 2 For structural integrity of a fully assembled bicycle, see ISO 4210-3:2014, Annex A.

4.20 Lighting systems and reflectors

4.20.1 General

Bicycles shall be equipped with reflectors at the front, rear, and side. Bicycles shall be equipped with lighting systems and reflectors in conformity with the national regulations in the country in which the bicycle is marketed, because national regulations for lighting systems and reflectors differ from country to country.

4.20.2 Wiring harness

When a wiring harness is fitted, it shall be positioned to avoid any damage by contact with moving parts or sharp edges. All connections shall withstand a tensile force in any direction of 10 N.

4.20.3 Lighting systems

The lighting system consists of a front and a rear light. These devices shall comply with the provisions in force in the country in which the product is marketed. If there are no forced provisions of these devices, the lighting system shall comply with the requirements of ISO 6742-1.

4.20.4 Reflectors

These devices shall comply with the provisions in force in the country in which the product is marketed. If there are no forced provisions of these devices, the retro-reflective devices shall comply with the requirements of ISO 6742-2.

4.20.4.1 Rear reflectors

Rear reflectors shall be red in colour.

4.20.4.2 Side reflectors

The retro reflective device(s) shall be either

- a) reflectors fitted on the front half and on the rear half of the bicycle. At least one of these shall be mounted on the spokes of the wheel. Where a bicycle incorporates features at the rear wheel other than the frame and mudguard stays, the moving reflector shall be mounted on the front wheel, or

- b) a continuous circle of reflective material applied to both sides of each wheel within 10 cm of the outer diameter of the tyre.

All side reflectors shall be of the same colour, either white (clear) or yellow.

4.20.4.3 Front reflectors

Front reflectors shall be white (clear) in colour.

4.20.4.4 Pedal reflectors

Each pedal shall have reflectors, located on the front and rear surfaces of the pedal. The reflector elements shall be either integral with the construction of the pedal or mechanically attached, but shall be recessed from the edge of the pedal, or of the reflector housing, to prevent contact of the reflector element with a flat edge placed in contact with the edge of the pedal.

Pedal reflectors shall be yellow in colour.

4.21 Warning device

Where a bell or other suitable device is fitted, it shall comply with the provisions in force in the country in which the product is marketed.

5 Manufacturer's instructions

These instructions can be provided in all types of format (paper, CD, website, etc.) according to national regulations and shall be written in the language of the country where the bicycle is to be marketed, or by visual tools, such as pictograms and illustrations, which shall feature prominently in the product safety information. When an electronic format is provided, a paper version shall be available upon request. The customer shall be made aware of this information either by the manufacturer or the retailer. Instructions for use shall contain the following information:

- a) the type of use for which the bicycle has been designed (i.e. the type of terrain for which it is suitable) with a warning about the hazards of incorrect use;
- b) preparation for riding: how to measure and adjust the saddle height to suit the rider with an explanation of the insertion-depth warning marks on the seat-post and handlebar-stem. Clear information on which lever operates the front brake, which lever operates the rear brake, the presence of any brake-power modulators with an explanation of their function and adjustment, and the correct method of using a back-pedal brake if fitted;
- c) indication of minimum saddle height and the way to measure it;
- d) the recommended method for adjusting any adjustable suspension system fitted;
- e) recommendations for safe riding, the use of a bicycle helmet, regular checks on brakes, tyre pressure, steering, rims, and caution concerning possible increased braking distances in wet weather;
- f) an advisory note on specific risk of entrapment during normal use and maintenance;
- g) the safe use and adjustment of foot-securing devices if fitted (i.e. quick-release pedals and toe clips);
- h) the permissible total weight of the rider plus luggage and the maximum total weight (bicycle + rider + luggage);
- i) indication of whether or not a bicycle is suitable for the fitting of a luggage carrier and/or a child seat;
- j) recommendation about usage for bicycle trailer or trailer bicycle if allowed by bicycle manufacturer;

- k) an advisory note to draw attention to the rider concerning possible national legal requirements when the bicycle is to be ridden on public roads (e.g. lighting and reflectors);
- l) recommended tightening of fasteners related to the handlebar, handlebar stem, saddle, seat-post, wheels, and aerodynamic extension if fitted with torque values for threaded fasteners;
- m) the method for determining the correct adjustment of quick-release devices, such as “the mechanism should emboss the fork-ends when closed to the locked position”;
- n) the correct method of assembling any parts supplied unassembled;
- o) lubrication: where and how often to lubricate and the recommended lubricants;
- p) the correct chain tension and how to adjust it (if appropriate);
- q) adjustments of gears and their operation (if appropriate);
- r) adjustment of brakes and recommendations for the replacement of the friction components;
- s) recommendations on general maintenance;
- t) the importance of using only genuine replacement parts for safety-critical components;
- u) care of the wheel rims and a clear explanation of any danger of rim wear (see also [4.11.5](#) and [6.2](#)). For composite rims where wear damage can be invisible to the user, the manufacturer shall explain the consequences of rim wear and how the cyclist can assess the degree of wear or should recommend returning the composite rim to the manufacturer for inspection;
- v) the correct gluing technique for wheels equipped with tubular tyres if fitted (see also [4.11.4](#));
- w) appropriate spares, i.e. tyres, tubes, and brake friction-components;
- x) accessories: where these are offered as fitted, details should be included such as operation, maintenance required (if any), and any relevant spares (e.g. light bulbs);
- y) an advisory note to draw the attention of the rider to possible damage due to intensive use and to recommend periodic inspections of the frame, fork, suspensions joints (if any), and composite components (if any). The wording of the advice can be as follows:

WARNING:

— As with all mechanical components, the bicycle is subjected to wear and high stresses. Different materials and components might react to wear or stress fatigue in different ways. If the design life of a component has been exceeded, it may suddenly fail, possibly causing injuries to the rider. Any form of crack, scratches, or change of colouring in highly stressed areas indicate that the life of the component has been reached and it should be replaced.

— For composite components, impact damage may be invisible to the user, the manufacturer shall explain the consequences of impact damage and that in the event of an impact; composite components should either be returned to the manufacturer for inspection or destroyed and replaced.

- z) for composite components, an advisory note to draw attention to the influence of high temperature (heat radiations) in confined environment on composite materials (if appropriate);
- aa) for city and trekking bicycles, the importance of suitably covering any coil springs under the saddle if a child-seat is fitted to prevent trapping of fingers;
- bb) for racing bicycles, caution concerning possible reduction of toe-clearance due to replacement of cranks or tyres;
- cc) for racing bicycles, an advisory note to draw attention to the fact that when using an aerodynamic extension on the handlebar, the rider’s response to steering and braking can be adversely affected;

dd) the maximum inflation pressure for a conventional or tubular tyre, according to the lower value between maximum inflation pressure recommended on the rim or the tyre (see also [4.11.2](#)).

Any other relevant information can be included at the discretion of the manufacturer.

6 Marking

6.1 Requirement

The frame shall be

- a) visibly and permanently marked with a successive frame number at a readily visible location such as near the pedal-crank, the seat-post, or the handlebar, and
- b) visibly and durably marked, with the name of the manufacturer of the complete bicycles or the manufacturer's representative and the number of this part of ISO 4210, i.e. ISO 4210-2. The method of testing for durability is specified in [6.2](#).

NOTE 1 It is recommended that the maximum permissible load (rider plus luggage) is marked at a readily visible location on the frame by the manufacturer.

NOTE 2 In some countries, there is a legal requirement concerning marking of bicycles.

NOTE 3 For components, currently there are no specific requirements, but it is recommended that the following safety-critical components be clearly and permanently marked with traceable identification, such as a manufacturer's name and a part number:

- a) front fork;
- b) handlebar and handlebar stem;
- c) seat-post;
- d) brake levers, brake blocks, and/or brake-block holders;
- e) outer brake-cable casing;
- f) hydraulic-brake tubing;
- g) disc-brake callipers, brake-discs, and brake pads;
- h) chain;
- i) pedals and cranks;
- j) bottom-bracket spindle;
- k) wheel rims.

6.2 Durability test

When tested by the method described in ISO 4210-3:2014, 4.4, the marking shall remain easily legible. It shall not be easily possible to remove any label, nor shall any label show any sign of curling.

Annex A (informative)

Steering geometry

The steering geometry employed, as shown in [Figure A.1](#), will generally be dictated by the use for which the bicycle is intended, but it is nevertheless recommended that

- a) the steering head angle be not more than 75° and not less than 65° in relation to the ground line, and
- b) the steering axis intersects a line perpendicular to the ground line, drawn through the wheel centre, at a point not lower than 15 % and not higher than 60 % of the wheel radius when measured from the ground line.

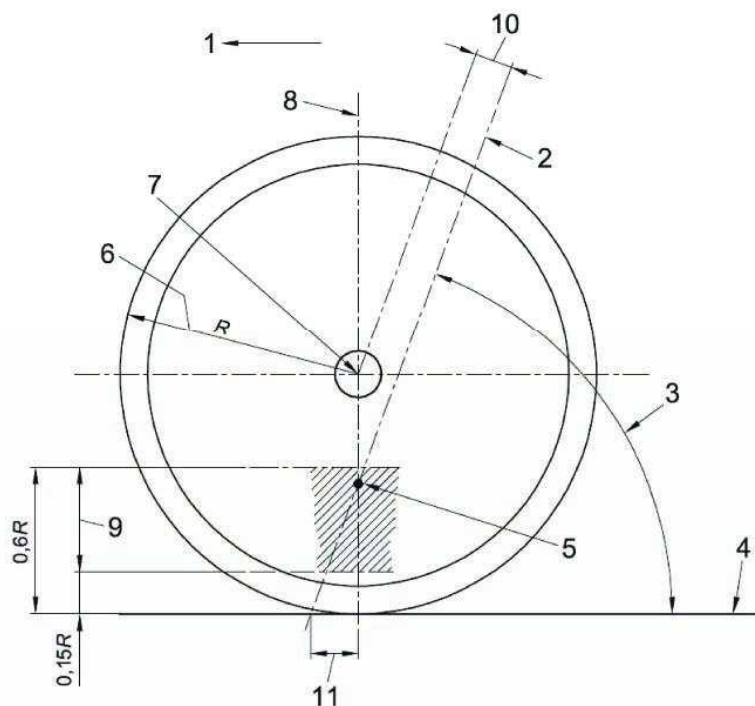

Key

- | | | | |
|---|---------------------|----|------------------------------|
| 1 | direction of travel | 7 | wheel centre |
| 2 | steering axis | 8 | perpendicular to ground line |
| 3 | steering head angle | 9 | tolerance |
| 4 | ground line | 10 | offset |
| 5 | intersection point | 11 | trail |
| 6 | wheel radius | | |

Figure A.1 — Steering geometry

Bibliography

- [1] ISO 8124-1, *Safety of toys — Part 1: Safety aspects related to mechanical and physical properties*
- [2] ISO 8098, *Cycles — Safety requirements for bicycles for young children*
- [3] ISO 13715:2000, *Technical drawings — Edges of undefined shape — Vocabulary and indications*
- [4] ISO 898-1, *Mechanical properties of fasteners made of carbon steel and alloy steel — Part 1: Bolts, screws and studs with specified property classes — Coarse thread and fine pitch thread*
- [5] ISO 3452-1, *Non-destructive testing — Penetrant testing — Part 1: General principles*
- [6] ISO 3452-2, *Non-destructive testing — Penetrant testing — Part 2: Testing of penetrant materials*
- [7] ISO 3452-3, *Non-destructive testing — Penetrant testing — Part 3: Reference test blocks*
- [8] ISO 3452-4, *Non-destructive testing — Penetrant testing — Part 4: Equipment*
- [9] ETRTO — *Standards manual (and successive editions)*, ETRTO, The European Tyre and Rim Technical Organisation, Avenue Brugmann 32/2, B-1060 Brussels, Belgium
- [10] ETRTO — *Recommendations (and successive editions)*, ETRTO, The European Tyre and Rim Technical Organisation, Avenue Brugmann 32/2, B-1060 Brussels, Belgium

