

INTERNATIONAL  
STANDARD

ISO  
4204

Second edition  
2016-10-15

---

---

## Countersinks, 90°, with Morse taper shanks and detachable pilots

*Outils à chanfreiner à 90°, à queue cône Morse et pilote amovible*



Reference number  
ISO 4204:2016(E)

© ISO 2016



**COPYRIGHT PROTECTED DOCUMENT**

© ISO 2016, Published in Switzerland

All rights reserved. Unless otherwise specified, no part of this publication may be reproduced or utilized otherwise in any form or by any means, electronic or mechanical, including photocopying, or posting on the internet or an intranet, without prior written permission. Permission can be requested from either ISO at the address below or ISO's member body in the country of the requester.

ISO copyright office  
Ch. de Blandonnet 8 • CP 401  
CH-1214 Vernier, Geneva, Switzerland  
Tel. +41 22 749 01 11  
Fax +41 22 749 09 47  
copyright@iso.org  
www.iso.org

# Contents

Page

Foreword .....	iv
<b>1 Scope .....</b>	<b>1</b>
<b>2 Normative references .....</b>	<b>1</b>
<b>3 Dimensions .....</b>	<b>1</b>
<b>4 Tolerances .....</b>	<b>1</b>
<b>Annex A (informative) Relationship between designations in this International Standard and ISO 13399 .....</b>	<b>3</b>
<b>Bibliography .....</b>	<b>4</b>

## Foreword

ISO (the International Organization for Standardization) is a worldwide federation of national standards bodies (ISO member bodies). The work of preparing International Standards is normally carried out through ISO technical committees. Each member body interested in a subject for which a technical committee has been established has the right to be represented on that committee. International organizations, governmental and non-governmental, in liaison with ISO, also take part in the work. ISO collaborates closely with the International Electrotechnical Commission (IEC) on all matters of electrotechnical standardization.

The procedures used to develop this document and those intended for its further maintenance are described in the ISO/IEC Directives, Part 1. In particular the different approval criteria needed for the different types of ISO documents should be noted. This document was drafted in accordance with the editorial rules of the ISO/IEC Directives, Part 2 (see [www.iso.org/directives](http://www.iso.org/directives)).

Attention is drawn to the possibility that some of the elements of this document may be the subject of patent rights. ISO shall not be held responsible for identifying any or all such patent rights. Details of any patent rights identified during the development of the document will be in the Introduction and/or on the ISO list of patent declarations received (see [www.iso.org/patents](http://www.iso.org/patents)).

Any trade name used in this document is information given for the convenience of users and does not constitute an endorsement.

For an explanation on the meaning of ISO specific terms and expressions related to conformity assessment, as well as information about ISO's adherence to the World Trade Organization (WTO) principles in the Technical Barriers to Trade (TBT) see the following URL: [www.iso.org/iso/foreword.html](http://www.iso.org/iso/foreword.html).

The committee responsible for this document is ISO/TC 29, *Small tools*, Subcommittee SC 2, *Holding tools, adaptive items and interfaces*.

This second edition cancels and replaces the first edition (ISO 4204:1977), of which it constitutes a minor revision, notably with the addition of [Annex A](#), which gives the relationship between the designations of this International Standard and the ISO 13399 series.

# Countersinks, 90°, with Morse taper shanks and detachable pilots

## 1 Scope

This International Standard specifies the dimensions of 90° countersinks with Morse taper shanks and detachable pilots for general use.

[Figure 1](#) is diagrammatic only and is not intended to indicate details of design.

## 2 Normative references

The following documents, in whole or in part, are normatively referenced in this document and are indispensable for its application. For dated references, only the edition cited applies. For undated references, the latest edition of the referenced document (including any amendments) applies.

ISO 296, *Machine tools — Self-holding tapers for tool shanks*

## 3 Dimensions

The dimensions for 90° countersinks with Morse taper shanks and detachable pilots are given in [Table 1](#). It specifies dimensions in metric units only, these being regarded as the only recommended dimensions in the future.

## 4 Tolerances

The tolerances relating to the countersink, Morse taper shanks and detachable pilots are as follows:

- cutting diameter  $d_1$ : z9;
- pilot diameter  $d_2$ : e8;
- pilot hole diameter  $d_3$ : H8;
- Morse taper: according to ISO 296.

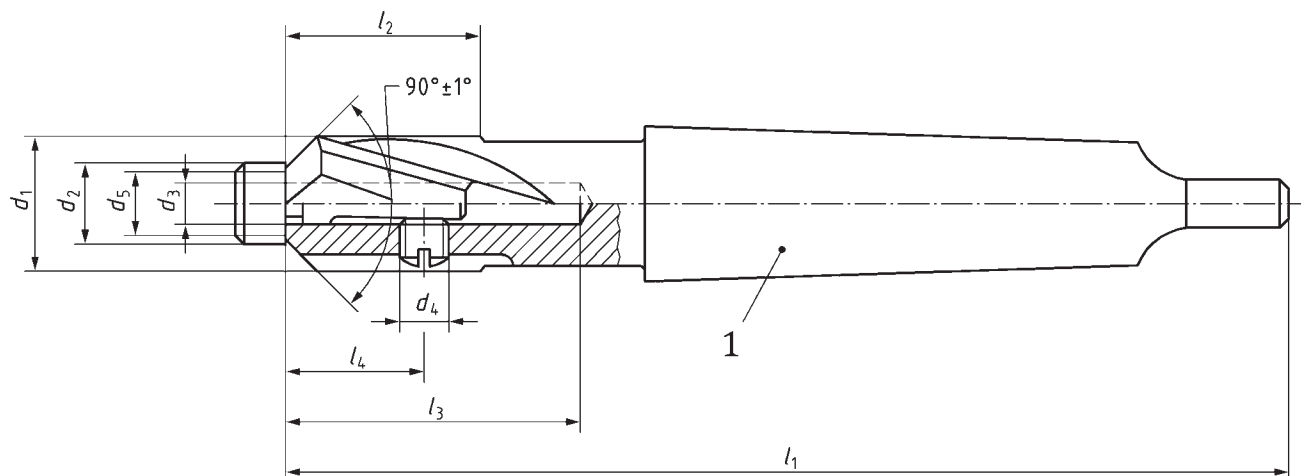

**Key**

1 Morse taper shank

**Figure 1**

**Table 1**

Dimensions in millimetres

Cutting diameter $d_1$ (z9)		Pilot diameter $d_2$ (e8)		$d_3$ (H8)	Set screw $d_4$	$d_5$	$l_1$	$l_2$	$l_3$	$l_4$	Morse taper shank N°
over	to	over	to								
12,5	16	6,3	14	4	M3	6	132	22	30	16	2
16	20	6,3	18	5	M4	6	140	25	38	19	
20	25	8	22,4	6	M5	7,5	150	30	46	23	
25	31,5	10	28	8	M6	9,5	180	35	54	27	3
31,5	40	12,5	35,5	10	M8	12	190	40	64	32	

## Annex A (informative)

### Relationship between designations in this International Standard and ISO 13399

For the relationship between the designations of this International Standard and preferred symbols according to ISO 13399, see [Table A.1](#).

**Table A.1 — Relationship between designations in this International Standard and ISO 13399**

Symbol in ISO 8051:1999	Reference in ISO 8051:1999	Property name in the ISO 13399 series	Symbol in the ISO 13399 series	Reference in the ISO 13399 series
$d_1$	Figure 1 Table 1	Cutting diameter	DC	71D084653E57F
$d_2$	Figure 1 Table 1	Guide pilot diameter	GPD	71ED6A7A6E6A2
$d_3$	Figure 1 Table 1	Connection diameter work- piece side	DCONWS	7272379A5F325
$d_5$	Figure 1 Table 1	Interference cutting diame- ter	DCINTF	726E2FCC0EC78
$l_1$	Figure 1 Table 1	Overall length	OAL	71D078EB7C086
$d_3$ <b>H8</b>	Table 1	Tolerance class connection diameter workpiece side	TCDCONWS	727ED91B5AA66
90°	Figure 1	Point angle	SIG	71DCCC4FEF366

## Bibliography

- [1] ISO 4207, *Counterbores with morse taper shanks and detachable pilots*
- [2] ISO 4208, *Detachables pilots for use with counterbores and 90 degrees countersinks — Dimensions*
- [3] ISO 8051:1999, *Long shank taps with nominal diameters from M3 to M10 — Full-diameter shank taps with recess*
- [4] ISO 13399 (all parts), *Cutting tool data representation and exchange*





