

INTERNATIONAL
STANDARD

ISO
4091

Third edition
2003-11-01

**Road vehicles — Connectors for the
electrical connection of towing and towed
vehicles — Definitions, tests and
requirements**

*Véhicules routiers — Connecteurs pour liaisons électriques entre
véhicules tracteurs et véhicules tractés — Définitions, essais et
exigences*



Reference number
ISO 4091:2003(E)

© ISO 2003

PDF disclaimer

This PDF file may contain embedded typefaces. In accordance with Adobe's licensing policy, this file may be printed or viewed but shall not be edited unless the typefaces which are embedded are licensed to and installed on the computer performing the editing. In downloading this file, parties accept therein the responsibility of not infringing Adobe's licensing policy. The ISO Central Secretariat accepts no liability in this area.

Adobe is a trademark of Adobe Systems Incorporated.

Details of the software products used to create this PDF file can be found in the General Info relative to the file; the PDF-creation parameters were optimized for printing. Every care has been taken to ensure that the file is suitable for use by ISO member bodies. In the unlikely event that a problem relating to it is found, please inform the Central Secretariat at the address given below.

© ISO 2003

All rights reserved. Unless otherwise specified, no part of this publication may be reproduced or utilized in any form or by any means, electronic or mechanical, including photocopying and microfilm, without permission in writing from either ISO at the address below or ISO's member body in the country of the requester.

ISO copyright office
Case postale 56 • CH-1211 Geneva 20
Tel. + 41 22 749 01 11
Fax + 41 22 749 09 47
E-mail copyright@iso.org
Web www.iso.org

Published in Switzerland

Contents

Page

Foreword.....	iv
1 Scope	1
2 Normative references	1
3 Terms and definitions	2
4 General requirements	3
4.1 Explanations	3
4.2 Test sequences	3
4.3 Sample requirement	4
5 Tests and requirements	4
5.1 Visual examination	4
5.2 Dimensional check	4
5.3 Connection and disconnection	5
5.4 Locking device operation	5
5.5 Ejector force	5
5.6 Locking device and cable retention strength	6
5.7 Lateral strength at low temperature	6
5.8 Current carrying capacity	7
5.9 Connection resistance (voltage drop)	8
5.10 Current cycling	9
5.11 Withstand voltage	9
5.12 Influence of water	10
5.13 Static load	12
5.14 Protection against dust	13
5.15 Endurance	13
5.16 Vibration	13
5.17 Drop	15
5.18 Temperature/humidity cycling	16
5.19 Salt spray	17
6 Additional required information — Material specification	18



Foreword

ISO (the International Organization for Standardization) is a worldwide federation of national standards bodies (ISO member bodies). The work of preparing International Standards is normally carried out through ISO technical committees. Each member body interested in a subject for which a technical committee has been established has the right to be represented on that committee. International organizations, governmental and non-governmental, in liaison with ISO, also take part in the work. ISO collaborates closely with the International Electrotechnical Commission (IEC) on all matters of electrotechnical standardization.

International Standards are drafted in accordance with the rules given in the ISO/IEC Directives, Part 2.

The main task of technical committees is to prepare International Standards. Draft International Standards adopted by the technical committees are circulated to the member bodies for voting. Publication as an International Standard requires approval by at least 75 % of the member bodies casting a vote.

Attention is drawn to the possibility that some of the elements of this document may be the subject of patent rights. ISO shall not be held responsible for identifying any or all such patent rights.

ISO 4091 was prepared by Technical Committee ISO/TC 22, *Road vehicles*, Subcommittee SC 3, *Electrical and electronic equipment*.

This third edition cancels and replaces the second edition (ISO 4091:1992), which has been technically revised.

Road vehicles — Connectors for the electrical connection of towing and towed vehicles — Definitions, tests and requirements

1 Scope

This International Standard gives definitions and specifies tests and requirements for connectors used for the electrical connection of towing and towed road vehicles. It is applicable to connectors of all types used for this purpose, as specified in ISO 1185, ISO 1724, ISO 3731, ISO 3732, ISO 7638-1, ISO 7638-2, ISO 11446 and ISO 12098.

NOTE Dimensions and particular requirements related to the design of the connector are given in separate International Standards.

2 Normative references

The following referenced documents are indispensable for application of this document. For dated references, only the edition cited applies. For undated references, the latest edition of the referenced document (including any amendments) applies.

ISO 1185, *Road vehicles — Connectors for the electrical connection of towing and towed vehicles — 7-pole connector type 24 N (normal) for vehicles with 24 V nominal supply voltage*

ISO 1724, *Road vehicles — Connectors for the electrical connection of towing and towed vehicles — 7-pole connector type 12 N (normal) for vehicles with 12 V nominal supply voltage*

ISO 1817, *Rubber, vulcanized — Determination of the effect of liquids*

ISO 3731, *Road vehicles — Connectors for the electrical connection of towing and towed vehicles — 7-pole connector type 24 S (supplementary) for vehicles with 24 V nominal supply voltage*

ISO 3732, *Road vehicles — Connectors for the electrical connection of towing and towed vehicles — 7-pole connector type 12 S (supplementary) for vehicles with 12 V nominal supply voltage*

ISO 7638-1, *Road vehicles — Connectors for the electrical connection of towing and towed vehicles — Part 1: Connectors for braking systems and running gear of vehicles with 24 V nominal supply voltage*

ISO 7638-2, *Road vehicles — Connectors for the electrical connection of towing and towed vehicles — Part 2: Connectors for braking systems and running gear of vehicles with 12 V nominal supply voltage*

ISO 9227, *Corrosion tests in artificial atmospheres — Salt spray tests*

ISO 11446¹⁾, *Road vehicles — Connectors for the electrical connection of towing and towed vehicles — 13-pole connectors for vehicles with 12 V nominal supply voltage*

1) To be published. (Revision of ISO 11446:1995)

ISO 12098²⁾, *Road vehicles — Connectors for the electrical connection of towing and towed vehicles — 15-pole connector for vehicles with 24 V nominal supply voltage*

IEC 60529, *Degrees of protection provided by enclosures (IP Code)*

3 Terms and definitions

For the purposes of this document, the following terms and definitions apply.

3.1 connection

two mated connectors or contacts

3.2 connector

assembly of contacts and housing which terminates conductors for the purpose of providing connection and disconnection to a suitable mating connector

3.3 contact

conductive element in a connector (including means for cable attachment) which mates with a corresponding element to provide an electrical path

3.4 contact area

area in contact between two mated contacts, which provides an electrical path

3.5 female contact

electrical contact (including means for cable attachment) intended to make electrical engagement on its inner surface and to accept entry of a male contact, thus forming an electrical connection

EXAMPLE Receptacle, sleeve.

3.6 male contact

electrical contact (including means for cable attachment) intended to make electrical engagement on its outer surface and to enter a female contact, thus forming an electrical connection

EXAMPLE Tab, pin, blade.

3.7 plug

free connector intended to mate with a socket

3.8 socket

connector intended to mate with a plug-in device

3.9 park socket

socket for storing the plug when it is disconnected

2) To be published. (Revision of ISO 12098:1994)

3.10 ejector

part of the socket (but not of the park socket) provided to disengage the plug automatically if the locking device is not operative

4 General requirements

4.1 Explanations

Tests and requirements are specified in the following clauses, with the generally applicable test sequences given in 4.2. Alternative tests, requirements and test sequences are as specified in the International Standards directly applicable to individual connection designs.

4.2 Test sequences

Where no test sequence is given in the International Standard that specifies the type of the connector under test, the test sequence followed shall be as given in Table 1.

Table 1 — Test sequences

Subclause	Test title	Sample group					
		A	B	C	D	E	F
5.1	Visual examination	1, 7, 9, 14	1, 12	1, 6, 12	1, 6	1, 14	1, 7
5.2	Dimensional check	2					
5.3	Connection	3	2	2		12	
5.3	Disconnection	12	11	10		13	
5.4	Locking device operation	4, 11	3, 10	3, 9		2, 10	
5.5	Ejector force	13				11	
5.6	Locking device and cable retention strength	6					
5.7	Lateral strength at low temperature	8					
5.8	Current carrying capacity				3		
5.9	Connection resistance		4, 7	4, 8	2, 5	3, 7	2, 5
5.10	Current cycling				4		
5.11	Withstand voltage		5, 9	7		4, 9	3, 6
5.12	Influence of water		8	11		8	
5.13	Static load	5					
5.14	Protection against dust					5	
5.15	Endurance					6	
5.16	Vibration						4
5.17	Drop	10					
5.18	Temperature/humidity cycling		6				
5.19	Salt spray			5			

ISO 4091:2003(E)

The test sequence shall be carried out in the order of the running numbers given in Table 1 under the particular sample group. A test sequence shall be continued only if the sample meets the applicable requirements.

All test sequences shall

- be preceded by conditioning of all samples of connectors, cables and test rods at $23\text{ °C} \pm 5\text{ °C}$ and 45 % to 75 % relative humidity for a minimum of 24 h,
- start with unused, dry and clean connectors, with plug and socket of the same manufacture and type, and
- be carried out at an ambient temperature of $23\text{ °C} \pm 5\text{ °C}$ unless otherwise specified.

During the entire test sequence, no lubrication or other additional aid to reaching better results is permitted. However, production-related remains of lubricants may be used.

4.3 Sample requirement

Cables shall be attached as appropriate.

If the connector is not equipped with the full complement of contacts, the remaining holes shall be covered.

5 Tests and requirements

5.1 Visual examination

5.1.1 Test

Carry out the visual examination with the naked eye, corrected, if necessary, to give normal strength of vision and normal colour perception, at the most favourable viewing distance and with suitable illumination.

5.1.2 Requirement

Visual examination in accordance with 5.1.1 shall allow identification, appearance, workmanship and finish of the item to be checked against the relevant specification.

During visual examination of the connector or connectors after tests involving the test sample groups (for test sequences, see Table 1), special care shall be taken to ensure that, as a minimum requirement, no cracking, significant discoloration, deformation, and — where applicable — no ingress of water is in evidence.

5.2 Dimensional check

5.2.1 Test

Check all the dimensions given in the International Standard that specifies the type of connector under test.

5.2.2 Requirement

All dimensions checked shall be within the tolerances given in the International Standard that specifies the type of the connector under test. Failure of any of these dimensions entails the failure of the sample.

5.3 Connection and disconnection

5.3.1 Test

Perform connection and disconnection using suitable test apparatus at a constant speed between 25 mm/min and 100 mm/min.

Disable the ejector, if the socket to be tested is equipped with one.

Measure the force required axially to the connector with the locking device disengaged and the cover not resting on the plug.

5.3.2 Requirement

The force measured according to 5.3.1 shall meet the requirements of the International Standard that specifies the type of connector under test.

5.4 Locking device operation

5.4.1 Application

The following applies to connectors equipped with a locking device.

5.4.2 Test

5.4.2.1 Locking lever operation

Measure the force required to operate the locking lever at the centre point of the locking device operational area and in the direction specified by the manufacturer.

5.4.2.2 Twist-lock operation

Measure the torque required to engage, disengage and lock the twist-lock.

5.4.3 Requirements

5.4.3.1 The force measured for operating the locking lever according to 5.4.2.1 shall not exceed 120 N.

5.4.3.2 The torque measured on the coupling ring of the twist lock according to 5.4.2.2 shall not exceed 3,5 N·m.

5.5 Ejector force

5.5.1 Application

The following applies to sockets equipped with a physical means of ejecting the plug when the locking device is not engaged.

5.5.2 Test

Measure the force of the ejector in the socket along its moving direction over the full travel range.

5.5.3 Requirement

The ejector tested according to 5.5.2 shall produce a force within the range of 35 N to 75 N, including any force variation over the ejector spring travel.

5.6 Locking device and cable retention strength

5.6.1 Test

Carry out the test using a mated plug and socket and a plug assembled with a 5 mm ± 0,5 mm diameter metal rod coated with cable-quality PVC to give an outside diameter of 12 mm ± 0,5 mm for the connectors. The exception to this requirement is the connector according to ISO 12098, for which a test rod of 15 mm ± 0,5 mm diameter shall be used, fixed as if it were a cable. Apply a force increasing linearly within 10 s from 0 N to 1 000 N to the test rod in the withdrawal direction. Maintain the value of 1 000 N $^{+10}_0$ N for 10 s $^{+2}_0$ s.

5.6.2 Requirement

No cracks or permanent deformation shall be visible after the test according to 5.6.1.

The test rod shall not have moved more than 2 mm after this test, measured on the PVC surface.

Connectors tested according to 5.6.1 shall fulfil subsequently performed tests in accordance with Table 1 or the International Standard that specifies the type of the connector under test.

5.7 Lateral strength at low temperature

5.7.1 Test

Carry out the lateral strength test in a test chamber at -40 °C ± 2 °C, socket- and plug-mated and mounted as designed. Assemble the plug with a test rod in accordance with 5.6.1. Ensure that the test sample has reached -40 °C ± 2 °C. Apply a test torque of 25 N·m in four directions perpendicular to each other (see Figure 1), for 1 min in each direction, starting parallel to the socket cover hinge.

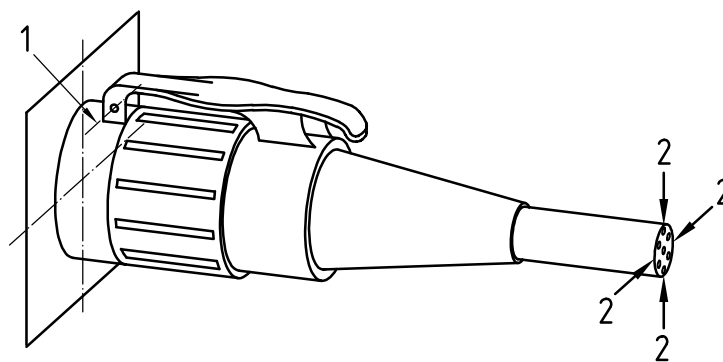

- Key**
- 1 socket cover hinge
 - 2 force (for torque)

Figure 1 — Application of torque

5.7.2 Requirement

No cracks or permanent deformation shall be visible after the test according to 5.7.1.

Connectors tested according to 5.7.1 shall fulfil subsequently performed tests in accordance with Table 1 or the International Standard that specifies the type of the connector under test.

5.8 Current carrying capacity

5.8.1 Test

Carry out the test, successively, on one contact pair (pin and tube) in the housings of mated connectors for each nominal cable cross-sectional area that the cable attachment of the contacts tested allows. The remaining contact cavities in the housings shall be left free.

Connect insulated test cables of $500 \text{ mm} \pm 5 \text{ mm}$ length and a cross-sectional area in accordance with Table 2 to the male and female contacts to be tested.

Apply a test current in accordance with Table 2 for 1 h and monitor the contact temperatures, measured at the contacts as shown in Figure 2.

Table 2 — Current carrying capacity test values

Nominal cross-sectional area of cable admissible at contact mm ²	Test cable nominal cross-sectional area mm ²	Test current A
6	6	30
2 × 2,5	6	30
4	4	25
2,5	2,5	20
2 × 1,5	2,5	20
1,5	1,5	15

5.8.2 Requirements

The temperature rise of each contact, tested in accordance with 5.8.1, shall not exceed 40 °C, where the temperature rise equals the measured contact temperature minus the test ambient temperature.

This current carrying capacity shall not be used as guide to the capability of the connection to operate at elevated ambient temperatures.

Connectors tested according to 5.8.1 shall fulfil subsequently performed tests in accordance with Table 1 or the International Standard that specifies the type of the connector under test.

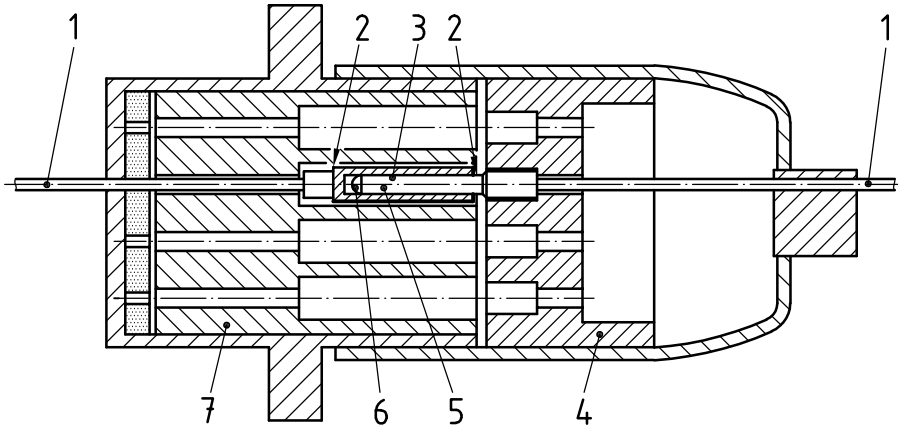

Key

- 1 cable
- 2 point of temperature measurement
- 3 contact area
- 4 plug
- 5 male contact
- 6 female contact
- 7 socket

Figure 2 — Temperature rise measurement at contacts

5.9 Connection resistance (voltage drop)

5.9.1 Test

5.9.1.1 Application and resistance measurement

Apply the test at millivolt level for data contacts and at specified current for all other contacts.

Measure the connection resistance using a test arrangement as shown in Figure 3. The resistances of the conductors between the conductor attachments and measuring points shall be subtracted from the measured value. The measuring points shall be as close as possible to the contacts without touching them.

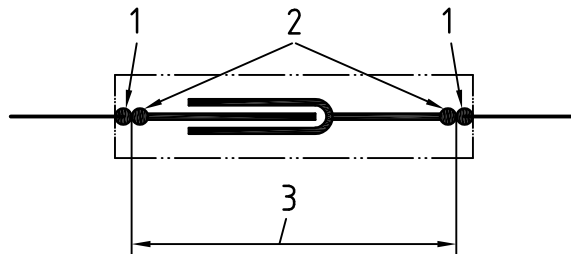

Key

- 1 measuring point
- 2 conductor attachment
- 3 connection resistance

Figure 3 — Connection resistance measurement

5.9.1.2 Measurements at millivolt level

Apply a test voltage not exceeding 20 mV d.c. or peak voltage a.c. in open circuit, to prevent the breakdown of possible insulating films of the contacts. The flow of current applied shall not exceed 100 mA.

5.9.1.3 Measurements at specified current

Take measurements after thermal equilibrium is reached at a current of 10 A d.c. The measuring points at the conductors may be outside the connector. Ensure that parts of the cable where the insulation is removed do not influence the test results.

If the measuring cables are soldered at the measuring points, they shall not influence the connections.

5.9.2 Requirements

The connection resistance of each individual connection (mated pair of contacts), measured in accordance with 5.9.1, shall not exceed 4 mV/A.

Connectors tested according to 5.9.1 shall fulfil subsequently performed tests in accordance with Table 1 or the International Standard that specifies the type of the connector under test.

5.10 Current cycling

5.10.1 Test

Carry out the current cycling test separately for one mated pair of each size of contacts of assembled connectors by applying 500 cycles. Each cycle shall be of 45 min with the test current in accordance with Table 2 and 15 min current off.

Attach cables of 500 mm \pm 5 mm length and having the appropriate cross-sectional area in accordance with Table 2 to the contacts under test.

5.10.2 Requirement

Connectors tested according to 5.10.1 shall fulfil subsequently performed tests in accordance with Table 1 or the International Standard that specifies the type of connector under test.

5.11 Withstand voltage

5.11.1 Test

Apply an a.c. voltage of 1000 V r.m.s. (50 Hz or 60 Hz) or a d.c. voltage of 1600 V for 1 min between all contacts of mated and unmated connectors connected together and the housing (when metallic) or a metal foil surrounding the housing. The housing or metal foil shall be connected to earth for safety reasons. The voltage shall also be applied, with a different sample, to every two adjacent contacts for 1 min.

5.11.2 Requirement

Neither a dielectric breakdown nor a flashover shall occur during the test according to 5.11.1.

Connectors tested according to 5.11.1 shall fulfil subsequently performed tests in accordance with Table 1 or the International Standard that specifies the type of the connector under test.

5.12 Influence of water

5.12.1 Splash water

5.12.1.1 Test

Carry out the test with

- a) plug and socket mated and locked,
- b) plug and park socket mated and locked (if a park socket is standardized),
- c) socket with cover closed, and
- d) park socket with cover closed.

Use the test apparatus shown in Figure 4.

The oscillating tube shall have holes of 0,8 mm diameter drilled at regular intervals over approximately 150°. The tube shall oscillate through an angle of almost 360°, 180° to either side of the vertical. The oscillating speed shall be approximately 90 °/s.

The water pressure shall be approximately 4 bar (= 0,4 MPa).

In each case, mount the test specimen horizontally with the cable or cables mounted and sealed as designed. Place the specimen in the test apparatus at the centre of the oscillating tube. The support shall be perforated so as to avoid acting as a baffle.

Subject each samples to the water splash test for (10 ± 1) min.

Dimensions in millimetres

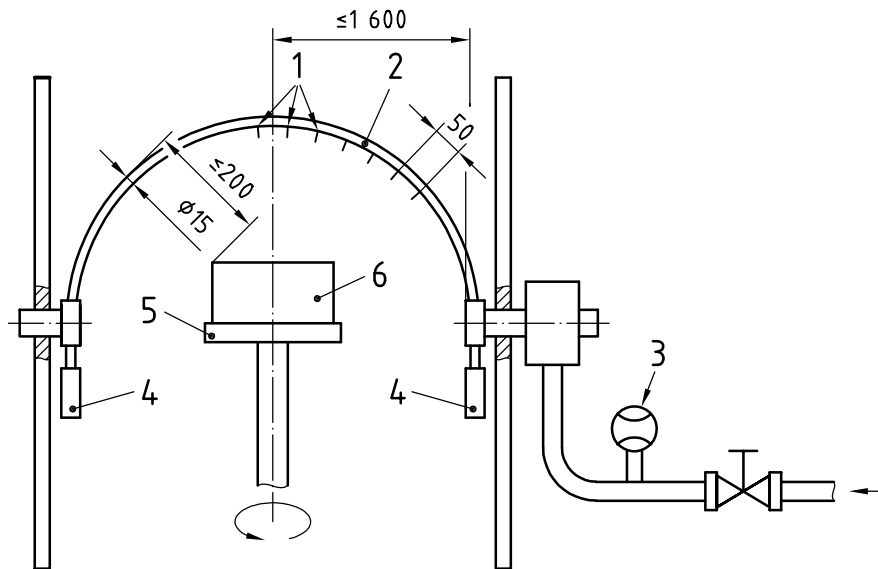

- Key**
- 1 holes \varnothing 0,8
 - 2 oscillating tube
 - 3 flow meter
 - 4 counterweights
 - 5 perforated support
 - 6 specimen

Figure 4 — Test apparatus for splash water test

5.12.1.2 Requirement

Connectors tested according to 5.12.1.1 shall fulfil subsequently performed tests in accordance with Table 1 or the International Standard that specifies the type of the connector under test.

5.12.2 High-pressure water jet

5.12.2.1 Test

Carry out the connector test with

- a) plug and socket mated and locked,
- b) plug and park socket mated and locked (if a park socket is standardized),
- c) socket with closed cover, and
- d) park socket with closed cover.

The test equipment and arrangement shall be in accordance with Figures 4 and 5.

The water flowing through the nozzle shall have

- a temperature of $(80 \pm 5) \text{ }^\circ\text{C}$,
- a flow rate between of 14 l/min and 16 l/min;
- a pressure of approximately 8 000 kPa to 10 000 kPa (measured as near as possible to the nozzle aperture).

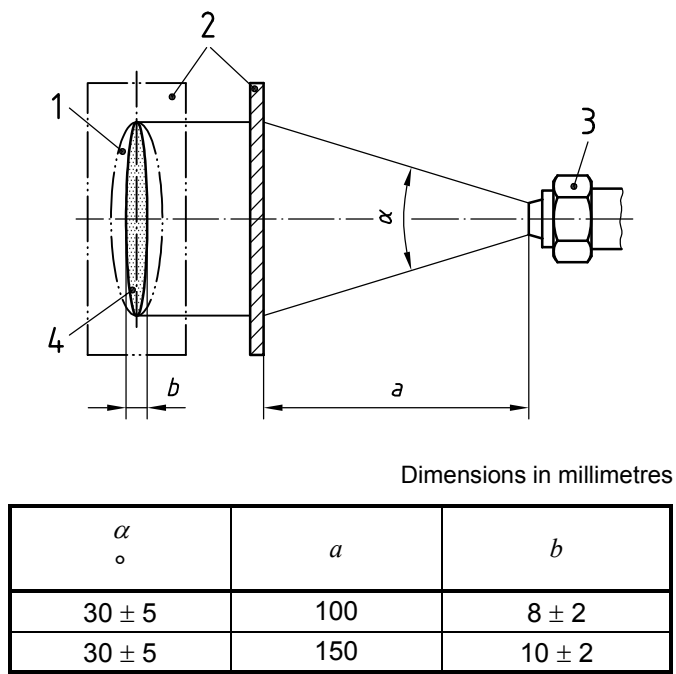

Key

- 1 scatter area
- 2 measuring area
- 3 nozzle
- 4 jet core

Figure 5 — Nozzle and jet dimensions (dispersion of water jet)

Mount the test sample on the support and rotate it at (5 ± 1) r/min, subjecting it to the high-pressure water jet for 30 s in each of the positions 1 to 4 as shown in Figure 6.

The distance between the nozzle aperture and its positions related to the sample shall be (125 ± 25) mm (see Figure 6).

After the test, open the covers of the socket with closed cover and the park socket with closed cover and allow to drain.

5.12.2.2 Requirements

Connectors tested according to 5.12.2.1 shall fulfil subsequently performed tests in accordance with Table 1 or the International Standard that specifies the type of the connector under test.

Dimensions in millimetres

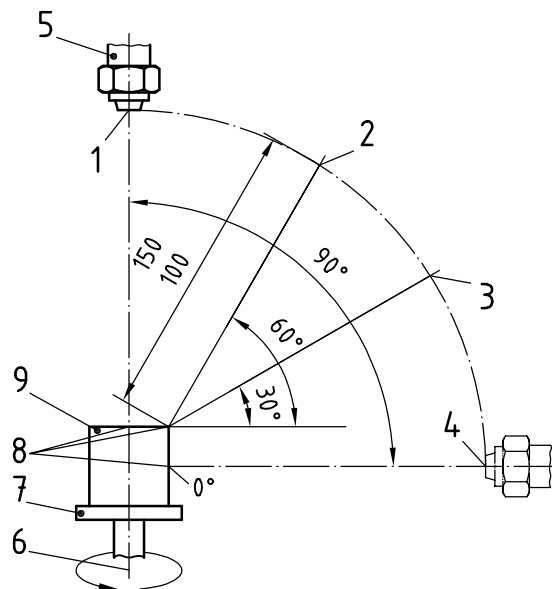

Key

- 1 Position 1
- 2 Position 2
- 3 Position 3
- 4 Position 4
- 5 nozzle
- 6 rotating axis
- 7 support
- 8 reference points (0°, 30°, 60° and 90°)
- 9 test sample

Figure 6 — Test arrangement

5.13 Static load

5.13.1 Test

Place the plug between two horizontal flat metal plates which overlap the specimen. Apply a static force of (500 ± 10) N to the plates.

Carry out this test using the same sample in every one of the positions in which it will rest naturally on the lower test plate.

5.13.2 Requirements

Connectors tested according to 5.13.1 shall fulfil subsequently performed tests in accordance with Table 1 or the International Standard that specifies the type of the connector under test.

5.14 Protection against dust

5.14.1 Test

Both the socket with the cover closed, and the plug and socket mated and assembled, as specified by the manufacturer, shall meet the degree of protection against dust of IP 5X according to IEC 60529.

5.14.2 Requirement

After the test according to 5.14.1, connection and disconnection shall not be affected by dust. Connectors tested according to in 5.14.1 shall fulfil subsequently performed tests in accordance with Table 1 or the International Standard that specifies the type of the connector under test.

5.15 Endurance

5.15.1 Test

Carry out the test with plug and socket equipped with the necessary contacts but without the cable.

The test consists of 5 000 mechanical cycles without electrical load. The number of cycles may be enlarged in accordance with the International Standard that specifies the type of the connector under test. One cycle consists of the following operations:

- a) opening of the cover;
- b) insertion of the plug into the socket;
- c) latching and unlatching the locking device;
- d) withdrawal of the plug;
- e) closing of the socket cover.

Insert and withdraw the plug at a velocity of (500 ± 100) mm/min. Carry out 4 cycles/min.

5.15.2 Requirement

Connectors tested according to 5.15.1 shall fulfil subsequently performed tests in accordance with Table 1 or the International Standard that specifies the type of the connector under test.

5.16 Vibration

5.16.1 Test

This test is used to check the electrical continuity of mated connections and the cover closing spring of the unmated sockets.

Apply a cable as used for normal operation to the plug. Support the cable only at 1 m from the socket front, independently from the vibration test bench, as shown in Figure 7, for example. For coiled cables, the cable length between the plug and the support shall be 4,5 m. Wire all contacts except the data contacts in series and connect them to a d.c. source adjusted to an initial current of 100 mA to monitor the connection resistance during the entire test (see the arrangement in Figure 8).

Wire the contacts for data transmission in series and connect them to a d.c. source adjusted to an initial current of 5 mA to monitor the connection resistance during the entire test (see the arrangement in Figure 8).

Subject the assembled and mounted connection to sinusoidal vibrations of

- 5 Hz to 11 Hz at ± 10 mm constant amplitude, and
- > 11 Hz to 200 Hz at 50 m/s^2 acceleration.

The frequency variation shall be 1 octave/min.

Apply the motion for 16 h in each of the three mutually perpendicular directions, i.e. vibrate the connection first axially, followed by vibration laterally, and then vertically. The total test time is thus 3×16 h for a total of 48 h.

Dimensions in metres

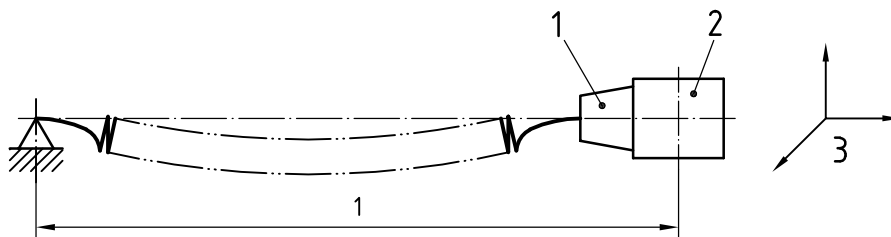

Key

- 1 plug
- 2 socket
- 3 vibration directions

Figure 7 — Vibration test

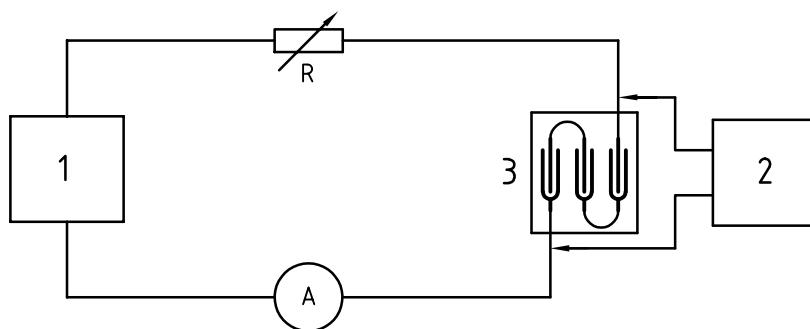

Key

- 1 power supply
- 2 connector under test
- 3 monitoring unit

Figure 8 — Connection resistance monitoring at vibration test

5.16.2 Requirements

5.16.2.1 Mated connection

During the vibration test according to 5.16.1, the connection resistance monitored shall not exceed $7\ \Omega$ for a period of more than $1\ \mu\text{s}$ (see Figure 9).

Dimensions in millimetres

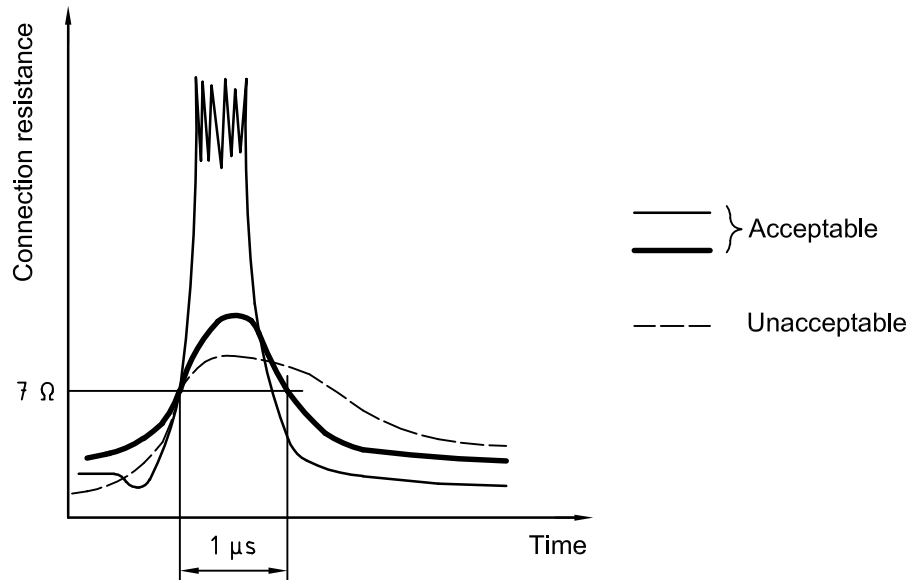

Figure 9 — Connection resistance during vibration

5.16.2.2 Socket and park socket alone

The socket and the park socket cover closing springs shall retain the cover closed when subjected to the vibration test as in 5.16.1.

5.17 Drop

5.17.1 Test

Wire the sample (unmated connector) according to its application. The length of the cable or cables and the test arrangement shall be in accordance with Figure 10. Attach the cable or cables to a fixed point and allow a free swinging of the test sample. A simple attachment on a hook is allowed.

Hold the sample horizontally and let it swing down to hit the steel plate of a size of $300\ \text{mm} \times 500\ \text{mm} \times 25\ \text{mm}$ (thickness). Repeat this as often as agreed between manufacturer and user.

5.17.2 Requirements

Connectors tested according to 5.17.1 shall fulfil subsequently performed tests in accordance with Table 1 or in the International Standard specifying the type of the connector under test.

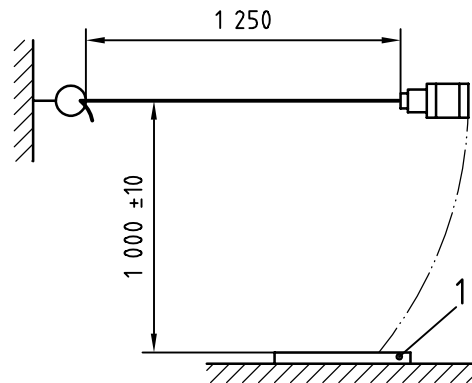
**Key**

1 steel plate

Figure 10 — Drop test arrangement**5.18 Temperature/humidity cycling****5.18.1 Test**

Carry out the temperature/humidity cycling test with a mated connection. Subject the sample in a suitable test chamber to five cycles of 24 h, each as follows and within the limits shown in Figure 11.

- a) Hold the chamber temperature at $t_c = (23 \pm 5) ^\circ\text{C}$ and at 45 % to 75 % RH (relative humidity) for 4 h.
- b) Raise t_c to $(55 \pm 2) ^\circ\text{C}$ at 95 % to 99 % RH within 0,5 h.
- c) Hold t_c at $(55 \pm 2) ^\circ\text{C}$ at 95 to 99 % for 10 h.
- d) Lower t_c to $(-40 \pm 2) ^\circ\text{C}$ within 2,5 h.
- e) Hold t_c at $(-40 \pm 2) ^\circ\text{C}$ for 2 h.
- f) Raise t_c to $(100 \pm 2) ^\circ\text{C}$ within 1,5 h.
- g) Hold t_c at $(100 \pm 2) ^\circ\text{C}$ for 2 h.
- h) Allow sample to return to room temperature $(23 \pm 5) ^\circ\text{C}$ within 1,5 h.

If the chamber needs more than 1,5 h to reach $(100 \pm 2) ^\circ\text{C}$, the duration of period f) may be extended. In this case, period a) shall be reduced accordingly.

At the end of a cycle, the test may be interrupted. During the interruption, test samples shall remain at the ambient conditions as defined in a). Interruption time shall be noted in the test report.

During periods d), e), f), g) and h), the relative humidity is uncontrolled.

See Figure 11 for a graphic representation of the test cycles.

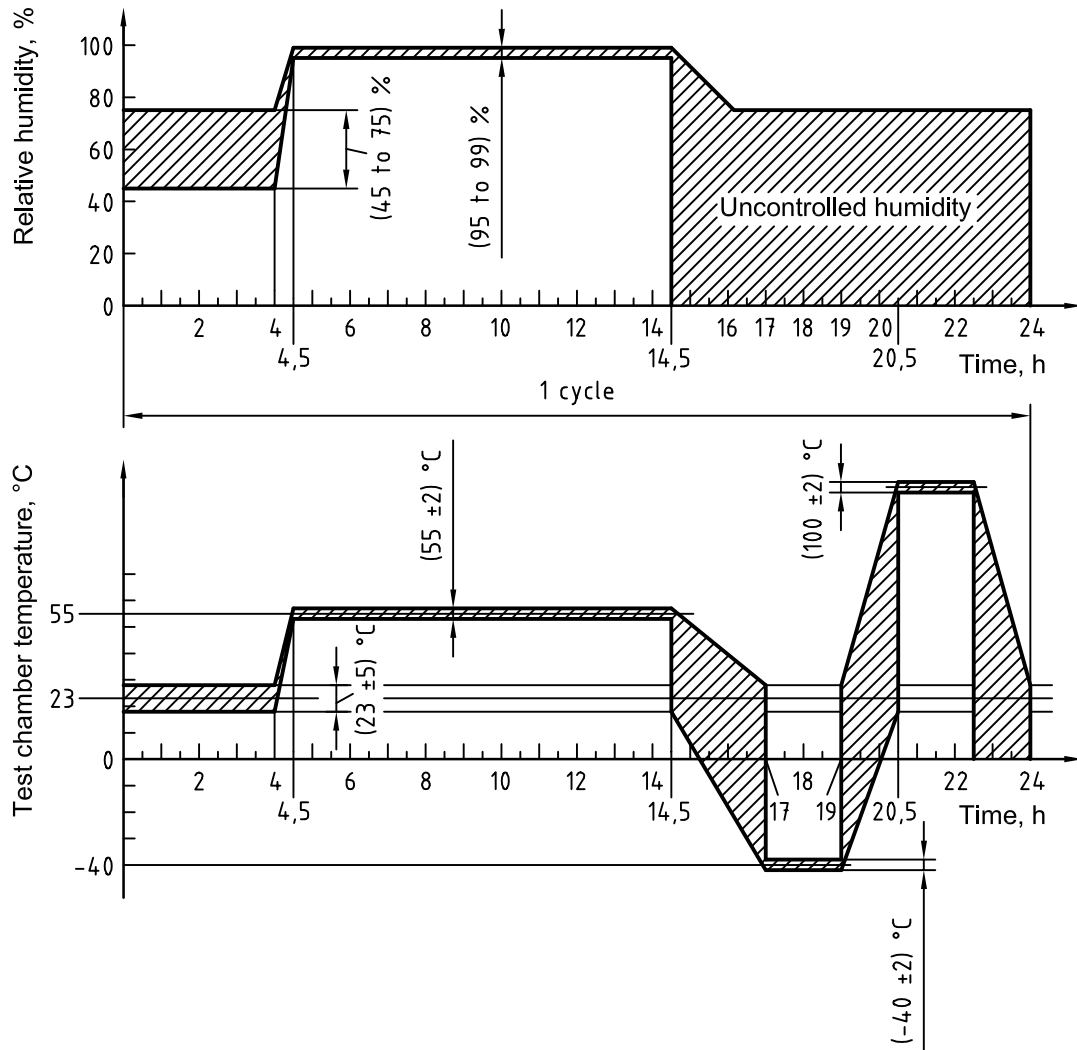

Figure 11 — Temperature/humidity cycling test

5.18.2 Requirement

Connectors tested according to 5.18.1 shall fulfil subsequently performed tests in accordance with Table 1 or the International Standard that specifies the type of the connector under test.

5.19 Salt spray

5.19.1 Test

Carry out the neutral salt spray (NSS) test according to ISO 9227 over 96 h. Test the connections in the combinations specified in 5.12.1.1 a) and 5.12.1.1 b) and the socket as specified in 5.12.1.1 c) and 5.12.1.1 d). Fit the connector with the full complement of contacts with cables connected as applicable. Mount the test sample horizontally with the cable or cables assembled and sealed as designed.

5.19.2 Requirement

At visual examination (see 5.1) no marks of corrosion shall be visible after the test according to 5.19.1.

Connectors tested according to 5.19.1 shall fulfil subsequently performed tests in accordance with Table 1 or the International Standard that specifies the type of the connector under test.

6 Additional required information — Material specification

The test report shall provide detailed information on the material used.

Verify the material specifications by checking the guaranteed material features of the material manufacturer, in particular in relation to the following:

- base (5 % KOH, 25 % K_2CO_3 , 70 % H_2O);
- test fuel (in accordance with ISO 1817);
- lubricating oil No. 1 (in accordance with ISO 1817);
- compression-ignition engine fuel;
- lubricating grease (in accordance with ISO 1817);
- solar radiation (under study).

.....

ICS 43.040.10

Price based on 18 pages