**Rubber hoses and tubing for cooling
systems for internal-combustion
engines — Specification**

*Tubes et tuyaux en caoutchouc pour systèmes de refroidissement pour
moteurs à combustion interne — Spécifications*



COPYRIGHT PROTECTED DOCUMENT

© ISO 2016, Published in Switzerland

All rights reserved. Unless otherwise specified, no part of this publication may be reproduced or utilized otherwise in any form or by any means, electronic or mechanical, including photocopying, or posting on the internet or an intranet, without prior written permission. Permission can be requested from either ISO at the address below or ISO's member body in the country of the requester.

ISO copyright office
Ch. de Blandonnet 8 • CP 401
CH-1214 Vernier, Geneva, Switzerland
Tel. +41 22 749 01 11
Fax +41 22 749 09 47
copyright@iso.org
www.iso.org

Contents

Page

Foreword	iv
1 Scope	1
2 Normative references	1
3 Classification	2
4 Size and tolerances	2
5 Performance requirements for hose and tubing	2
6 Frequency of testing	5
7 Marking	6
Annex A (normative) Dilation test	7
Annex B (normative) Resistance to surface contamination by engine oil	8
Annex C (normative) Pressure, vibration and temperature test	9
Annex D (informative) Example of how a non-standard type of hose or tubing could be specified by an original equipment manufacturer (OEM) using a matrix	11
Annex E (normative) Type test	12
Annex F (normative) Routine test	13
Annex G (informative) Production acceptance test	14
Bibliography	15

Foreword

ISO (the International Organization for Standardization) is a worldwide federation of national standards bodies (ISO member bodies). The work of preparing International Standards is normally carried out through ISO technical committees. Each member body interested in a subject for which a technical committee has been established has the right to be represented on that committee. International organizations, governmental and non-governmental, in liaison with ISO, also take part in the work. ISO collaborates closely with the International Electrotechnical Commission (IEC) on all matters of electrotechnical standardization.

The procedures used to develop this document and those intended for its further maintenance are described in the ISO/IEC Directives, Part 1. In particular the different approval criteria needed for the different types of ISO documents should be noted. This document was drafted in accordance with the editorial rules of the ISO/IEC Directives, Part 2 (see www.iso.org/directives).

Attention is drawn to the possibility that some of the elements of this document may be the subject of patent rights. ISO shall not be held responsible for identifying any or all such patent rights. Details of any patent rights identified during the development of the document will be in the Introduction and/or on the ISO list of patent declarations received (see www.iso.org/patents).

Any trade name used in this document is information given for the convenience of users and does not constitute an endorsement.

For an explanation on the meaning of ISO specific terms and expressions related to conformity assessment, as well as information about ISO's adherence to the World Trade Organization (WTO) principles in the Technical Barriers to Trade (TBT) see the following URL: www.iso.org/iso/foreword.html.

The committee responsible for this document is ISO/TC 45, *Rubber and rubber products*, Subcommittee SC 1, *Rubber and plastics hoses and hose assemblies*.

This fourth edition cancels and replaces the third edition (ISO 4081:2010), of which it constitutes a minor revision. The following change has been made:

- [Clause 2](#) has been updated, where ISO 1746 and ISO 4672 have been deleted and replaced by ISO 10619-1 and ISO 10619-2, respectively.

Rubber hoses and tubing for cooling systems for internal-combustion engines — Specification

WARNING — Persons using this International Standard should be familiar with normal laboratory practice. This International Standard does not purport to address all of the safety problems, if any, associated with its use. It is the responsibility of the user to establish appropriate safety and health practices and to ensure compliance with any national regulatory conditions.

1 Scope

This International Standard specifies the requirements for straight or pre-formed rubber hoses and tubing for use in pressurized or unpressurized cooling circuits containing 1,2-ethanediol-based coolants in internal-combustion engines for vehicles with an unladen mass (as defined in ISO 1176) of 3,5 t or less. In addition, this specification may also be applied as a classification system to enable original equipment manufacturers (OEMs) to detail a “line call-out” of tests for specific applications where these are not covered by the main types specified (see example in [Annex D](#)). In this case, the hose or tubing would not carry any marking showing this ISO specification number but may detail the OEM’s own identification markings as shown on their part drawings.

2 Normative references

The following documents, in whole or in part, are normatively referenced in this document and are indispensable for its application. For dated references, only the edition cited applies. For undated references, the latest edition of the referenced document (including any amendments) applies.

ISO 188, *Rubber, vulcanized or thermoplastic — Accelerated ageing and heat resistance tests*

ISO 1307, *Rubber and plastics hoses — Hose sizes, minimum and maximum inside diameters, and tolerances on cut-to-length hoses*

ISO 1402, *Rubber and plastics hoses and hose assemblies — Hydrostatic testing*

ISO 1629, *Rubber and latices — Nomenclature*

ISO 1817, *Rubber, vulcanized or thermoplastic — Determination of the effect of liquids*

ISO 6162-1, *Hydraulic fluid power — Flange connections with split or one-piece flange clamps and metric or inch screws — Part 1: Flange connectors, ports and mounting surfaces for use at pressures of 3,5 MPa (35 bar) to 35 MPa (350 bar), DN 13 to DN 127*

ISO 7233, *Rubber and plastics hoses and hose assemblies — Determination of resistance to vacuum*

ISO 7326:2016, *Rubber and plastics hoses — Assessment of ozone resistance under static conditions*

ISO 8033, *Rubber and plastics hoses — Determination of adhesion between components*

ISO 10619-1:2011, *Rubber and plastics hoses and tubing — Measurement of flexibility and stiffness — Part 1: Bending tests at ambient temperature*

ISO 10619-2:2011, *Rubber and plastics hoses and tubing — Measurement of flexibility and stiffness — Part 2: Bending tests at sub-ambient temperatures*

ISO 23529, *Rubber — General procedures for preparing and conditioning test pieces for physical test methods*

SAE J20:2006, *Coolant system hoses*

SAE J1638, *Compression set of hoses or solid discs*

SAE J1684:2005, *Test method for evaluating the electrochemical resistance of coolant system hoses and materials*

3 Classification

The product shall consist of rubber materials with or without an integral reinforcement which may or may not be pre-formed before final vulcanization. The hoses and tubing may be branched, in which case the method of attachment of the branch shall be such that the integrity of the hose is maintained when it is tested to this International Standard. This International Standard does not cover methods of attachment to mounting spigots.

Four types of hose and tubing for specific applications are specified as follows:

- Type 1 = Tubing and hoses for ambient operating temperatures from -40 °C to $+100\text{ °C}$;
- Type 2 = Tubing and hoses for ambient operating temperatures from -40 °C to $+125\text{ °C}$;
- Type 3 = Tubing and hoses for ambient operating temperatures from -40 °C to $+150\text{ °C}$;
- Type 4 = Tubing and hoses for ambient operating temperatures from -40 °C to $+175\text{ °C}$.

Wherever economically and technically possible, hoses and tubing shall use in their construction materials that are capable of being recycled. Also, wherever economically and technically possible, hoses and tubing shall use in their construction materials that contain post-consumer or post-industrial recyclates.

4 Size and tolerances

Bore sizes and tolerances shall be in accordance with ISO 1307. Wall thicknesses shall be sufficient to meet the requirements of this International Standard.

5 Performance requirements for hose and tubing

Tests shall be selected from the following list for each application of hose or tubing, based on the performance requirements of the finished product. Type tests (as defined in [Clause 6](#)) for each hose or tubing type are given in [Annex E](#).

a) Burst pressure

When determined in accordance with ISO 1402 at standard laboratory temperature as specified in ISO 23529, the minimum burst pressure shall be:

Tubing:	0,2 MPa (2 bar) for all diameters
Hose:	1,2 MPa (12 bar) for diameters up to and including 18 mm
	0,9 MPa (9 bar) for diameters >18 mm up to, and including, 35 mm
	0,5 MPa (5 bar) for diameters >35 mm

b) Adhesion (for all constructions with two or more bonded layers only)

When determined by the appropriate procedure of ISO 8033, the adhesion between each pair of bonded layers shall not be less than 1,8 kN/m for unaged hoses and not less than 1,3 kN/m for

hoses aged as specified in test i), immersed in oil as specified in test k) and fatigued by vibration as specified in test l).

c) Low-temperature flexibility

- For hoses and tubing of 25 mm inside diameter and below, with a minimum free straight-length section of 300 mm

When cooled to $-40\text{ °C} \pm 2\text{ °C}$ for $5\text{ h} \pm 0,5\text{ h}$ and tested in accordance with method B of ISO 10619-2:2011, the hose or tubing shall not exhibit any cracking when examined under $2\times$ magnification after bending within 4 s around a similarly cooled mandrel, the radius of which is $10\times$ the maximum outside diameter of the hose or tubing. The hose or tubing shall then conform to the burst strength requirement of test a).

- For hoses and tubing of >25 mm inside diameter, with a minimum free straight-length section of 300 mm

When tested in accordance with SAE J20:2006, 5.1.2, hose or tubing shall not exhibit any cracking when examined under $2\times$ magnification. The hose or tubing shall then conform to the burst strength requirement of test a).

d) Resistance to collapse

- For hoses <16 mm inside diameter

When the hose or tubing is tested in accordance with ISO 7233 at 0,015 MPa (0,15 bar) absolute at 100 °C for 10 min, the outside diameter shall not collapse by more than 30 %.

- For hoses >16 mm but <25 mm inside diameter

When the hose or tubing is tested in accordance with ISO 7233 at 0,02 MPa (0,2 bar) absolute at 100 °C for 10 min, the outside diameter shall not collapse by more than 30 %.

- For hoses >25 mm inside diameter

When the hose or tubing is tested in accordance with ISO 7233 at 0,03 MPa (0,3 bar) absolute at 100 °C for 10 min, the outside diameter shall not collapse by more than 30 %.

The change in outside diameter, ΔD , is given by [Formula \(1\)](#):

$$\Delta D = \frac{D_2 - D_1}{D_1} \times 100 \quad (1)$$

where

ΔD is the change in outside diameter (%);

D_1 is the outside diameter at the initial pressure (mm);

D_2 is the outside diameter at the specified pressure (mm).

e) Resistance to kinking (for straight hoses or tubing with bore sizes of 19,5 mm or less only)

When determined in accordance with method B of ISO 10619-1:2011, the maximum coefficient of deformation (T/D) shall exceed 0,7. The mandrel sizes to be used are 140 mm for hoses and tubing with bore sizes of 10,5 mm or less, 220 mm for hoses and tubing with bore sizes over 10,5 mm up to 16,5 mm, and 300 mm for hoses and tubing with bore sizes over 16,5 mm up to 19,5 mm.

f) **Resistance to dilation** (for hoses only)

When determined in accordance with [Annex A](#), the dilation shall not exceed 12 %.

The dilation, ΔD , is given by using either the change in the outside circumference or the change in diameter as shown in [Formulae \(2\)](#) and [\(3\)](#).

The change in the outside circumference:

$$\Delta D = \frac{C_1 - C_0}{C_0} \times 100 \quad (2)$$

where

ΔD is the dilation in terms of the change in circumference (%);

C_0 is the outside circumference at the initial condition (mm);

C_1 is the outside circumference at the specified pressure (mm).

The change in diameter:

$$\Delta D = \frac{D_1 - D_0}{D_0} \times 100 \quad (3)$$

where

ΔD is the dilation in terms of the change in outside diameter (%);

D_0 is the sum of two diameters measured at right angles to each other at the initial condition (mm);

D_1 is the sum of two diameters measured at right angles to each other at the specified pressure (mm).

g) **Resistance to electrochemical degradation**

When tested in accordance with method 1 of SAE J1684:2005, hoses and tubing shall not exhibit any internal cracks or "striations".

h) **Resistance to ozone**

When tested in accordance with method 2 of ISO 7326:2016 under the following conditions, the hose or tubing shall not show cracking when examined under 2× magnification:

Partial pressure of ozone: 50 mPa ± 3 mPa

Duration: 72 h ± 2 h

Temperature: 40 °C ± 2 °C

Elongation: 20 %

i) Heat ageing resistance

After ageing for 1 000 h \pm 5 h at 100 °C for type 1, 125 °C for type 2, 150 °C for type 3 or 175 °C for type 4 hose or tubing in accordance with ISO 188, all constructions shall meet the adhesion requirements of test b), the low-temperature flexibility requirements of test c) and the ozone resistance requirements of test h).

j) Compression set

When determined in accordance with SAE J1638 for 24 h \pm 2 h at 100 °C for type 1, 125 °C for type 2, 150 °C for type 3 or 175 °C for type 4 hose or tubing, the compression set of all types of hose and tubing shall not exceed 50 %.

k) Resistance to surface contamination by engine oil

When tested in accordance with Annex B using ISO 1817 oil 3, all constructions shall meet the adhesion requirements of test b), the low-temperature flexibility c) and the resistance to ozone h).

l) Pressure/vibration/temperature test

When tested in accordance with [Annex C](#), all constructions shall meet the adhesion requirements of test b), the low-temperature flexibility requirements of test c) (but with a burst pressure of at least 85 % of the original burst pressure) and the ozone resistance requirements of test h). The change in outside diameter shall be less than 15 %.

The change in burst pressure, ΔP , is given by [Formula \(4\)](#):

$$\Delta P = \frac{P_1 - P_2}{P_1} \times 100 \quad (4)$$

where

ΔP is the change in burst pressure (%);

P_1 is the original burst pressure (MPa);

P_2 is the burst pressure after the low-temperature flexibility test (MPa).

The change in outside diameter is given by [Formula \(5\)](#):

$$\Delta D = \frac{D_1 - D_2}{D_1} \times 100 \quad (5)$$

where

ΔD is the change in outside diameter (%);

D_1 is the original outside diameter (mm);

D_2 is the outside diameter after the test (mm).

6 Frequency of testing

The frequency of type testing and routine testing shall be as specified in [Annex E](#) and [Annex E](#), respectively.

Type tests are obtained by the manufacturer demonstrating that all requirements of this International Standard are met by a particular hose or tubing design manufactured by a particular method. The tests shall be repeated at a maximum of five-year intervals, or whenever a change in the method of manufacture or materials used occurs.

Routine tests shall be carried out on finished lengths of hose or tubing prior to despatch at a frequency agreed by the manufacturer and customer.

Production acceptance tests are those tests, specified in [Annex G](#), which should preferably be carried out by the manufacturer to control the quality of its product. The frequencies specified in [Annex G](#) are given for guidance purposes only.

7 Marking

All constructions shall be continuously marked with the following information:

- a) manufacturer's name or trademark;
- b) number and year of publication of this International Standard, i.e. ISO 4081:2016;
- c) type classification and temperature limit in accordance with [Clause 3](#);
- d) internal diameter, in millimetres;
- e) year and quarter of manufacture;
- f) recycling code for the construction material, in accordance with ISO 1629.

EXAMPLE

MAN/ISO 4081:2016/Type 1 100°C/10/2Q16/EPDM

Where the hose length or shape does not allow marking to the above requirements, marking shall be carried out as agreed between the customer and manufacturer.

Annex A **(normative)**

Dilation test

A.1 Apparatus

A test rig allowing coolant to be pressurized in the hose as a sealed system shall be used. The pressure and temperature shall be constant over the duration of the test.

A.2 Procedure

Attach the hose under test to the pressure rig.

Fill with a mixture of equal volumes of 1,2-ethanediol and distilled water, and seal securely.

Measure the outside circumference or diameter before pressurizing the system.

Raise the pressure to 0,2 MPa (2 bar) and the temperature to 125 °C.

Hold this pressure and temperature for 8 h and then re-measure the outside circumference at the same point under these conditions.

Express the dilation as the percentage increase in circumference or diameter.

Annex B (normative)

Resistance to surface contamination by engine oil

Tightly plug the ends of suitable lengths of hose or tubing to enable the adhesion test [[Clause 5](#), test b)], low-temperature flexibility test [[Clause 5](#), test c)] and ozone resistance test [[Clause 5](#), test h)] to be carried out.

Fully immerse each test piece in the specified contaminating fluid for 2 h at 60 °C.

At the end of the immersion period, wipe the fluid from the surface of the hose or tubing and test, as required.

Annex C (normative)

Pressure, vibration and temperature test

C.1 Apparatus

The pressure, vibration and temperature test apparatus shall be capable of subjecting hose or tubing test pieces to vibrations in the vertical, horizontal and longitudinal directions (see [Figure C.1](#)), and pressure pulses at a specified temperature. The apparatus shall comprise one stationary and one vibrating manifold. The vibrating manifold shall execute a linear motion in each of the directions. It shall be possible to position the stationary and vibrating manifolds so that the test pieces can be mounted in the service operating position or as otherwise specified.

The apparatus shall be capable of operating within the following parameters:

Vibration amplitude	0 mm to 30 mm
Vibration frequency	2 Hz to 15 Hz (sinusoidal)
Pressure pulse	0 MPa to 0,5 MPa (0 bar to 5 bar)
Length of pressure pulse cycle	1 s to 300 s
Pressure rise and fall time	1 s to 300 s
Test fluid temperature	-20 °C to +130 °C (tolerance ± 3 °C)
Test fluid flow rate	5 l/min to 250 l/min
Ambient temperature	-20 °C to +180 °C

Hose/tubing connection to manifold in accordance with ISO 6162-1 for hoses/tubing with inside diameters of 10 mm to 70 mm:

Number of test pieces	2 to 6
-----------------------	--------

C.2 Test pieces

At least two test pieces shall be tested.

C.3 Conditioning of test hoses/tubing

No test shall be carried out within 24 h after hose/tubing manufacture. Test pieces shall be conditioned at standard temperature and humidity (see ISO 23529) for at least 3 h before testing. The conditioning period may be considered as part of the 24 h period after manufacture.

C.4 Procedure

C.4.1 Mount the test pieces on a hose coupling and mount each assembly on the test rig.

C.4.2 Testing shall be performed under the following conditions, unless otherwise stated:

Vibration amplitude	8 mm
Vibration frequency	10 Hz
Pressure pulse	0,07 MPa to 0,20 MPa (0,7 bar to 2 bar) for hoses 0,01 MPa to 0,06 MPa (0,1 bar to 0,6 bar) for tubing
Frequency of pressure pulse cycle	30 s
Test fluid	1,2-ethanediol/water (50/50 by volume)
Test fluid temperature	100 °C (type 1), 125 °C (types 2, 3 and 4)
Test fluid flow rate	20 l/min
Ambient temperature	100 °C (type 1), 125 °C (type 2), 150 °C (type 3), 175 °C (type 4)
Test duration	250 h

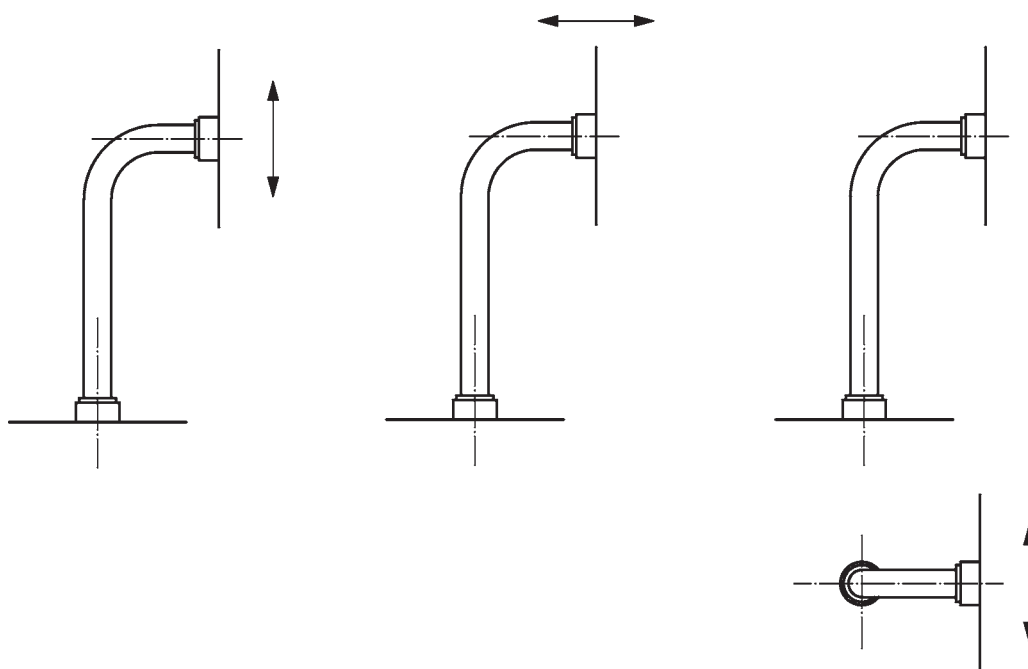

Figure C.1 — Directions of vibration of test piece

Annex D (informative)

Example of how a non-standard type of hose or tubing could be specified by an original equipment manufacturer (OEM) using a matrix

Table D.1 — Hose to ISO 4081:2016, Clause 5

a)	X
b)	X
c)	X
d)	NA
e)	X
f)	X
g)	NA
h)	X
i)	X
j)	X
k)	X
l)	X
z1 ^a	X
z2 ^a	X
X Denotes test required.	
NA Denotes test not applicable.	
^a z1, z2, ..., etc. denote additional tests as specified by the OEM.	

Annex E (normative)

Type test

Table E.1 — Type test

Test (see Clause 5)	All types
a)	X
b)	X
c)	X
d)	X
e)	X
f)	X
g)	X
h)	X
i)	X
j)	X
k)	X
l)	X
X Test shall be carried out.	
NA Test not applicable.	

Annex F (normative)

Routine test

Table F.1 — Routine test

Test	Applicability
Dimensions	X
Test in Clause 5	
a)	NA
b)	NA
c)	NA
d)	NA
e)	NA
f)	NA
g)	NA
h)	NA
i)	NA
j)	NA
k)	NA
l)	NA
X Test shall be carried out.	
NA Test not applicable.	

Annex G (informative)

Production acceptance test

Production acceptance tests are those carried out per batch or 10 batches as indicated in [Table G.1](#). A batch is defined as a maximum of 1 000 m of hose or tubing produced.

Table G.1 — Production acceptance test

Test	Per batch	Per 10 batches
Dimensions	X	X
Concentricity	X	X
Test in Clause 5 :		
a)	X	X
b)	X	X
c)	X	X
d)	X	X
e)	X	X
f)	X	X
g)	NA	X
h)	NA	X
i)	NA	NA
j)	X	X
k)	NA	X
l)	NA	X
X Test shall be carried out.		
NA Test not applicable.		

Bibliography

- [1] ISO 1176, *Road vehicles — Masses — Vocabulary and codes*

