

INTERNATIONAL STANDARD

**ISO
4074**

First edition
2002-02-15

Corrected version
2002-12-01

Natural latex rubber condoms — Requirements and test methods

*Préservatifs masculins en latex de caoutchouc naturel — Exigences et
méthodes d'essai*



Reference number
ISO 4074:2002(E)

© ISO 2002

PDF disclaimer

This PDF file may contain embedded typefaces. In accordance with Adobe's licensing policy, this file may be printed or viewed but shall not be edited unless the typefaces which are embedded are licensed to and installed on the computer performing the editing. In downloading this file, parties accept therein the responsibility of not infringing Adobe's licensing policy. The ISO Central Secretariat accepts no liability in this area.

Adobe is a trademark of Adobe Systems Incorporated.

Details of the software products used to create this PDF file can be found in the General Info relative to the file; the PDF-creation parameters were optimized for printing. Every care has been taken to ensure that the file is suitable for use by ISO member bodies. In the unlikely event that a problem relating to it is found, please inform the Central Secretariat at the address given below.

© ISO 2002

All rights reserved. Unless otherwise specified, no part of this publication may be reproduced or utilized in any form or by any means, electronic or mechanical, including photocopying and microfilm, without permission in writing from either ISO at the address below or ISO's member body in the country of the requester.

ISO copyright office
Case postale 56 • CH-1211 Geneva 20
Tel. + 41 22 749 01 11
Fax + 41 22 749 09 47
E-mail copyright@iso.ch
Web www.iso.ch

Printed in Switzerland

Contents

	Page
1 Scope	1
2 Normative references	1
3 Terms and definitions	1
4 Quality verification	3
5 Design	3
6 Burst volume and pressure	4
7 Tests for stability and shelf life	5
8 Freedom from holes	6
9 Visible defects	6
10 Package integrity	6
11 Packaging and labelling	7
12 Test report	9

Annexes

A Sampling plans intended for assessing compliance of a continuing series of lots of sufficient number to allow the switching rules to be applied	10
B Sampling plans intended for assessing compliance of isolated lots	11
C Determination of total lubricant for condoms in individual containers	12
D Determination of length	14
E Determination of width	16
F Determination of thickness	17
G Determination of bursting volume and pressure	19
H Oven treatment for condoms	22
I Determination of force and elongation at break of test pieces of condoms	23
J Determination of shelf life by real-time stability studies	25
K Guidance on conducting and analysing accelerated ageing studies	27
L Testing for holes	30
M Tests for package integrity	35
N Test report	37
O Calibration of air inflation equipment for determination of burst volume and pressure	38
P Rationale	41
Bibliography	45

Foreword

ISO (the International Organization for Standardization) is a worldwide federation of national standards bodies (ISO member bodies). The work of preparing International Standards is normally carried out through ISO technical committees. Each member body interested in a subject for which a technical committee has been established has the right to be represented on that committee. International organizations, governmental and non-governmental, in liaison with ISO, also take part in the work. ISO collaborates closely with the International Electrotechnical Commission (IEC) on all matters of electrotechnical standardization.

International Standards are drafted in accordance with the rules given in the ISO/IEC Directives, Part 3.

Draft International Standards adopted by the technical committees are circulated to the member bodies for voting. Publication as an International Standard requires approval by at least 75 % of the member bodies casting a vote.

Attention is drawn to the possibility that some of the elements of this International Standard may be the subject of patent rights. ISO shall not be held responsible for identifying any or all such patent rights.

International Standard ISO 4074 was prepared by Technical Committee ISO/TC 157, *Mechanical contraceptives*.

This first edition of ISO 4074 cancels and replaces ISO 4074-1:1996, ISO 4074-2:1994, ISO 4074-3:1994, ISO 4074-4:1980, ISO 4074-5:1996, ISO 4074-6:1996, ISO 4074-7:1996, ISO 4074-8:1984, ISO 4074-9:1996, ISO 4074-10:1990 and ISO 4074-12:1980.

Annexes A, C, D, E, F, G, H, I, J, L, M and N form a normative part of this International Standard. Annexes B, K, O and P are for information only.

This corrected version of ISO 4074:2002 incorporates correction in the Foreword, where the years of publication of the parts of ISO 4074 being replaced by the new edition were erroneously omitted.

Introduction

The intact latex film has been shown to be a barrier to human immunodeficiency virus (HIV), other infectious agents responsible for the transmission of sexually transmitted infections (STIs) and to spermatozoa. In order to help ensure that condoms are effective for contraceptive purposes and for assisting in the prevention of transmission of STIs, it is essential that condoms fit the penis properly, are free from holes, have adequate physical strength so as not to break during use, are correctly packaged to protect them during storage and are correctly labelled to facilitate their use. All these issues are addressed in this International Standard.

The condom and any lubricant, additive, dressing, individual packaging material or powder applied to it should neither contain nor liberate substances in amounts that are toxic, sensitizing, locally irritating or otherwise harmful under normal conditions of storage or use. Reference should be made to ISO 10993 for test methods to evaluate the safety of condoms particularly in respect of the risk of local irritation and sensitization.

Condoms are medical devices. Therefore they should be produced under a good quality management system. Reference should be made, for example to the ISO 9000-series, ISO 14971-1 and one of the relevant standards: ISO 13485 or ISO 13488.

Condoms are non-sterile medical devices but manufacturers should take appropriate precautions to minimize microbiological contamination of the product during manufacture and packaging.

This first edition of ISO 4074 requires manufacturers to conduct stability tests to estimate the shelf life of any new or modified condom before the product is placed on the market and to initiate real-time stability studies. These requirements are described in clause 7. The real-time stability test can be considered as part of the manufacturer's requirement to conduct post-marketing surveillance on their products. These requirements are intended to ensure that manufacturers have adequate data to support shelf-life claims before products are placed on the market and that these data are available for review by regulatory authorities, third-party test laboratories and purchasers. They are also intended to limit the need for third parties to conduct long-term stability studies.

A guideline (ISO 16038) for the application of this International Standard is under development by ISO/TC 157/WG 14.

This International Standard contains requirements for tensile properties (force at break) when a manufacturer makes a claim for "extra strength". Annex I contains the test method for determination of force and elongation at break, as it may be useful in the quality system of a manufacturer and in very special cases in a purchaser's contract.

Background information including technical explanations relating to certain clauses of this International Standard is given in annex P. Where this is relevant, the appropriate clause in annex P is referenced in the text.

Natural latex rubber condoms — Requirements and test methods

1 Scope

This International Standard specifies the minimum requirements and the test methods to be used for condoms made from natural rubber latex which are supplied to consumers for contraceptive purposes and to assist in the prevention of sexually transmitted infections.

2 Normative references

The following normative documents contain provisions which, through reference in this text, constitute provisions of this International Standard. For dated references, subsequent amendments to, or revisions of, any of these publications do not apply. However, parties to agreements based on this International Standard are encouraged to investigate the possibility of applying the most recent editions of the normative documents indicated below. For undated references, the latest edition of the normative document referred to applies. Members of ISO and IEC maintain registers of currently valid International Standards.

ISO 188, *Rubber, vulcanized or thermoplastic — Accelerated ageing and heat resistance tests*

ISO 2859-1:1999, *Sampling procedures for inspection by attributes — Part 1: Sampling schemes indexed by acceptance quality limit (AQL) for lot-by-lot inspection*

ISO 15223, *Medical devices — Symbols to be used with medical device labels, labelling and information to be supplied*

EN 980, *Graphical symbols for use in the labelling of medical devices*

3 Terms and definitions

For the purposes of this International Standard, the terms and definitions given in ISO 2859-1 and the following apply.

3.1

acceptable quality limit

AQL

When a continuous series of lots is considered, the quality level which for the purposes of sampling inspection is the limit of a satisfactory process mean (according to ISO 2859-1)

3.2

condom

medical device used by consumers, which is intended to be retained on the penis during sexual activity, for purposes of contraception and prevention of sexually transmitted infections

NOTE If a consumer could responsibly consider a device to be a condom (due to its shape, packaging, etc.), it is considered a condom for the purpose of this International Standard.

3.3

consumer package

package, intended for distribution to a consumer, containing one or more individual containers

3.4

expiry date

stated date after which a condom should not be used

3.5

identification number

number, or combination of numerals, symbols or letters used by a manufacturer on consumer packages to identify uniquely the lot numbers of individual condoms contained in that package, and from which it is possible to trace those lots through all stages of packaging and distribution

NOTE When the consumer package contains only one kind of condom, then the identification number may be the same as the lot number. But if the consumer package contains several different types of condom, for instance condoms of different shapes or colours, then the identification number will be different from the lot number.

3.6

individual container

immediate wrapping of a single condom

3.7

inspection level

relationship between lot size and sample size.

NOTE For description, see ISO 2859-1:1999, 10.1.

3.8

lot

collection of condoms of the same design, colour, shape, size and formulation, manufactured at essentially the same time, using the same process, raw materials of the same specifications, common equipment and packed with the same lubricant and any other additive or dressing in the same type of individual container

NOTE This International Standard does not specify the size of a lot, but it is possible for a purchaser to do so as part of the purchasing contract. Attention is drawn to the difficulties that can be associated with the distribution and control of very large lots. The recommended maximum individual lot size for production is 500 000.

3.9

lot number

number or combination of numerals, symbols or letters used by the manufacturer to identify a lot of individually packaged condoms, and from which it is possible to trace that lot through all stages of manufacture up to packaging

NOTE For testing purposes, sampling is conducted by lot number, not identification number. See requirements in clause 4.

3.10

lot test

test to assess the compliance of a lot

NOTE A lot test may be limited to include only those parameters which may change from lot to lot.

3.11

non-visible hole

hole in the condom that is not visible under normal or corrected vision but is detected by leakage when rolling on absorbant paper

3.12

sampling plan

specific plan which indicates the number of units of product from each lot which are to be inspected (sample size or series of sample sizes) and the associated criteria for determining the acceptability of the lot (acceptance and rejection numbers)

3.13**shelf life**

time from date of manufacture to the claimed expiry date

3.14**visible hole**

hole or tear in the condom that is visible under normal or corrected vision

4 Quality verification

Condoms are mass-produced articles manufactured in very large quantities. Inevitably there will be some variation between individual condoms, and a small proportion of condoms in each production run may not meet the requirements in this International Standard. Further, the majority of the test methods described in this International Standard are destructive. For these reasons the only practicable method of assessing compliance with this International Standard is by testing a representative sample from a lot or series of lots. Basic sampling plans are given in ISO 2859-1. Reference should be made to ISO/TR 8550 for guidance on the selection of an acceptance sampling system, scheme or plan for the inspection of discrete items in a lot.

When on-going verification is required of the quality of condoms, it is suggested that, instead of concentrating solely on evaluation of the final product, the party concerned also directs his attention to the manufacturer's quality system. In this connection it should be noted that the ISO 9000 series (see Bibliography) covers the provision of an integrated quality system.

Sampling plans shall be selected to provide an acceptable level of consumer protection. Suitable sampling plans are given in annexes A and B.

- a) Annex A describes sampling plans based on ISO 2859-1 and is most applicable to manufacturers or purchasers assessing the compliance of a continuing series of lots. The full level of consumer protection available depends upon the switch to tightened inspection if a deterioration in quality is detected. The switching rules cannot offer full protection for the first two lots tested, but become progressively more effective as the number of lots in a series increases. The sampling plans in annex A are recommended when five or more lots are being tested.
- b) Annex B describes sampling plans, based on ISO 2859-1, that are recommended for the assessment of isolated lots. The sampling plans in annex B provide approximately the same level of consumer protection as those given in annex A when used with the switching rules. It is recommended that these sampling plans be used for the assessment of fewer than five lots, for example in cases of dispute, for referee purposes, for type testing, for qualification purposes or for short runs of continuing lots.
- c) Handling and storage conditions shall be documented before drawing the samples.

It is necessary to know the lot size in order to derive from ISO 2859-1 the number of condoms to be tested. The lot size will vary between manufacturers and is regarded as part of the process and quality controls used by the manufacturer.

5 Design**5.1 Integral bead**

The open end of the condom shall terminate in an integral bead and shall comply with clause 9.

5.2 Lubrication

If the amount of lubricant in the package is specified, then this amount shall be determined by the method described in annex C.

The method in annex C also recovers part of the dressing powder on the condom. (See rationale, in P.7.) An allowance should be made for this when manufacturers or purchasers specify lubricant levels.

5.3 Dimensions

5.3.1 Length

When tested by the method given in annex D, taking 13 condoms from each lot, no individual length measurement shall be below 160 mm.

5.3.2 Width

When tested by the method given in annex E, taking 13 condoms from each lot, no width measurement shall deviate from the nominal width stated by the manufacturer by more than ± 2 mm.

The width shall be measured at the narrowest part of the condom within 35 mm from the open end, or at a point specified by the manufacturer within the same area.

NOTE The width for determination of the requirements for burst volume as in 6.1 may be measured at the same time.

5.3.3 Thickness

If the thickness of the condom is specified, then it shall be determined by the method in annex F.

6 Burst volume and pressure

6.1 Untreated condoms

When tested in accordance with annex G, the bursting pressure shall be not less than 1,0 kPa and the bursting volume (rounded to the nearest 0,5 dm³) shall be not less than:

- 16,0 dm³ for condoms with a width less than 50,0 mm, or
- 18,0 dm³ for condoms with a width greater than or equal to 50,0 mm and up to 56,0 mm, or
- 22,0 dm³ for condoms with a width greater than or equal to 56,0 mm

The width is defined as the mean flat width of 13 condoms measured in accordance with annex E at a point (75 ± 5) mm from the closed end. (See rationale in annex P.)

The compliance level for each lot shall be an AQL of 1,5 for non-conforming condoms.

A non-conforming condom is defined as a condom that fails the requirement for volume, pressure, or both, or any condom that exhibits any leakage.

6.2 Lot testing for oven-treated condoms

The purpose of this test is to check for major formulation or vulcanization errors. When oven-treated as described in annex H for (168 ± 2) h at (70 ± 2) °C and tested according to annex G, the condoms shall meet the requirements of 6.1. This test does not provide information about the shelf life of the product.

This test is applicable only to condoms that are less than one year old from the date of manufacture.

6.3 Extra strength

6.3.1 General

If a manufacturer makes a claim that a particular brand of condoms is stronger or implies that a particular brand of condoms provides extra protection or safety in use because the condoms are stronger than regular condoms, then the additional requirements for “Extra Strength” condoms defined in this section shall apply. (See annex P.)

6.3.2 Requirements for mechanical properties

When tested according to annex G, the minimum bursting pressure shall be not less than 2,0 kPa and the bursting volume shall conform to the requirements of 6.1.

When tested according to annex I, the minimum mean force at break shall be 100 N based on the mean of 13 condoms selected at random from each lot of condoms.

6.3.3 Requirements for clinical data

Manufacturers shall substantiate the extra-strength claims with clinical data or prominently display on the pack the statement given in 11.2.3.2.

The clinical data shall substantiate a statistically significant reduction in breakage rate for the extra strong condom when compared in a random, double blind trial to a reference, marketed condom from normal production produced by the same manufacturer. The reference condom shall comply with the requirements of ISO 4074 and shall exceed 0,060 mm single wall thickness at the mid body.

Useful references are ISO 14155 or EN 540 and ISO 16037 (in preparation).

7 Tests for stability and shelf life

7.1 General

Manufacturers shall verify that the condoms comply with the requirements of 6.1 of this International Standard until the end of the labelled shelf life. Shelf-life claims shall not exceed five years (see annex P).

Data supporting the shelf-life claims made by the manufacturer shall be made available to the appropriate regulatory authorities and direct purchasers upon request.

Before a new or modified condom design is placed on the market, the following requirements shall be met.

- The condom shall be tested for the minimum stability requirements as described in 7.2.
- A real-time study as described in 7.3 to determine shelf life shall have commenced.
- Pending completion of the real-time study, shelf life shall be estimated as described in 7.4.

NOTE 1 A modified condom design is one in which there have been significant changes to the formulation, manufacturing process or individual sealed containers.

NOTE 2 Compliance with the requirements of 7.1 does not imply that the shelf life of the product has been determined.

Shelf-life estimates (7.4) shall be based on a mean kinetic temperature of 30 °C for all climatic conditions and may be carried out on condoms from the same production lots as used for real-time determination of shelf life (7.3).

For existing designs on the market at the date of publication of this International Standard, real-time data in a form consistent with annex J, and at temperatures consistent with local regulatory requirements prevailing at the time the product was introduced, shall be acceptable, to verify the shelf-life claims.

7.2 Minimum stability requirements

Test three lots of condoms for compliance with ISO 4074, except 11.2 and 11.3, using the sampling plans given in annex B.

Only lots meeting all of the requirements of ISO 4074, except 11.2 and 11.3, shall be used for this test.

Incubate samples in their individual sealed containers according to annex H, one set for (168 ± 5) h (1 week) at $(70 \pm 2)^\circ\text{C}$ and the other set for (90 ± 1) days at $(50 \pm 2)^\circ\text{C}$. At the end of the incubation periods, withdraw the condoms and test for airburst properties according to annex G and the requirements of 6.1.

The test report shall include the requirements of annexes G and N.

NOTE Data to verify compliance with 7.2 can be extracted from studies for estimates of shelf life (7.4).

7.3 Procedure for determining shelf life by real-time stability studies

After testing according to annex J the condoms shall meet the requirements in 6.1.

If the real-time data indicate a shorter shelf life than that claimed on the basis of accelerated ageing (7.4), the manufacturer shall notify the relevant regulatory authorities and direct purchasers. The manufacturer shall change the shelf-life claim for the product to one based upon the real-time study. In no case shall shelf life exceed five years. For condoms placed on the market, real-time stability studies shall be completed for the full period of the shelf-life claim.

7.4 Estimating shelf life based upon accelerated stability studies

Pending the completion of real-time studies, accelerated stability studies shall be used to estimate the shelf life.

At the date of publication, no single method of analysis was sufficiently validated or widely used to justify its designation as a standard method. Several approaches to the analysis of accelerated-ageing data have been explored. It is anticipated that as manufacturers and regulatory agencies accumulate real-time data, a consensus method for the next revision of this International Standard will be developed. Meanwhile, the results of accelerated-ageing data may be analysed by a number of methods or as stipulated by the manufacturer's regulatory authority.

Examples of methods for accelerated studies and data analysis are provided in annex K. Data generated from such studies shall support the claim that the condoms fulfil the requirements in 6.1 for the duration of the labelled shelf life at 30°C .

8 Freedom from holes

When tested by either method described in annex L, the compliance level for each lot, for the sum of condoms with visible and non-visible holes and tears, shall be an AQL of 0,25.

9 Visible defects

For visible defects as described in annex L (L.2.3.3, L.3.3.4), the compliance level for each lot shall be an AQL of 0,4.

10 Package integrity

When requested by a customer or a regulatory body, the manufacturer or supplier shall provide information on package integrity based upon the test method given in annex M. The compliance level for each lot shall be an AQL of 2,5.

11 Packaging and labelling

11.1 Packaging

Each condom shall be packed in an individual container. One or more individual containers may be packed in other packaging such as a consumer package. The individual container, or consumer package or both, shall be opaque to light. However packaged, the packaging shall protect the condom from light even if only the individual package is provided to the consumer.

If a marking medium, such as ink, is used on a condom or on any part of a package directly in contact with a condom, it shall not have any deleterious effect on the condom or be harmful to the user.

Individual containers and any other packaging shall protect the condom from damage during transport and storage.

Individual containers and any other packaging shall be designed in such a way that the pack can be opened without damaging the condom. The design of the individual container should facilitate easy opening. (See rationale in annex P.)

11.2 Labelling

11.2.1 Symbols

If symbols are used on packaging, information and marketing materials, the symbols shall meet the requirements in ISO 15223 or EN 980.

11.2.2 Individual container

Each individual container shall bear at least the following information:

- a) the identity of the manufacturer or distributor. (See rationale in annex P);
- b) the manufacturer's identifying reference for traceability (e.g. the lot number);
- c) the expiry date (year, month). The format of the year shall be in four digits; the format of the month shall be in letters or two digits. (See rationale in annex P.)

11.2.3 Consumer package

11.2.3.1 General

The outside of the consumer package shall bear at least the following information in at least one of the official language(s) of the country of destination or as stipulated differently by that country:

- a) a description of the condom, including whether or not it has a reservoir. If the condom is coloured or textured this shall be stated;
- b) the number of condoms contained;
- c) the nominal width of the condom;
- d) the name or trade name and address of the manufacturer and/or distributor, depending on national and regional requirements. (See rationale in annex P);
- e) the expiry date (year and month). The format of the year shall be in four digits and the format of the month shall be in letters or two digits. If a consumer package includes condoms from different lots, the earliest expiry date shall apply to all condoms;
- f) a statement to store the condom in a cool dry place away from direct sunlight;

- g) a statement that individual containers, if not opaque to light, should not be stored outside the opaque consumer package;
- h) whether the condom is lubricated or dry. When a medicinal ingredient is added, it shall be identified and its purpose indicated (e.g. spermicidal). If the condom or lubricant is fragranced or flavoured, this shall be stated;
- i) the manufacturer's identifying reference for traceability (e.g. the identification number/lot number). If different types of condoms, e.g. different colours, are packaged together in the same consumer package, the identification number on the consumer package shall allow the manufacturer to identify uniquely the lot numbers of the individual condoms contained in that package, so that it is possible to trace those lots through all stages of manufacture up to packaging;
- j) a statement that the condom is made of natural rubber latex.

11.2.3.2 Labelling of extra-strong condoms

A claim such as "extra strong" implies that the condoms have a lower level of breakage than a "regular" condom. Such claims shall be supported by clinical investigations. (See 6.3.3.)

If the manufacturer wishes to use the claim "extra strong" pending the completion of a clinical study, the labelling shall state:

"This extra-strong condom has not been shown to be safer in use than regular condoms."

11.2.4 Additional information on the consumer package

The outside or the inside of the consumer package, or a leaflet contained within the consumer package, shall bear at least the following information expressed in simple terms, and in at least one of the official language(s) of the country of destination, if possible supplemented by pictorial representations of the major steps involved or as stipulated differently by that country.

- a) Instructions for use of the condom, including
 - 1) the need to handle the condom carefully, including removal from the package so as to avoid damage to the condom by fingernails, jewellery etc.;
 - 2) how and when to put on the condom; mention should be made that the condom should be placed on the erect penis before any contact occurs between the penis and the partner's body to assist in the prevention of sexually transmitted infections and pregnancy;
 - 3) the need to withdraw the penis soon after ejaculation, while holding the condom firmly in place at the base of the penis;
 - 4) the need, if an additional lubricant is desired, to use the correct type of lubricant which is recommended for use with condoms and the need to avoid the use of oil-based lubricants such as petroleum jelly, baby oil, body lotions, massage oils, butter, margarine etc. as these are deleterious to the integrity of the condom;
 - 5) the need to consult a doctor or pharmacist about the compatibility of topical medicines that may come in contact with the condom.
- b) Instructions on how to dispose of the used condom.
- c) A statement that the condom is for single use.
- d) The number of this International Standard, i.e. ISO 4074. (See rationale in annex P.)

11.3 Inspection

From each lot, 13 consumer packages and 13 individual containers shall be inspected for compliance. All inspected containers shall comply with the requirements.

Under certain conditions it may be permissible for the manufacturer/distributor to correct faults associated with packaging and labelling requirements and resubmit the lot for further conformity testing. Examples include insertion

of missing instruction leaflets or re-packaging of individual containers into new complete consumer packages before placing on the market.

If condoms from the same lot are packed into different consumer packages, then at least one consumer package of each variant should be inspected. The number of packages inspected should not exceed 13 unless the number of variants exceeds 13.

12 Test report

Test reports shall contain at least the information as described in annex N.

Annex A
(normative)

Sampling plans intended for assessing compliance of a continuing series of lots of sufficient number to allow the switching rules to be applied

A.1 Quality verification

When on-going verification is required of the quality of condoms, it is suggested that, instead of concentrating solely on evaluation of the final product, the party concerned also directs his attention to the manufacturer's quality system. In this connection it should be noted that the ISO 9000 series (see Bibliography) covers the provision of an integrated quality system.

A.2 Sampling plans and compliance levels

If a party wishes to establish, by inspection and testing of samples of the final product, whether a continuing series of lots are in compliance with the requirements of this International Standard, the sampling plans and acceptance criteria given in Table A.1 shall be applied.

Manufacturers may use the schemes in Table A.1 or may devise and implement validated alternative quality control methods that result in at least equivalent consumer protection.

When tests are being conducted on fewer than five lots of condoms, the additional protection of the switching rules in ISO 2859-1 is not available and it is recommended that the sampling plans given in annex B be used to maintain the level of consumer protection.

Table A.1 — Sampling plans and acceptance criteria for a continuing series of lots

Attributes	Inspection level	Acceptance criteria
Dimensions	13 condoms	All samples shall meet the criteria of length ≥ 160 mm and width ± 2 mm of stated nominal width
Bursting volume and pressure (untreated/oven-treated)	General Inspection Level I as in ISO 2859-1	AQL of 1,5
Package integrity	Special Inspection Level S-3	AQL of 2,5
Freedom from holes	General Inspection Level I but at least code Letter M	AQL of 0,25
Visible defects	General Inspection Level I but at least code Letter M	AQL of 0,4
Packaging and labelling	13 consumer packages and 13 individual containers	All shall comply

Applications for these sampling plans may include the following:

- a) on-going production testing and quality control by a manufacturer;
- b) on-going testing by a purchaser for contractual purposes;
- c) on-going inspection by a national authority.

Annex B (informative)

Sampling plans intended for assessing compliance of isolated lots

Use of the sampling plans given in annex A for small numbers of lots, i.e. fewer than five, will result in a higher level of consumer risk because the switching rules are not available. In such circumstances the use of larger sample sizes is recommended in order to maintain an acceptable level of consumer protection. The choice of a suitable sampling plan will be governed by cost considerations. Larger sample sizes will give better discrimination but at increased cost. Purchasers may, for example, rely upon their experience with a particular supplier when assessing the sample sizes to use for small numbers of lots.

The sampling plans given in Table B.1, when applied to isolated lots, provide approximately the same level of consumer protection as those given in annex A when used in conjunction with the switching rules. Attention is drawn to the possibility of using Double or Multiple Sampling Plans which may reduce the total number of condoms that need to be tested to demonstrate compliance when quality is significantly better than the AQL's.

NOTE There is no simple mathematical relationship between the sample size and the lot size. Sample sizes may be increased independently of the lot size to achieve a more reliable estimate of lot quality.

Table B.1 — Sampling plans and acceptance criteria for isolated lots

Attributes	Inspection level	Acceptance criteria
Dimensions	13 condoms	All samples shall meet the criteria of length ≥ 160 mm and width ± 2 mm of stated nominal width
Bursting volume and pressure (untreated/overtreated)	General Inspection Level I but at least Code Letter M as in ISO 2859-1	AQL of 1,5
Package integrity	Special Inspection Level S-3 but at least code letter H	AQL of 2,5
Freedom from holes	General Inspection Level I but at least Code Letter N	AQL of 0,25
Visible defects	General Inspection Level I but at least Code Letter N	AQL of 0,4
Packaging and labelling	13 consumer packages and 13 individual containers	All must comply

Applications for these sampling plans may include the following:

- a) type testing as part of a certification procedure;
- b) cases where the total number of lots being assessed is insufficient to allow the switching rules to be effective;
- c) in cases of dispute involving isolated lots, e.g. for referee testing.

Annex C (normative)

Determination of total lubricant for condoms in individual containers

C.1 Principle

The mass loss is determined by removing the lubricant from the pack and condom by washing with a solvent. Washing is carried out either in an ultrasonic bath or by manual agitation. A minimum sample size of 13 condoms is recommended.

C.2 Apparatus

C.2.1 Ultrasonic cleaning bath(s) or suitable container, e.g. beaker, **and stirrer**.

C.2.2 Balance, accurate to 1 mg.

C.2.3 Propan-2-ol, laboratory reagent grade.

C.3 Procedure

C.3.1 Weigh each individual container to the nearest 1 mg and record the results.

C.3.2 Slit the individual container carefully around three edges and remove the undamaged condom.

C.3.3 Before unrolling the condom cut up one side using scissors, then unroll the condom and wipe it and its individual container free of lubricant as much as possible.

C.3.4 When using the ultrasonic bath, immerse the condom and individual container in propan-2-ol in an ultrasonic bath and wash for 2 min to 10 min. Repeat the washing in clean propan-2-ol as many times as necessary to achieve constant mass after two successive washes (within 10 mg), after drying as below in C.3.6 and C.3.7.

C.3.5 When washing the condoms manually: immerse the condom and individual container in propan-2-ol in a bath and wash with manual agitation. Repeat the washing in clean propan-2-ol as many times as necessary to achieve constant mass after two successive washes (within 10 mg), after drying as below in C.3.6 and C.3.7.

C.3.6 Remove the condom and individual container from the propan-2-ol and wipe to remove excess propan-2-ol.

C.3.7 Dry the condom and individual container to constant mass (within 10 mg) at a temperature not exceeding 55 °C.

C.3.8 Weigh each dry condom and individual container to the nearest 1 mg and subtract this result from that found in C.3.1 to give the total quantity of lubricant.

C.4 Accuracy of lubricant recovery

In an interlaboratory study, this method was shown to recover about 85 mg more "lubricant" than the amount that was added when the test samples were made. This excess "lubricant" is partly dressing powder, which is also removed by the method (see rationale in annex P).

C.5 Expression of results

The amount of lubricant recovered is reported to the nearest 50 mg.

Annex D (normative)

Determination of length

D.1 Principle

The unrolled condom is allowed to hang freely over a graduated mandrel and its length, excluding the reservoir end, is observed and recorded.

D.2 Apparatus

D.2.1 Mandrel with a scale divided into millimetres and having the dimensions shown in Figure D.1, with the zero beginning at the rounded end.

D.3 Procedure

D.3.1 Move the condom inside the package such that it is away from the area where the package is to be torn. Tear the package and remove the condom.

In no circumstance use scissors or other sharp instruments to open the package.

D.3.2 Unroll the condom, stretch it slightly twice but by no more than 20 mm to smooth out the wrinkles caused by the condom having been rolled up. Lubricants may be removed and suitable powders may be added to avoid sticking. (See rationale in annex P.)

D.3.3 Put the condom over the mandrel (D.2.1) and let it hang freely, stretched only by its own mass.

D.3.4 Note, to the nearest millimetre, the smallest value of the length of the condom that can be read on the scale outside the open end of the condom.

D.3.5 Condoms subjected to this test may also be used for determination of width.

D.4 Expression of results

The test report shall include elements from annex N and the length of each tested condom.

Dimensions in millimetres

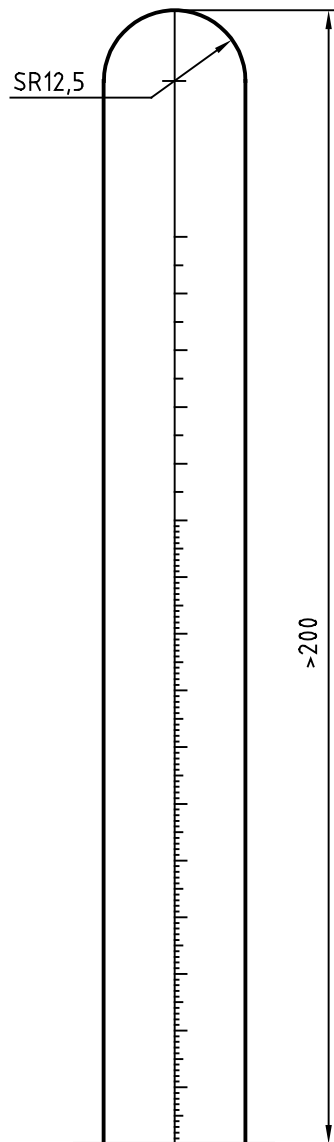

^a SR = spherical radius

Figure D.1 — Mandrel for determining length of condom

Annex E (normative)

Determination of width

E.1 Principle

The unrolled condom is allowed to hang freely over the edge of a ruler and its width is observed and recorded.

E.2 Apparatus

E.2.1 Ruler, with a scale divided into millimetres.

E.3 Procedure

E.3.1 Move the condom inside the package such that it is away from the area where the package is to be torn. Tear the package and remove the condom.

In no circumstance use scissors or other sharp instruments to open the package.

E.3.2 Unroll the condom and lay it flat over the edge of the ruler (E.2.1), perpendicular to the condom's axis, allowing it to hang freely. If a lubricated condom doesn't hang freely, then the lubricant shall be removed and suitable powders may be added to avoid sticking. (See rationale in annex P.)

E.3.3 Measure, to the nearest 0,5 mm, the width of the condom at a point specified in the relevant sections of this standard.

E.3.4 Condoms subjected to this test may also be used for determination of length.

E.4 Expression of results

The test report shall include elements from annex N and the width of each tested condom, including the point along the condom at which the measurement was made.

Annex F (normative)

Determination of thickness

F.1 Principle

This annex describes the test method for determining the thickness of latex rubber condoms.

A condom is laid flat and a test specimen is die-cut from it and weighed. Using the mass, the area of the die-cut specimen, and a density of $0,933 \text{ g/cm}^2$, the thickness is calculated.

The thickness values obtained using this method on textured condoms should be used with caution, since they will be the average of the textured and the smooth portions.

F.2 Apparatus

F.2.1 Laboratory scale, accurate to 0,1 mg.

F.2.2 Cutting die in accordance with I.2.1.

F.2.3 Hydraulic, pneumatic or mechanical press, suitable for die cutting.

F.2.4 Ruler, graduated in 0,5 mm.

F.3 Procedure

F.3.1 Move the condom inside the package such that it is away from the area where the package is to be torn. Tear the package and remove the condom.

Under no circumstances use scissors or other sharp instruments to open the package.

F.3.2 Unroll the condom ensuring that it is not excessively stretched in any direction and powder the condom.

F.3.3 Lay the condom flat with its length at right angles to the cutting edge of the die. Obtain the test piece by cutting the condom with one stroke of the press when the die is positioned with its centre (30 ± 5) mm from the open end of the condom.

F.3.4 Cut the ring open and measure the length, to the nearest 0,5 mm, of one edge with the ruler. If the condom is not parallel-sided, measure both edges and calculate the mean. Calculate the area as the obtained length, in millimetres, $\times 20$.

F.3.5 Repeat F.3.3 and F.3.4 at (30 ± 5) mm from the closed end and at the mid-point between the open and closed ends of the condom.

F.3.6 Wash the specimens in propan-2-ol and dry to constant mass, ± 10 mg.

F.3.7 Weigh the three test specimens separately to the nearest 0,1 mg and record the individual values.

F.3.8 Calculate the thickness of each specimen as follows:

$$t = \frac{1}{\rho} \cdot \frac{1}{A} \cdot m$$

where

- t is the thickness of the test specimen, in millimetres;
- ρ is the density of the latex rubber = 0,933 g/cm³;
- A is the area of the test specimen, in square millimetres;
- m is the mass of the test specimen, in milligrams.

NOTE Condom thickness can be measured with a micrometer gauge, but this method has been shown to give consistently lower results. If a micrometer is used, a suitable type is a dial or digital type, accurate to 0,001 mm, with foot diameter (5 ± 2) mm, and foot pressure (22 ± 4) kPa, parallel to a flat baseplate.

F.4 Expression of results

The test report shall include the elements of annex N and the following particulars:

- a) the calculated thickness of each die-cut specimen;
- b) the average calculated thickness of each tested condom.

Annex G (normative)

Determination of bursting volume and pressure

G.1 Principle

A specified length of the condom is inflated with air, and the volume and pressure required to burst the condom are recorded.

Recommendations on system calibration are given in annex O.

G.2 Apparatus

G.2.1 Inflation apparatus, for example as in Figure G.1, suitable for inflating the condom with clean oil-free and moisture-free air at a specified rate, provided with equipment for measuring volume and pressure and having the following features:

- a) a pressure sensor configured such that there is no pressure differential between the condom and the pressure sensor;
- b) an apparatus for recording the volume of inflation air, configured such that there is no pressure differential between the measuring device and the condom, thereby ensuring that the volume of air is measured or calculated at the appropriate pressure within the condom and not at the line pressure which may be higher;
- c) rod, of suitable length having a smooth sphere or hemisphere 25 mm in diameter at its top for hanging the unrolled condom when fixed to the apparatus, and fixed in a position such that when the condom is clamped the length of the condom, excluding reservoir, remaining for inflation is (150 ± 3) mm;
- d) pressure- and volume-measuring equipment capable of:
 - 1) a maximum permissible limit of error of $\pm 3\%$ for volumes greater than 10 dm^3 , whatever method is used to measure volume;
 - 2) measuring the pressure at burst of the condom with a maximum permissible limit of error of $\pm 0,05 \text{ kPa}$.

G.2.2 Clamping device, for example a clamping ring, having no sharp edges or protrusions.

The recommended material of construction is transparent plastic. The clamping ring should not stretch the condom as the clamping ring is placed onto its mount.

When used with an air-inflated cuff mount, the clamping ring should have a internal diameter of 36 mm to 40 mm, recommended height 50 mm and extend no more than 3 mm above the air-inflated cuff. The cuff should deflate to such a diameter that the condom freely rolls over it.

G.2.3 Inflation cabinet, having a facility for viewing the condom during inflation, and of sufficient size to allow the condom to expand freely without touching any part of the cabinet.

G.3 Procedure

G.3.1 Carry out the test under controlled temperature of $(25 \pm 5) ^\circ\text{C}$.

G.3.2 Move the condom inside the package such that it is away from the area where the package is to be torn. Tear the package and remove the condom.

In no circumstances use scissors or other sharp instruments to open the package.

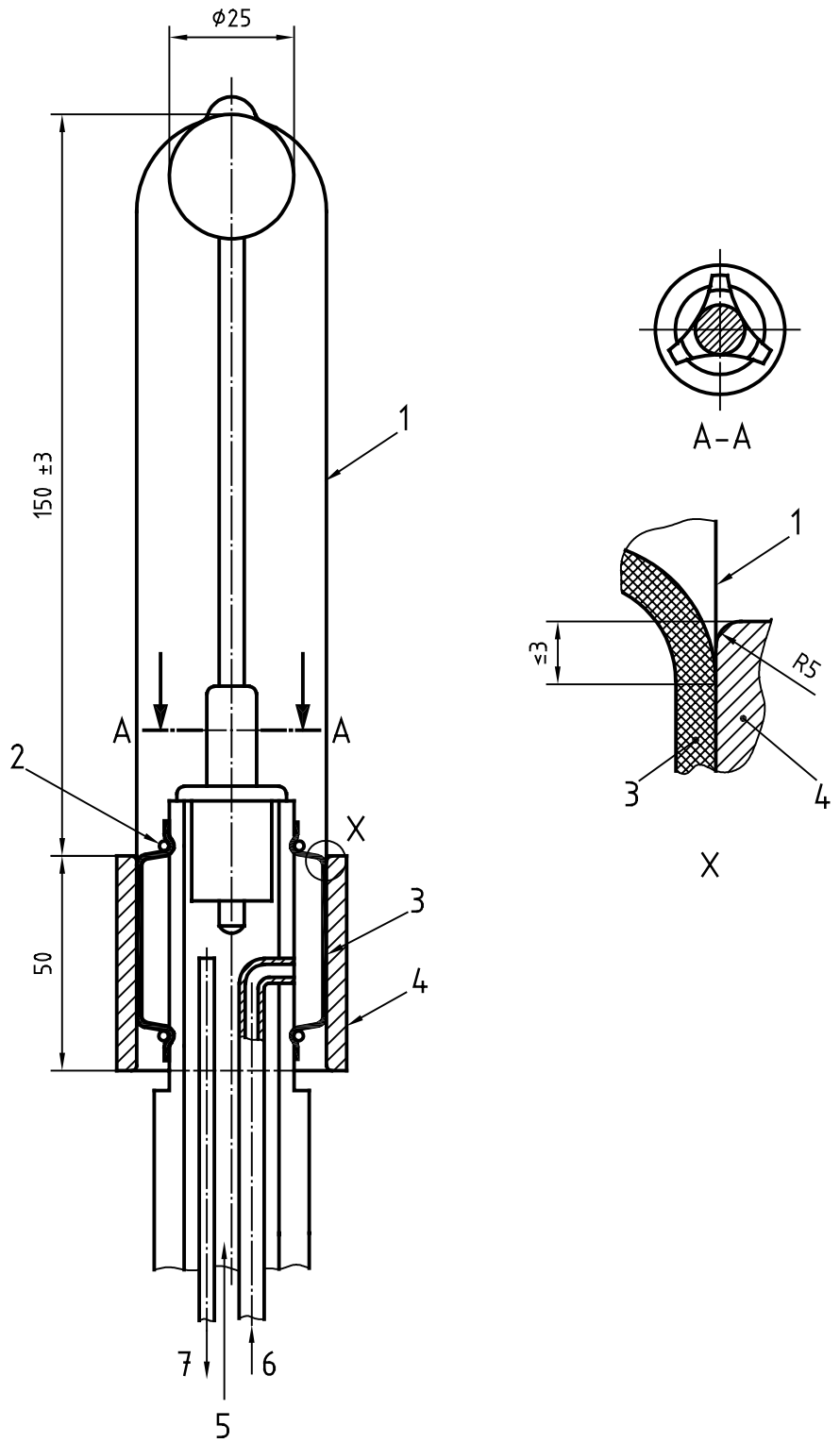

Key

- 1 Condom
- 2 Cord
- 3 Flexible expansion cuff
- 4 Clamping collar of clear plastics
- 5 Air inlet for testing
- 6 Air inlet for keeping condom in place
- 7 To pressure-measuring device

Figure G.1 — Example of suitable apparatus for determining bursting characteristics

G.3.3 It is recommended that suitable gloves or finger cots be worn while handling the condom. In cases of dispute, gloves shall be worn.

G.3.4 Unroll the condom ensuring that it is not excessively stretched in any direction.

NOTE The condom may be unrolled directly onto the rod on the test equipment.

G.3.5 Hang the condom on the rod [G.2.1 c)] and affix to the mount (G.2.2). Take care when placing the clamping ring on its mount to avoid damaging or stretching the condom. Inflate with air at a rate of (0,4 to 0,5) dm³/s [(24 to 30) dm³/min]. Check to ensure that the condom expands and that there are no obvious leaks.

If the condom exhibits any obvious leaks, or leaks are detected during the inflation, discontinue the test. The condom is deemed to fail the test, and the bursting volume and pressure are recorded as zero.

G.3.6 If the condom does not leak, measure and record the bursting volume, in cubic decimetres rounded to the nearest 0,5 dm³, and the bursting pressure, in kilopascals rounded to the nearest 0,05 kPa.

G.4 Expression of results

The test report shall include elements from annex N and the bursting volume and bursting pressure of each tested condom.

Annex H (normative)

Oven treatment for condoms

H.1 Principle

Oven treatment is used to condition condoms for lot testing and for shelf-life determination. This annex describes the method for oven treatment.

H.2 Apparatus

H.2.1 Oven, of either type specified in ISO 188 but air circulation and suspension of the individual packages, as indicated in ISO 188, are not required.

H.3 Preparation of condoms for test

Before testing, rubber condoms shall be conditioned in their original individual packages (i.e. remove the individual container from the consumer and/or outer packaging before conditioning).

H.4 Procedure

H.4.1 Condition the condoms in an oven at the temperature stipulated in the relevant clause or annex of this International Standard.

Rubber condoms shall be mounted so as to minimize direct contact of the specimens with the heated surfaces, especially the base of the oven, and thus ensure even heating of the rubber condoms during oven ageing.

H.4.2 Remove the condoms from the oven after the time stipulated in the relevant clause or annex of this International Standard, and keep the packages at $(25 \pm 5) ^\circ\text{C}$ until tested.

H.4.3 Within 96 h but not sooner than 12 h after removal from the oven, determine bursting volume and pressure in accordance with annex G.

Annex I (normative)

Determination of force and elongation at break of test pieces of condoms

I.1 Principle

A test piece is cut from a condom and stretched it until it breaks; the force and elongation at break can be measured. For the purposes of this International Standard, only the force at break requirement related to 6.3 is applicable. (See rationale in annex P.)

I.2 Apparatus

I.2.1 Cutting die, consisting of two parallel knives ($20 \pm 0,1$) mm apart set in a press above a suitable board. The length of the cutting edge of each knife shall be not less than 70 mm.

I.2.2 Tensile testing machine, capable of an essentially constant rate of traverse and complying with the following requirements:

- a) capable of equalizing the stress within a specimen, either by rotating one roller mechanically at a rotation frequency of approximately 7 min^{-1} or by lubricating the cylindrical surfaces of the rollers with a material that does not affect the latex film. A suitable lubricant is silicone fluid of viscosity $2 \times 10^{-4} \text{ m}^2 \cdot \text{s}^{-1}$ (200 cSt);
- b) capable of determining the breaking load in the range 0 N to 200 N. Maximum permissible values: accuracy $\pm 1 \%$, repeatability 1 %, reversibility 1,5 %, zero ± 1 and with a machine resolution of 0,5 %;
- c) having a roller separation speed of $(8,5 \pm 0,8) \text{ mm/s}$ [$(500 \pm 50) \text{ mm/min}$];
- d) having manual or preferably automatic recording of the separation distance of the rollers and of the load during the test.

I.3 Preparation of test specimen

I.3.1 Move the condom inside the package such that it is away from the area where the package is to be torn. Tear the package and remove the condom.

Under no circumstances use scissors or other sharp instruments to open the package.

I.3.2 Unroll the condom ensuring that it is not excessively stretched in any direction.

I.3.3 Lay the condom flat with its length at right angles to the cutting edge of the die (I.2.1). Obtain the test piece by cutting the condom with one stroke of the press if possible, taking the test piece from a parallel-sided, non-textured region including the portion 80 mm from the open end. If the portion 80 mm from the open end is not parallel-sided or is textured, take the test piece from an adjacent parallel-sided, non-textured region. If no region of the condom is parallel-sided and non-textured, take the test piece from the region 80 mm from the open end.

I.3.4 Lay the test piece flat and put the ruler on top and measure, to the nearest 0,5 mm, the distance between the two folded edges. Lubricants may be removed and suitable powders may be added to avoid sticking. Extra care shall be taken when cutting the samples, and each sample should be inspected before testing to make sure that there are no nicks or other edge defects that could give rise to poor results. (See rationale in annex P.)

I.4 Procedure

I.4.1 Carry out the test under controlled conditions of $(25 \pm 5) ^\circ\text{C}$ and $(55 \pm 15) \%$ relative humidity.

I.4.2 Place the test piece over the rollers of the tensile testing machine (1.2.2) and stretch it until it breaks.

I.4.3 At break, record the load, to the nearest 0,5 N, and the separation distance, to the nearest millimetre, between the centres of the rollers.

I.5 Calculation of results

I.5.1 Record the force at break (F_b) in newtons.

I.5.2 When requested, calculate elongation at break (E) as a percentage of each test piece by using the following expression:

$$E = \frac{l_1 + 2d - l_2}{l_2} \times 100$$

where

l_1 is the length of the test piece, in millimetres, rounded to the nearest millimetre, in contact with the rollers (equal to 47 mm with rollers of diameter 15 mm);

d is the final distance, in millimetres, between the centres of the rollers;

l_2 is the original perimeter of the test piece, in millimetres (twice the distance obtained in 1.3.4).

Round the result to the nearest 10 %.

NOTE The tensile strength can be calculated from the following formula: Tensile strength (MPa) = $0,933 F_b \cdot w \cdot m$ where F_b is the force at break (newtons), w is the mean flat width (millimetres), and m is the mass (milligrams) of the test piece; and round to the nearest 0,1 MPa.

Annex J (normative)

Determination of shelf life by real-time stability studies

J.1 Principle

Packaged condoms are conditioned at 30 °C for the intended shelf-life period and then burst volume and pressure tested for compliance with 6.1. Small samples are removed and inflation tested periodically to monitor changes during the ageing period.

For purposes of this International Standard, oven conditioning at 30 °C has been selected to accommodate storage conditions world-wide.

J.2 Procedure

J.2.1 General

After determining compliance with clause 5, 6.1, 6.2, clauses 8 and 9, sufficient condoms shall be placed in a controlled environment and conditioned to

- a) assess mean and standard deviation of air burst values (32 condoms per interval) at intervals of 1 year or less, and
- b) carry out tests for compliance with 6.1 at the end of the intended shelf life, or earlier where warranted by changes in the above data, in accordance with the sampling plans given in annex B.

Shelf life shall be confirmed if condoms meet the requirements of 6.1 after storage for a period equal to the intended shelf-life claim.

J.2.2 Testing

- a) Test three lots of condoms packed in their respective individual containers for compliance with clause 5, 6.1, 6.2, clauses 8 and 9, using the sampling plans given in annex B.
- b) Conditioning according to annex H shall be carried out at (30 ± 2) °C in a controlled environment.
- c) Condition sufficient condoms per lot to allow:
 - 1) at least 32 condoms to be tested at intervals of one year or less over the duration of the proposed shelf-life period (suggested minimum 200 condoms).
 - 2) sufficient additional condoms to allow bursting volume and pressure to be assessed at the end of the proposed shelf-life period for compliance with 6.1 using the sample sizes given in annex B.

It is strongly recommended that additional condoms be conditioned as spares in case there is a need for any retesting or in case additional timepoints are required.

- d) Remove condoms (at least 32 per lot) from the controlled environment at intervals of one year or less.
- e) Determine bursting volume and pressure according to annex G.
- f) Plot the mean and standard deviation of the bursting pressure and volume against time for each lot.
- g) At the end of the proposed shelf-life period, or if the mean and standard deviation of the burst properties as monitored in f) above deteriorate to the point where the condoms may be approaching the limit of complying with

the air burst requirements of 6.1, test sufficient condoms per lot using the sampling plan in annex B for bursting volume and pressure according to annex G. Assess compliance with the air burst requirements of 6.1.

NOTE The condoms should be considered to be at risk of approaching the limits of compliance with air burst requirements when the difference between the mean and the limit in 6.1 is less than 2 to 3 standard deviations.

h) Assess compliance with 6.1.

J.3 Confirmation of shelf-life claim

Upon completion of J.2, the shelf-life claim shall be up to that period, not to exceed 5 years, for which the condoms have complied with the requirements of 6.1 of ISO 4074.

If the labelled shelf life is more than the confirmed shelf life, adjust the shelf-life claim and notify the regulatory authorities and direct purchasers.

J.4 Test report

The test report shall include the requirements of annex F in the form specified by annex N and:

- a) the plot of bursting pressure and volume against time, as determined according to J.2.2 f);
- b) number of nonconforming units and distribution curves, as determined according to J.2.2 h);
- c) the confirmed shelf-life claim.

Interim test reports shall be made available to appropriate regulatory bodies on request, to document that the real-time study has begun.

Annex K (informative)

Guidance on conducting and analysing accelerated ageing studies

K.1 Principle

Accelerated ageing studies can be used to estimate provisional shelf lives. This annex describes a general protocol that may be used for conducting accelerated aging studies to estimate shelf life for market introduction while real time studies are in progress. It also offers guidelines on analysing these studies to predict shelf life.

K.2 Procedure for conducting accelerated ageing studies

Condition condoms from three production lots in ovens at selected temperatures in accordance with annex H. At appropriate time intervals, remove samples of condoms from the oven, and determine the air bursting properties according to annex G. It is recommended that a minimum of four elevated temperatures be used. Temperatures higher than 80 °C are not advised. A minimum of five time points at each temperature is recommended and the study should continue for at least 120 days and preferably 180 days. It is recommended that at least 32 condoms be tested at each time/temperature point.

If the results are to be compared with those for a condom for which real-time stability data is available, then equivalent samples of that condom should be conditioned at the same time.

If data in support of minimum stability requirements (7.1) are to be extracted from the study, the selected temperatures should include 50 °C and 70 °C.

K.3 Analysis of accelerated ageing data to estimate provisional shelf-life

At the date of publication of this International Standard, no single method of analysis was sufficiently validated or widely used to justify its designation as a standard method. Several approaches to the analysis of non-linear Arrhenius-type plots have been explored. It is anticipated that as manufacturers and regulatory agencies accumulate real-time data, a consensus method for the next revision of this International Standard will be developed.

Meanwhile, the results of accelerated ageing data may be analysed by a number of methods or as stipulated by the manufacturer's regulatory authority. One method is described in detail in K.5. Another method has been published as the P&K method [27]. Yet another method is to compare the rates of change of burst properties with those of a condom of similar formulation for which the shelf life has already been determined by a real-time study. Manufacturers are not limited to these specific methods and are encouraged to investigate these and other methods.

K.4 Test of shelf-life estimates

Once the shelf life of the condom has been estimated, it is necessary to confirm that condoms selected from three lots will be able to comply with the requirements of 6.1 after completion of the thermal challenge equivalent to the proposed shelf life at 30 °C. For convenience the ageing temperatures can be selected as 70 °C and 50 °C and, providing the ageing periods at these temperatures equal or exceed 7 days at 70 °C and 90 days at 50 °C, then this test can also be used to verify the requirements of 7.1.

- a) Select a set of accelerated ageing conditions equivalent to the estimated shelf life at the proposed climatic temperature. The ageing conditions should be chosen with a view to replicating the mode of failure at 30 °C that is predicted by the stability study.
- b) Take samples of condoms packaged in individually sealed containers from three lots. The same three lots should be used as for the accelerated ageing study. Condition the samples according to annex H at the selected ageing temperature for the selected time. Test the samples for compliance with the air burst requirements defined in 6.1.

K.5 Guidance on analysing accelerated ageing studies using the Arrhenius equation

K.5.1 Background to applying the time-temperature superposition method

For many products, shelf-life estimates can be predicted by extrapolation from accelerated ageing studies using the Arrhenius equation. Details of the procedure are given in ISO 11346.

Applying the Arrhenius equation to condoms is difficult because the rates of change in properties can be inconsistent and small, particularly at lower temperatures. The resulting plots themselves are typically non-linear at lower temperatures.

An alternative to constructing the Arrhenius plot is to shift the plots of property against time along the time axis to construct a master curve as described by Barker [23], [24]. In this procedure the time values at each temperature are transformed to equivalent times at a common reference temperature by multiplying them by the Arrhenius shift factor, a_T , which is derived from the Arrhenius equation:

$$a_T = \exp \left\{ E_a \left(\frac{1}{T_{(ref)}} - \frac{1}{T_{(age)}} \right) / R \right\} \tag{K.1}$$

where

E_a is the activation energy;

R is the gas constant (8,31 432 J/K);

$T_{(ref)}$ and $T_{(age)}$ are the reference and ageing temperatures respectively, in kelvin.

The physical properties obtained at the various ageing temperatures are plotted against the respective transformed times on a common graph. If the ageing properties transform according to the Arrhenius equation and the correct value is used for the activation energy, then a single master curve is obtained. The properties of the condom after any period of ageing at the reference temperature can be readily read off the resulting curve.

Studies [23], [24], [25], [26] on natural rubber vulcanizates prepared from dry rubber have determined the activation energy for the oxidation of natural rubber to be in the range 84 kJ/mol to 117 kJ/mol. The activation energy used to calculate the mean kinetic temperatures for the different climatic zones is 83 kJ/mol (Grimm [26]). It is recommended that an activation energy of 83 kJ/mol be used. Using this value for the activation energy, which is at the lower end of the published range for rubber oxidation, has the advantage that shelf-life estimates extrapolated from elevated temperatures will be conservative. For convenience the Arrhenius shift factors based on an activation energy of 83 kJ/mol and a reference temperature of 30 °C are listed in Table K.1.

Table K.1 — Arrhenius shift factors

Ageing temperature °C	a_T $E_a = 83 \text{ kJ/mol}, T_{(ref)} = 30 \text{ °C}$
30	1
40	2,865 1
50	7,690 8
60	19,456
70	46,626
80	106,34

The time-temperature superposition procedure can be applied to burst pressure and volume data independently. It is unlikely however that single superposed master curves will be obtained in such circumstances. Experience with some condoms has shown that time-temperature superposition plots of burst volume \times burst pressure result in a high degree of superposition. It is recommended therefore that superposition plots are constructed for burst pressure, burst volume and the product of pressure and volume ($p \cdot V$).

K.5.2 Procedure for constructing time-temperature superposition plots

Use shift factor values, a_T , from Table K.1 or calculate them from equation (K.1) for each ageing temperature using 30 °C as the reference temperature and 83 kJ/mol as the activation energy.

- a) For each set of ageing data, i.e. combination of time and temperature, calculate the transformed time by multiplying the time value by the shift factor, a_T , appropriate for that ageing temperature.
- b) Plot the mean air burst properties (pressure, volume and $p \cdot V$) against the appropriate transformed times. Each property should be plotted on a separate graph.
- c) To facilitate subsequent interpretation of the graphs, standard deviations can be included in the plots. Superposition plots showing the number of non-conforming condoms at each time point can also be informative.
- d) Estimate the shelf-life period from the graphs and knowledge of the variance or standard deviation of the sample populations. The shelf-life period is the time required at 30 °C for the burst pressure or burst volume to fall to the limiting value where the condoms will still be in compliance with the air burst requirements of 6.1. The following results are possible.
 - 1) A single master curve is obtained (most probably for $p \cdot V$) and the relevant values of the appropriate bursting properties can be simply read from the graphs at the end of the proposed shelf-life period.
 - 2) No master curve is obtained (the individual curves for each temperature do not superpose). In these circumstances it may still be possible to make predictions about the values of the burst properties — at the end of the proposed shelf-life period by investigating the trends in the curves. For example, the estimated value of the burst properties for each individual ageing temperature at the end of the proposed shelf life can be plotted against that ageing temperature. If these plots give consistent trends, then the burst properties at the proposed climatic temperature can be estimated by extrapolation. Where such methods are used to make predictions, a full justification is required to support the conclusions that have been reached.

K.5.3 Test of shelf-life estimates based upon Arrhenius shift factors

- a) Select a set of accelerated ageing conditions equivalent to the estimated shelf life at 30 °C. This is most easily achieved by using the Arrhenius shift factors to calculate the ageing times at the proposed ageing temperatures. The shift factors are based on an activation energy of 83 kJ/mol. The ageing conditions should be chosen with a view to replicating the mode of failure at 30 °C that is predicted by the stability study.
- b) Take samples of condoms from three lots in accordance with annex B. Condition the samples according to annex H at the selected ageing temperature for the selected time. Test the samples for compliance with the air burst requirements defined in 6.1.

The provisional shelf-life claim shall be up to that period, not to exceed five years, for which the condoms have complied with the requirements of 6.1.

Annex L (normative)

Testing for holes

L.1 General

This annex specifies two alternative methods of equal validity for testing natural rubber latex condoms for holes, the water leak test and the electrical test.

L.2 Water leak test

L.2.1 Principle

Filling of the condom with a specified volume of water and examining for visible water leakage through the wall of the suspended condom. In the absence of any leakage the condom is then rolled on coloured absorbent paper which is subsequently examined for signs of leakage of water from the condom.

L.2.2 Apparatus

L.2.2.1 Mounting equipment, suitable for mounting the condom at its open end, allowing it to be freely suspended, with a means of filling the condom with water while it is suspended. An example of a suitable mount is shown in Figure L.1.

L.2.2.2 Coloured absorbent paper.

L.2.2.3 Rolling device (optional), incorporating a smooth transparent plate. It can be placed at a fixed height of (30 ± 5) mm above and parallel to the absorbent paper, where its horizontal movement will roll the condom back and forth.

The plate, if used, shall turn the condom through at least one complete revolution, when it is moved through its travel.

L.2.2.4 Clamping device (optional), suitable for holding closed the twisted open end of a condom, and preventing it from leaking, without causing damage to the part to be rolled on absorbent paper. An example is a sprung paper clip.

L.2.3 Procedure

L.2.3.1 Move the condom inside the package such that it is away from the area where the package is to be torn. Tear the package and remove the condom.

In no circumstances use scissors or other sharp instruments to open the package.

Wear suitable gloves or finger cots while handling the condom.

L.2.3.2 Unroll the condom ensuring that it is not excessively stretched in any direction. If any hole or tear is noticed, that condom shall be deemed non-compliant and further testing of that condom shall be discontinued. (See rationale in annex P.)

L.2.3.3 Record condoms with other visible defects, namely: Broken, missing or severely distorted rim and permanent creases with adhesion of the film.

Dimensions in millimetres

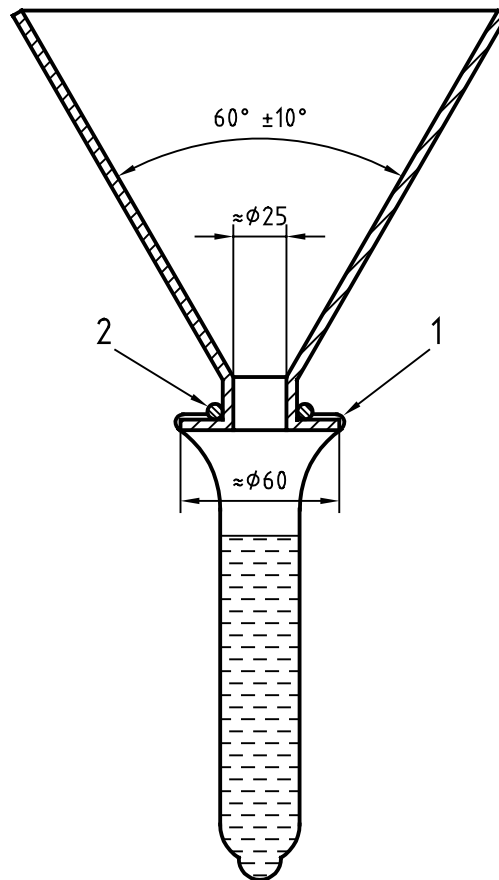
**Key**

- 1 Well-rounded edge
- 2 Rubber ring

Figure L.1 — Suitable mount

L.2.3.4 Fit the open end of the condom onto the mount so that the condom is suspended open end upwards.

L.2.3.5 Add (300 ± 10) cm³ of water at a temperature between 10 °C and 40 °C and make sure that the humidity in the ambient air does not condense on the outside of the condom. Inspect the condom for visible signs of leakage. Deem as failed any condom exhibiting visible signs of leakage from holes located more than 25 mm (determined to an accuracy of 1 mm) from the open end and discontinue the test. Holes found near the open end shall be marked, and measured after the condom is emptied to determine whether they are more than 25 mm from the open end.

If, because of lack of distension of the condom, it is not possible for 300 ml of water to be contained within the condom, permit the remainder of the water to form a pressure head within the filling system.

L.2.3.6 If there is no visible leakage through the condom after suspension, take hold of the condom by the closed end, and, if necessary, gently stretch the condom to displace the water from the open end. Seal the condom by twisting it at a point less than 25 mm from the open end, for approximately 1,5 revolutions, and remove it from the mount. Hold the end closed with one hand, or with a suitable clamping device (L.2.2.4).

L.2.3.7 Transfer the condom onto a dry sheet of absorbent paper, and roll the closed end around at least one revolution on the paper, keeping the hand applying the motion and pressure at a distance of 25 mm to 35 mm above the paper. Then lay the condom on the absorbent paper, with the axis of the cylinder thus formed parallel to the paper.

L.2.3.8 Roll the condom back and forth at least once for a distance at least equal to the circumference of the condom in its water-filled condition, using one of the two methods below.

a) Manual rolling

During rolling, spread the fingers of the hand so as to distribute the force on the condom as equally as possible. Maintain the hand at a distance of 25 mm to 35 mm above the absorbent paper. Move the hand with respect to the condom so that the condom as a whole is subjected to hand pressure and comes in contact with the absorbent paper.

b) Mechanically assisted rolling

Place the condom on the paper, and use the rolling device in L.2.2.3 to move the condom through at least one complete revolution.

The condom may be rolled through more than one revolution in order to verify whether or not there is leakage present. It is intended that the number of revolutions be small, and in no case greater than 10 over both pieces of absorbent paper.

NOTE Steps L.2.3.7 and L.2.3.8 may be conducted in any order. For lubricated condoms, the rolling may be done twice on two separate sheets of absorbent paper, to eliminate confusion between marks made by the lubricant and those made by the water.

L.2.3.9 Inspect the paper for any sign of leakage of water from the condom. Ignore any marks made by the lubricant. Holes found near the open end shall be marked, and their location measured after being emptied to verify that they are more than 25 mm from the open end. Condoms with holes more than 25 mm from the open end shall be deemed non-compliant.

L.3 Electrical test

L.3.1 Principle

The condoms are initially screened electrically to detect holes. A condom which has no holes acts as an insulator and allows no current to flow in an electrical circuit. A condom with a hole will allow a current to pass.

Condoms which fail the electrical test are then tested by rolling on coloured absorbent paper to confirm the presence or absence of a hole.

L.3.2 Apparatus

L.3.2.1 Electrical testing equipment, for example as shown in Figures L.2 and L.3.

The parameters are: voltage ($10 \pm 0,1$) V; resistance ($10 \pm 0,5$) k Ω ; accuracy of the voltmeter ± 3 mV.

L.3.2.2 Electrolyte solution, consisting of an aqueous sodium chloride solution [$\rho_{\text{NaCl}} = 10$ g/l] at (25 ± 5) °C, is recommended but a solution of suitable electrolyte with equivalent conductivity may be used as an alternative [e.g. $\rho_{\text{Na}_2\text{SO}_4} = (15,4 \pm 1,0)$ g/l].

L.3.3 Procedure

L.3.3.1 Move the condom inside the package such that it is away from the area where the package is to be torn. Tear the package and remove the condom.

In no circumstances use scissors or other sharp instruments to open the package.

Wear suitable gloves or finger cots while handling the condom.

L.3.3.2 Unroll the condom ensuring that it is not excessively stretched in any direction.

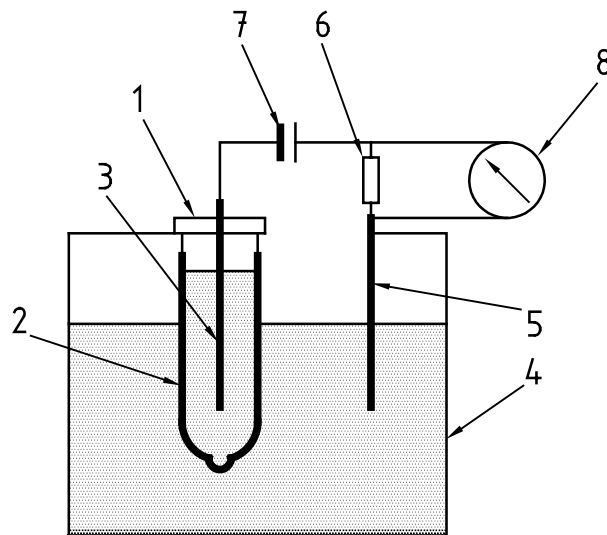
**Key**

- 1 Support (see Figure L.3)
- 2 Condom filled with electrolyte fixed on support
- 3 Electrode fixed to support
- 4 Container with electrolyte
- 5 Electrode
- 6 10 k Ω resistor
- 7 Stable 10 V voltage supply
- 8 Voltmeter

Figure L.2 — Diagram of equipment for electrical test

L.3.3.3 Examine the condom visually under normal or corrected vision. Deem as failed any condom which exhibits a visible hole or tear, and discontinue the test.

L.3.3.4 Record condoms with other visible defects, namely a broken, missing or severely distorted rim and permanent creases with adhesion of the film.

L.3.3.5 Fit the open end of the condom onto the mount (L.3.2.1) so that the condom is suspended open end upwards.

L.3.3.6 Add (200 ± 10) ml electrolyte (L.3.2.2) to the condom, inspect for visible electrolyte leakage. Deem as failed any condom which exhibits visible leakage. Submerge the non-leaking condom in a container also containing electrolyte such that all but at least 25 mm from the open end is submerged. Apply a 10 V stabilized continuous voltage source in series with a 10 k Ω high precision electrical resistance between the electrode in the container and the electrode inside the condom.

Measure the voltage at the resistor after (10 ± 2) s. Record the result.

If a voltage equal to or greater than 50 mV is recorded, empty the condom and subject the condom to the water test as described in L.2.3.4 to L.2.3.9, or test the condom according to L.3.3.7.

L.3.3.7 Add sufficient electrolyte/water to make the volume within the condom (300 ± 10) ml. Seal the open end of the condom by twisting the condom for approximately 1,5 revolutions and remove the condom from the mount. Remove the excess electrolyte by wiping the condom with a soft cloth or by gentle rolling on absorbent paper. Subject the condom to the water test as described in L.2.3.7 to L.2.3.9.

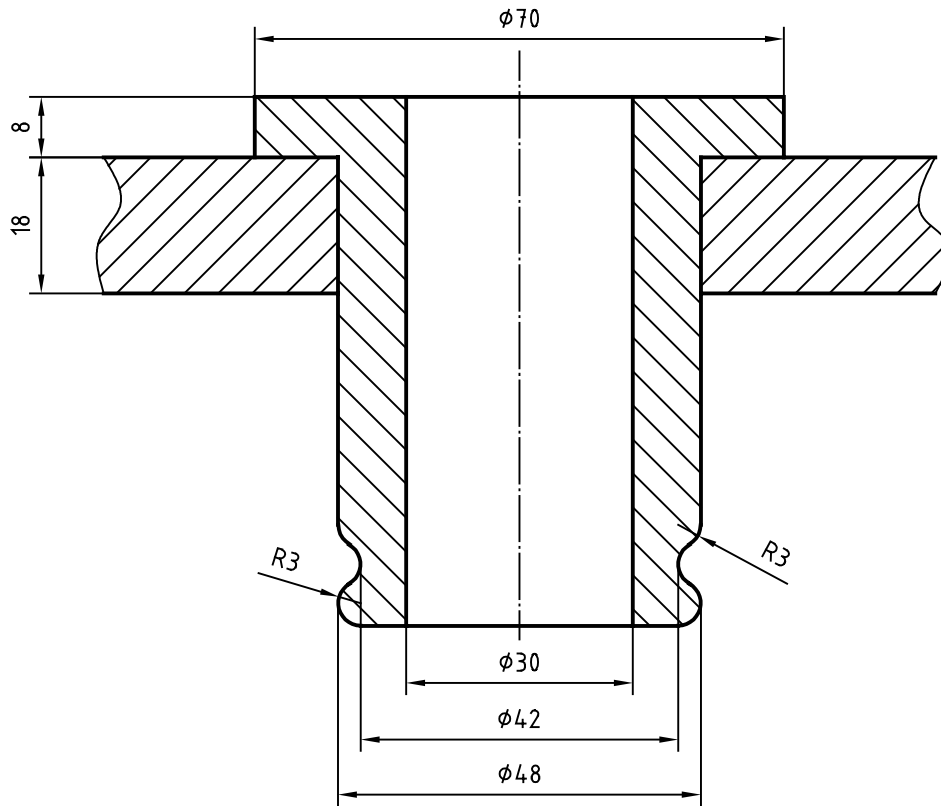

Figure L.3 — Examples of means of attaching the condom to the support

L.4 Expression of results

The test report shall include elements from annex N and the following particulars:

- the number of condoms exhibiting a visible hole or tear before mounting on the apparatus; the number of condoms exhibiting a voltage equal to or greater than 50 mV (in the case of the electrical test);
- the number of condoms with leaks observable on the apparatus, which when measured are located more than 25 mm from the open end (in the case of the visual test);
- the number of condoms which showed signs of leakage on rolling, which when measured are located more than 25 mm from the open end;
- the number of condoms with visible defects other than holes or tears, and the nature of the defects.

Annex M (normative)

Tests for package integrity

M.1 General

Package integrity refers to the possibility of breaches in sealed individual condom containers that may result in the leakage of lubricant. Such breaches will also cause the package to be permeable to oxygen. However, the test given in this annex cannot detect leakage due to microporosity or gas permeability of the materials used to construct the individual containers. Consequently, this test can be used only to detect leaks large enough to allow leakage of lubricant.

Several tests are under development. Pending conclusive validation that new tests provide greater sensitivity or consistency, package integrity shall be measured according to the following protocol using a vacuum level corresponding to (20 ± 5) kPa absolute pressure.

Some leaks may not be detected by this procedure. Positive pressure inside the condom container after the vacuum is drawn may force the lubricant, if present, to plug small leaks. The size of the leak that can be detected is dependent upon the lubricant and the nature of the packaging material.

M.2 Test method

M.2.1 Apparatus

M.2.1.1 Vacuum chamber, capable of withstanding approximately one atmosphere pressure differential, fitted with a vacuum pump, a vacuum gauge and the possibility to inspect the interior during the test. (See rationale in annex P.)

M.2.2 Reagent

M.2.2.1 Immersion fluid (water), treated with a wetting agent (such as dishwashing liquid).

M.2.3 Sampling

Use special inspection level S-3.

M.2.4 Test specimen

Condoms in their individual containers.

M.2.5 Conditioning

The test specimens and test fluid shall be at equilibrium with normal room temperature.

M.2.6 Procedure

Submerge the individual condom containers in water contained in a vessel within the vacuum chamber. The uppermost surface of the containers shall be covered by not less than 25 mm of water. If a dye is added to the water, leakage of water into the container will be easier to detect.

Two or more containers may be tested at the same time, provided that they are placed in such a manner that all parts of every container under test can be observed for leakage during the test.

Evacuate the chamber to an absolute pressure of (20 ± 5) kPa. As the vacuum increases, observe the condom containers for leakage in the form of a steady progression of bubbles. Isolated bubbles caused by entrapped air are not considered as leaks. Flexible packaging with little or no headspace cannot be reliably evaluated with this test method.

Hold the vacuum for 1 min. Release the vacuum, remove the lid, and examine the condom containers for the presence of water inside.

M.2.7 Interpretation of results

If there are bubbles indicating leaks in a condom container as the vacuum increases, or when held at specified vacuum, then the specimen fails the tests.

If the test fluid is visible inside a container, the container fails the test.

If there are no bubbles observed indicating leaks, and if no test fluid is visible inside a container, the container passes the test.

M.2.8 Test report

The test report shall include the elements of annex N and the following particulars:

- a) the numbers of containers with detected leaks from air-bubbles;
- b) the numbers of containers with detected leaks of fluid inside the container.

Annex N

(normative)

Test report

The test report shall contain at least the following information:

- a) name and address of the test laboratory;
- b) name and address of the client;
- c) identification of the test report;
- d) identification of the sample (sample size, lot number and lot size);
- e) origin of the sample, date of the sample's arrival to the laboratory and identity of the responsible party who has taken the sample;
- f) a reference to this International Standard and the relevant annexes;
- g) description of all deviations from this International Standard;
- h) results according to relevant annexes;
- i) measurement error, if available;
- j) date of the test report and the signature and title of the person(s) responsible for the report.

Normally it is recommended that condoms used in testing be destroyed after testing. Sometimes condoms need to be kept to demonstrate particular problems. Thus it is important that the condoms be marked or stored in such a way that unintentional use is prevented.

Annex O (informative)

Calibration of air inflation equipment for determination of burst volume and pressure

O.1 System check algorithm

Due to the diversity of equipment used by different laboratories, it is not practical to define all calibration and verification procedures.

The steps described in O.2 to O.10 and listed in Figure O.1, if performed in order, are an example of suitable system checks for verification, audit and calibration which apply to many systems. The algorithm may need to be adapted to suit individual equipment configurations. Some systems may benefit from the installation of additional equipment, such as tees, isolating valves or manual control switches, to facilitate system checking.

In-house calibrations should be done at appropriate intervals, or whenever there is a reason to doubt the reading on an instrument.

O.2 Clamp slip force check

This test ensures that the condom length does not vary significantly during inflation and consists of marking a condom as close as possible to the top of the collar, inflating the condom until it is near to burst, bursting it with a pin near the reservoir, and observing whether the mark has moved.

O.3 Inflation length check

This is a measurement, either on the test head or on the length-measuring mandrel, that verifies that 150 mm of condom is being inflated, i.e. that the length limiter is properly set, that the condom is not stretched by the clamping equipment, and that it is not being blown out of position before the clamp grips it.

O.4 Cuff leak check

This is a check that inflated cuffs do not leak air, especially into the condom. If the cuff and the air supply can be actuated separately, it is possible to check the cuff by turning on the air supply, isolating the cuff, and then observing it to see that it is still inflated after, say, 5 min.

O.5 Air supply leak check

This step checks that there are no leaks in the air supply system or the pressure-sensing system that would cause an error in the measured volume.

O.6 Pressure gauge calibration

Pressure gauges or transducers can be checked regularly against a reference meter, connected in parallel with the gauge or transducer. A convenient and accurate reference is a water-tube manometer. The whole range of pressures encountered should be checked, either by placing a variable constriction over the test head or by inflating a condom (or two, one over the other) in stages.

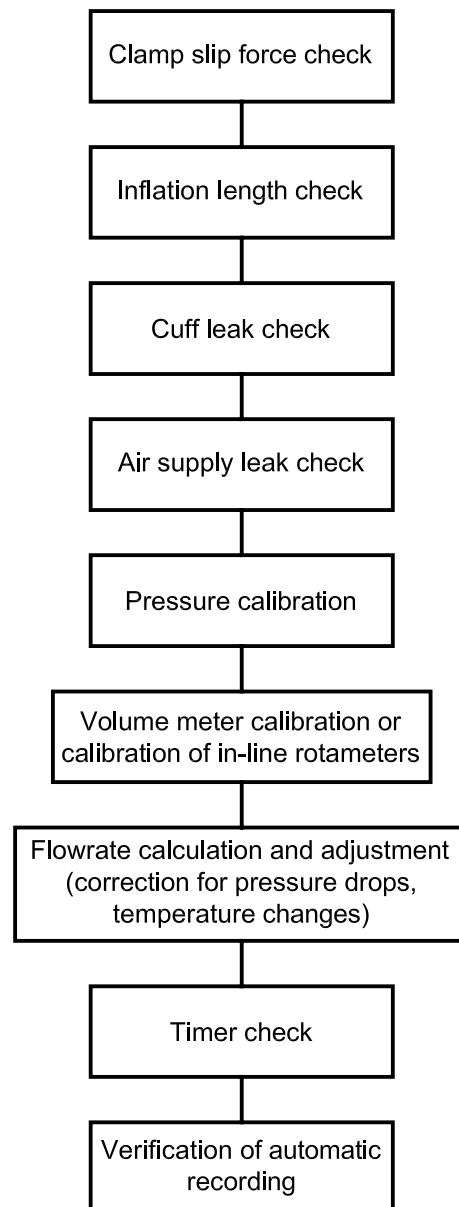

NOTE Some items, such as elimination of leaks, are a prerequisite to others, such as calibration of volume and pressure readings, but others, such as timer checking, inflation length and verification of automatic recording, can be done independently of most other checks.

Figure O.1 — List of periodic checks

O.7 Air flowrate adjustment and calibration

If the system relies on timing the inflation and multiplying by the flowrate, the flowrate needs to be known accurately; if, however, total volume is measured, it needs only to be within the stipulated range. It is advisable to set the flowrate around the centre of the allowable range, to allow for fluctuations due to ambient conditions.

Flowrate calibration is conveniently carried out using a suitable variable-area flowmeter (rotameter) calibrated against a certified instrument. Rotameters are simple in construction, having few moving parts, and much of the critical equipment inside the meter is directly visible to the user. Volume meters can also be used.

The calibrating meter should be attached directly to the condom test head, where the condoms are normally mounted. Suitable stands and connecting hoses (with minimal pressure drop) may be necessary. If there is no permanent in-line meter, it is important to verify that the connection of the meter does not alter the flowrate significantly.

Changes in ambient conditions may affect the flowrate slightly, and on systems that rely on elapse of time to burst, flowrate should be checked and recalculated twice daily, and whenever there are major weather changes.

O.8 In-line volume or flowrate meter calibration

For systems equipped with an in-line volume meter (for example, a diaphragm meter or a turbine meter), the meter's accuracy can be checked against the rotameter (or other reference meter) cited above. The test defines volume as the quantity of air delivered to the condom, and either it must thus be measured at the test head, or a correction must be made (using the ideal gas law) for any expansion between the volume meter and the test head. The pressure drop between the volume meter and the test head should be ascertained by a pressure gauge at the volume meter.

In-line rotameters, like calibrating rotameters, are governed by the rotameter equation. A correction must be made for the pressure and temperature under which the rotameter is operating, and for the expansion between the in-line meter and the test head.

O.9 Timer check

Stopwatches or electric timers should be checked against nationally certified timers (for example, telephone clocks or broadcast time signals).

O.10 Verification of automatic recording

On systems where results (of pressures, volumes or times) are recorded automatically using computers or other equipment, it is necessary to check that the quantities recorded are actually those current at the time of burst. This must be done for each test head in the system. The burst volume (or time, as appropriate to the system) and the burst pressure should be observed for five condoms on each head. The results should be compared with the automatically recorded values.

O.11 Important equations

If a gas experiences a drop in pressure as it flows, it will expand. The flowrate and the pressure are related by the ideal gas law:

$$p_1 \cdot q_1 = p_2 \cdot q_2 \tag{O.1}$$

where

p_1 and q_1 are the pressure and flowrate at point 1 in the system;

p_2 and q_2 are the pressure and volume at point 2.

The reading on a rotameter depends on the pressure and temperature of the gas flowing through it. If a rotameter is calibrated at pressure p_0 and temperature T_0 but the actual conditions where the measurement is being made are p_m and T_m then the true flowrate, Q , is related to the flowrate indicated, q , by the following equation:

$$Q = q \cdot \sqrt{\frac{p_0 \cdot T_m}{p_m \cdot T_0}} \tag{O.2}$$

NOTE All pressures in the above equation are absolute pressures.

Annex P (informative)

Rationale

P.1 General

With the exception of the tests for stability and shelf life described in clause 7, this International Standard does not require that a manufacturer perform any of the tests. Rather, the Quality System must assure that the products meet the requirements set in this International Standard when tested by a third party, using the specified test methods. In practice, most manufacturers test samples of their finished products by the methods in this International Standard or use other validated methods in order to ensure that the products meet the requirements given. The test methods can also be useful when manufacturers create their quality management systems.

Test methods intended for third party verification of the quality of isolated lots are included in this International Standard.

This International Standard introduces a requirement for manufacturers to estimate the shelf life of any new or modified product and to initiate real-time ageing studies before placing the product on the market. Provision is made through accelerated stability studies to allow manufacturers to introduce new products in a timely manner while ensuring that there is ongoing surveillance through the real-time stability studies to confirm shelf-life claims. Technical details on stability and shelf-life requirements are described in clause 7.

Certain elements of this International Standard (Introduction and clause 11) indicate requirements yet do not specify measurement parameters, limits or test method. These requirements shall be addressed by the manufacturer's quality system.

P.2 5.3.2 and 6.1

Measurements of width are made at two different locations on the condom. In 5.3.2 the width is measured to define size. This is important for the safety of the consumer, to avoid the condom slipping off the penis in use. For this reason the width is measured within 35 mm of the open end. In 6.1, the width is measured at the midpoint of the condom for use in determining the minimum bursting volume. The measurement is done at the midpoint to ensure that the most appropriate requirement for bursting volume is chosen. If the condom is parallel-sided, the value for width determined according to 5.3.2 may be used in 6.1.

The marking of 75 mm from the closed end, as required in 6.1, may be done at the time that the condom is placed on the mandrel.

P.3 6.3 Requirements for products proclaiming "extra strength"

In many countries some types of condom are described as "extra strong", "extra strength", "hyper-safe", etc. "Extra-strong" condoms are sometimes recommended for anal sex. To avoid this claim being made for regular condoms, this International Standard imposes an additional requirement on condoms claiming to be "extra strong".

The force at break, as measured by a tensile test, shall exceed 100 N, compared to ca. 70 N, which is a typical value for regular condoms. 100 N is an empirical value based on tests conducted on "extra strong" condoms available in the major markets. The value 2,0 kPa was also chosen in the same way to discriminate from "regular" condoms in conjunction with the tensile test.

The extra strength requirement in this International Standard typically indicates that the condom is thicker. Insufficient comparative clinical studies have been conducted to determine whether or not thicker condoms break less in use. "Extra strong" condoms may be perceived as being less sensitive and therefore less acceptable to some users. Nevertheless, other users prefer this type of product. Therefore, additional requirements have been added for

this type of product, including requirements for clinical evaluation of the performance or additional labelling information.

P.4 Clause 7

Tests for shelf life and stability are new requirements introduced in this edition. These tests should not be confused with the European Type examination, performed by a third party, which is a pre-market regulatory procedure. The tests in clause 7 shall be regarded as part of the manufacturer's pre-marketing approval system for new products. The real-time study is intended to validate any results obtained from accelerated ageing studies. The requirements in clause 7 are intended to avoid unnecessary testing and help the manufacturer to prepare one set of documentation for all markets.

Stability studies and shelf-life estimates shall be conducted at or referenced to 30 °C since studies have shown that this is the mean kinetic temperature of tropical climates and is therefore suitable for condoms intended to be distributed to any part of the world. ISO/TC 157 believes that since manufacturers may not be able to control the ultimate destination of their products, the most stringent requirements, i.e. tropical conditions, shall apply.

P.5 Clause 11

a) 11.1

The requirements relating to ink and the protection afforded to the condom by the containers and packages during transport, storage and opening shall be evaluated by the manufacturer on the basis of practical experience and consumer complaints and shall form a part of the manufacturers and/or distributors quality system. No specific test methods for packages, other than for package integrity in clause 10, are deemed necessary. For new designs of packages the manufacturer shall, on request, supply the regulatory authorities with a justification that the packages are adequate to ensure that the condoms meet the requirements in this standard after normal handling, transport and storage. It is assumed that the risk of damage to the condom during opening of the packages will be assessed during normal testing and will be reflected in the test results.

If condoms are supplied directly to consumers in individual containers then the individual container shall be regarded as a consumer package and shall meet all the labelling requirements.

b) 11.2.2 a), 11.2.3 d)

Depending on the regulatory system in the country where the condoms are marketed, action taken by a distributor such as marking (brand names), packaging or labelling may qualify him to be regarded as a manufacturer.

c) 11.2.2 c)

The format of the expiry date, month/year or year/month) does not matter as long as the requirements in the subclause are met. The intention of this subclause is to avoid any confusion because of different practices.

d) 11.2.3.1 d)

See 11.2.2.

e) 11.2.4 d)

The year of publication of the International Standard is not important if space is limited. The reason for stating the International Standard on the package is to indicate to the consumer that the condom meets high safety requirements in those markets where no regulations exist.

P.6 C.4 Precision and bias

Table P.1 is based on an interlaboratory study on the accuracy of lubricant recovery from condoms with two lubricants — silicone and polyethyleneglycol (PEG/N9) — tested by nine laboratories.

NOTE The number of materials does not meet the minimum requirements for determining precision prescribed in ASTM Practice E691.

In both cases 400 mg of lubricant was applied to the condoms. The difference (recovered minus applied) was analysed. The results of this study will not necessarily apply to other lubricant doses.

Table P.1 — Lubricant recovery

Lubricant type	Average difference (Lubricant recovered — Lubricant applied) mg	Standard deviation		Repeatability	Reproducibility
		s_r	s_R	r	R
Standard silicone	85	23	40	64	113
PEG/N9	83	20	37	55	104

The average difference observed between lubricant applied and lubricant recovered is given in the “Average difference” column of the table above. The figure is the bias of the method, that is, the method recovers 83 mg to 85 mg more “lubricant” than was applied.

s_r is the within-laboratory standard deviation of the average lubricant recovered;

s_R is the between-laboratory standard deviation of the average lubricant recovered;

r is the within-laboratory repeatability limit = $2,8 s_r$;

R is the between-laboratory reproducibility limit = $2,8 s_R$.

Since single test results were obtained, R represents the variability obtained between different laboratories on test specimens taken at random from a single quantity of homogeneous material.

The absolute difference between two single test results is expected to lie below R with a probability of 95 %.

P.7 D.3.2 — Removal of lubricants

An example of a procedure to remove lubricants is given below.

- a) Remove any lubricant or powder by washing with a suitable solvent such as propan-2-ol. Rinse the condom in a slurry of talc (fine grade) in a suitable solvent such as propan-2-ol (50 g/l). Dry the suspended specimen in a suitably ventilated space for at least 15 min.
- b) The closed end of the condom is removed to provide a suitably sized opening which allows free flow of air to dry the inside of the condom.
- c) Remove any excess talc by wiping.
- d) Allow the condom to dry thoroughly for at least 16 h at $(23 \pm 2) ^\circ\text{C}$, and $(50 \pm 5) \%$ relative humidity.

P.8 E.3.2

See P.7 for a procedure to remove lubricants.

P.9 Annex I

- a) I.1

Annex I is partly used in this International Standard for the verification of extra strength. The test method for elongation is informative maintained in this International Standard as there is a need to have standardized methods for purposes other than the requirements of this International Standard.

- b) I.3.4

See D.3.2 for a procedure to remove lubricants.

P.10 Annex L

a) L.2

Based on ASTM D 3078-94 [19].

b) L.2.3.2

A visible hole or a tear near the open end may cause the condom to slip or break. Visible holes or tears are judged over the full length of the condom including the 25 mm from the open end.

c) L.2.3.5

Depending on the relative humidity, the difference in temperature between the room and the water in the condom condensation may occur on the condom surface.

Bibliography

- [1] ISO/IEC Guide 7, *Guidelines for drafting of standards suitable for use for conformity assessment*
- [2] ISO 10993-1, *Biological evaluation of medical devices — Part 1: Evaluation and testing*
- [3] ISO 10993-10, *Biological evaluation of medical devices — Part 10: Tests for irritation and delayed-type hypersensitivity*
- [4] ISO 2230, *Rubber products — Guidelines for storage*
- [5] ISO 9000-1, *Quality management and quality assurance standards — Part 1: Guidelines for selection and use*
- [6] ISO 9001, *Quality management systems — Requirements*
- [7] ISO 9002, *Quality systems — Model for quality assurance in production, installation and servicing*
- [8] ISO 9004, *Quality management system — Guidelines for performance improvements*
- [9] ISO/TR 8550:1994, *Guide for the selection of an acceptance sampling system, scheme or plan for inspection of discrete items in lots*
- [10] EN 10002-2, *Metallic materials — Tensile testing — Part 2: Verification of the force measuring system of the tensile testing machines*
- [11] ISO 13485, *Quality systems — Medical devices — System requirements for regulatory purposes*
- [12] ISO 13488, *Quality systems — Medical devices — Particular requirements for the application of ISO 9002*
- [13] ISO 14971-1, *Medical devices — Application of risk management to medical devices*
- [14] *Contraception*, **53**, 1996, pp. 221-229, Package, lubricant and formulation are all important in resisting aging under sub-optimal conditions
- [15] ISO 11346, *Rubber, vulcanized or thermoplastic — Estimation of life-time and maximum temperature of use*
- [16] ISO 16037, *Rubber condoms for clinical trials — Measurement of physical properties*
- [17] ISO 14155, *Clinical investigation of medical devices*
- [18] ISO 16038, *Latex rubber condoms — Quality management — Guidance on use of ISO 4074*
- [19] ASTM D 3078-94, *Standard Test Method for Determination of Leaks in Flexible Packaging by Bubble Emission*. American Society For Testing And Materials, West Conshohocken, PA., USA. <http://www.astm.org/>.
- [20] *Drug Development and Industrial Pharmacy*, **24** (4), 1998, pp. 313-325, Extension of the International conference on harmonization tripartite guideline for stability testing of new drug substances and products to countries of climate zones III and IV
- [21] *Drug Development and Industrial Pharmacy*, **19** (20), 1993, pp. 2795-2830, Storage conditions for stability testing in the EC, Japan and USA
- [22] *Polymer Preprints*. **34** (2), 1993, p. 185, Washington DC. American Chemical Society. Extrapolating accelerated thermal aging results: a critical look at the Arrhenius method
- [23] BARKER, L.R. *J. Nat. Rubb. Res.*, **2** (4), 1987, pp. 210-213

- [24] BARKER, L.R. *J. Nat. Rubb. Res.*, **5** (4), 1990, pp. 266-274
- [25] MANDEL, J., *et al. J. Res. Nat. Bur. Stand.*, **63** C, No. 2, 1959
- [26] GRIMM, W., *Drug Dev. Ind. Pharm.*, **19** (20), 1993, pp. 2795-2830
- [27] PANNIKOTTU, A. and KARMARKAR, U. *Elastomer Service Life Prediction Symposium '99*, E.J. Thomas Hall, University of Akron, OH, USA

ISO 4074:2002(E)

ICS 11.200

Price based on 46 pages

© ISO 2002 – All rights reserved