

---

---

## Hexagon socket set screws with cone point

*Vis sans tête à six pans creux, à bout tronconique*

**PDF disclaimer**

This PDF file may contain embedded typefaces. In accordance with Adobe's licensing policy, this file may be printed or viewed but shall not be edited unless the typefaces which are embedded are licensed to and installed on the computer performing the editing. In downloading this file, parties accept therein the responsibility of not infringing Adobe's licensing policy. The ISO Central Secretariat accepts no liability in this area.

Adobe is a trademark of Adobe Systems Incorporated.

Details of the software products used to create this PDF file can be found in the General Info relative to the file; the PDF-creation parameters were optimized for printing. Every care has been taken to ensure that the file is suitable for use by ISO member bodies. In the unlikely event that a problem relating to it is found, please inform the Central Secretariat at the address given below.

© ISO 2003

All rights reserved. Unless otherwise specified, no part of this publication may be reproduced or utilized in any form or by any means, electronic or mechanical, including photocopying and microfilm, without permission in writing from either ISO at the address below or ISO's member body in the country of the requester.

ISO copyright office  
Case postale 56 • CH-1211 Geneva 20  
Tel. + 41 22 749 01 11  
Fax + 41 22 749 09 47  
E-mail [copyright@iso.org](mailto:copyright@iso.org)  
Web [www.iso.org](http://www.iso.org)

Published in Switzerland

## Foreword

ISO (the International Organization for Standardization) is a worldwide federation of national standards bodies (ISO member bodies). The work of preparing International Standards is normally carried out through ISO technical committees. Each member body interested in a subject for which a technical committee has been established has the right to be represented on that committee. International organizations, governmental and non-governmental, in liaison with ISO, also take part in the work. ISO collaborates closely with the International Electrotechnical Commission (IEC) on all matters of electrotechnical standardization.

International Standards are drafted in accordance with the rules given in the ISO/IEC Directives, Part 2.

The main task of technical committees is to prepare International Standards. Draft International Standards adopted by the technical committees are circulated to the member bodies for voting. Publication as an International Standard requires approval by at least 75 % of the member bodies casting a vote.

Attention is drawn to the possibility that some of the elements of this document may be the subject of patent rights. ISO shall not be held responsible for identifying any or all such patent rights.

ISO 4027 was prepared by Technical Committee ISO/TC 2, *Fasteners*.

This third edition cancels and replaces the second edition (ISO 4027:1993), which has been technically revised.

© ISO 2003. All rights reserved.



# Hexagon socket set screws with cone point

## 1 Scope

This International Standard specifies the characteristics of hexagon socket set screws with cone point and threads from M1,6 up to and including M24 and of product grade A.

If, in special cases, specifications other than those listed in this International Standard are required, they should be selected from existing International Standards, e.g. ISO 261, ISO 898-5, ISO 965-2, ISO 3506-3 and ISO 4759-1.

## 2 Normative references

The following referenced documents are indispensable for the application of this document. For dated references, only the edition cited applies. For undated references, the latest edition of the referenced document (including any amendments) applies.

ISO 225, *Fasteners — Bolts, screws, studs and nuts — Symbols and designations of dimensions*

ISO 261, *ISO general-purpose metric screw threads — General plan*

ISO 898-5, *Mechanical properties of fasteners made of carbon steel and alloy steel — Part 5: Set screws and similar threaded fasteners not under tensile stresses*

ISO 965-2, *ISO general purpose metric screw threads — Tolerances — Part 2: Limits of sizes for general purpose external and internal screw threads — Medium quality*

ISO 965-3, *ISO general purpose metric screw threads — Tolerances — Part 3: Deviations for constructional screw threads*

ISO 3269, *Fasteners — Acceptance inspection*

ISO 3506-3, *Mechanical properties of corrosion-resistant stainless-steel fasteners — Part 3: Set screws and similar fasteners not under tensile stress*

ISO 4042, *Fasteners — Electroplated coatings*

ISO 4759-1, *Tolerances for fasteners — Part 1: Bolts, screws, studs and nuts — Product grades A, B and C*

ISO 6157-1, *Fasteners — Surface discontinuities — Part 1: Bolts, screws and studs for general requirements*

ISO 8839, *Mechanical properties of fasteners — Bolts, screws, studs and nuts made of non-ferrous metals*

ISO 8992, *Fasteners — General requirements for bolts, screws, studs and nuts*

ISO 10683, *Fasteners — Non-electrolytically applied zinc flake coatings*

ISO 23429, *Gauging of hexagon sockets*

### 3 Dimensions

See Figure 1 and Table 1.

Symbols and designations of dimensions are specified in ISO 225.

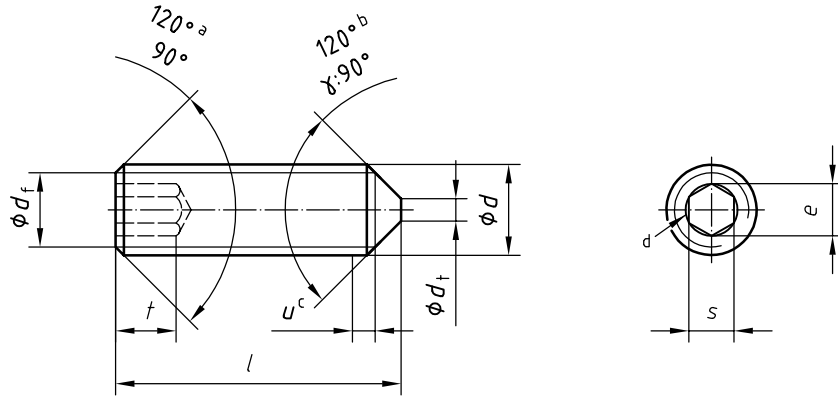

#### Permissible alternative form of socket

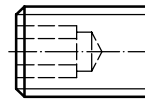

For broached sockets which are at the maximum limit of size, the overcut resulting from drilling shall not exceed 1/3 of the length of any flat of the socket which is  $e/2$ .

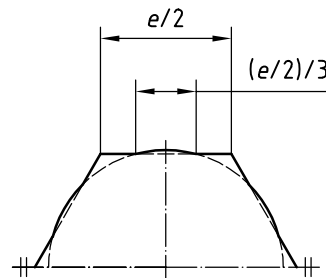

- a The  $120^\circ$  angle is a requirement for short-length screws of nominal length  $l$ , situated in the shaded areas in Table 1.
- b The angle  $\gamma$  applies only to the portion of the point situated below the root diameter of the thread, and shall be  $120^\circ$  for nominal lengths situated in the shaded areas in Table 1 and  $90^\circ$  for all other lengths.
- c Incomplete thread  $u < 2P$ .
- d A slight rounding or countersink at the mouth of the socket is permissible.

Figure 1

Table 1 — Dimensions

Dimensions in millimetres

Thread ( <i>d</i> )	M1,6	M2	M2,5	M3	M4	M5	M6	M8	M10	M12	M16	M20	M24			
<i>P</i> <sup>a</sup>	0,35	0,4	0,45	0,5	0,7	0,8	1	1,25	1,5	1,75	2	2,5	3			
<i>d</i> <sub>t</sub> max.	0,4	0,5	0,65	0,75	1	1,25	1,5	2	2,5	3	4	5	6			
<i>d</i> <sub>t</sub>	≈ Minor thread diameter															
<i>e</i> <sup>b, c</sup> min.	0,809	1,011	1,454	1,733	2,303	2,873	3,443	4,583	5,723	6,863	9,149	11,429	13,716			
<i>s</i> <sup>c</sup>	nom.	0,7	0,9	1,3	1,5	2	2,5	3	4	5	6	8	10	12		
	max.	0,724	0,913	1,300	1,58	2,08	2,58	3,08	4,095	5,14	6,14	8,175	10,175	12,212		
	min.	0,710	0,887	1,275	1,52	2,02	2,52	3,02	4,020	5,02	6,02	8,025	10,025	12,032		
<i>t</i>	min.	<sup>d</sup>	0,7	0,8	1,2	1,2	1,5	2	2	3	4	4,8	6,4	8	10	
		<sup>e</sup>	1,5	1,7	2	2	2,5	3	3,5	5	6	8	10	12	15	
<i>l</i>			Approximate mass, in kilograms per 1 000 pieces ( $\rho = 7,85 \text{ kg/dm}^3$ ) (for information only)													
nom.	min.	max.														
<b>2</b>	1,8	2,2	0,021	0,029												
<b>2,5</b>	2,3	2,7	0,025	0,037	0,063											
<b>3</b>	2,8	3,2	0,029	0,044	0,075	0,09										
<b>4</b>	3,76	4,24	0,037	0,059	0,1	0,13	0,18									
<b>5</b>	4,76	5,24	0,046	0,074	0,125	0,17	0,26	0,37								
<b>6</b>	5,76	6,24	0,054	0,089	0,15	0,21	0,34	0,49	0,69							
<b>8</b>	7,71	8,29	0,07	0,119	0,199	0,29	0,5	0,73	1,04	1,72						
<b>10</b>	9,71	10,29		0,148	0,249	0,37	0,66	0,97	1,39	2,35	3,41					
<b>12</b>	11,65	12,35			0,299	0,45	0,82	1,21	1,74	2,98	4,42	6,1				
<b>16</b>	15,65	16,35				0,61	1,14	1,69	2,44	4,24	6,43	8,9	14,9			
<b>20</b>	19,58	20,42					1,46	2,17	3,14	5,5	8,44	11,7	20,1	30,4		
<b>25</b>	24,58	25,42						2,77	4,02	7,08	10,9	15,3	26,6	40,7	54,2	
<b>30</b>	29,58	30,42							4,89	8,65	13,5	18,8	33,1	51	68,7	
<b>35</b>	34,5	35,5								10,2	16	22,3	39,6	61,3	83,2	
<b>40</b>	39,5	40,5								11,8	18,5	25,8	46,1	71,6	97,7	
<b>45</b>	44,5	45,5									21	29,3	52,6	81,9	112	
<b>50</b>	49,5	50,5									23,5	32,8	59,1	92,2	127	
<b>55</b>	54,4	55,6										36,3	65,6	103	141	
<b>60</b>	59,4	60,6										39,8	72,2	113	156	

NOTE Commercial lengths are those between the bold stepped lines.

<sup>a</sup> *P* is the pitch of the thread.

<sup>b</sup>  $e_{\text{min}} = 1,14 s_{\text{min}}$ .

<sup>c</sup> Combined gauging of socket dimensions *e* and *s*, see ISO 23429.

<sup>d</sup> For screws with nominal lengths in the shaded areas.

<sup>e</sup> For screws with nominal lengths below the shaded areas.

## 4 Requirements and reference International Standards

See Table 2.

**Table 2 — Specifications and reference International Standards**

Material		Steel	Stainless steel	Non-ferrous metal
<b>General requirements</b>	International Standard	ISO 8992		
	Tolerance	6g		
<b>Thread</b>	International Standards	ISO 261, ISO 965-2, ISO 965-3		
	Property class	45H	A1-12H, A2-21H, A3-21H, A4-21H, A5-21H	As agreed
<b>Mechanical properties</b>	International Standards	ISO 898-5	ISO 3506-3	ISO 8839
	Product grade	A		
<b>Tolerances</b>	International Standard	ISO 4759-1		
	<b>Finish</b>	As processed Requirements for electroplating are covered in ISO 4042. Requirements for non-electrolytically applied zinc flake coatings are covered in ISO 10683.	Plain	Plain Requirements for electroplating are covered in ISO 4042.
<b>Surface discontinuities</b>		Limits for surface discontinuities are covered in ISO 6157-1.	—	—
<b>Acceptability</b>		For acceptance procedure, see ISO 3269.		

## 5 Designation

EXAMPLE A hexagon socket set screw with cone point, thread M6, nominal length  $l = 12$  mm and of property class 45H, is designated as follows:

**Hexagon socket set screw ISO 4027 - M6×12 - 45H**





---

---

**ICS 21.060.10**

Price based on 4 pages