

INTERNATIONAL STANDARD

ISO
4023

Third edition
1991-09-15

Rubber hoses for steam — Test methods

Tuyaux en caoutchouc pour la vapeur — Méthodes d'essai



Reference number
ISO 4023:1991(E)

ISO 4023:1991(E)**Foreword**

ISO (the International Organization for Standardization) is a worldwide federation of national standards bodies (ISO member bodies). The work of preparing International Standards is normally carried out through ISO technical committees. Each member body interested in a subject for which a technical committee has been established has the right to be represented on that committee. International organizations, governmental and non-governmental, in liaison with ISO, also take part in the work. ISO collaborates closely with the International Electrotechnical Commission (IEC) on all matters of electrotechnical standardization.

Draft International Standards adopted by the technical committees are circulated to the member bodies for voting. Publication as an International Standard requires approval by at least 75 % of the member bodies casting a vote.

International Standard ISO 4023 was prepared by Technical Committee ISO/TC 45, *Rubber and rubber products*, Sub-Committee SC 1, *Hoses (rubber and plastics)*.

This third edition cancels and replaces the second edition (ISO 4023:1981), of which it constitutes a technical revision.

© ISO 1991

All rights reserved. No part of this publication may be reproduced or utilized in any form or by any means, electronic or mechanical, including photocopying and microfilm, without permission in writing from the publisher.

International Organization for Standardization
Case Postale 56 • CH-1211 Genève 20 • Switzerland

Printed in Switzerland

Rubber hoses for steam — Test methods

1 Scope

This International Standard specifies test methods in which the bore of a rubber hose test piece is exposed to saturated steam, so simulating service conditions.

Four methods are specified, namely:

- Method A: Vertical rack method
- Method B: Horizontal rack method
- Method C: Flexing test, vertical arrangement
- Method D: Flexing test, horizontal arrangement

CAUTION — All necessary safety devices shall be provided to ensure safe working conditions for the operators.

2 Method A: Vertical rack method

2.1 Principle

A length of hose is held in a fixed vertical position and saturated steam is passed through it.

NOTE 1 The temperature or pressure of the steam and the time of exposure should be stated in the relevant hose

specification. The relevant hose specification should also state which, if any, physical properties are to be checked for hose deterioration as well as the permitted changes in these properties. Properties commonly specified are bursting strength, tensile strength and elongation at break of the lining and/or cover and adhesion between layers. Visually assessed test criteria may also be specified, for example rupture of reinforcement, cracking of cover to a specified depth and pitting or blistering of the lining. Sometimes the time of exposure until the hose fails may be specified as the test criterion.

2.2 Apparatus (see figure 1)

Two fixed horizontal steam manifolds having suitable connections for attaching test pieces are placed one above the other at such a distance that the test pieces will just fit between the connections in a vertical position without distortion. Dry saturated steam at the required pressure is supplied to the test pieces through the upper manifold, which is equipped with a pressure-regulating valve, a recording gauge and suitable indicating gauge(s). The lower manifold is connected to a steam trap. Shut-off valves are provided at each opening in each manifold.

Should the apparatus be confined within an enclosure as a safety precaution, such an enclosure shall be so designed that the ambient temperature measured 25 mm from the outer surface of the hose is not greater than 11 °C above room temperature.

Dimensions in millimetres

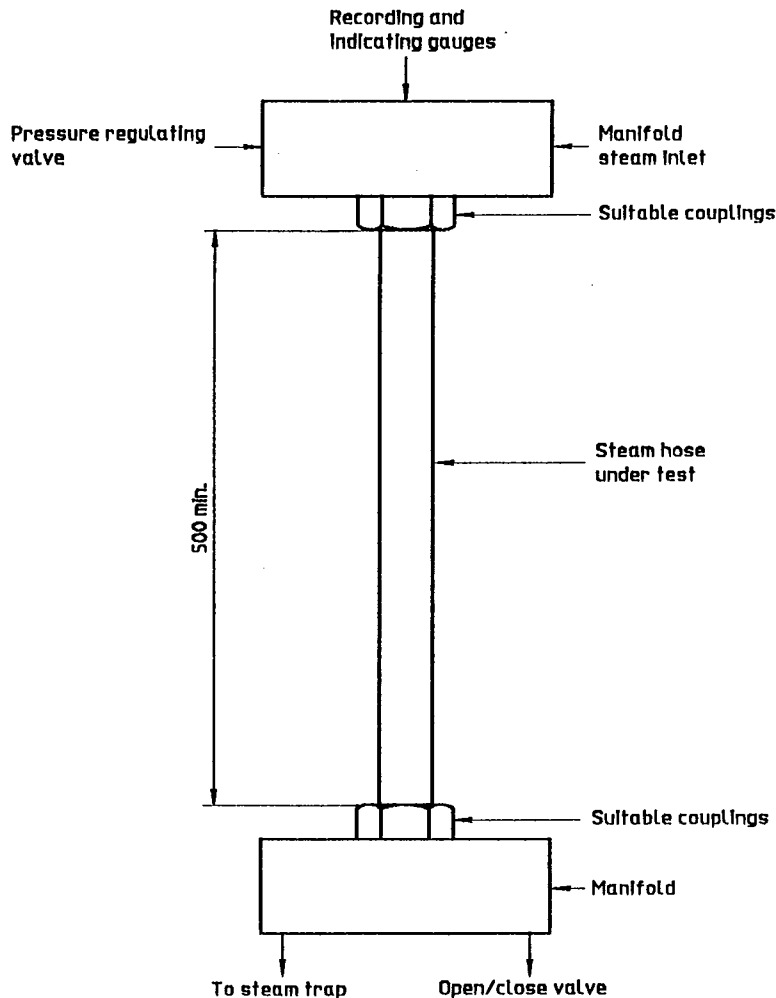

Figure 1 — Schematic diagram of arrangement for vertical steam rack test (method A)

2.3 Test piece

The test piece shall be a sample of hose, not less than 500 mm in length, and of a length sufficient to allow coupling removal after the steam test and re-coupling the hose with an appropriate coupling for a burst test.

2.4 Procedure

Mount the test piece in the apparatus and subject it to the internal steam conditions specified. After ex-

posure for the specified time, release the pressure in the test piece, remove it from the apparatus, allow it to cool and hold it under atmospheric conditions for not less than 16 h and not more than 100 h.

After this time, examine the test piece visually and carry out the physical determinations specified; at the same time, determine the same properties on a length of the hose which has not been exposed. If so specified, the exposure shall be continued until the hose fails, as indicated by the specified criteria, and the time to failure noted.

2.5 Test report

The test report shall include the following particulars:

- a) a full description of the hose tested;
- b) a reference to this test method, i.e. ISO 4023, method A;
- c) a reference to the relevant specification in which the test criteria are given or details of such criteria;
- d) the visual assessment of the test piece after testing;
- e) the results of the physical tests specified in the relevant specification;
- f) any other expression of results required by the relevant specification;
- g) any special observations.

3 Method B: Horizontal rack method

3.1 Principle

A length of hose is held in a horizontal position in such a manner that it sags, enabling condensate to collect in part of it.

NOTES

2 The temperature or pressure of the steam and the time of exposure should be stated in the relevant hose specification. The extent to which changes in appearance and physical properties as a result of exposure are permitted should be stated in the relevant hose specification (see also 2.1, note 1).

3 This test is usually used to measure the tendency for the lining to blister or "chunk" out ("popcorning"), i.e. for portions of the lining to fracture and become detached.

3.2 Apparatus (see figure 2)

Two fixed horizontal steam manifolds having suitable connections for attaching test pieces are placed parallel to each other and in the same horizontal plane approximately 1 m from each other. Dry saturated steam at the required pressure is supplied to the test piece through one manifold, which is equipped with a pressure-regulating valve, a recording gauge and a suitable indicating gauge. The other manifold is connected to a steam trap. Shut-off valves are provided at each opening in each manifold.

Should the apparatus be confined within an enclosure as a safety precaution, such an enclosure shall be so designed that the ambient temperature measured 25 mm from the outer surface of the hose is not greater than 11 °C above room temperature.

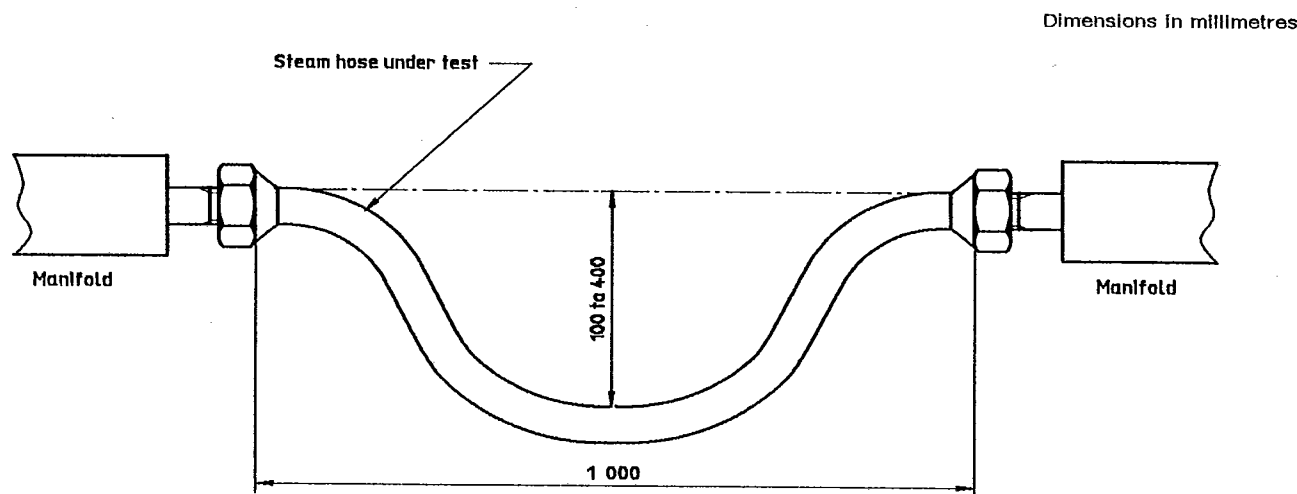

Figure 2 — Schematic diagram of arrangement for horizontal steam rack test (method B)

ISO 4023:1991(E)**3.3 Test piece**

The test piece shall be a sample of hose of suitable length to conform to figure 2.

3.4 Procedure

Mount the test piece in the apparatus so that there is a sag in the hose of 100 mm to 400 mm below the level of the hose at the manifolds. Subject the hose to the internal steam conditions specified. After 20 h, exhaust the hose within a time of 1 min or less, and allow the hose to cool to room temperature for 4 h. Repeat this cycle during the specified period or until failure occurs.

After exposure for the specified time, release the pressure in the test piece, remove it from the apparatus, allow it to cool, and hold it under atmospheric conditions for not less than 16 h and not more than 100 h.

After this time, examine the test piece visually and carry out the physical determinations specified; at the same time, determine the same properties on a length of the hose which has not been exposed. If so specified, the exposure shall be continued until the hose fails, as indicated by the specified criteria, and the time to failure noted.

3.5 Test report

The test report shall include the following particulars:

- a) a full description of the hose tested;
- b) a reference to this test method, i.e. ISO 4023, method B.
- c) a reference to the relevant specification in which the test criteria are given or details of such criteria;
- d) the visual assessment of the test piece after testing;

- e) the results of the physical tests specified in the relevant specification;
- f) any other expression of results required by the relevant specification;
- g) any special observations.

4 Method C: Flexing test, vertical arrangement**4.1 Principle**

A length of hose in a vertical configuration is repeatedly flexed whilst saturated steam is passed through it.

This test is normally run for a specified number of hours, during which there shall be no failure. The hose may then be visually examined or tested for compliance with specified conditions.

NOTE 4 The temperature or pressure of the steam and the time of exposure should be stated in the relevant hose specification. The extent to which changes in appearance and physical properties as a result of exposure are permitted should be stated in the relevant hose specification (see also 2.1, note 1).

4.2 Apparatus (see figure 3)

Two horizontal steam manifolds having suitable connections for attaching test pieces are spaced one above the other, mounted so that one of the manifolds is capable of moving vertically a distance of 315 mm during testing. Dry saturated steam at the required pressure is supplied to the specimens through the upper manifold, which is equipped with a pressure-regulating valve, a recording gauge and suitable indicating gauges. The lower manifold is connected to a steam trap. Shut-off valves are provided at each opening in each manifold.

Should the apparatus be confined within an enclosure as a safety precaution, such an enclosure shall be so designed that the ambient temperature measured 25 mm from the outer surface of the hose is not greater than 11 °C above room temperature.

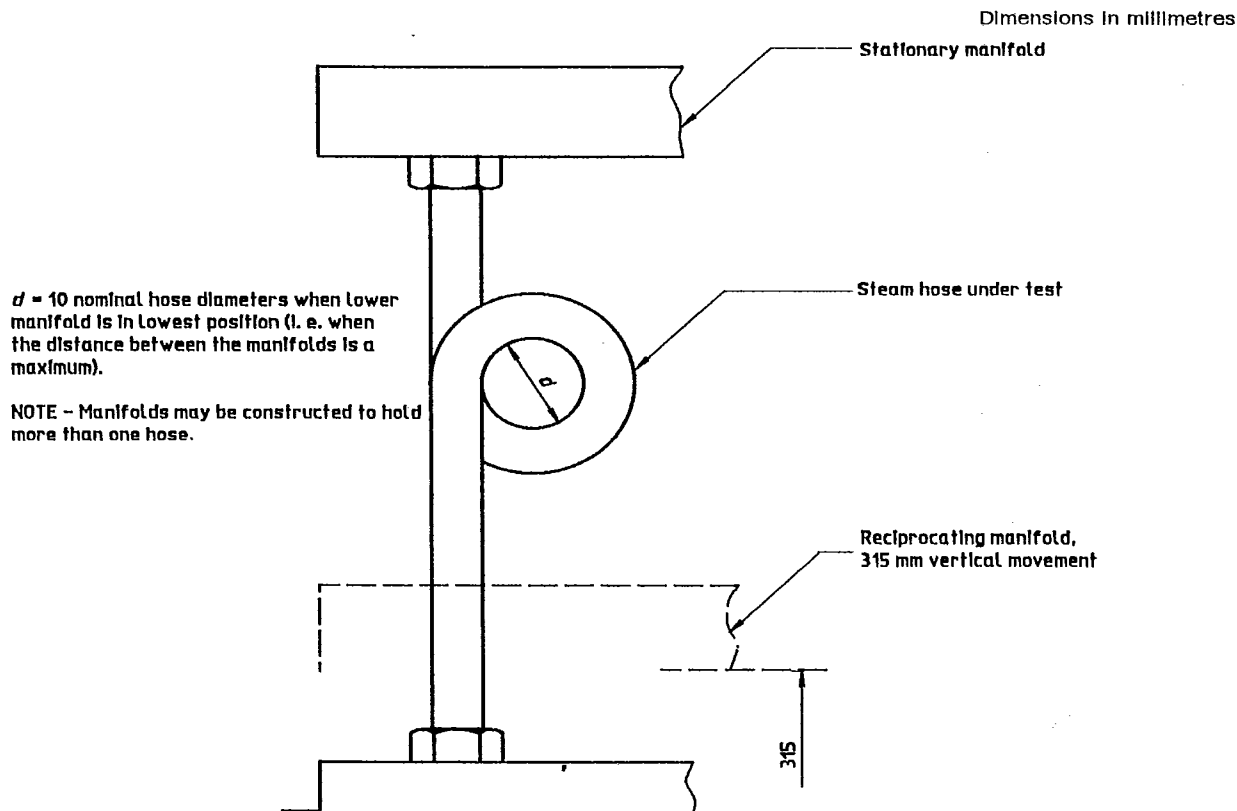

Figure 3 — Schematic diagram of arrangement for vertical flexing test (method C)

4.3 Test piece

The test piece shall be a piece of the hose sample cut to such a length that it will form a loop with an inside diameter (d in figure 3) 10 times the hose inside diameter when disposed between the manifolds at their maximum distance apart.

4.4 Procedure

Mount the test piece between the upper and lower manifolds in such a way that a loop is formed with an inside diameter 10 times the hose inside diameter with the manifolds at their maximum distance from each other. Apply steam at the required pressure continuously for the time specified. During this period of exposure, move one of the manifolds up and down on a 315 mm stroke to flex the test piece at a rate of 0,1 Hz. If necessary, the upper part of the loop may be supported by means of a suspension wire or cord.

After exposure for the specified time, release the pressure in the test piece, remove it from the apparatus, allow it to cool, and hold it under atmospheric

conditions for not less than 16 h and not more than 100 h.

After this time, examine the test piece visually and carry out the physical determinations specified; at the same time, determine the same properties on a length of the hose which has not been exposed. If so specified, the exposure shall be continued until the hose fails as indicated by the specified criteria, and the time to failure noted.

4.5 Test report

The test report shall include the following particulars:

- a) a full description of the hose tested;
- b) a reference to this test method, i.e. ISO 4023, method C.
- c) a reference to the relevant specification in which the test criteria are given or details of such criteria;
- d) the visual assessment of the test piece after testing;

ISO 4023:1991(E)

- e) the results of the physical tests specified in the relevant specification;
- f) any other expression of results required by the relevant specification;
- g) any special observations.

5 Method D: Flexing test, horizontal arrangement

5.1 Principle

A length of hose in a horizontal configuration is used for conveying saturated steam while being subjected to alternate flexing during a predetermined cycle.

The maximum bore size of hose which can be tested is 50 mm.

The hose is subjected to flexing, alternating with resting in a horizontal position, according to a timed cycle. The position is selected to evaluate the service performance of a hose in experimental conditions closely simulating regular industrial service conditions. Such a position causes three bends in reverse directions:

- first bend, in the area of the supply fitting;
- second bend, at the bottom part of the loop;
- third bend, in the area of the outlet fitting.

The reverse bends check the performance of the whole construction of the hose. From both the hori-

zontal position and the bottom bend, it can be inferred that condensed water is occasionally present which permits the testing of the hose in regular industrial service conditions.

The testing equipment allows the hose to take freely the bending permitted by its construction; from the measurements of the bending radii specified during the test, it is possible to evaluate the flexibility retained or the gradual degradation of the hose during the test.

NOTE 5 The temperature or pressure of the steam and the time of exposure should be stated in the relevant hose specification. The extent to which changes in appearance and physical properties as a result of exposure are permitted should be stated in the relevant hose specification (see also 2.1, note 1).

5.2 Apparatus (see figure 4)

The apparatus is designed so that it is possible to install one or several hoses using one steam supply line. The equipment may be used only for hoses not larger than 50 mm in diameter.

One end is stationary; the other end has an automatically timed reciprocating horizontal movement. The adjustable travel makes it possible to adjust the minimum bending radius at the start of the test as required.

During the test, the steam supply is kept constant and the supply circuit, properly drained, is controlled through a pressure recorder.

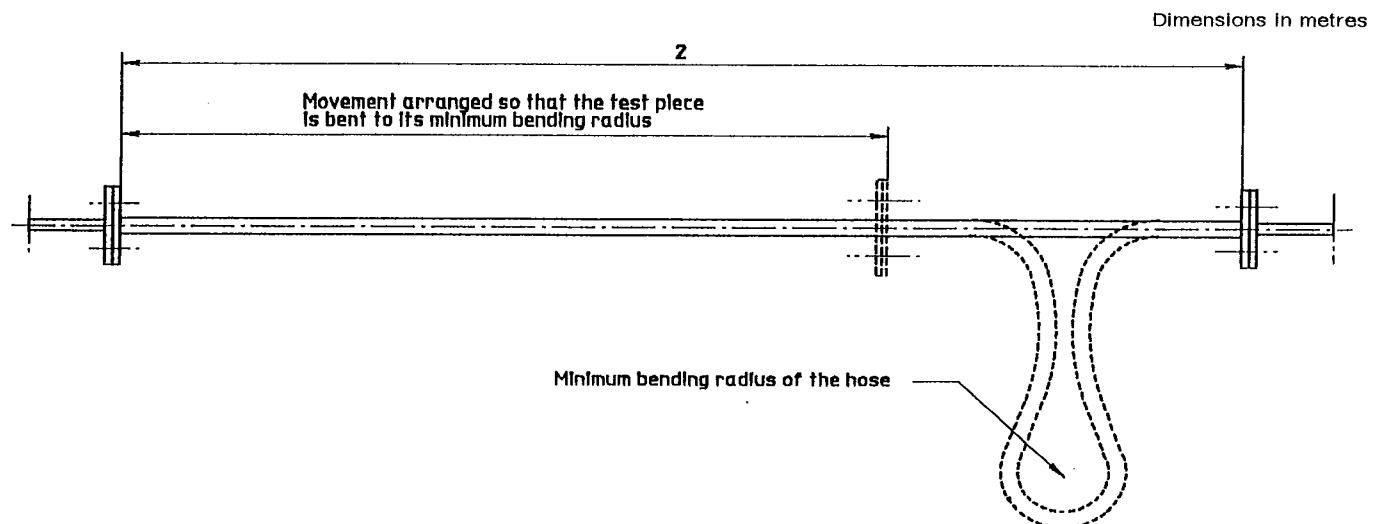

Figure 4 — Schematic diagram of arrangement for horizontal flexing test (method D)

5.3 Test piece

The test piece shall be 2 m in length for all bore sizes.

5.4 Procedure

Mount the test piece in the apparatus and adjust the horizontal movement so that the test piece is bent to its minimum bending radius.

The length of cycle shall normally be 4 h unless otherwise specified in the hose specification, made up as follows:

- Static horizontal position 3 h 15 min
- Flexing at 0,33 Hz 0 h 45 min

Measure the minimum bending radius on the original test piece and check the value once per cycle during the test.

After exposure for the specified time, release the pressure in the test piece, remove it from the apparatus, allow it to cool and hold it under atmospheric conditions for not less than 16 h and not more than 100 h.

After this time, examine the test piece visually and carry out any physical determinations specified; at the same time, determine the same properties on a

length of hose which has not been exposed. If so specified, the exposure shall be continued until the hose fails, as indicated by the specified criteria, and the time to failure noted.

5.5 Test report

The test report shall include the following particulars:

- a) a full description of the hose tested;
- b) a reference to this test method, i.e. ISO 4023, method D.
- c) a reference to the relevant specification in which the test criteria are given or details of such criteria;
- d) the visual assessment of the test piece after testing;
- e) the results of the physical tests specified in the relevant specification;
- f) any other expression of results required by the relevant specification;
- g) any special observations.



ISO 4023:1991(E)

UDC 621.643.3.023-036.4:620.162

Descriptors: rubber hoses, steam hoses, life (durability), tests.

Price based on 7 pages
