

INTERNATIONAL STANDARD

ISO 3999

Second edition
2004-12-15

Radiation protection — Apparatus for industrial gamma radiography — Specifications for performance, design and tests

*Radioprotection — Appareils pour radiographie gamma industrielle —
Spécifications de performance, de conception et d'essais*



Reference number
ISO 3999:2004(E)

© ISO 2004

PDF disclaimer

This PDF file may contain embedded typefaces. In accordance with Adobe's licensing policy, this file may be printed or viewed but shall not be edited unless the typefaces which are embedded are licensed to and installed on the computer performing the editing. In downloading this file, parties accept therein the responsibility of not infringing Adobe's licensing policy. The ISO Central Secretariat accepts no liability in this area.

Adobe is a trademark of Adobe Systems Incorporated.

Details of the software products used to create this PDF file can be found in the General Info relative to the file; the PDF-creation parameters were optimized for printing. Every care has been taken to ensure that the file is suitable for use by ISO member bodies. In the unlikely event that a problem relating to it is found, please inform the Central Secretariat at the address given below.

© ISO 2004

All rights reserved. Unless otherwise specified, no part of this publication may be reproduced or utilized in any form or by any means, electronic or mechanical, including photocopying and microfilm, without permission in writing from either ISO at the address below or ISO's member body in the country of the requester.

ISO copyright office
Case postale 56 • CH-1211 Geneva 20
Tel. + 41 22 749 01 11
Fax + 41 22 749 09 47
E-mail copyright@iso.org
Web www.iso.org

Published in Switzerland

Contents

Page

Foreword.....	iv
1 Scope	1
2 Normative references	1
3 Terms and definitions	2
4 Classification	4
4.1 Classification of exposure containers according to the location of the source assembly when the apparatus is in the working position	4
4.2 Classification of exposure containers according to their mobility	5
5 Specifications	5
5.1 General design requirements	5
5.2 Sealed sources	6
5.3 Ambient equivalent dose-rate limits in the vicinity of exposure containers	6
5.4 Safety devices	7
5.5 Handling facilities	8
5.6 Source-assembly security	8
5.7 Remote-control security	8
5.8 Resistance to normal conditions of service	9
6 Tests	12
6.1 Performance of the tests	12
6.2 Endurance test	12
6.3 Projection-resistance test	13
6.4 Tests for the exposure container	14
6.5 Tensile test for source assembly	18
6.6 Tests for remote control	19
6.7 Tests for projection sheaths and exposure heads (see 5.8.7)	20
7 Marking	22
7.1 Exposure container	22
7.2 Source holder or source assembly	22
8 Identification of the sealed source in the exposure container	22
9 Accompanying documents	22
9.1 Description and technical characteristics of the apparatus	23
9.2 Certificates of the manufacturer	24
9.3 Instructions for use	24
9.4 Inspection, maintenance and repair procedures	24
9.5 Instructions for disposal	25
10 Supplementary documents for the test laboratories to conduct the conformity study	25
11 Quality-assurance programme	25
Bibliography	32

Foreword

ISO (the International Organization for Standardization) is a worldwide federation of national standards bodies (ISO member bodies). The work of preparing International Standards is normally carried out through ISO technical committees. Each member body interested in a subject for which a technical committee has been established has the right to be represented on that committee. International organizations, governmental and non-governmental, in liaison with ISO, also take part in the work. ISO collaborates closely with the International Electrotechnical Commission (IEC) on all matters of electrotechnical standardization.

International Standards are drafted in accordance with the rules given in the ISO/IEC Directives, Part 2.

The main task of technical committees is to prepare International Standards. Draft International Standards adopted by the technical committees are circulated to the member bodies for voting. Publication as an International Standard requires approval by at least 75 % of the member bodies casting a vote.

Attention is drawn to the possibility that some of the elements of this document may be the subject of patent rights. ISO shall not be held responsible for identifying any or all such patent rights.

ISO 3999 was prepared by Technical Committee ISO/TC 85, *Nuclear energy*, Subcommittee SC 2, *Radiation protection*.

This second edition cancels and replaces ISO 3999-1:2000, of which it constitutes a minor revision.

Radiation protection — Apparatus for industrial gamma radiography — Specifications for performance, design and tests

1 Scope

This International Standard specifies the performance, design and test requirements of apparatus for gamma radiography with portable, mobile and fixed exposure containers of the various categories defined in Clause 4.

It applies to apparatus designed to allow the controlled use of gamma radiation emitted by a sealed radioactive source for industrial radiography purposes, in order that persons will be safeguarded when the apparatus is used in conformity with the regulations in force regarding radiation protection.

It is emphasised, however, that so far as transport of apparatus and sealed radioactive source is concerned, compliance with this International Standard is no substitute for satisfying the requirements of relevant international transport regulations (IAEA Regulations for the safe transport of radioactive materials: IAEA-STI-PUB 998, Safety Standards Series No. ST-1 and No. ST-2, and/or the relevant national transport regulations).

The operational use of apparatus for industrial gamma radiography is not covered by this International Standard. Users of this equipment shall comply with national regulations and codes of practice.

2 Normative references

The following referenced documents are indispensable for the application of this document. For dated references, only the edition cited applies. For undated references, the latest edition of the referenced document (including any amendment) applies.

ISO 361, *Basic ionizing radiation symbol*

ISO 2919:1999, *Radiation protection — Sealed radioactive sources — General requirements and classification*

ISO 7503-1, *Evaluation of surface contamination — Part 1: Beta-emitters (maximum beta energy greater than 0,15 MeV) and alpha-emitters*

IAEA-STI-PUB 998 (Safety Standards Series No. ST-1):1996, *Regulations for the safe transport of radioactive material*

IAEA-STI-PUB 998 (Safety Standards Series No. ST-2):1996, *Advisory Material for the IAEA Regulations for the safe Transport of Radioactive Material Safety Guide*

IEC 60068-2-6, *Environmental testing — Part 2: Tests — Test Fc: Vibration (sinusoidal)*

IEC 60068-2-47, *Environmental testing — Part 2-47: Test methods — Mounting of components, equipment and other articles for vibration, impact and similar dynamic tests*

IEC 60846, *Radiation protection instrumentation — Ambient and/or directional dose equivalent (rate) meters and/or monitors for beta, X and gamma radiation*

IEC 61000-6-1, *Electromagnetic compatibility (EMC) — Part 6: Generic standards — Section 1: Immunity for residential, commercial and light-industrial environments*

IEC 61000-6-2, *Electromagnetic compatibility (EMC) — Part 6: Generic standards — Section 2: Immunity for industrial environments*

IEC 61000-6-4, *Electromagnetic compatibility (EMC) — Part 6: Generic standards — Section 4: Emission standard for industrial environments*

3 Terms and definitions

For the purposes of this document, the following terms and definitions apply. Certain terms are illustrated in Figures 1 to 5 which, however, do not purport to illustrate typical or preferred designs.

3.1

ambient equivalent dose rate

dose rate measured as an average over the sensitive volume of the detector

NOTE 1 Measurements of the ambient equivalent dose rate shall be made at 1 m from the surface and additionally at the surface of the exposure container or at 50 mm from the surface.

NOTE 2 The limits are given in 5.3. The maximum cross-sectional areas of the detectors to be used are given in 6.4.1.2.

cf. ICRU 51.

3.2

apparatus for industrial gamma radiography

apparatus including an exposure container, a source assembly, and as applicable, a remote control, a projection sheath, an exposure head, and accessories designed to enable radiation emitted by a sealed radioactive source to be used for industrial radiography purposes

NOTE In the following text, an “apparatus for industrial gamma radiography” can be used for any means of non-destructive testing using gamma radiation.

3.3

automatic securing mechanism

automatically activated mechanical device designed to restrict the source assembly to the secured position

3.4

beam limiter

shielding device located at the working position designed to reduce the radiation dose rate in directions other than the directions intended for use

NOTE The beam limiter may be designed to be used in conjunction with an exposure head or may incorporate an exposure head as an integral part of the device.

3.5

control cable

cable or other mechanical means used to project and retract the source assembly out from and into the exposure container by means of remote control

NOTE The control cable includes the means of attachment to the source holder.

3.6

control-cable sheath

rigid or flexible tube for guiding the control cable from the remote control to the exposure container and for providing physical protection to the control cable

NOTE The control-cable sheath includes the necessary connection(s) for attachment to the exposure container and to the remote control.

3.7

exposure container

shield, in the form of a container, designed to allow the controlled use of gamma radiation and employing a source assembly

3.8

exposure head

device which locates the sealed source included in the source assembly, in the selected working position, and prevents the source assembly from projecting out of the projection sheath

3.9

lock

mechanical device with a key used to lock or unlock the exposure container

3.10

locked position

condition of the exposure container and source assembly in the secured and locked position

3.11

maximum rating

maximum activity, expressed as in 7.1.3, of a sealed source specified for a given radionuclide by the manufacturer, marked on the exposure container and not to be exceeded if the apparatus is to conform to this International Standard

3.12

projection sheath

flexible or rigid tube for guiding the source assembly from the exposure container to the working position and having the necessary connections for attachment to the exposure container and to the exposure head, or including the exposure head itself

3.13

remote control

device enabling the source assembly to be moved to and from a working position by operation from a distance away from the exposure container

NOTE The remote control includes the control mechanism and, where applicable, also the control cable, the control-cable sheath and the necessary connections and attachments.

3.14

reserve sheath

sheath containing the length of the control cable, necessary for the projection of the source assembly

3.15

sealed radioactive source

radioactive source sealed in a capsule or having a bonded cover, the capsule or cover being strong enough to prevent contact with and dispersion of the radioactive material under the conditions of use and wear for which it was designed

NOTE In the following text, the term "sealed source" is used instead of "sealed radioactive source" for simplification.

(cf. 3.11 of ISO 2919:1999)

3.16

secured position

condition of the exposure container and source assembly, when the sealed source is fully shielded and restricted to this position within the exposure container

NOTE In the secured position, the exposure container may be unlocked.

**3.17
simulated source**

source whose structure is the same as that of the sealed radioactive source but not containing any radioactive material

**3.18
source assembly**

source holder with a sealed source attached or included

NOTE In cases where the sealed source is directly attached to the control cable without the use of a source holder, the source assembly is the control cable with the sealed source attached. In cases where the sealed source is not attached to the control cable nor included within the source holder, the sealed source is the source assembly. In the case where a simulated source is attached to or included with a source holder or control cable, this becomes a simulated source assembly.

**3.19
source holder**

holder, or attachment device, by means of which a sealed source or simulated source can be directly included in the exposure container (category I apparatus), or fitted at the end of the control cable (category II apparatus)

NOTE Source holders may be an integral part of the source assembly or may be capable of being dismantled for sealed source replacement.

**3.20
working position**

condition of the exposure container and source assembly, when in the position intended for performance of industrial gamma radiography

4 Classification

4.1 Classification of exposure containers according to the location of the source assembly when the apparatus is in the working position

4.1.1 Category I

Exposure container from which the source assembly is not removed for exposure (e.g. see Figure 1).

4.1.2 Category II

Exposure container from which the source assembly is projected out through a projection sheath to the exposure head for exposure. The projection is remotely operated (e.g. see Figure 2).

4.1.3 Category X

Apparatus for gamma radiography designed for special applications where the unique nature of the special application precludes full compliance with this International Standard, for example:

- self propelled intra-tubular gamma radiography apparatus (pipe-line crawler);
- gamma radiography apparatus for underwater use.

The exposure container shall comply with this International Standard to the maximum extent possible. Exceptions and items of non-compliance shall be described in the addenda.

4.2 Classification of exposure containers according to their mobility

4.2.1 Class P

Portable exposure container, designed to be carried by one or more persons. The mass shall be not more than 50 kg.

4.2.2 Class M

Mobile, but not portable, exposure container designed to be moved easily by suitable means provided for the purpose.

4.2.3 Class F

Fixed installed exposure container, or one with mobility restricted to the confines of a defined working location.

5 Specifications

5.1 General design requirements

5.1.1 Apparatus for industrial gamma radiography shall be designed for the conditions likely to be encountered in use.

5.1.2 The design of class P and M apparatus shall ensure that the apparatus withstands the effects of corrosion under the intended conditions of use.

5.1.3 The design of class P and M apparatus shall ensure continued operation under environmental conditions of moisture, mud, sand and other foreign materials.

NOTE If feasible, a test for continued operation under environmental conditions of moisture, mud, sand and other foreign materials, will be developed and will be issued as an addendum.

5.1.4 The design of the apparatus shall ensure satisfactory operation over the temperature range $-10\text{ }^{\circ}\text{C}$ to $45\text{ }^{\circ}\text{C}$.

5.1.5 The operating voltage and the insulation resistance of electric circuits of power-operated apparatus for industrial gamma radiography shall comply with the relevant IEC standards.

5.1.6 The design of the apparatus shall ensure that any non-metallic components (e.g. rubber, plastics, jointing and sealing compounds, lubricants) will not suffer any damage from radiation that will diminish the safety of the apparatus during its design life as specified by the manufacturer.

5.1.7 Putting the exposure container outside or into the secured position shall be possible without bringing parts of the human body into the beam of radiation.

5.1.8 Connecting or disconnecting the projection sheath and/or the remote control from the exposure container shall be possible without bringing parts of the human body into areas where the ambient equivalent dose rate exceeds 2 mSv/h (200 mrem/h).

5.1.9 The design of any replacement component, including the source assembly, shall ensure that its interchange with the original component will not compromise the design safety features of the apparatus.

5.1.10 For class P and M exposure containers, the design of the apparatus shall provide appropriate means for the secure mounting of the remote control and projection sheath (if applicable) to the exposure container in different positions of use.

5.1.11 The exposure container shall be designed in such a way as to discourage dismantling by unauthorized personnel. Those components which cause the source assembly to be retained in the secured or locked position shall be designed so that they can only be dismantled by using a special tool or removing a seal or removing a label that gives warning of the significance of the dismantling. The apparatus shall be designed so that it is impossible for the source assembly to be extracted from the back of the exposure container whilst operating the apparatus, or connecting or disconnecting the remote control.

5.1.12 All materials providing radiological protection shall maintain their shielding properties at a temperature of 800 °C. When using materials with melting temperatures below 800 °C, the designer shall take into account the need to completely contain the shielding materials at this temperature. When using materials with melting temperatures above 800 °C, the designer shall take into account the possible eutectic alloying of the shielding materials with surrounding materials at temperatures below 800 °C.

5.1.13 Wherever depleted uranium is used for shielding, it shall be clad or encased with a non-radioactive material of sufficient thickness to absorb the emitted beta radiation and to limit corrosion and prevent contamination. The source tunnel through the depleted uranium shall also be clad or encased with a non-radioactive material to limit abrasion, corrosion and consequential deformation. Limitation of abrasion shall be demonstrated by satisfactory performance of a test consisting of the examination of the simulated source assembly, to demonstrate that there is no abrasion of the source tunnel which could lead to contamination by depleted uranium.

5.1.14 The exposure container shall be designed in such a way as to maintain its shielding properties specified in Table 1 under the conditions of the tests specified in 5.8, except the accidental-drop test (5.8.4.6).

5.2 Sealed sources

Sealed sources shall be in compliance with the requirements of ISO 2919.

5.3 Ambient equivalent dose-rate limits in the vicinity of exposure containers

Exposure containers shall be made in such a way that, when in the locked position with the protective cap installed, if applicable, and loaded with a sealed source corresponding to the maximum rating, the ambient equivalent dose rate, when checked according to the shielding-efficiency test described in 6.4.1, shall not exceed the limit in column (4) and one or other of the limits in columns (2) and (3) of Table 1 for the appropriate class of exposure container.

Table 1 — Ambient equivalent dose-rate limits

1	2	3	4
Class	Maximum ambient equivalent dose rate, mSv/h (mrem/h)		
	On external surface of container	At 50 mm from external surface of container	At 1 m from external surface of container
P	2 (200)	0,5 (50)	0,02 (2)
M	2 (200)	1 (100)	0,05 (5)
F	2 (200)	1 (100)	0,1 (10)

5.4 Safety devices

5.4.1 Securing devices

5.4.1.1 Locks

All exposure containers shall be equipped with a key-operated integral lock to ensure that the change of state of the exposure container from the locked position can only be achieved by a manual unlocking operation using the key.

The lock shall be either lockable without the key, or of a type from which the key can only be withdrawn when the container is in the locked position. The lock shall retain the exposure container and the source assembly in the secured position and shall not, if the lock is damaged, prevent the source assembly when it is in the working position from being returned to the secured position. The lock shall comply with the lock-breaking tests described in 5.8.4.2 and 6.4.2.

5.4.1.2 Operation of the automatic securing mechanism

The exposure container shall be designed so that it is only possible to release the automatic securing mechanism by means of a deliberate operation on the exposure container, which may be remotely activated.

When the source assembly is returned to the location of the secured position, the exposure container and the source assembly shall go automatically to the secured position.

It shall not be possible to lock the exposure container unless the source assembly is in the secured position.

For a category II exposure container, it shall not be possible to release the source assembly from the secured position unless a secure attachment is made between the control cable and the source assembly, between the control-cable sheath and the exposure container, and between the projection sheath and the exposure container.

For an exposure container using a remote control, it shall not be possible to completely detach the remote control unless the exposure container is in the secured position.

5.4.2 Indications of secured position or not

The apparatus shall be designed such that it is possible for the operator to determine if the source holder is in the secured position from a distance of at least 5 m. If these indications are on the container, they shall be clearly recognizable at a distance of 5 m in the direction of the attachment of the remote control in normal conditions of use¹⁾. If colours are used, green shall indicate that the source holder is in the secured position and red shall indicate that the source holder is not. Colours shall not be the sole means of identification. All indications shall be clear and reliable.

Manufacturers must specify in their instructions for use of the apparatus that a radiation survey meter must be used to determine the position of the sealed source. The requirements for the radiation survey meter to be properly calibrated and functional shall be in accordance with IEC 60846.

Refer to IEC 60846 for the requirements on calibration and maintenance of radiation survey meters.

1) Some national regulatory authorities require the provision of sealed source position indicators on the exposure container. To fully comply with such requirements, it would be necessary to detect that the sealed source is in the position indicated.

5.4.3 System failure of the remote control in normal conditions of use

The remote-control system which is not manually operated shall either:

- a) be designed so that a failure of this system causes the exposure container and the source assembly to revert to the secured position; or
- b) be accompanied by an emergency device (preferably manual) and/or a procedure, permitting the return of the source assembly to the secured position.

5.5 Handling facilities

5.5.1 Class P exposure containers shall be provided with at least one carrying handle.

5.5.2 Class M exposure containers shall be provided with lifting mounts by which they can be easily hoisted.

If a trolley is used for moving a class M exposure container, its conditions for safe use shall be specified and operating instructions shall be supplied.

Where a trolley is used, it shall be tested with any immobilizing device engaged to ensure that it is not capable of moving alone down a smooth steel-plate with a slope of 10 %, and it shall not be capable of tipping on the same surface.

5.6 Source-assembly security

5.6.1 The source holder shall be designed in such a way that it cannot release the sealed source in normal conditions of use, and shall provide it with positive retention. For a reusable source holder, the sealed source must be fitted in the source holder by at least two mechanical actions having different and combined effects (e.g. screw and clip, or screw and pin).

5.6.2 It shall be possible to connect or disconnect the source assembly from the end of the control cable without the use of any tool, with the exception of a source assembly which is inseparably attached to the control cable.

5.6.3 The exposure container must be designed in such a way that the source or source assembly may not be released inadvertently.

The sealed source or the source assembly in a category I exposure container shall only be removed during routine replacement by at least two actions having different and combined mechanical effects (e.g. clip and screw).

If the unloading of the source assembly of a category II exposure container does not involve projection in a specially fitted transfer container, the above requirements for category I exposure containers shall apply.

5.7 Remote-control security

5.7.1 The remote control shall have a stop on the control cable to prevent loss of control and disengagement of the cable from the remote control.

5.7.2 Control mechanisms of the remote control shall be clearly marked to indicate the directions of control movement to expose and to retract the source assembly.

5.7.3 The remote control must comply with IEC 61000-6-1, IEC 61000-6-2 and IEC 61000-6-4 standards for electromagnetic compatibility.

5.8 Resistance to normal conditions of service

5.8.1 General

The design of the apparatus shall ensure continued operation under normal conditions of use. This shall be demonstrated by satisfactory performance of the tests indicated in this clause.

These tests shall be carried out on prototypes that shall comply with the design requirements stated in 5.1 to 5.7. Two entire apparatuses (A) and (B) (see 6.1) are required.

If tests according to IAEA-STI-PUB 998 for type B packages on the exposure container alone have been passed, the test described in 5.8.4.6 is not necessary. The other tests can be carried out with one apparatus only.

5.8.2 Endurance test (see 6.2)

This test is carried out on the entire apparatus (B), equipped with a simulated source assembly. After having undergone the endurance test described in 6.2, the apparatus must remain usable without any advanced sign of fatigue. In particular, it must be ensured that

- the automatic securing mechanism, remains operational, and
- the lock operation remains effective and in accordance with the requirements of 5.4.1.1.

5.8.3 Projection resistance test for category II exposure containers (see 6.3)

This test is carried out before and after the following tests:

- on exposure container (B) having undergone the shielding efficiency, vibration and shock tests;
- on simulated-source assembly (B) having undergone the vibration and tensile tests;
- on remote-control devices (B) having undergone the crushing and bending, kinking and tensile tests; and
- on projection sheaths (B) having undergone the crushing and bending, kinking and tensile tests.

The maximum force which shall be applied to the control lever to move the source assembly from the secured position to the working position and return it to the secured position shall be not greater than 125 % of the maximum force which it had been necessary to apply to move the source assembly in the same configuration before starting any of these tests.

5.8.4 Tests for exposure containers

5.8.4.1 Introduction

The tests referred to in 5.8.4.2, 5.8.4.3, 5.8.4.5. and 5.8.4.6., shall be carried out in the order shown on the same individual class P or M exposure container (B) which has already undergone the endurance test described in 6.2 (see 5.8.2).

The test referred to in 5.8.4.4 shall be carried out on the second class P or M exposure container (A) which has already undergone the shielding-efficiency test described in 6.4.1 (see 5.3).

An exposure container shall remain operable (the source assembly shall be brought into the working position and back to the secured position) and still comply with the corresponding requirements of this subclause and 5.3 to 5.6 after having undergone each of the following tests except the accidental-drop test.

5.8.4.2 Lock integrity

The lock shall remain operational and effective after having undergone the lock-breaking test (6.4.2), the vibration-resistance test (6.4.5) and the horizontal-shock-resistance test (6.4.6.1).

5.8.4.3 Handle, attachment part or lifting mount (see 6.4.3)

Each handle, attachment part or lifting mount which could be used for securing a class P exposure container or each lifting mount of class M exposure containers shall be designed to withstand a force equivalent to 25 times the total mass of the exposure container. The handle or lifting mount shall remain attached to the exposure container.

5.8.4.4 Vibration-resistance test (see 6.4.5)

This test is carried out on the exposure container (B) having undergone the shielding-efficiency test (see 6.4.1).

After completing the test procedure, the apparatus shall be fully operational (all functions of the apparatus continue to operate correctly).

5.8.4.5 Shock (see 6.4.6)

After having undergone the shock-resistance tests described in 6.4.6, the apparatus shall be fully operational (all functions of the apparatus continue to operate correctly).

5.8.4.6 Accidental drops (see 6.4.4)

After the exposure container has been subjected to the accidental-drop test in 6.4.4, the sealed source shall be retained in the exposure container and the ambient equivalent dose rate shall not exceed 1,5 times the limits specified in column 4 of Table 1.

Conformity with the specification laid down shall be checked by extrapolation from tests carried out using a sealed source of activity which is sufficient for the results obtained to be significant, taking into account the sensitivity threshold of the measuring methods and instruments.

5.8.5 Tensile test for the source assembly and its connecting devices for category II exposure containers (see 6.5)

This test shall stress each individual part of the source assembly (B).

The source assembly shall remain operable and maintain its structural integrity after having undergone the tensile test.

At the conclusion of this test, the complete system shall remain operable.

5.8.6 Crushing and bending (see 6.6.1), kinking (see 6.6.2) and tensile (see 6.6.3) tests for remote control

These tests shall be performed on the same individual remote control (B) in the order indicated.

At the conclusion of these tests, the remote control shall maintain integrity.

Additionally, the remote control shall remain operable and the exposure container shall comply with the requirement of Table 2.

When the remote control is laid out as shown in Figure 3, the maximum force which shall be applied to completely project out and retract the control cable through the exposure container (the projection sheath being in the rectilinear position) shall be not more than 125 % of the maximum force which had to be applied before the test, when the remote control was in the same configuration before the tests.

At the conclusion of these tests, the complete system shall remain operable.

Table 2 — Tests

Equipment		Specifications					Test		
		Type ^a	Category		Class			Type	Subclause
		I	II	P	M	F	Subclause		
Entire apparatus	(B)	X	X	X	X	X	5.8.2	Endurance	6.2
	(B)	X	X	X	X	X	5.8.3	Projection resistance before and after endurance tests	6.3
Exposure container	(A)(B)	X	X	X	X	X	5.3	Shielding efficiency	6.4.1
	(B)	X	X	X	X	X	5.8.4.2	Lock breaking	6.4.2
	(B)	X	X	X	X		5.8.4.3	Handle, attachment part or lifting mount	6.4.3
	(B)	X	X	X	X		5.8.4.4	Vibration resistance	6.4.5
	(B)	X	X	X	X		5.8.4.5	Shock	6.4.6
	(A)	X	X	X	X	X	5.8.4.6	Accidental drops	6.4.4
Source assembly and its connecting device		X					5.8.5	Tensile	6.5
Remote control	(B)	X	X	X	X		5.8.6	Crushing and bending	6.6.1
	(B)	X	X	X	X		5.8.6	Kinking	6.6.2
	(B)	X	X	X			5.8.6	Tensile	6.6.3
Projection sheaths	(B)	X	X	X	X		5.8.7	Crushing and bending	6.7.2
	(B)	X	X	X	X		5.8.7	Kinking ^b	6.7.3
	(B)	X	X	X			5.8.7	Tensile	6.7.4

^a The tests are performed on two different apparatuses, indicated (A) and (B).
^b Test to be carried out only on flexible projection sheaths.

5.8.7 Crushing and bending (see 6.7.2), kinking (see 6.7.3) and tensile (see 6.7.4) tests for projection sheath (see Figure 5)

These tests shall be performed on the same individual (B) projection sheath in the order indicated.

The projection sheath shall remain completely and safely operable (the projection sheath shall not have suffered any damage which would prevent the source assembly from sliding through the projection sheath) and still comply with the requirements of this subclause after having undergone each of the crushing and bending (see 6.7.2), kinking (see 6.7.3) and tensile (see 6.7.4) tests.

At the conclusion of these tests, the projection sheath shall maintain integrity and it shall be shown that any elongation will have no detrimental effect on safety.

At the conclusion of these tests, the complete system shall remain operable.

6 Tests

6.1 Performance of the tests

Approval testing of prototypes should be carried out according to ISO 9000 by

- a) either a body independently accredited according to ISO 9000, or
- b) a body which is recognized by a national government as being qualified to make a full and impartial assessment.

The organization carrying out the tests shall have access to the documents listed in Clause 10.

Unless the test organization has already carried out identical tests or more constraining tests for other regulations, the two prototype apparatuses referenced (A) and (B) shall be subjected to the tests given in Table 2 in the order indicated, and shall fulfil the criteria for the individual tests specified in 5.8.

If the exposure container is designed for use in more than one class and/or category, the prototype shall be subjected to the tests of each appropriate class and/or category.

In addition to these prototype tests, a test to prove the shielding efficiency shall be carried out by the manufacturer on each exposure container manufactured. Similarly, a test for checking the quality of the source assembly shall be carried out by the manufacturer on each source assembly manufactured, according to Clause 11.

6.2 Endurance test

6.2.1 Objective

The test aims to check the resistance to fatigue and wear of the different components utilized during the movement of the state of the exposure container from the secured position to the working position, and its return to the secured position (in particular, the automatic securing mechanism, connecting devices between the remote control and the source assembly, and any related indicators).

6.2.2 Principle

The test shall be carried out in such a manner that the normal operating sequences of the apparatus be alternately reproduced by the inversion of the movement direction.

During each cycle, the automatic securing mechanism must be released and the source assembly must move from the secured position to the working position and then return to the secured position.

Movement rate:

- The minimum movement rate for the category I exposure container shall be 30 revolutions per minute or one second per full cycle, whichever is faster. The movement rate must remain constant until the source assembly is stopped at each half of the cycle.
- The minimum movement rate for the category II exposure container shall be 0,75 m per second of linear movement of the source assembly. The movement rate must remain constant until the source assembly is stopped at each end of the cycle.

The force required to perform the test shall be twice that measured in accordance with 6.3 (projection-resistance test).

6.2.3 Procedure

The complete category II exposure container fitted with the remote control and projection sheaths shall be set up coupled to the test device. The projection length will be the maximum length recommended by the manufacturer in the specification.

The mounting of these accessories on the apparatus shall be carried out according to the configuration given in Figure 6, adjusting for length as detailed in Figure 6.

For categories I and II, the total number of cycles shall be carried out according to Table 3.

Table 3 — Cycles for endurance test

Types of cycles	Number of cycles
Normal cycles	50 000
Cycles for the remote-control emergency device(s), if any ^a	10
Total number of cycles	50 010
^a Cycles carried out on the emergency device for non-manually operated remote controls.	

For category I exposure containers, the entire normal cycle consists of changing the remote control from the secured position to the working position and back to the secured position. For category II exposure containers, the entire normal cycle consists of moving the source assembly from the secured position to the working position and back to the secured position.

The test shall not be interrupted before the first 10 000 cycles and not more than four times during the whole test to carry out the common maintenance operations (cleaning and lubrication only).

No maintenance of the source assembly or its connection to the remote control is permitted before the source assembly has been subjected to a number of test cycles equal to twice the number of cycles for which it is designed. This number of cycles cannot be less than 10 000, as specified in the documentation referred to in Clause 9. In all other cases, no maintenance is permitted before the end of the test (50 000 cycles).

6.3 Projection-resistance test

This test shall be performed on the category II exposure container before and after the operational tests (5.8.3).

6.3.1 Principle

The purpose of this test is to determine the resistance offered to projection by

- the exposure container after the vibration- and shock-resistance tests (6.4.5 and 6.4.6),
- the source assembly after the tensile test (6.5),
- the remote control and the cable after the crushing and bending, kinking and tensile tests (6.6.1 to 6.6.3), and
- the projection sheath and its exposure head after the crushing and bending, kinking and tensile tests (6.7.2 to 6.7.4).

6.3.2 Equipment

The exposure container shall be equipped with a source assembly having the largest diameter and greatest length compatible with the projection sheath undergoing examination (in accordance with the manufacturer's instructions that accompany the equipment).

The crankshaft driving motor of the test equipment shall be provided with a force or torque measuring and recording device.

6.3.3 Procedure

Connect the remote control to the exposure container following the configuration shown in Figure 6.

Connect to the exposure container the maximum length of projection sheath (as stipulated by the manufacturer) which has undergone tests. For flexible projection sheaths, use the configuration shown in Figure 6. The bending radius stipulated for each change in direction is the minimum bending radius as specified by the manufacturer.

If the maximum length of the projection sheath is not sufficient to accommodate the complete configuration, the projection sheath shall follow this configuration as closely as possible.

Before and after the tests indicated in 6.3.1, carry out 10 complete cycles of moving the source assembly from the secured position to the working position and returning it to the secured position, recording the driving force on each cycle. The linear-movement rate shall be that specified in 6.2.2.

6.4 Tests for the exposure container

6.4.1 Shielding-efficiency test (see 5.3)

6.4.1.1 Principle

The test consists of checking the radiation leakage from the exposure container to ensure that the radiation doses are within the limits specified in this International Standard (see Table 1 in 5.3).

6.4.1.2 Procedure

Remove the remote control and projection sheaths and carry out the test on the exposure container alone in the locked position with the protective caps, plugs or similar devices in place. Before measuring the levels at the surface or at 50 mm from the surface, check by a smear test (in accordance with ISO 7503-1) that the surface of the container has no radioactive contamination.

Load the exposure container with a sealed source of the appropriate radionuclide and known activity. Measure the ambient equivalent dose rate over the entire exposure-container surface, either at the surface or at 50 mm from the surface, together with further measurements at 1 m from the surface, to determine that the ambient equivalent dose-rate limits given in 5.3 are not exceeded at any place and in any direction.

Measure the ambient equivalent dose rate at the surface of the exposure container using an X-ray film or other appropriate device with a cross-sectional area no greater than 10 cm². Measure the ambient equivalent dose rate at 50 mm from the surface using a detector with a cross-sectional area no greater than 10 cm² and no linear dimension greater than 5 cm. Measure the ambient equivalent dose rate at 1 m from the surface using a detector with a cross-sectional area no greater than 100 cm² and no linear dimension greater than 20 cm.

Extrapolate the ambient equivalent dose rates obtained to derive the dose rates for a maximum rating of the exposure container. Extrapolation shall take into account the sensitivity of the radioactivity-measuring instruments, and ideally the maximum activity shall be used.

In the case of a class F exposure container, the ambient equivalent dose rates in inaccessible positions need not be measured.

NOTE Information on radiation leakage testing is to be found in ISO 2855.

6.4.2 Lock-breaking test (see 5.8.4.2)

6.4.2.1 Principle

The test consists of checking that the exposure-container lock withstands a breaking force when it is in the locked position with the key removed.

6.4.2.2 Equipment

A device is fitted to the component of the exposure container which is secured by the lock. This device must be capable of applying a measured force or a torque.

6.4.2.3 Procedure

Determine the most vulnerable part of the locking mechanism.

Gradually apply a force F so as to obtain 400 N after 10 s. Maintain this force for 5 s. Then release it gradually over 10 s.

Repeat this test ten times in succession.

Check that the exposure container cannot be opened without undoing the lock.

6.4.3 Handle, attachment part or lifting-mount test (see 5.8.4.3) for class P and class M only

6.4.3.1 Principle

The test consists of determining that each carrying handle, attachment part or lifting mount is able to withstand a static force equal to 25 times the weight of the exposure container.

6.4.3.2 Procedure

Apply a force equal to 25 times the weight of the exposure container to the most vulnerable portion of the carrying handle, attachment part or lifting mount.

Ensure that the carrying handle, attachment part or lifting mount remains functional and attached to the exposure container.

6.4.4 Accidental-drop test (see 5.8.4.6)

6.4.4.1 Principle

The test consists of subjecting the exposure container in the locked position (including protective caps, plugs or similar devices) to a free drop to simulate accident conditions, with a view to ensuring that the source assembly is not accidentally exposed as a result of the drop.

The test shall consist of a single drop onto a target.

6.4.4.2 Procedure

- a) The exposure container shall drop onto the target so as to suffer the most significant effect on radiological safety.
- b) The height of drop measured from the lowest point of the exposure container to the upper surface of the target shall be 1,2 m.

- c) The target shall be a flat horizontal surface such that any increase in its resistance to displacement or deformation upon impact by the exposure container would not significantly increase the damage to the exposure container.

One example of a target of this type is a steel plate on the upper surface of a block of concrete, the mass of which is at least ten times that of any specimen to be dropped onto it. The block should be set on firm soil and the steel plate on its upper surface should be at least 12,5 mm thick and wet floated onto the concrete so as to be in intimate contact with it. The target should have plane dimensions at least 500 mm larger on all sides than any specimen that is to be dropped onto it and it should be as close to cubic in form as practicable.

6.4.5 Vibration-resistance test (see 5.8.4.4) for class P and class M only

6.4.5.1 General

The principle, terminology and method used for this test are in accordance with IEC 60068-2-6.

6.4.5.2 Principle

The purpose of the test is to determine the natural frequencies which are characteristic of the exposure container and to study the change in these natural frequencies in order to determine if the exposure container is able to withstand vibrations experienced during transportation.

NOTE 1 Natural frequencies are defined as frequencies whose mechanical resonances deviate by more than 30 % from the maximum acceleration given in 6.4.5.5.1 (defects in assembly and mechanical connection of constituting elements, or when other signs of response, such as impact noise or internal hammering, occur).

NOTE 2 The conditions and values of vibratory parameters applied are generally characteristic of usual transportation conditions.

6.4.5.3 Equipment

The testing device (vibrating platform) shall be in accordance with IEC 60068-2-6 to vibrate the parts of apparatus under test along three orthogonal axes, while respecting the usual transport position of the exposure container.

6.4.5.4 Source assembly

This test shall be applied to the exposure container loaded with a simulated-source assembly in the locked position including protective caps, plugs or similar devices, with the remote control and projection sheaths removed.

6.4.5.4.1 Mounting of the exposure container

The exposure container shall be rigidly mounted on the testing device, in accordance with IEC 60068-2-47, so that it cannot move independently of the platform. This mounting shall not alter the natural frequency of the exposure container under test.

6.4.5.4.2 Positioning and mounting of the accelerometers

Accelerometers shall not be located on riveted pieces, in their immediate vicinity, or on devices with rotating or translating mechanisms (e.g. cylindrically operating shutter(s), or slide-operating shutter(s)).

Accelerometers shall be adequately located, and in a sufficient number, so that the obtained accelerometric response provides sufficient data to test for mechanical resonances.

They shall be mounted on the exposure container under test in accordance with IEC 60068-2-47.

6.4.5.5 Procedure

The exposure container, including a simulated source assembly, is subjected to the vibration test.

The testing procedure consists of three test runs:

- test for endurance through sweeping to determine natural frequencies;
- test for endurance at natural frequencies;
- test for endurance.

Apply each test successively along two orthogonal axes.

6.4.5.5.1 Endurance through sweeping (determination of natural frequencies)

The exposure container is subjected along two orthogonal axes (for a category II exposure container, one axis must be parallel to the direction of the source assembly movement) to vibratory severity defined by the combination of the three following parameters:

- frequency range: 10 Hz \pm 1 Hz to 150 Hz \pm 3 Hz;
- maximum acceleration: 9,8 m s⁻²;
- duration of stress: 1 sweeping cycle (the frequency range is from 10 Hz to 150 Hz and back to 10 Hz) by a sweeping rate of 1 octave min⁻¹ within 10 %.

The sweeping shall be continuous (continuous change of the frequency according to the time) in order to avoid sudden rises of frequency which generate spurious natural frequencies.

6.4.5.5.2 Endurance at natural frequencies

The exposure container is subjected to each natural frequency obtained during the test described in 6.4.5.5.1 for a period of 30 min \pm 1 min at the same maximum acceleration as in 6.4.5.5.1. The test may be carried out in a frequency range of \pm 10 % around the obtained natural frequencies.

In the case where several natural frequencies are detected along the same axis, this time period is equally distributed on each of the frequencies (with no more than three frequencies per axis).

6.4.5.5.3 Endurance

The exposure container is subjected, in the same way as in 6.4.5.5.1, to

- 15 sweeping cycles if the endurance at natural frequencies has been performed, or
- 25 sweeping cycles if no natural frequency has been detected.

6.4.6 Shock-resistance test (see 5.8.4.5)

This test shall be made after the vibration test. It shall be made on the exposure container (B), including a simulated source assembly, without the remote control and projection sheaths, but locked and with the protective caps in place. The test consists of simulating the different shocks which an apparatus may undergo, either when carried at arms length (horizontal shock when colliding with an obstacle), or when carried on a trolley (vertical shock when passing over an obstacle), in order to determine its resistance to such a shock.

6.4.6.1 Class P exposure containers — Horizontal shock

6.4.6.1.1 Equipment

The target shall consist of the flat vertical end-face of a 50 mm diameter steel bar, 300 mm in length lying horizontally, that is fixed or welded to a rigid mass at least ten times the mass of the exposure container.

The means of suspension shall not produce undesirable rotation of the exposure container around a vertical axis prior to the shock.

6.4.6.1.2 Procedure

Select the areas on the exposure container which, if impacted, will have the most significant effect on radiological safety. Suspend the exposure container from fixed points so placed that, when at rest, one of the selected areas just touches the target. Move the exposure container from its resting position until its centre of gravity is 100 mm higher than in the resting position and let it loose, so that it swings in a pendulum movement against the target. Carry out these shocks 20 times on each of the selected areas.

6.4.6.2 Class P exposure containers — Vertical shock

6.4.6.2.1 Equipment

The rigid target (e.g. steel or concrete) shall consist of a mass at least ten times that of the exposure container and have a flat horizontal surface covered with a sheet of hard plywood 25 mm thick (7 or 9 ply).

6.4.6.2.2 Procedure

From its normal carrying position, let the exposure container fall 100 times from a height of 150 mm onto the rigid target.

The test may be carried out either manually or with the aid of a suitable mechanical device.

6.4.6.3 Class M exposure containers

Carry out the test by letting the exposure container on its trolley, or other device provided for ease of movement, moving at a speed of at least 1m/s, drop freely down a step of height 150 mm. The edge of the step shall be such that it will not be distorted by the operation.

The ground at the bottom of the drop shall be hard and solid (e.g. concrete or flagstones). If this is not the case (e.g. wood or beaten earth), cover the ground with a steel sheet at least 10 mm thick.

Do this test 100 times.

6.5 Tensile test for source assembly

6.5.1 General

This test shall be performed on the category II exposure container before and after the operational tests (see 5.8.5).

6.5.2 Principle

The purpose of this test is to determine the ability of the source assembly, with a simulated source, to withstand the tensile stress to which it is subjected during use.

6.5.3 Procedure

Perform the following two tests:

- a) Attach a control cable to the source assembly to be tested. Restrain the opposite end of the source assembly. Apply a tensile force gradually to the control cable so as to obtain 1 000 N after 10 s and maintain the force for 5 s. Do this test 10 times.
- b) Attach a control cable to the source assembly to be tested. Restrain the largest diameter of the source assembly (i.e. that portion which is used to stop the retraction of the source assembly when it reaches the secured position within the exposure container). Apply a tensile force gradually to the control cable so as to obtain 1 000 N after 10 s and maintain the force for 5 s. Do this test 10 times.

6.6 Tests for remote control

6.6.1 Crushing and bending tests (see 5.8.6)

6.6.1.1 Principle

The test simulates the crushing and bending of the control-cable sheaths by the heel of a person's footwear.

6.6.1.2 Equipment

The test surface shall be plane and horizontal with a mass of 150 kg and sufficiently hard not to be deformed when the steel heel is applied to it without the presence of test pieces. The device consists of a crank 1 m long, attached such that it can swing at its upper end and fitted with a 70 mm × 70 mm steel plate at the lower end of the crank. The edges of the heel are rounded to 2 mm radius on the horizontal edges and 5 mm radius on the vertical edges (see Figure 5). The heel and crank shall have a mass of 15 kg. In addition, two steel bars, each 50 mm in diameter and 300 mm in length shall be required for testing rigid sheaths.

In the case where the projection and reserve sheaths are attached to each other (construction-bound sheaths), the test surface is fitted with lateral guides preventing the relative movement of the sheaths during the impact. The guides shall have the following characteristics:

- length greater than two heel lengths;
- height between 0,5 and 0,75 times the sheath height for juxtaposed sheaths and between 1,5 and 1,75 times the sheath height for superimposed sheaths.

6.6.1.3 Procedure

For flexible sheaths, place the sheath (with the control cable inserted) flat on the test surface. Place the heel at a point on the sheath. If two sheaths are juxtaposed, the heel is dropped on both sheaths simultaneously.

For rigid sheaths, place the two steel bars parallel to each other and separated by a distance of 0,5 m between the axes. Place the rigid sheath in a direction perpendicular to the bars along the mid-plane of the bars. Place the heel at a point on the sheath midway between the steel bars.

By lifting the crank, raise the bottom of the heel 300 mm higher than the upper surface of the sheath. Drop the crank in a free-swinging movement. Do this test once on ten randomly selected points on the sheath, one of which shall be on a joint if there is one.

For construction-bound sheaths, the test is performed on the control cable inserted in the two sheaths at random points as follows:

- five points when the sheaths are laid out juxtaposed, with the heel dropping onto both sheaths simultaneously;

- five points when both sheaths are superimposed in a vertical plane with the heel dropping onto the top sheath.

(In both cases, the sheaths are laterally held by guides.)

6.6.2 Kinking test (see 5.8.6)

6.6.2.1 Principle

The purpose is to subject the remote control to the stress that it may undergo as a result of kinking forces that may occur during setting up of the remote control for use.

6.6.2.2 Procedure

Arrange the control cable and sheath(s) rectilinearly on a plane horizontal surface. Secure one end of the sheath(s) so that it does not move in any way during the test. With the sheath(s), make a loop 500 mm in radius on the horizontal surface. Pull the free end of the sheath(s), without allowing it to rotate, along the axis of its original line, at a speed of 2,0 m/s until the loop disappears and until the sheath(s) regains its rectilinear position.

Do this test 10 times at each of 10 equidistant points over the length of the sheath(s) tested, each point being the origin of the loop.

6.6.3 Tensile test (see 5.8.6)

6.6.3.1 Principle

The test consists of simulating the tensile stress which may be experienced by the unit composed of the control-cable sheath(s), control cable and connectors, and its control mechanism, during use.

6.6.3.2 Procedure

- a) The control-cable sheath(s) shall be fitted on the remote-control mechanism.
 - Secure the remote control so that it cannot move during the test without immobilizing the control mechanism (e.g. control lever).
 - Apply a tensile force of 500 N for 30 s to the end of the control sheath connected to the exposure container.
 - Do this test 10 times.
- b) The control cable shall be fitted to the control mechanism.
 - Secure the remote control so that it does not move during the test. Immobilize the control mechanism (e.g. lever). Connect a source assembly to the control cable. Apply a force of 1 000 N for 10 s to the free end of the source assembly. Do this test 10 times.

6.7 Tests for projection sheaths and exposure heads (see 5.8.7)

6.7.1 Introduction

Rigid projection sheaths shall undergo tests 6.7.2 and 6.7.4, in that order.

Flexible projection sheaths shall undergo tests 6.7.2, 6.7.3 and 6.7.4, in that order.

The criteria for passing these tests are specified in 5.8.6.

6.7.2 Crushing and bending test (see 5.8.7)**6.7.2.1 Principle**

The test simulates the crushing and bending of the projection sheath by the heel of a person's footwear.

6.7.2.2 Equipment

The same as described in 6.6.1.2.

6.7.2.3 Procedure

The same as described in 6.6.1.3.

6.7.3 Kinking test (see 5.8.7)**6.7.3.1 Principle**

The purpose is to subject the projection sheaths to the stress that they may undergo due to kinking forces that may occur during setting up for use.

6.7.3.2 Procedure

Place the projection sheath without a connection between two parallel plates separated by no more than 5 times the outside diameter of the projection sheath. Form a flat, closed loop and fix one of the ends so that it does not move in any way during the test.

Apply a tractive force to the free end, at a tangent to the loop, reducing the diameter of the loop. This force is applied via a dynamometer in such a way that it reaches 200 N in 5 s: it is then maintained at this level for 10 s.

Do this test 10 times, undoing and redoing the loop at the same point for each test.

If the projection sheath is composed of various sections with connections, restart the test including a connection in the loop.

Close the loop as above so that the connection and the crossing point are opposite each other.

6.7.4 Tensile test (see 5.8.7)**6.7.4.1 Principle**

The test consists of simulating the tensile stress which the projection sheath undergoes in use. The test is applicable only to class P and class M exposure containers.

6.7.4.2 Procedure

Connect the end of the projection sheath to the exposure container. Fix the exposure container so that it cannot move during the test.

Apply a tractive force of 500 N to the final section of the sheath or, if this section ends in a connection, apply the tractive force to the exposure-head part of the connection.

Maintain this force for 30 s.

Do this test 10 times.

7 Marking

7.1 Exposure container

7.1.1 Each exposure container or a metallic plate permanently fixed to the exposure container shall be permanently and indelibly marked with the information shown in 7.1.2 to 7.1.9, by engraving, stamping or other means.

7.1.2 The basic ionizing radiation symbol and the word "RADIOACTIVE" in letters not less than 10 mm in height; complying with ISO 361.

7.1.3 The maximum rating of the exposure container for the intended radionuclide(s). This should be expressed both in becquerels and in curies, the curies value being in brackets; for example, 3,7 TBq (100 Ci).

7.1.4 The number of this International Standard and the year of edition, i.e. ISO 3999:2004, to signify compliance with this International Standard. This ISO marking indicates the manufacturer's claim that the apparatus conforms to this International Standard. This claim shall be stated in the manufacturer's literature.

7.1.5 The manufacturer's name, equipment type and serial number.

7.1.6 The class of the exposure container.

7.1.7 The category of the exposure container.

7.1.8 The total mass of the exposure container.

7.1.9 The mass of depleted uranium, if applicable, or the sentence "Contains depleted Uranium".

7.2 Source holder or source assembly

Each source holder or source assembly shall be marked so that the following are visible with the word "RADIOACTIVE" or the ionizing radiation symbol, and where practicable, the manufacturer's identification mark and the type and serial number of the holder.

The symbol and inscription shall withstand fire, water and a 10^8 Gy (10^{10} rad) dose of gamma radiation.

Each symbol shall, if possible, be fully visible to an observer located at 0,5 m from the marking.

8 Identification of the sealed source in the exposure container

The exposure container shall be designed for the provision of attachment of a label, bearing the following information for the sealed source used in the device:

- chemical symbol and mass number of the radionuclide;
- activity and the date on which the activity was measured, in becquerels, and in curies between brackets;
- identification number of the sealed source;
- identity of the source manufacturer.

Consideration shall be given to the durability of the label and its fixing, including thermal and corrosion resistance.

9 Accompanying documents

All apparatus for industrial gamma radiography shall be accompanied by documentation referred to as "Accompanying Documents", which shall always be provided with the apparatus, intended for the users.

This documentation is divided into five categories:

- description and technical characteristics of the apparatus;
- certificates of the manufacturer;
- instructions for use;
- inspection, maintenance and repair procedures;
- instructions for disposal.

9.1 Description and technical characteristics of the apparatus

9.1.1 Description

The following information shall be provided:

- a clear indication of the intended use of the apparatus with a **warning against its use by unqualified personnel or when safety procedures are not fully met, stating that “life-threatening dangers could result”, particularly when there is a possibility of extraction and projection of the source assembly;**
- suitable photographs or drawings to allow the identification of each of the main elements and parts of the apparatus, including the source assembly;
- basic diagram of the exposure container, remote control, projection sheath and exposure head;
- explanation of operation, with reference to diagrams, clearly indicating the sequences during which the source assembly is partially or completely outside of the exposure container or exposure head;
- explanation of the operation, with reference to diagrams, and description of the means by which, as a minimum, the requirements in 5.4.2 (Indications of secured position or not) are met; such means may be visual, audible or mechanical.

9.1.2 Technical characteristics

Indication of all characteristics which are essential to know for the correct use and operation of the apparatus, and in particular:

- shielding materials used in the apparatus;
- references of the remote control(s) and projection sheath(s) that may be used with the exposure container;
- minimum bending radius allowable for this (these) sheath(s);
- specifications of characteristics of sealed sources that can be used in the exposure container (see ISO 2919), including the suitable classification and other essential specifications;
- specifications of the source holder(s) that can be used in the exposure container;
- maximum activity of each of the radionuclides that can be used in the exposure container;
- retention device of the source holder;

- where beam limiter(s) are provided, maximum transmission factor of the possible beam limiter(s) and the geometric characteristics (i.e. size and shape) of the emitted beam;
- maximal projection length with the remote control(s) that can be used on category II exposure containers;
- nature, type, voltage and capacity of batteries and cells and/or bulbs, where applicable;
- nature, voltage and intensity of the feed current which may be required for operating the equipment or recharging the accumulator batteries;
- basic diagram for the electrical circuits, if any.

9.2 Certificates of the manufacturer

With each apparatus, the manufacturer shall provide

- a certificate of conformity to show compliance with this International Standard, and
- a certificate of ambient equivalent dose-rate measurements, extrapolated to the maximum rating, taken on the exposure container.

9.3 Instructions for use

The following instructions shall use only the terms defined in Clause 3:

- instructions for assembling the various parts of the apparatus in its various configurations including exposure heads;
- instructions stating the order in which the various operating phases are to be carried out, once the assembled apparatus is in use, **with a warning of the risk of radiation exposure that may result from non-observance of these instructions**;
- instructions on the storage of the exposure container;
- instructions on the use of protective caps, plugs or similar devices on the apparatus while not in use, so as to avoid accidental penetration by foreign bodies.

9.4 Inspection, maintenance and repair procedures

The following information shall be supplied:

- instructions on replacing the loaded source assembly and the packaging of the decayed source for transportation and disposal;
- instructions on the procedure and frequency of maintenance operations;
- instructions for remote-control maintenance;
- instructions for checking the apparatus (including the exposure container, remote control, projection and reserve sheaths, exposure head) for internal cleanliness, deformation, breakage or wear;
- instructions to be followed in the event of foreseeable accidents, with an indication of their probable causes.

9.5 Instructions for disposal

The user shall be informed that, when the exposure container and sealed source have reached the end of their working life, **they shall be disposed of in a safe and proper way in accordance with national regulations**, in particular for packaging and transportation.

10 Supplementary documents for the test laboratories to conduct the conformity study

In addition to the documents provided for the user, specified in Clause 9, the following documents shall be provided to the authority responsible for carrying out prototype testing:

- complete drawings of construction for the prototype exposure container and its accessories;
- description of construction with figures and dimensions of the exposure container and designation of all the elements;
- list of tests for maintenance and repair to be carried out by the manufacturer;
- attenuation factors for the minimum thickness of shielding material for each of the radionuclides to be contained in the exposure container;
- description of the tensile test used for checking each source assembly and its connecting device.

11 Quality-assurance programme

A quality-assurance programme, such as that specified in ISO 9000, ISO 9001 or ISO 9004 or the IAEA regulations STI-PUB 998 for the design, manufacture, testing, transport, inspection and documentation of all apparatus for industrial gamma radiography, shall be established. Each manufacturer of such apparatus shall have developed a quality-assurance program appropriate to the complexity and quantity of apparatus being designed and manufactured.

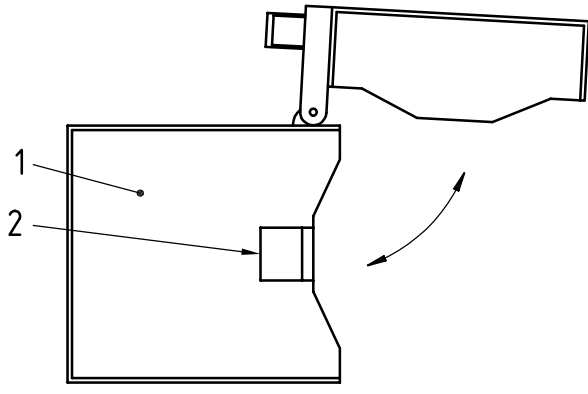
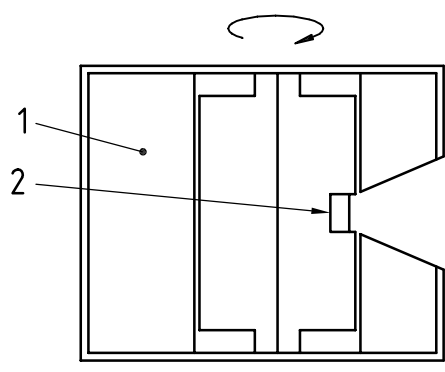

Working position

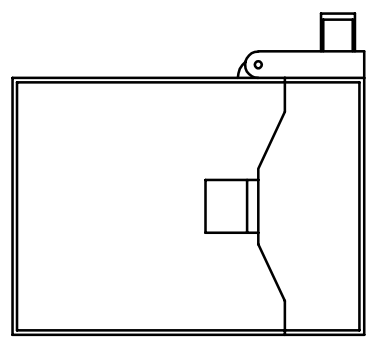
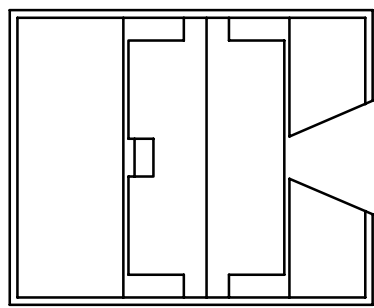

a) Rotating type

b) Shutter type

Secured position

Key

- 1 exposure container
- 2 sealed radioactive source

Figure 1 — Sketches of category I industrial gamma radiography apparatus

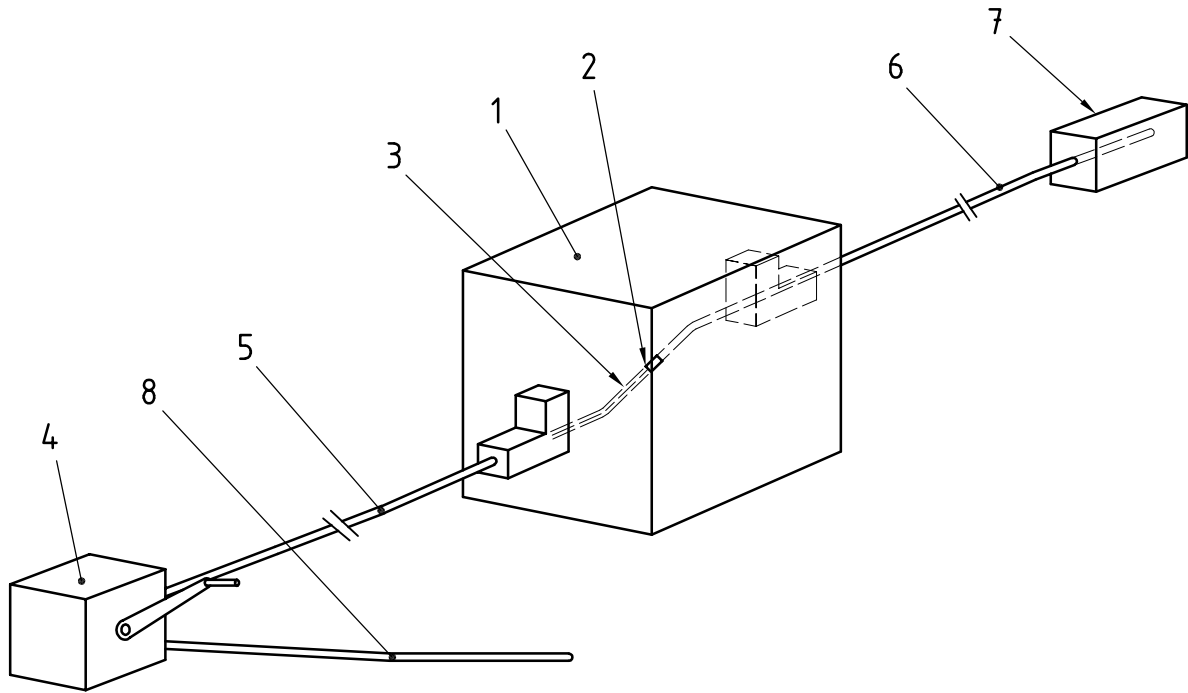

Key

- 1 exposure container
- 2 sealed radioactive source
- 3 source holder
- 4 remote control
- 5 control cable and sheath
- 6 projection sheath
- 7 exposure head
- 8 reserve sheath

Figure 2 — Sketch of category II industrial gamma radiography apparatus

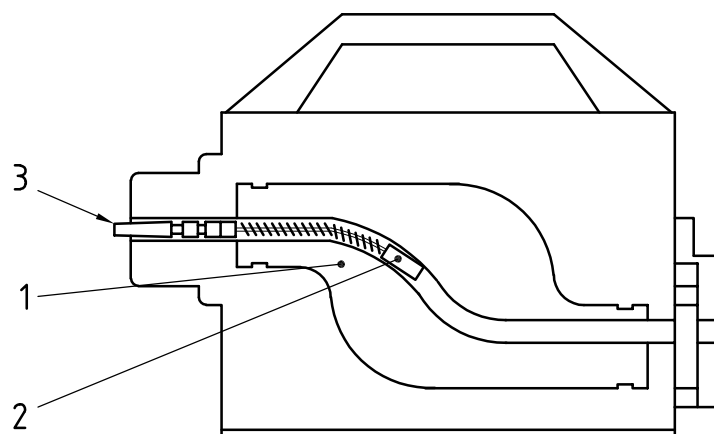

a) S-shaped model

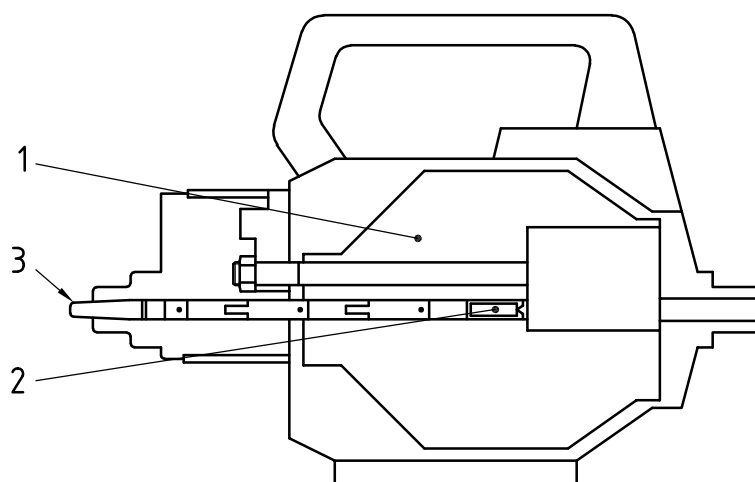

b) Rotating model

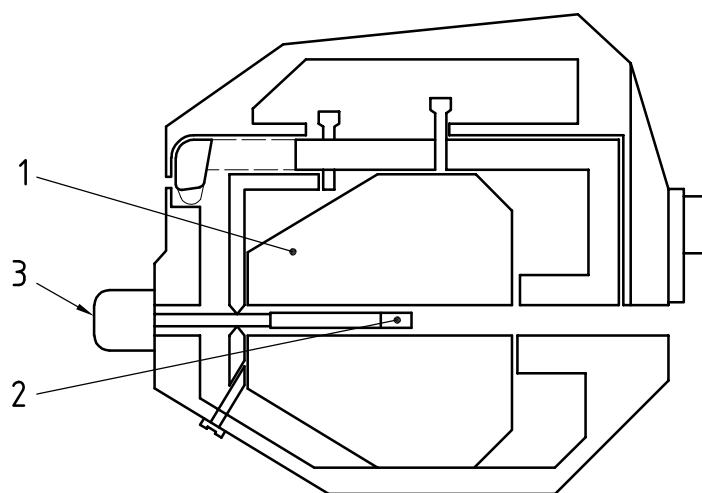

c) Finger-type model

Key

- 1 shield
- 2 sealed radioactive source
- 3 attachment for control cable and sheath

Figure 3 — Examples of category II exposure containers

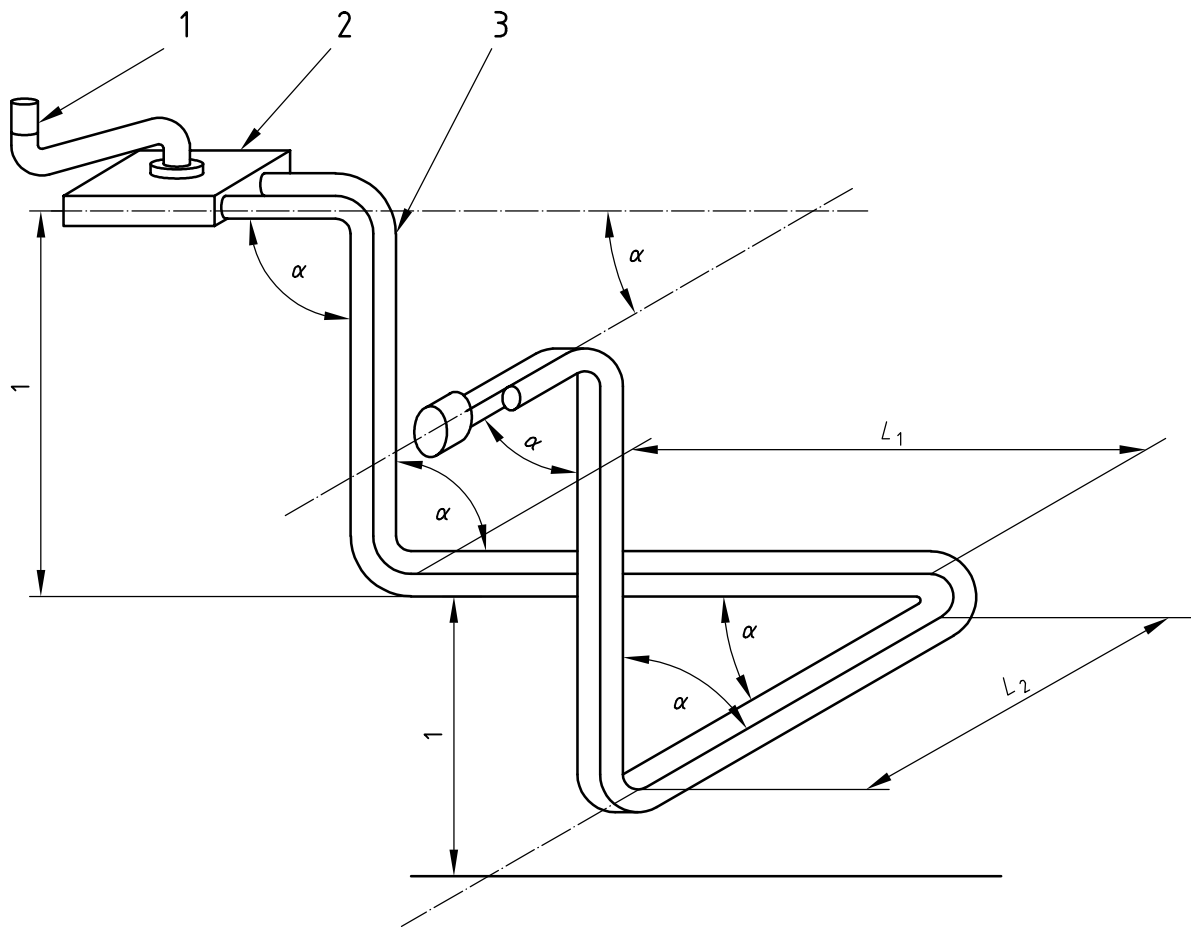

Key

- 1 control lever
- 2 control mechanism
- 3 control cable and sheath(s)

$\alpha = 90^\circ$ change in direction, with the minimum bending radius allowable for the remote-control sheath, as indicated in accompanying documents.

The control cable and reserve sheath are presented bonded as construction-bound sheaths.

Figure 4 — Remote-control test geometry (see 5.8.6)

Dimensions in millimetres

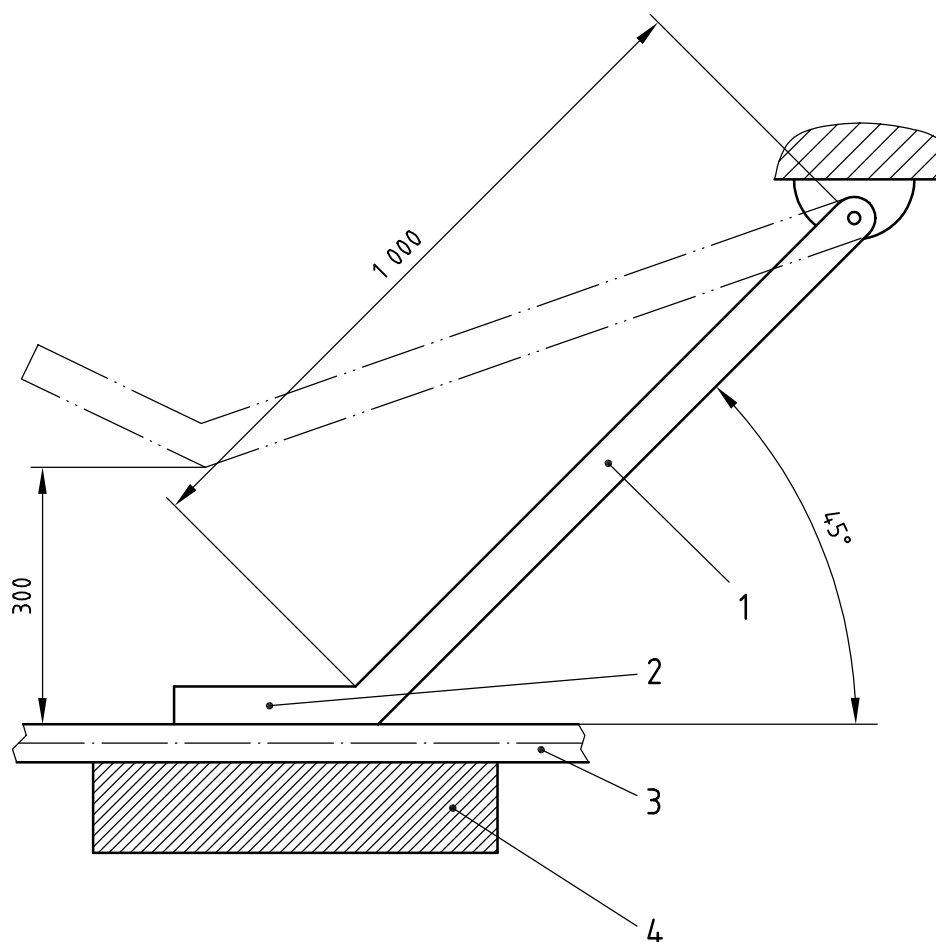

Key

- 1 crank
- 2 heel
- 3 testing sheath
- 4 test surface

Figure 5 — Example of device for crushing test (see 6.6.1)

Dimensions in metres

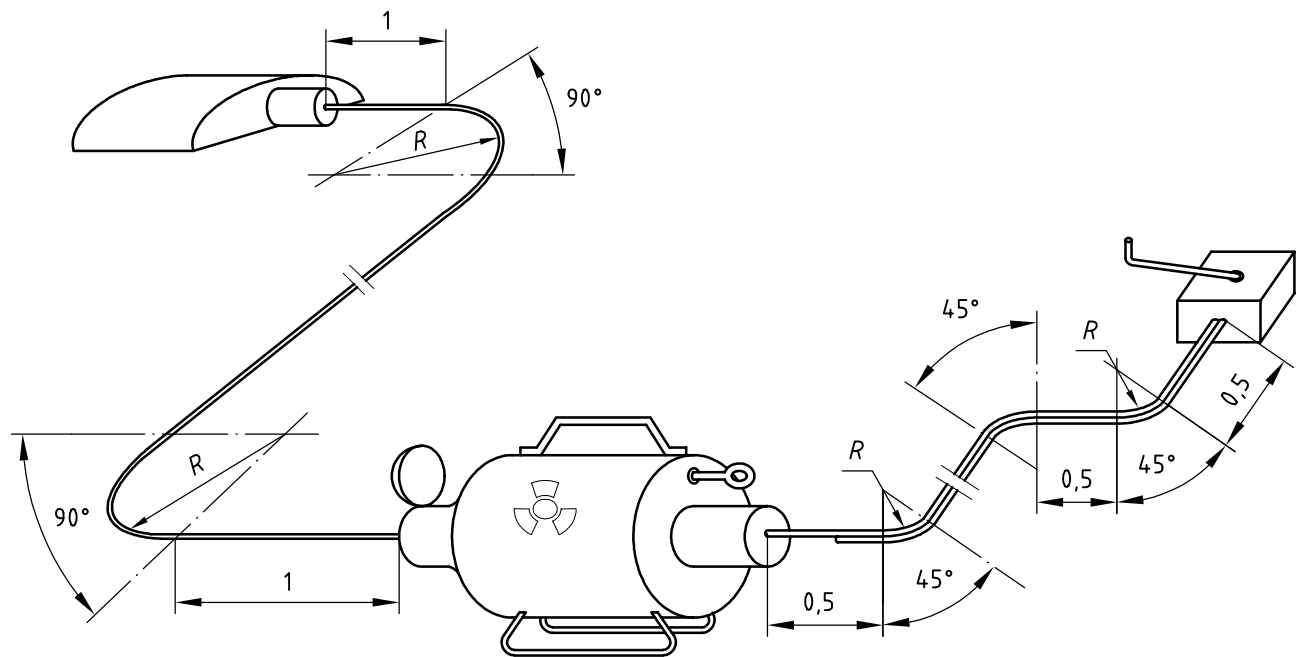

For the endurance test and for projection-resistance tests (see 6.2.3 and 6.3.3).

Remote control:

- for lengths ≥ 3 m: 3 bends with 45° into 2 planes and 2 levels ($H = 1$ m);
- for lengths < 3 m: follow above as closely as possible, but reduce straight section equally if necessary;
- with minimum bending radius R stated by the manufacturer

Projection sheath(s):

- for lengths ≥ 3 m: 2 bends with 90° in horizontal plane;
- for lengths < 3 m: 1 bend with 90° in horizontal plane;
- with minimum bending radius R stated by the manufacturer

Figure 6 — Test configuration

Bibliography

- [1] ISO 2855, *Radioactive materials — Packagings — Tests for contents leakage and radiation leakage*
- [2] ISO 9000, *Quality management systems — Fundamentals and vocabulary*
- [3] ISO 9001, *Quality management systems — Requirements*
- [4] ISO 9004, *Quality management systems — Guidelines for performance improvements*
- [5] ICRU 51:1993, *Quantities and units in radiation protection dosimetry*

.....

ICS 19.100

Price based on 32 pages