International Standard



3995

INTERNATIONAL ORGANIZATION FOR STANDARDIZATION • МЕЖДУНАРОДНАЯ ОРГАНИЗАЦИЯ ПО СТАНДАРТИЗАЦИИ • ORGANISATION INTERNATIONALE DE NORMALISATION

Metallic powders — Determination of green strength by transverse rupture of rectangular compacts

Poudres métalliques — Détermination de la résistance de comprimés rectangulaires à cru

Second edition — 1985-07-01

UDC 621.762:620.17

Ref. No. ISO 3995-1985 (E)

Descriptors : powder metallurgy, metallic powder, compressed products, tests, determination, green strength, test equipment.

Foreword

ISO (the International Organization for Standardization) is a worldwide federation of national standards bodies (ISO member bodies). The work of preparing International Standards is normally carried out through ISO technical committees. Each member body interested in a subject for which a technical committee has been established has the right to be represented on that committee. International organizations, governmental and non-governmental, in liaison with ISO, also take part in the work.

Draft International Standards adopted by the technical committees are circulated to the member bodies for approval before their acceptance as International Standards by the ISO Council. They are approved in accordance with ISO procedures requiring at least 75 % approval by the member bodies voting.

International Standard ISO 3995 was prepared by Technical Committee ISO/TC 119, *Powder metallurgy*.

ISO 3995 was first published in 1977. This second edition cancels and replaces the first edition, of which it constitutes a minor revision.

Metallic powders — Determination of green strength by transverse rupture of rectangular compacts

1 Scope and field of application

This International Standard specifies a method for the determination of green strength by measuring the transverse rupture strength of compacts of rectangular cross-section.

2 Principle

Subjection of a compact pressed from metallic powder to a uniformly increasing transverse force under controlled conditions until fracture occurs. Determination of the transverse rupture strength, or green strength as used herein, as the stress, calculated from the flexure formula, required to break the compact as a simple beam supported near the ends and applying the force midway between the fixed centre of supports.

The green strength is determined on compacts either having a particular density or after compaction at a specific compacting pressure.

3 Apparatus

3.1 Die, preferably of cemented carbide or alternatively of tool steel, and two punches for producing rectangular test pieces with dimensions according to clause 4. An example of a design for tooling is shown in figure 1.

3.2 Press, capable of applying forces up to about 300 kN with a minimum accuracy of $\pm 2\%$ and adjustable to permit an even increase of the force at a rate no higher than 50 kN/s.

3.3 Balance, capable of weighing the compacts to an accuracy of $\pm 0,01$ g.

3.4 Micrometer or other suitable measuring device, for measuring the dimensions of the compacts to an accuracy of $\pm 0,01$ mm.

3.5 Fixture for testing, having two support cylinders (rollers) with a fixed distance between them and a load cylinder (roller). All three cylinders shall be $3 \pm 0,1$ mm in diameter and

shall be made of hardened steel with a hardness of at least 700 HV, or of hardmetal. The cylinders shall be mounted parallel and the distance between the centres of the support cylinders shall be $25 \pm 0,2$ mm, measured with an accuracy of $\pm 0,1$ mm. The load cylinders shall be mounted midway between the support cylinders.

The mounting of the cylinders shall be such as to account for the permitted deviation from parallelism of the top and bottom faces of the test piece.

A diagrammatic arrangement of a typical test fixture is shown in figure 2.

3.6 Loading device, which may be either of the following:

3.6.1 A compression testing machine capable of determining the breaking force with a minimum accuracy of ± 2 N.

3.6.2 A loading beam apparatus to properly locate the test piece and which is capable of applying a breaking force through a lever arrangement. The applied force can be exerted by various systems, an example of which is given in figure 3. The applied force on the test piece shall be calculated to an accuracy of ± 2 N.

4 Sampling

The quantity of the test sample shall be chosen to give three test pieces with the dimensions 10 to 13 mm wide, at least 30 mm long and 5,5 to 6,5 mm thick. The thickness of the test piece shall be uniform within 0,1 mm over the distance between supports. If necessary, preliminary tests should be made in order to establish the quantity of powder which is needed to fulfil this requirement.

5 Procedure

5.1 Cleaning of the die and punches

Wipe the die cavity and the punches with soft and clean paper towelling soaked with an appropriate solvent such as acetone. Allow the solvent to evaporate.

5.2 Powder testing conditions

5.2.1 Powders which do not contain a lubricant can be compacted in the following ways:

- a) in a dry die (**Warning**: seizure and excessive die wear may occur, particularly at high compacting pressures);
- b) in a die with lubricated walls (see 5.3.1);
- c) after admixing a lubricant (see 5.3.2) and in a dry die.

5.2.2 Powders which contain a lubricant can be compacted in the following ways:

- a) in a dry die;
- b) after admixing additional lubricant (see 5.3.2) and in a dry die.

5.3 Lubrication

Use one of the following methods of lubrication.

5.3.1 Die wall lubrication

Apply to the die walls a mixture or a solution of a lubricant in a volatile liquid, for example 100 g of zinc stearate in 1 000 cm³ of acetone. After any excess liquid has drained away, allow the solution adhering to the walls to evaporate leaving a thin layer of lubricant.

5.3.2 Lubrication of powder

Lubricate the powder to be tested by thoroughly mixing into it a quantity (for example 0,5 to 1,5 %) of a suitable solid lubricant (for example zinc stearate or stearic acid).

5.4 Compacting and ejection

Insert the lower punch into the die cavity. Position the die to the desired filling height by using supporting spacers between the die and the foot of the lower punch. Pour the sample into the die cavity, taking the usual precautions to ensure that the powder is uniformly distributed in the die cavity. Position the upper punch and place the die with the punches between the platens of the press. Apply and release a preliminary force of approximately 20 kN. Remove the spacers supporting the die. If the die is supported by springs, or in some similar way, it is not necessary to apply the preliminary force.

Apply the final force at a constant rate which shall not exceed 50 kN/s.

Eject the compact from the die by means of the lower punch.

The procedure of compacting and ejection is exemplified in figure 4.

5.5 Compacting pressure

Green strength can be determined at a given pressure or density following agreement between supplier and customer. In

the first case the recommended pressure is 400 N/mm². In the second case, when test pieces are pressed to a given density, the maximum deviation between the three test pieces shall not exceed 0,1 g/cm³.

5.6 Determination of density

Measure the length, width and thickness of the test piece in the plane of application of the force to the nearest 0,01 mm. Determine the mass and the volume (calculated from the average value of dimensions).

5.7 Determination of breaking force

Break the test piece under controlled conditions using either a compression testing machine or a loading beam device.

5.7.1 Method 1 — Using a compression testing machine

Position the test piece in the transverse rupture test fixture (see figure 2) so that it is centrally located and perpendicular to the axis of the support cylinders. Place the fixture between the platens of the testing machine and apply a compressive force at a uniform rate such that the test piece fractures within a time not less than 10 s. Record the breaking force to the nearest 2 N.

5.7.2 Method 2 — Using a loading beam device (see figure 3)

Adjust the balance of the beam so that it is level. Position the test piece in the loading beam device so that it is centrally located and perpendicular to the axis of the support cylinders. Increase the load at a uniform rate such that the test piece fractures within a time not less than 10 s.

Determine the input force to the nearest 2 N.

NOTE — When a container and shot are used, the beam shall be balanced with the container in position. The load exerted is then calculated from the mass of the shot only.

6 Expression of results

6.1 Calculate the density of the test piece from its mass and volume. Calculate the arithmetical mean of the determination on three different test pieces to the nearest 0,05 g/cm³.

6.2 The green strength S , expressed in newtons per square millimetre, is given by the formula

$$S = \frac{3 \times P \times L}{2 \times t^2 \times w}$$

where

P is the force, in newtons, required to rupture;

L is the length, in millimetres, of span of the fixture;

t is the thickness, in millimetres, of the test piece;

w is the width, in millimetres, of the test piece.

6.3 Calculate the arithmetical mean of the three determinations rounded to the nearest 0,2 N/mm² for values up to and including 10 N/mm² and to the nearest 0,5 N/mm² for values greater than 10 N/mm².

7 Test report

The test report shall include the following information:

- a) reference to this International Standard;
- b) all details necessary for identification of the test sample;

- c) the type, nature and amount of the lubricant, if it has been added to the powder; in certain cases it may be desirable to report how the lubricant was added;
- d) the density of the test pieces or the compacting pressure;
- e) compacting die material (tool steel or cemented carbide);
- f) the result obtained;
- g) all operations not specified by this International Standard, or regarded as optional;
- h) details of any occurrence which may have affected the result.

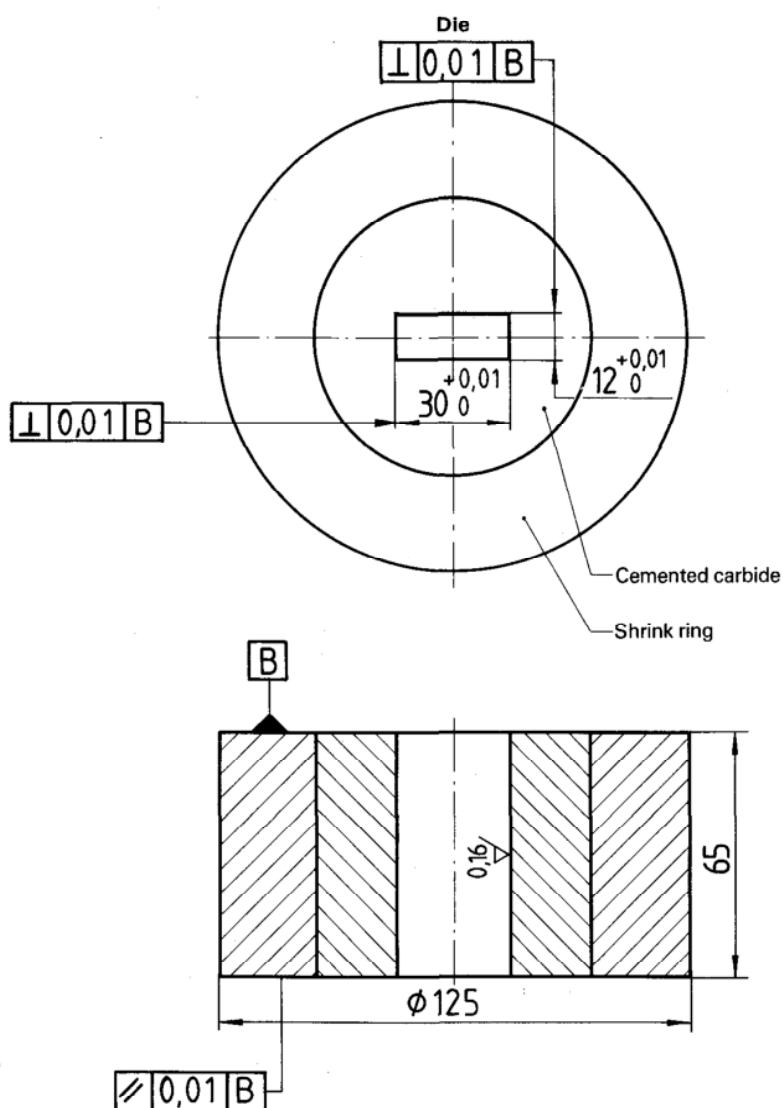

Dimensions in millimetres

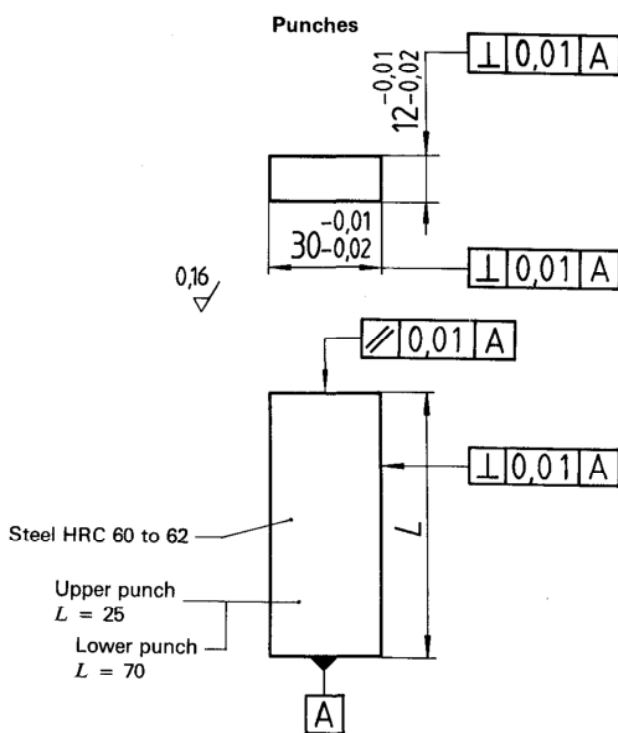

NOTE — Mating parts shall be fitted and lapped.

Figure 1 — Example of tooling to produce a rectangular test piece

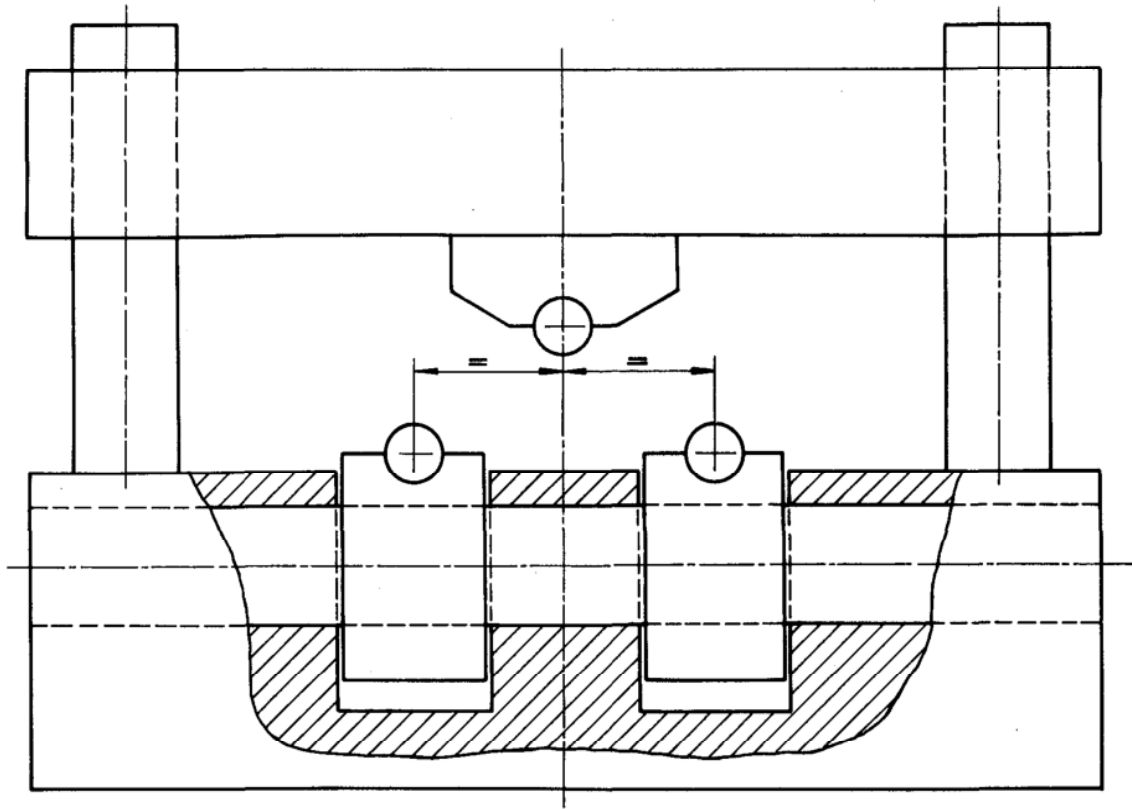

Figure 2 — Diagram of test fixture

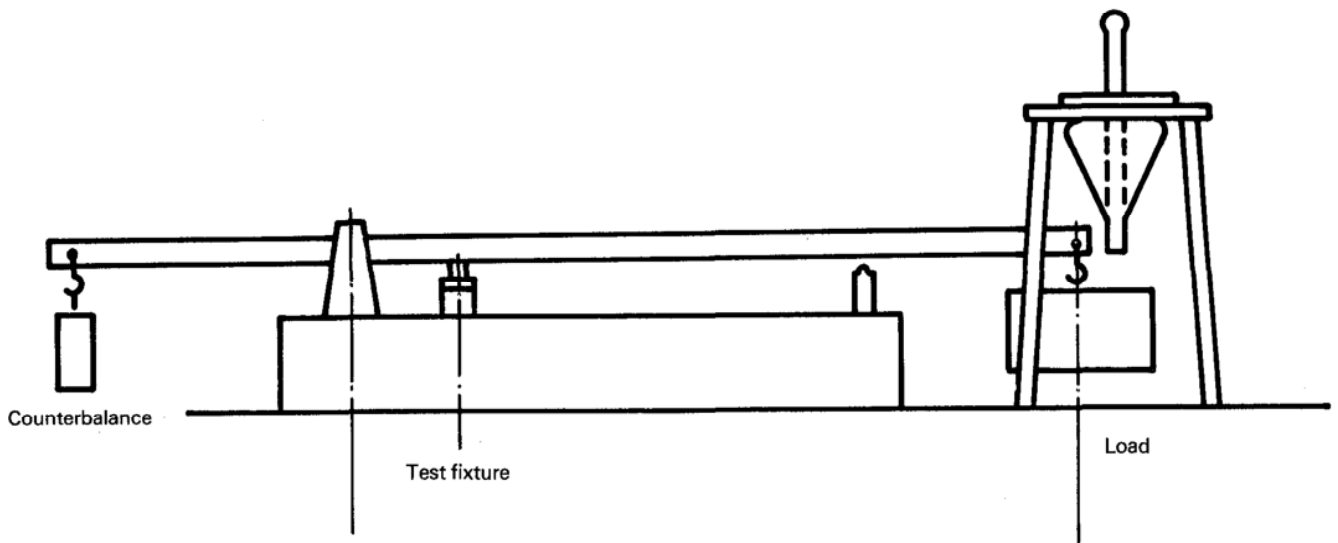

Figure 3 — Example of loading beam apparatus

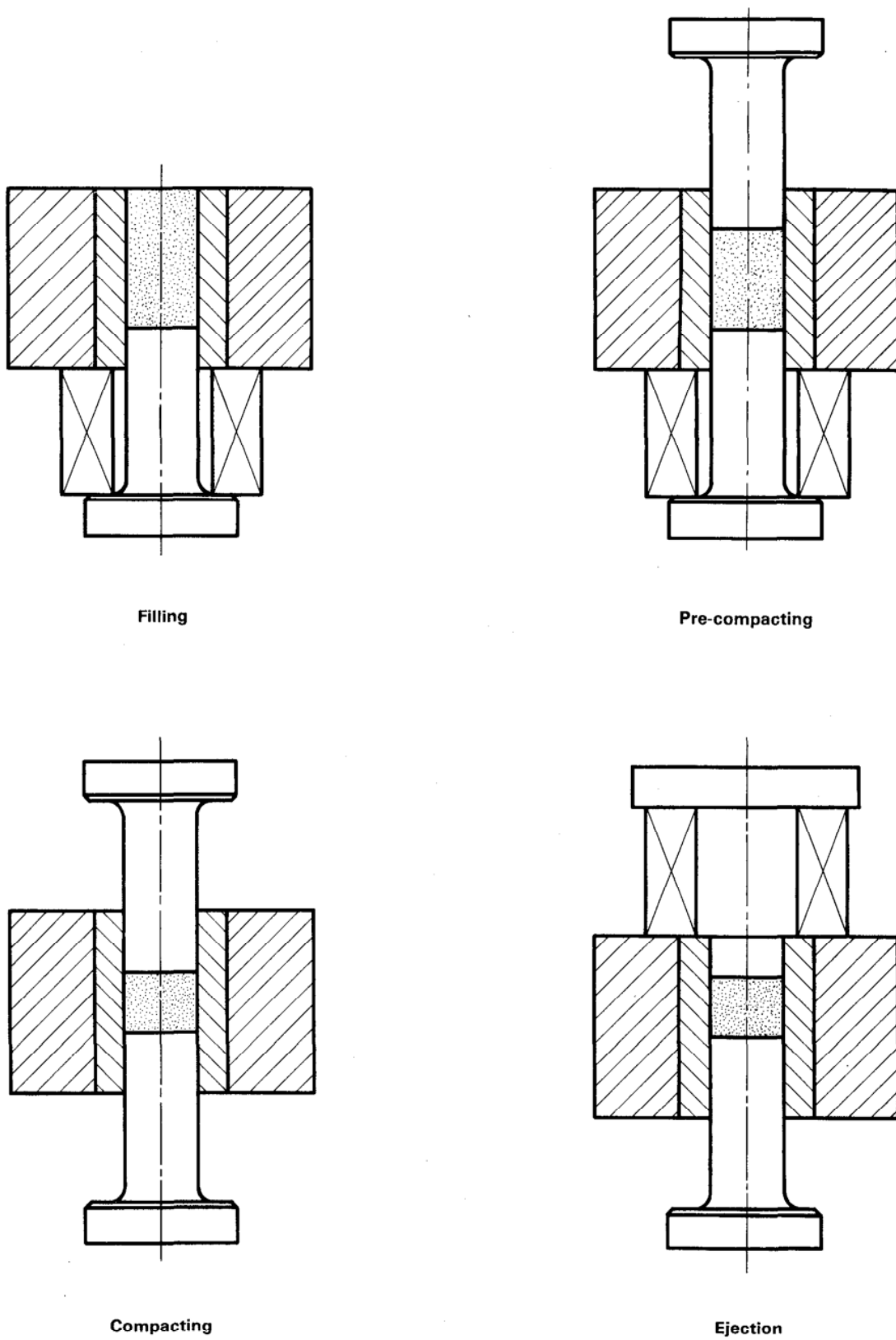

Figure 4 — Procedure of compacting and ejection