

INTERNATIONAL
STANDARD

ISO
3958

Second edition
1996-02-15

**Passenger cars — Driver hand-control
reach**

Voitures particulières — Portée des mains du conducteur



Reference number
ISO 3958:1996(E)

Foreword

ISO (the International Organization for Standardization) is a worldwide federation of national standards bodies (ISO member bodies). The work of preparing International Standards is normally carried out through ISO technical committees. Each member body interested in a subject for which a technical committee has been established has the right to be represented on that committee. International organizations, governmental and non-governmental, in liaison with ISO, also take part in the work. ISO collaborates closely with the International Electrotechnical Commission (IEC) on all matters of electrotechnical standardization.

Draft International Standards adopted by the technical committees are circulated to the member bodies for voting. Publication as an International Standard requires approval by at least 75 % of the member bodies casting a vote.

International Standard ISO 3958 was prepared by Technical Committee ISO/TC 22, *Road vehicles*, Subcommittee SC 13, *Ergonomics applicable to road vehicles*.

This second edition cancels and replaces the first edition (ISO 3958:1977), which has been extended to include tables for hand-reach envelope unrestrained.

Annex A of this International Standard is for information only.

© ISO 1996

All rights reserved. Unless otherwise specified, no part of this publication may be reproduced or utilized in any form or by any means, electronic or mechanical, including photocopying and microfilm, without permission in writing from the publisher.

International Organization for Standardization
Case Postale 56 • CH-1211 Genève 20 • Switzerland

Printed in Switzerland

Introduction

The hand-reach envelopes described in this International Standard were developed using data acquired from test subjects performing reach tasks in test fixtures simulating a range of actual vehicle configurations [1], [2]. The test subjects included equal numbers of men and women selected to represent the driving population on the basis of standing height and age. Subjects were tested with upper torso three-point restraint (a type 1 lap strap and a diagonal non-extending shoulder strap independent of the lap strap), and with only a type 1 lap strap. The data were analysed in a manner to account for different proportions of male and female users.

The hand-reach envelopes are three-dimensional surfaces described in tabular form and can be referenced to a particular vehicle seating configuration according to the procedures described in clauses 4 and 5.

Passenger cars — Driver hand-control reach

1 Scope

1.1 This International Standard defines hand-reach envelopes: the boundaries of passenger car hand-control locations that can be reached by different proportions of male and female driver populations.

This International Standard applies to passenger cars (term 3.1.1 in ISO 3833:1977). It is primarily directed towards the initial design stages of a new vehicle programme. Its application for checking purposes in actual vehicle prototype seat models will take into account the allowable tolerances for the actual H-point and actual torso angle (see ISO/TR 9511).

The hand-reach envelopes apply directly to left-hand-drive passenger cars designed for seated operators in full-width or single-width seats having approximately horizontal fore-and-aft seat adjustment. Application to right-hand-drive vehicles is assumed to be symmetrically opposite.

1.2 The envelopes constructed using the static three-point restraint described in the Introduction are meant to define a restrained reach. The envelopes constructed using lap belt only (type 1) are meant to define an unrestrained reach applicable to all restraint systems with free shoulder movement.

The hand-reach envelopes are directly applicable for a three-finger grasping reach to a forward-mounted control knob of 25 mm diameter manoeuvred horizontally in the fore-and-aft direction. The hand-reach envelopes are also applicable to other types of forward controls by using an appropriate adjustment factor that will account for the mode of operation of the control:

- a) extended-finger-operated forward control: an adjustment factor of 50 mm is added to the values of the reach envelope in the appropriate table;
- b) full-hand-grasped forward control: an adjustment factor of 50 mm is subtracted from the tabled values of the reach envelope.

2 Normative references

The following standards contain provisions which, through reference in this text, constitute provisions of this International Standard. At the time of publication, the editions indicated were valid. All standards are subject to revision, and parties to agreements based on this International Standard are encouraged to investigate the possibility of applying the most recent editions of the standards indicated below. Members of IEC and ISO maintain registers of currently valid International Standards.

ISO 3833:1977, *Road vehicles — Types — Terms and definitions*.

ISO 4130:1978, *Road vehicles — Three-dimensional reference system and fiducial marks — Definitions*.

ISO/TR 9511:1991, *Road vehicles — Driver hand-control reach — In-vehicle checking procedure*.

3 Definitions

For the purposes of this International Standard, the following definitions apply.

3.1 driver hand-reach capability: Maximum reach capability of drivers in a simulated driving situation with the non-reaching hand on the steering-wheel and the right foot on the accelerator pedal.

3.2 basic reach task: Hand-reach to a forward-mounted control with the control held in a three-finger grasp. (See figure 1.)

NOTE 1 This diagram represents a three-finger grasping reach to a 25 mm (\approx 1 in) diameter control knob. All measurements for the hand-reach envelope are referenced to the centre of the control knob face.

3.3 hand-reach envelope: Geometric description of the hand-reach capability for a specified proportion of a driver population and type of torso-restraint system.

3.3.1 restrained reach envelope: Envelope applicable to vehicles using restraint systems with 100 mm of shoulder movement.

3.3.2 unrestrained reach envelope: Envelope applicable to vehicles using restraint systems with free shoulder movement.

3.4 interior dimensions: Characteristics of seating configuration described in terms of the R-point. (See figure 2.)

NOTES

2 The interior dimensions are measured with the front seat in a position according to its R-point location. All adjustable features, such as vertical seat adjustment or seat-back adjustment or an adjustable steering-wheel, are set in the design position according to the manufacturer's specifications. Positions of adjustable features, when not specified by the manufacturer, are the middle of their adjustment range.

3 All interior dimensions shown in figure 2 are measured to the vertical and horizontal body zero planes by setting up

the vehicle relative to the front and rear fiducial mark heights, as specified in ISO 4130, with respect to the vehicle attitude specified by the manufacturer.

3.5 R-point; seating reference point: Manufacturer's design H-point which

- a) establishes the rearmost normal design driving or riding position of each designated seating position that accounts for all modes of adjustment (horizontal, vertical and tilt) that are available for the seat, but does not include seat travel used for purposes other than normal driving and riding;
- b) has coordinates established with respect to the designed vehicle structure;
- c) simulates the position of the pivot centre of the human torso and thigh;
- d) is the reference point employed to position a two-dimensional design layout.

3.6 H-point: Pivot centre of the torso and thigh of the three-dimensional H-point machine used for actual H-point determination, located on the centreplane of the device which is between the H-point sight buttons on either side of the H-point machine. [ISO 6549]

3.7 actual H-point: Pivot centre of the torso line and thigh centreline of the three-dimensional H-point machine using one of the appropriate leg lengths installed in the rearmost normal driving or riding position of the seat as specified by the manufacturer, measured to the H-point sight buttons.

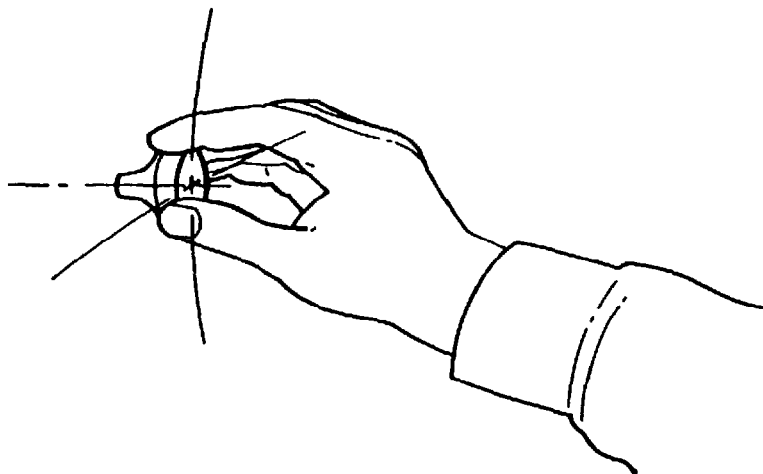

Figure 1 — Three-finger grasping reach

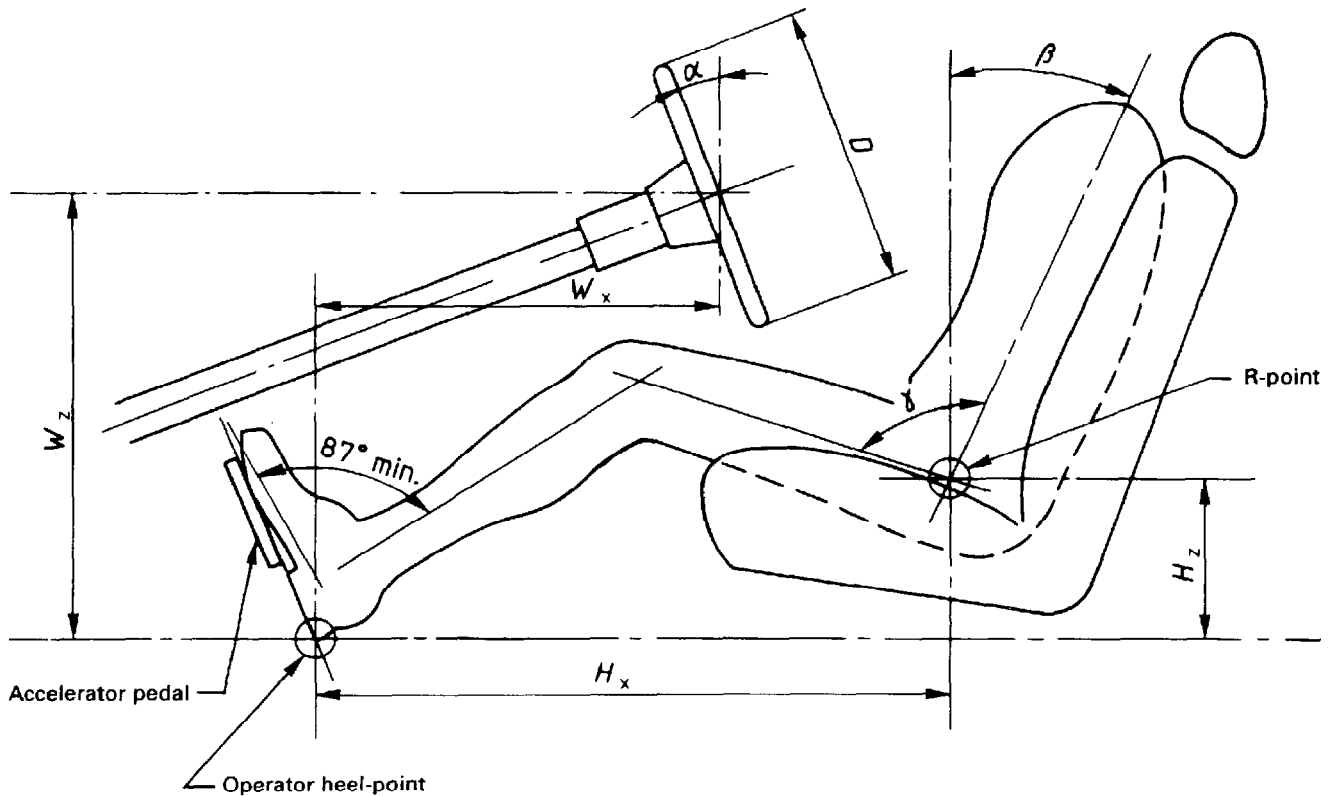

Figure 2 — Vehicle seating configuration

3.8 torso line: Centreline of the headroom probe in its fully rearward position against the back pan of the three-dimensional H-point machine.

3.9 design torso angle, β : Angle measured between a true vertical line through the R-point or seating reference point and the torso line on a two-dimensional design layout.

3.10 actual torso angle: Angle measured from a true vertical line through the actual H-point using the back angle quadrant on the three-dimensional H-point machine and the headroom probe in the fully rearward position.

3.11 operator heel-point: Intersection of the right heel of the three-dimensional H-point machine with the surface of the depressed floor covering or other heel support.

NOTE 4 When 95th percentile leg elements are used, the shoe sole of the device touches, and is allowed to depress, the accelerator pedal through some portion of its travel as specified by the manufacturer. When 50th percentile leg elements are used, the shoe sole of the device does not contact the accelerator pedal and both feet are allowed to take natural positions on the floor with the legs extended: in this case, the heel-point is as defined by the manufac-

turer. The seat is located according to its R-point (seating reference point) location.

3.12 foot angle: Angle measured between the lower leg centreline and a line tangential to the bottom of the bare right foot.

NOTE 5 The foot angle is restricted to not less than 87°. A scale on the foot assembly of the three-dimensional H-point machine indicates the foot angle. The angle to the bottom of the device's shoe is 6,5° less than the bare foot angle because of the shoe sole and heel thickness.

3.13 hip angle, γ : Angle, in degrees, between the torso line and the thigh centreline.

3.14 horizontal R-point to heel-point, H_x : Horizontal dimension from the R-point to the operator heel-point.

3.15 vertical R-point to heel-point, H_z : Vertical dimension from the R-point to the operator heel-point.

3.16 horizontal seat track travel: Horizontal dimension between the R-point and the foremost normal design driving or riding position.

3.17 steering-wheel diameter, D : Maximum outside diameter of the steering-wheel.

NOTE 6 If the steering-wheel is not round, assume twice the largest swept radius.

3.18 steering-wheel angle α : Angle, in degrees, that the steering-wheel surface plane makes with the vertical.

3.19 horizontal wheel-centre to heel-point W_x : Distance from the operator heel-point to the centre of the steering-wheel in the plane tangent to the steering-wheel rim.

3.20 vertical wheel-centre to heel-point W_z : Distance from the operator heel-point to the centre of the steering-wheel in the plane tangent to the steering-wheel rim.

3.21 centreplane of operator; C/PO: Y-coordinate of the R-point or actual H-point.

NOTE 7 This represents the centreplane of the operator or of the three-dimensional H-point machine. In vehicles with individual seats, the centreplane of the seat represents the centreplane of the operator. On other seats, the centreplane of the operator is specified by the manufacturer.

3.22 general package factor, G : Single index value resulting from an algebraic equation that expresses, in summarized form, the geometry of a particular vehicle seating configuration.

NOTE 8 G is a synthesized variable that provides a quantitative index of a vehicle's workspace geometry. The G -value for a vehicle can be calculated by substituting the principal package dimensions describing the vehicle seating configuration as shown in figure 2 into the following equation (for computations where lengths are expressed in millimetres and angles in degrees):

$$G = 0,0018H_z - 0,0197\beta + 0,0027D + 0,0106\alpha - 0,0011W_x + 0,0024W_z + 0,0027\gamma - 3,0853$$

3.23 hand-reach reference plane; HR plane: Vertical reference plane extending laterally across the vehicle.

NOTE 9 It is used to position the hand-reach envelopes with respect to the geometry of the vehicle seating configuration. The horizontal location of the HR plane rearward of the operator heel-point is determined by application of the general package factor G . (See 4.4.)

4 Requirements

4.1 The following list establishes the ranges of the operator workspace dimensions for which these envelopes apply. Application to vehicles whose dimen-

sions are outside these ranges shall be made with the necessary corrections:

Torso angle, β	9° to 33°
Vertical R-point to heel-point, H_z	130 mm to 520 mm
Horizontal seat track travel	130 mm min.
Steering-wheel diameter, D	330 mm to 600 mm
Steering-wheel angle, α	10° to 70°
Wheel centre to heel-point, horizontal, W_x	152 mm to 660 mm
Wheel centre to heel-point, vertical, W_z	530 mm to 838 mm

4.2 The envelopes describe the boundaries of control locations that can be reached by at least 95 % of certain driver populations that include mixtures of 50/50, 75/25 and 90/10 male/female driver population ratios. The envelopes for each of these categories are located in relation to specified reference planes. The envelopes extend from 400 mm outboard to 600 mm inboard of the operator centreplane and from 100 mm below the R-point or actual H-point to 800 mm above the R-point or actual H-point (see figure 3). Information concerning controls located not more than 130 mm outside this region may be extrapolated from the tables using, for example, conventional graphical or analytical methods which take account of the curvature and shape of the envelope.

4.3 Hand-reach envelopes are specified in tables 1 to 42 for restrained and unrestrained reach, for seven different seating configurations and for three male/female driver population ratios. The selection of an envelope for a vehicle is based on the type of reach (restrained or unrestrained), the calculated value of the general package factor, G , and the identification of the male/female driver population ratio appropriate for the vehicle.

4.4 The hand-reach envelope is located in the vehicle by selecting a relationship that uses the value of the general package factor, G . The horizontal component of a point on the reach envelope is measured as the distance forward of a hand-reach reference plane, HR (see 3.23). The location of this plane is measured rearward from the operator heel-point, determined in millimetres, and is calculated using the general package factor, G , from the formula:

$$HR = 786 - 99G$$

NOTE 10 The dimension HR is not the dimension from the H-point to the R-point.

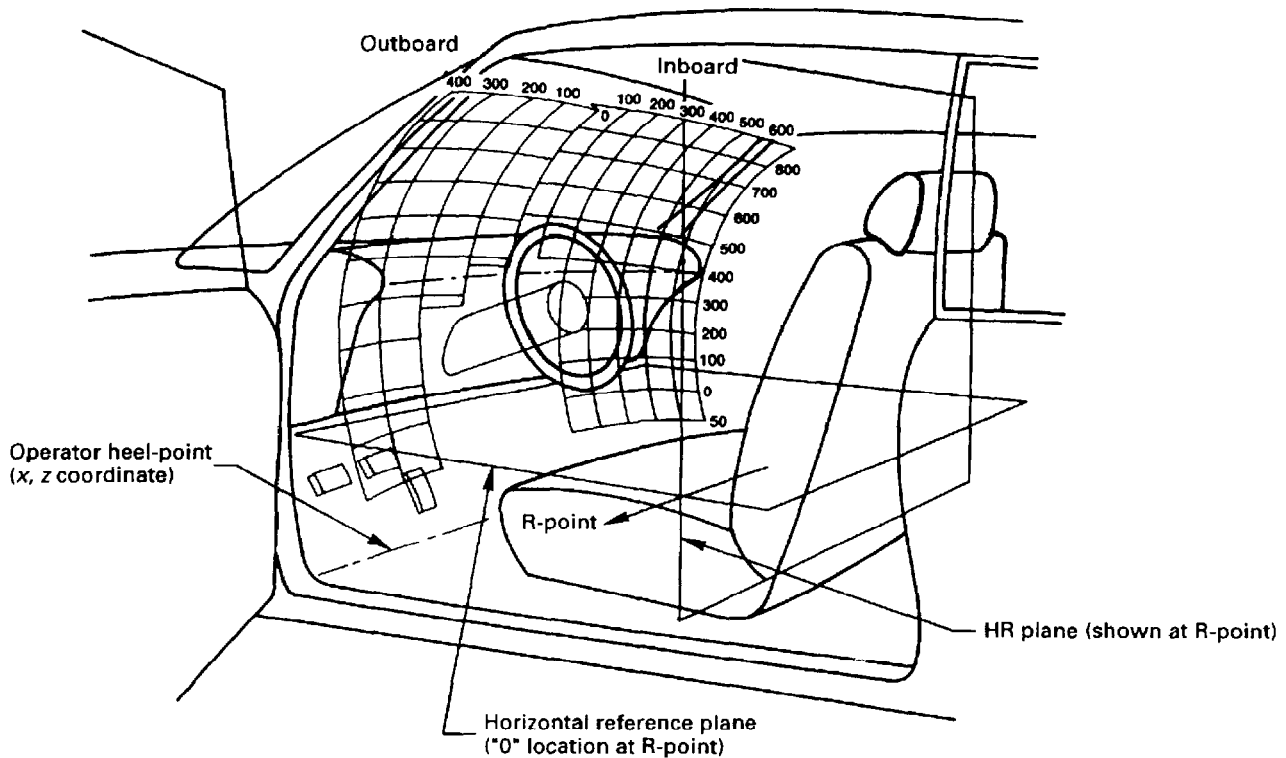

Figure 3 — Hand-reach envelope in vehicle position

5 Procedure for using hand-reach envelopes

5.1 Reference planes

The envelopes are located in the vehicle according to a set of orthogonal reference planes¹⁾: a horizontal elevation reference plane through the R-point, the HR plane, and a vertical plane extending along the C/PO and parallel to the plane of symmetry of the vehicle.

5.2 Establishment of reference origin

5.2.1 Specify the dimensions describing the geometry of the vehicle seating configuration and calculate the value of the general package factor, G , as defined in 3.22.

5.2.2 Calculate HR from the value of the general package factor, G , as specified in 4.4. Determine the longitudinal location of the hand-reach reference plane.

— If $(HR - H_x)$ is less than zero, the hand-reach reference plane is located longitudinally at a distance HR rearward of the operator heel-point.

— If $(HR - H_x)$ is greater than zero, the hand-reach reference plane is located longitudinally at the R-point location.

5.3 Identification of appropriate hand-reach envelope

5.3.1 Referring to tables 1 to 42, identify the hand-reach envelope appropriate for the value of the general package factor, G , calculated for this vehicle and the specified driver population.

5.3.2 The blank areas in the hand-reach tables are regions where hand-reach was not measured or where design limit values could not be established. The areas underlined are regions where the difference between the hand-reach model and the observed design values exceed 25 mm. The hand-reach values shown in these areas should be used with caution.

1) The reference planes are defined as planes perpendicular to the three-dimensional reference system (see ISO 4130).

5.4 Determination control is within reach

5.4.1 Determine the lateral locations of the controls of interest. These locations are described as lateral locations from the C/PO. Determine the height of the control above the horizontal elevation reference plane specified in 5.1.

5.4.2 The limiting value of reach can be read from the appropriate table at the designated elevation and station location. Interpolation may be required if the necessary locations are not included in the table. In-

terpolate laterally first before interpolating vertically. Curvilinear interpolations should be made using two locations on either side of the desired control.

5.4.3 The contour of the hand-reach envelope refers to the geometric centre of the control knob face. If the control knob face is at, or rearward of, the contour, it is estimated that at least the specified proportion of the indicated driver population can reach and operate the control.

Table 1 — Hand-reach envelope restrained — Vehicle range ($G < - 1,25$) — Population mix: 50/50 males/females

Dimensions in millimetres

Elevation above/below R-point	Stations outboard of C/PO							Stations inboard of C/PO								
	400	300	250	200	100	50	0	0	50	100	200	250	300	400	500	600
800	387	438	456	470	490	497	502	493	501	504	495	483	468	<u>426</u>	<u>377</u>	
700	463	506	520	531	546	551	556	550	562	566	557	546	532	<u>499</u>	<u>455</u>	
600	519	555	567	576	586	<u>586</u>	<u>584</u>	<u>590</u>	<u>605</u>	611	604	595	584	555	514	449
500	556	586	598	606	609	<u>603</u>	<u>589</u>	<u>614</u>	<u>630</u>	638	637	631	622	595	553	486
450	567	595	607	615	615	<u>604</u>	<u>583</u>	<u>620</u>	<u>636</u>	645	649	644	636	609	565	498
400	574	600	612	621	618	601	571	621	637	648	656	654	646	619	572	506
350	576	601	614	623	616	594	555	619	633	646	660	660	654	625	574	511
300	574	597	612	622	611					<u>639</u>	660	662	658	626	572	510
250	567	590	605	617	602					<u>628</u>	657	662	658	624	564	506
200	557	578	596	608	590					<u>613</u>	649	658	656	618	551	498
100	524	544	566	581							624	639	640	593	510	469
0	474										584	607	610	551	449	<u>423</u>
- 100	410										528	561	567	493	367	<u>360</u>

Table 2 — Hand-reach envelope restrained — Vehicle range ($G < - 1,25$) — Population mix: 75/25 males/females

Dimensions in millimetres

Elevation above/below R-point	Stations outboard of C/PO							Stations inboard of C/PO								
	400	300	250	200	100	50	0	0	50	100	200	250	300	400	500	600
800	422	470	488	501	520	526	532	530	539	542	532	520	505	466	419	
700	496	536	550	560	574	579	584	582	595	600	590	580	567	534	492	
600	550	584	596	604	612	<u>612</u>	<u>609</u>	<u>619</u>	<u>634</u>	640	634	626	615	586	545	480
500	584	614	625	633	634	<u>625</u>	<u>610</u>	<u>638</u>	<u>654</u>	663	664	658	649	622	580	513
450	594	622	634	641	639	<u>625</u>	<u>602</u>	<u>642</u>	<u>658</u>	668	673	670	662	634	589	523
400	600	626	639	647	640	620	587	642	657	668	679	678	671	642	594	529
350	601	627	640	648	637	611	568	637	651	664	681	682	677	646	594	531
300	598	623	637	646	631					<u>656</u>	680	683	679	646	589	529
250	591	615	630	641	621					<u>643</u>	675	681	678	642	578	523
200	579	603	620	632	607					<u>625</u>	666	675	673	633	563	513
100	544	568	590	604							637	654	654	604	517	480
0	492										593	618	621	558	451	430
- 100	426										534	569	575	496	364	363

Table 3 — Hand-reach envelope restrained — Vehicle range ($G < - 1,25$) — Population mix: 90/10 males/females

Dimensions in millimetres

Elevation above/below R-point	Stations outboard of C/PO							Stations inboard of C/PO								
	400	300	250	200	100	50	0	0	50	100	200	250	300	400	500	600
800	443	490	507	519	538	544	550	551	561	564	554	542	527	489	443	
700	516	555	568	578	591	596	600	601	615	619	610	600	587	555	513	
600	568	601	613	621	628	627	624	<u>635</u>	<u>651</u>	657	652	644	633	605	564	498
500	601	630	641	649	648	639	622	<u>653</u>	<u>669</u>	678	680	674	666	639	595	528
450	611	638	650	657	653	638	612	<u>655</u>	<u>671</u>	681	688	685	677	649	604	537
400	616	642	654	662	653	<u>632</u>	<u>597</u>	654	668	680	693	692	685	656	607	542
350	616	642	655	663	649	<u>621</u>	<u>575</u>	648	661	675	694	695	690	659	605	543
300	613	638	652	661	642					<u>665</u>	691	695	691	657	598	540
250	605	630	645	655	631					<u>651</u>	685	692	689	652	587	533
200	592	618	635	646	617					<u>632</u>	675	685	684	642	570	521
100	556	583	604	617							644	662	662	611	521	486
0	503										598	624	627	562	451	434
- 100	436										537	573	579	497	361	365

Table 4 — Hand-reach envelope restrained — Vehicle range ($-1,25 \leq G < -0,75$) — Population mix: 50/50 males/females

Dimensions in millimetres

Elevation above/below R-point	Stations outboard of C/PO							Stations inboard of C/PO								
	400	300	250	200	100	50	0	0	50	100	200	250	300	400	500	600
800	391	441	460	474	494	501	507	500	509	512	502	491	475	<u>435</u>	<u>386</u>	
700	466	509	523	535	550	555	560	556	569	573	564	553	540	<u>507</u>	<u>464</u>	
600	521	558	570	579	589	<u>590</u>	<u>589</u>	<u>595</u>	<u>611</u>	617	611	602	591	562	521	456
500	558	589	600	609	613	<u>606</u>	<u>594</u>	<u>618</u>	<u>635</u>	643	644	638	629	602	559	492
450	569	597	609	618	619	<u>608</u>	<u>588</u>	<u>624</u>	<u>640</u>	649	654	650	643	615	571	504
400	576	602	615	623	621	605	577	625	640	651	661	660	653	625	577	512
350	578	602	616	625	620	598	560	622	636	649	665	665	660	630	579	516
300	576	599	613	624	615					<u>641</u>	665	668	663	631	575	515
250	569	591	607	618	606					<u>630</u>	661	667	664	629	567	510
200	559	580	597	610	594					<u>614</u>	653	662	660	622	553	502
100	525	545	566	582							627	643	644	596	511	471
0	476										586	611	614	554	449	<u>425</u>
- 100	411										530	564	570	495	367	<u>362</u>

Table 5 — Hand-reach envelope restrained — Vehicle range ($-1,25 \leq G < -0,75$) — Population mix: 75/25 males/females

Dimensions in millimetres

Elevation above/below R-point	Stations outboard of C/PO							Stations inboard of C/PO								
	400	300	250	200	100	50	0	0	50	100	200	250	300	400	500	600
800	427	475	493	506	525	532	538	536	546	549	539	527	512	474	426	
700	500	541	555	565	579	584	589	588	602	606	597	587	574	542	499	
600	553	588	600	608	617	<u>617</u>	<u>615</u>	<u>624</u>	<u>640</u>	646	641	633	622	594	553	487
500	587	617	628	636	638	<u>631</u>	<u>616</u>	<u>644</u>	<u>660</u>	669	670	665	657	629	586	519
450	597	625	637	645	643	<u>631</u>	<u>606</u>	<u>647</u>	<u>663</u>	673	680	676	669	641	596	529
400	603	629	641	650	645	626	595	646	661	673	685	684	678	649	600	535
350	604	629	642	651	642	617	576	641	655	668	687	688	683	652	599	537
300	601	625	639	649	636					<u>659</u>	685	689	685	652	593	535
250	593	617	632	643	626					<u>646</u>	680	687	684	647	583	528
200	582	605	622	634	612					<u>628</u>	671	681	679	639	567	518
100	546	569	591	606							641	659	660	609	521	484
0	494										597	623	627	563	454	435
- 100	427										538	574	580	500	367	368

Table 6 — Hand-reach envelope restrained — Vehicle range ($-1,25 \leq G < -0,75$) — Population mix: 90/10 males/females

Dimensions in millimetres

Elevation above/below R-point	Stations outboard of C/PO							Stations inboard of C/PO								
	400	300	250	200	100	50	0	0	50	100	200	250	300	400	500	600
800	448	496	513	526	544	551	557	557	567	570	560	549	534	496	450	
700	520	560	573	583	597	602	606	608	621	626	617	607	594	562	520	
600	572	606	617	626	633	633	630	<u>641</u>	<u>657</u>	663	659	651	640	612	571	504
500	605	634	645	653	654	645	630	<u>658</u>	<u>674</u>	683	686	681	673	646	602	535
450	614	642	653	661	658	644	620	<u>661</u>	<u>676</u>	687	694	692	684	656	610	544
400	619	646	658	665	658	<u>639</u>	<u>605</u>	659	673	686	699	698	692	663	613	549
350	620	645	658	666	655	<u>629</u>	<u>585</u>	653	666	680	700	702	697	665	611	550
300	616	641	655	664	648					<u>670</u>	697	702	698	664	604	546
250	608	632	648	658	637					<u>655</u>	691	699	696	658	592	539
200	595	620	637	648	623					<u>636</u>	681	692	690	648	575	527
100	558	584	605	619							650	668	669	616	526	492
0	505										604	630	634	568	456	440
- 100	437										543	579	585	503	366	371

Table 7 — Hand-reach envelope restrained — Vehicle range ($- 0,75 \leq G < - 0,25$) — Population mix: 50/50 males/females

Dimensions in millimetres

Horizontal reach: forward of the HR reference plane at stations located laterally from the centreplane of operator (C/PO) and at elevations above and below the R-point or actual H-point. The envelope describes a 95 % level of performance of a driver population composed of 50 % male and 50 % female drivers wearing three-point static restraint.

Elevation above/below R-point	Stations outboard of C/PO							Stations inboard of C/PO								
	400	300	250	200	100	50	0	0	50	100	200	250	300	400	500	600
800	394	445	464	478	498	505	511	507	516	519	510	498	483	443	395	
700	469	512	527	538	553	559	564	562	576	580	571	561	548	515	472	
600	524	560	573	583	593	594	593	601	617	623	618	610	599	570	529	463
500	560	591	603	612	616	610	598	623	639	648	650	644	636	609	566	498
450	571	600	612	621	622	612	593	628	643	654	660	657	649	622	576	510
400	578	604	617	626	624					655	667	666	659	631	582	517
350	580	604	618	627	623					652	670	671	666	636	583	520
300	578	601	615	626	618					644	669	673	669	636	579	519
250	571	593	608	620	609					632	665	672	669	633	569	514
200	561	581	598	611	597					615	657	667	665	626	555	505
100	527	545	566	583							630	647	648	599	512	474
0	478	494	521	542							588	614	618	556	450	
- 100	412	429	461	487							532	567	574	497	368	

Table 8 — Hand-reach envelope restrained — Vehicle range ($-0,75 \leq G < -0,25$) — Population mix: 75/25 males/females

Dimensions in millimetres

Elevation above/below R-point	Stations outboard of C/PO							Stations inboard of C/PO								
	400	300	250	200	100	50	0	0	50	100	200	250	300	400	500	600
800	431	480	498	512	531	538	544	543	552	556	546	534	519	481	434	
700	504	545	559	570	584	590	594	595	608	613	604	594	581	549	507	
600	556	591	604	613	622	622	620	630	646	653	648	640	629	601	560	493
500	590	620	632	640	643	636	622	649	665	674	677	672	664	636	593	525
450	600	628	640	648	648	636	615	652	667	678	686	683	676	648	602	535
400	606	632	644	653	649					677	691	690	684	655	605	541
350	607	632	645	654	647					673	693	695	690	658	604	543
300	604	627	642	652	640					663	690	695	692	658	598	540
250	596	619	635	646	631					649	685	693	690	653	587	534
200	584	606	624	636	617					631	675	687	685	644	571	523
100	548	570	591	607						646	664	665	614	524	489	
0	496	518	545	565						601	628	632	567	457		
-100	428	451	484	509						543	579	585	505	371		

Table 9 — Hand-reach envelope restrained — Vehicle range ($-0,75 \leq G < -0,25$) — Population mix: 90/10 males/females

Dimensions in millimetres

Elevation above/below R-point	Stations outboard of C/PO							Stations inboard of C/PO								
	400	300	250	200	100	50	0	0	50	100	200	250	300	400	500	600
800	<u>454</u>	501	519	532	551	557	563	564	574	577	567	556	541	503	457	
700	<u>584</u>	565	578	589	603	608	613	614	628	632	624	614	601	570	528	
600	575	610	622	630	639	639	637	647	663	670	666	658	647	619	578	511
500	608	638	649	657	659	651	637	664	680	689	693	688	680	653	609	541
450	617	645	657	665	663	651	628	666	681	692	701	698	691	663	616	550
400	622	649	661	669	<u>664</u>					691	705	705	699	670	619	555
350	623	648	661	670	<u>661</u>					685	706	708	704	672	617	556
300	619	643	657	667	654					674	703	708	705	670	609	552
250	611	634	650	661	643					660	697	705	703	664	597	545
200	598	622	639	651	629					640	686	698	697	654	580	533
100	561	585	606	621							655	674	675	622	530	498
0	507	532	559	578							609	637	640	574	461	
-100	438	465	498	522							548	586	592	509	372	

Table 10 — Hand-reach envelope restrained — Vehicle range ($- 0,25 \leq G < + 0,25$) — Population mix: 50/50 males/females

Dimensions in millimetres

Elevation above/below R-point	Stations outboard of C/PO							Stations inboard of C/PO								
	400	300	250	200	100	50	0	0	50	100	200	250	300	400	500	600
800	397	449	467	482	503	510	516	514	524	527	517	506	491	452	403	
700	472	515	530	542	557	563	568	569	583	588	579	568	555	523	480	
600	526	563	576	586	596	597	596	606	623	629	625	617	606	578	536	470
500	562	593	605	614	619	614	603	627	644	653	656	651	643	616	572	505
450	573	602	614	623	625	616	597	632	647	658	666	663	656	628	582	516
400	580	606	619	628	628					658	672	672	666	637	587	523
350	582	606	620	630	626					654	675	677	672	641	587	525
300	580	602	617	627	621					646	673	678	675	641	582	524
250	573	594	610	622	613					633	669	677	674	637	572	518
200	563	582	599	613	601					616	660	671	670	629	557	509
100	529	546	567	584							632	651	652	602	513	477
0	479	494	520	542							590	617	621	558	450	
- 100	414	427	460	487							534	570	577	499	368	

Table 11 — Hand-reach envelope restrained — Vehicle range ($- 0,25 \leq G < + 0,25$) — Population mix: 75/25 males/females

Dimensions in millimetres

Elevation above/below R-point	Stations outboard of C/PO							Stations inboard of C/PO								
	400	300	250	200	100	50	0	0	50	100	200	250	300	400	500	600
800	436	485	503	517	537	544	549	549	559	563	553	541	527	489	442	
700	507	549	564	575	589	595	600	601	615	620	611	601	588	557	515	
600	559	595	608	617	626	627	626	636	652	659	655	647	637	609	567	500
500	593	624	635	644	647	641	629	654	670	679	683	679	671	643	599	532
450	603	631	643	652	652	642	622	657	672	683	692	690	683	655	607	542
400	608	635	647	656	654					682	697	697	691	662	611	547
350	610	634	648	657	651					677	698	701	696	665	609	548
300	606	630	644	654	645					667	696	701	698	663	603	546
250	599	621	637	648	635					653	690	698	696	658	591	539
200	587	608	625	638	622					634	680	692	691	649	575	528
100	551	571	592	608							650	669	671	618	527	494
0	498	518	544	565							606	633	637	572	460	
- 100	430	449	483	508							547	584	591	509	374	

Table 12 — Hand-reach envelope restrained — Vehicle range ($- 0,25 \leq G < + 0,25$) — Population mix: 90/10 males/females

Dimensions in millimetres

Elevation above/below R-point	Stations outboard of C/PO							Stations inboard of C/PO								
	400	300	250	200	100	50	0	0	50	100	200	250	300	400	500	600
800	<u>459</u>	507	524	538	557	564	570	570	581	584	574	562	548	511	464	
700	<u>528</u>	569	584	594	609	614	619	620	634	639	631	621	608	577	535	
600	579	614	626	635	644	645	643	653	669	676	672	665	655	627	585	518
500	611	642	653	661	664	657	644	669	685	695	699	695	687	660	615	548
450	621	649	661	669	669	657	636	671	686	698	707	705	698	670	623	557
400	626	652	664	673	<u>669</u>					696	712	712	706	676	625	562
350	626	651	664	673	<u>666</u>					690	712	715	711	678	622	562
300	622	646	660	670	659					679	709	715	712	676	615	559
250	614	637	653	664	649					664	702	711	709	670	602	551
200	601	624	641	653	634					644	692	704	703	660	585	539
100	564	585	607	623							661	680	682	628	535	504
0	510	532	559	579							615	643	647	579	466	
- 100	439	463	496	521							554	592	598	515	378	

Table 13 — Hand-reach envelope restrained — Vehicle range ($+ 0,25 \leq G < + 0,75$) — Population mix: 50/50 males/females

Dimensions in millimetres

Elevation above/below R-point	Stations outboard of C/PO							Stations inboard of C/PO								
	400	300	250	200	100	50	0	0	50	100	200	250	300	400	500	600
800	401	453	471	486	507	514	520	521	531	535	525	513	498	460	412	
700	474	518	534	545	561	567	572	575	590	595	586	576	563	531	489	
600	529	566	579	589	599	601	600	612	628	635	632	624	614	585	544	476
500	564	596	608	617	623	618	607	632	648	658	662	658	650	622	578	511
450	575	604	616	626	629	620	602	635	651	662	671	669	663	634	587	521
400	582	608	621	630	631					662	677	678	672	642	592	528
350	584	608	622	632	629					657	679	682	678	646	591	530
300	582	604	618	629	624					648	678	683	680	646	585	528
250	576	595	611	624	616					635	672	681	679	642	575	522
200	565	583	600	614	604					617	664	676	675	633	559	512
100	531	546	567	585							635	655	657	605	515	480
0	481	494	520	542							593	621	625	561	451	
- 100	415	426	458	486							536	573	581	501	369	

Table 14 — Hand-reach envelope restrained — Vehicle range ($+ 0,25 \leq G < + 0,75$) — Population mix: 75/25 males/females

Dimensions in millimetres

Horizontal reach: forward of the HR reference plane at stations located laterally from the centreplane of operator (C/PO) and at elevations above and below the R-point or actual H-point. The envelope describes a 95 % level of performance of a driver population composed of 75 % male and 25 % female drivers wearing three-point static restraint.

Elevation above/below R-point	Stations outboard of C/PO							Stations inboard of C/PO								
	400	300	250	200	100	50	0	0	50	100	200	250	300	400	500	600
800	440	490	508	522	542	549	555	555	566	570	560	548	534	496	449	
700	511	553	568	579	594	600	605	607	621	627	618	608	596	565	522	
600	562	599	611	621	631	632	631	641	657	665	662	654	644	616	574	507
500	596	627	639	647	652	646	635	659	675	685	690	686	678	650	605	538
450	606	634	646	655	657	647	628	661	676	688	698	696	690	661	613	548
400	611	638	650	659	656					686	703	703	698	668	616	553
350	612	637	650	660	656					681	704	707	703	671	614	554
300	609	632	646	657	650					670	701	707	704	669	607	551
250	602	623	639	650	640					656	695	704	702	664	595	544
200	590	610	627	640	626					637	685	698	697	654	579	533
100	553	571	593	610							655	675	677	623	531	499
0	500	517	544	565							610	638	643	576	464	
- 100	431	448	481	508							551	589	596	514	378	

Table 15 — Hand-reach envelope restrained — Vehicle range ($+ 0,25 \leq G < + 0,75$) — Population mix: 90/10 males/females

Dimensions in millimetres

Elevation above/below R-point	Stations outboard of C/PO							Stations inboard of C/PO								
	400	300	250	200	100	50	0	0	50	100	200	250	300	400	500	600
800	<u>464</u>	513	530	544	564	570	576	576	587	591	581	569	555	518	471	
700	<u>532</u>	574	589	599	614	620	624	626	640	646	638	628	615	584	542	
600	583	618	631	640	649	650	649	659	675	682	679	672	662	634	592	525
500	615	645	657	665	669	663	651	675	691	701	706	702	694	667	622	555
450	624	652	664	673	674	663	644	677	691	703	714	712	706	677	629	563
400	629	655	668	677	<u>674</u>					701	718	719	713	683	631	568
350	629	654	667	677	<u>671</u>					695	718	722	718	685	628	568
300	625	649	663	673	664					684	715	722	718	683	620	565
250	617	639	655	666	654					668	708	718	716	677	608	557
200	605	626	643	656	640					649	698	711	710	666	590	545
100	567	586	608	624						666	687	688	634	540	509	
0	512	531	558	579						620	649	653	585	471		
- 100	441	461	494	521						560	598	605	521	383		

Table 16 — Hand-reach envelope restrained — Vehicle range ($+ 0,75 \leq G < + 1,25$) — Population mix: 50/50 males/females

Dimensions in millimetres

Elevation above/below R-point	Stations outboard of C/PO							Stations inboard of C/PO								
	400	300	250	200	100	50	0	0	50	100	200	250	300	400	500	600
800	404	456	475	490	511	518	524	528	539	543	533	521	506	469	421	
700	477	521	537	549	565	570	575	581	596	602	594	584	571	540	497	
600	531	569	582	592	603	<u>605</u>	<u>604</u>	<u>617</u>	<u>634</u>	641	639	631	621	593	551	483
500	566	598	610	620	626	<u>621</u>	<u>611</u>	<u>636</u>	<u>652</u>	662	668	664	657	629	584	517
450	577	606	619	628	632	<u>623</u>	<u>607</u>	<u>639</u>	<u>654</u>	666	677	676	669	641	593	527
400	584	610	623	633	634					665	682	683	678	648	596	533
350	586	610	623	634	633					660	684	688	684	651	595	535
300	584	605	620	631						650	<u>682</u>	<u>689</u>	<u>686</u>	651	589	533
250	578	597	613	625						636	<u>676</u>	<u>686</u>	<u>685</u>	646	577	526
200	567	584	601	616						618	<u>667</u>	<u>680</u>	<u>680</u>	637	562	516
100	533	547	568	586							638	659	661	608	516	483
0	483	493	519	542							595	624	629	563	452	435
- 100	416	424	457	485							539	577	584	503	370	372

Table 17 — Hand-reach envelope restrained — Vehicle range ($+ 0,75 \leq G < + 1,25$) — Population mix: 75/25 males/females

Dimensions in millimetres

Horizontal reach: forward of the HR reference plane at stations located laterally from the centreplane of operator (C/PO) and at elevations above and below the R-point or actual H-point. The envelope describes a 95 % level of performance of a driver population composed of 75 % male and 25 % female drivers wearing three-point static restraint.

Elevation above/below R-point	Stations outboard of C/PO							Stations inboard of C/PO								
	400	300	250	200	100	50	0	0	50	100	200	250	300	400	500	600
800	445	495	513	528	548	555	561	562	573	577	567	556	541	504	457	
700	514	557	572	584	599	605	610	613	628	633	625	616	603	572	530	
600	566	602	615	625	635	<u>637</u>	<u>636</u>	<u>647</u>	<u>663</u>	671	668	661	651	623	581	513
500	599	630	642	651	656	<u>651</u>	<u>640</u>	<u>664</u>	<u>680</u>	690	696	692	685	657	612	545
450	609	637	650	659	661	<u>652</u>	<u>634</u>	<u>666</u>	<u>681</u>	693	704	703	696	668	619	554
400	614	640	653	662	662					691	709	710	705	674	622	559
350	615	639	653	663	660					685	709	713	709	677	619	560
300	612	<u>634</u>	<u>649</u>	<u>660</u>						<u>674</u>	<u>706</u>	<u>713</u>	<u>711</u>	675	612	557
250	604	<u>625</u>	<u>641</u>	<u>653</u>						<u>659</u>	<u>700</u>	<u>710</u>	<u>708</u>	669	600	549
200	592	<u>611</u>	<u>629</u>	<u>642</u>						<u>640</u>	<u>690</u>	<u>703</u>	<u>703</u>	659	583	538
100	556	572	594	611							659	680	682	628	534	503
0	503	517	544	566							614	644	648	581	467	453
- 100	433	446	479	507							556	594	602	519	382	387

Table 18 — Hand-reach envelope restrained — Vehicle range ($+ 0,75 \leq G < + 1,25$) — Population mix: 90/10 males/females

Dimensions in millimetres

Elevation above/below R-point	Stations outboard of C/PO							Stations inboard of C/PO								
	400	300	250	200	100	50	0	0	50	100	200	250	300	400	500	600
800	469	518	536	550	570	577	583	582	594	597	587	576	561	525	479	
700	537	579	594	605	620	625	630	632	647	652	644	635	622	592	549	
600	586	622	635	644	655	<u>656</u>	<u>655</u>	<u>665</u>	<u>681</u>	688	686	679	669	641	599	531
500	618	649	661	670	674	<u>669</u>	<u>658</u>	<u>680</u>	<u>696</u>	706	713	709	702	674	628	561
450	627	656	668	677	679	<u>669</u>	<u>651</u>	<u>682</u>	<u>697</u>	708	720	719	713	684	635	570
400	632	658	671	680	679					706	724	725	720	690	637	574
350	632	657	670	680	676					699	724	728	724	691	634	575
300	629	<u>651</u>	<u>666</u>	<u>676</u>						688	<u>721</u>	<u>728</u>	<u>725</u>	689	626	571
250	620	<u>641</u>	<u>657</u>	<u>669</u>						673	<u>714</u>	<u>724</u>	<u>723</u>	683	613	563
200	608	<u>627</u>	<u>645</u>	<u>658</u>						653	<u>703</u>	<u>717</u>	<u>717</u>	672	595	551
100	570	587	609	626							672	693	695	640	545	515
0	515	531	558	580							626	655	660	591	476	464
- 100	443	458	492	520							566	605	612	528	389	397

Table 19 — Hand-reach envelope restrained — Vehicle range ($G \geq + 1,25$) — Population mix: 50/50 males/females

Dimensions in millimetres

Elevation above/below R-point	Stations outboard of C/PO							Stations inboard of C/PO								
	400	300	250	200	100	50	0	0	50	100	200	250	300	400	500	600
800	408	460	479	494	515	522	528	534	547	551	541	529	514	477	430	
700	480	525	540	552	568	574	579	587	603	609	601	591	579	548	505	
600	533	571	585	595	606	<u>608</u>	<u>608</u>	<u>622</u>	<u>639</u>	647	645	638	629	601	558	490
500	568	600	613	622	629	<u>625</u>	<u>615</u>	<u>640</u>	<u>656</u>	667	674	671	664	636	590	523
450	579	608	621	630	635	<u>627</u>	<u>611</u>	<u>643</u>	<u>658</u>	670	683	682	676	647	598	533
400	586	612	625	635	637					668	687	689	684	654	601	538
350	588	612	625	636	636					622	689	693	690	657	599	540
300	586	607	622	633						652	<u>686</u>	<u>694</u>	<u>691</u>	655	592	537
250	580	598	614	627						638	<u>680</u>	<u>691</u>	<u>690</u>	650	580	530
200	569	585	603	617						619	<u>671</u>	<u>685</u>	<u>685</u>	641	564	520
100	535	547	568	587							641	663	665	611	517	486
0	485	493	519	542							598	628	633	566	453	438
- 100	418	423	455	484							541	580	588	506	371	374

Table 20 — Hand-reach envelope restrained — Vehicle range ($G \geq + 1,25$) — Population mix: 75/25 males/females

Dimensions in millimetres

Horizontal reach: forward of the HR reference plane at stations located laterally from the centreplane of operator (C/PO) and at elevations above and below the R-point or actual H-point. The envelope describes a 95 % level of performance of a driver population composed of 75 % male and 25 % female drivers wearing three-point static restraint.

Elevation above/below R-point	Stations outboard of C/PO							Stations inboard of C/PO								
	400	300	250	200	100	50	0	0	50	100	200	250	300	400	500	600
800	449	500	518	533	553	561	566	568	580	584	574	563	548	512	465	
700	518	562	577	588	604	610	615	619	634	640	633	623	611	580	538	
600	569	606	619	629	640	<u>642</u>	<u>641</u>	<u>652</u>	<u>669</u>	677	675	668	658	631	588	520
500	602	633	645	654	661	<u>656</u>	<u>646</u>	<u>669</u>	<u>684</u>	695	702	699	692	664	618	551
450	611	640	653	662	665	<u>657</u>	<u>641</u>	<u>671</u>	<u>685</u>	697	710	709	703	674	625	560
400	617	643	656	666	667					695	714	716	711	680	627	565
350	618	642	655	666	664					689	715	719	716	682	624	566
300	615	<u>636</u>	<u>651</u>	<u>662</u>						<u>678</u>	<u>712</u>	<u>719</u>	<u>717</u>	680	616	562
250	607	<u>627</u>	<u>643</u>	<u>655</u>						<u>662</u>	<u>705</u>	<u>716</u>	<u>715</u>	674	604	555
200	595	<u>613</u>	<u>630</u>	<u>644</u>						<u>643</u>	<u>695</u>	<u>709</u>	<u>709</u>	664	586	543
100	559	573	594	612							664	685	688	633	538	508
0	505	517	543	566							619	649	654	586	471	458
- 100	435	444	477	506							560	600	607	524	386	392

Table 21 — Hand-reach envelope restrained — Vehicle range ($G \geq + 1,25$) — Population mix: 90/10 males/females

Dimensions in millimetres

Elevation above/below R-point	Stations outboard of C/PO							Stations inboard of C/PO								
	400	300	250	200	100	50	0	0	50	100	200	250	300	400	500	600
800	474	524	542	556	576	583	589	588	600	604	594	583	568	532	486	
700	541	584	598	610	625	631	636	638	653	659	651	642	630	599	557	
600	590	627	639	649	660	<u>662</u>	<u>661</u>	<u>670</u>	<u>687</u>	695	693	686	676	649	606	538
500	621	653	665	674	679	<u>675</u>	<u>665</u>	<u>686</u>	<u>701</u>	712	719	716	709	681	635	568
450	630	659	671	681	684	<u>675</u>	<u>658</u>	<u>687</u>	<u>702</u>	714	727	726	720	691	641	576
400	635	662	674	684	684					711	730	732	727	696	643	581
350	636	660	673	683	681					704	731	735	731	698	639	581
300	632	<u>654</u>	<u>668</u>	<u>679</u>						693	<u>727</u>	<u>735</u>	<u>732</u>	695	631	577
250	624	<u>644</u>	<u>660</u>	<u>672</u>						677	<u>720</u>	<u>731</u>	<u>729</u>	689	618	569
200	611	<u>629</u>	<u>647</u>	<u>661</u>						657	<u>709</u>	<u>723</u>	<u>723</u>	678	600	557
100	573	588	610	628							677	699	701	646	550	521
0	517	531	558	580							631	662	667	597	482	470
- 100	445	456	490	519							572	611	619	534	395	403

Table 22 — Hand-reach envelope unrestrained — Vehicle range ($G < - 1,25$) — Population mix: 50/50 males/females

Dimensions in millimetres

Elevation above/below R-point	Stations outboard of C/PO							Stations inboard of C/PO								
	400	300	250	200	100	50	0	0	50	100	200	250	300	400	500	600
800	532	563	573	580	579	570	556	568	575	580	581	575	566	532	477	398
700	605	628	635	638	633	622	606	619	629	637	642	640	633	605	556	482
600	622	679	684	686	677	665	648	659	672	681	691	690	685	662	617	548
500	703	717	720	721	710	698	681	689	703	713	726	727	723	703	661	595
450	717	730	733	733	723	711	695	700	714	725	738	739	737	717	677	612
400	727	739	742	743	733	722	706	708	722	733	747	749	746	727	688	624
350	732	745	748	749	740					739	753	754	752	734	694	631
300	734	746	750	751	744					741	755	756	754	736	697	633
250	730	744	748	750	744					740	753	755	752	734	694	631
200	722	737	742	745							748	749	747	727	688	624
100	692	711	718	724							727	727	724	702	660	595
0	642	667	678	687							692	690	685	660	615	546
- 100	573	605	620	634							642	638	630	601	551	478

Table 23 — Hand-reach envelope unrestrained — Vehicle range ($G < - 1,25$) — Population mix: 75/25 males/females

Dimensions in millimetres

Elevation above/below R-point	Stations outboard of C/PO							Stations inboard of C/PO								
	400	300	250	200	100	50	0	0	50	100	200	250	300	400	500	600
800	573	602	612	617	616	609	598	599	607	613	615	611	602	571	520	447
700	642	665	671	674	668	659	645	645	656	664	671	668	662	637	591	524
600	695	714	718	719	709	698	684	681	694	704	714	713	709	688	646	584
500	732	748	751	750	739	728	713	708	722	732	745	746	743	724	686	626
450	745	760	762	761	750	739	724	718	731	742	755	757	754	736	699	640
400	753	767	770	769	757	746	732	725	739	750	763	764	762	745	708	651
350	757	771	774	773	762					754	767	769	766	749	713	656
300	757	772	774	774	764					755	768	770	767	750	714	657
250	753	768	771	771	762					754	766	767	764	747	711	654
200	744	760	764	765							760	761	758	740	703	646
100	712	732	738	741							739	738	734	713	675	615
0	663	687	695	701							703	701	695	670	628	566
- 100	594	625	637	646							654	649	640	611	564	498

Table 24 — Hand-reach envelope unrestrained — Vehicle range ($G < - 1,25$) — Population mix: 90/10 males/females

Dimensions in millimetres

Horizontal reach: forward of the HR reference plane at stations located laterally from the centreplane of operator (C/PO) and at elevations above and below the R-point or actual H-point. The envelope describes a 95 % level of performance of a driver population composed of 90 % male and 10 % female drivers wearing a type 1 restraint or a restraint system with free shoulder movement.

Elevation above/below R-point	Stations outboard of C/PO							Stations inboard of C/PO								
	400	300	250	200	100	50	0	0	50	100	200	250	300	400	500	600
800	614	639	646	650	647	640	628	629	636	641	643	640	632	605	560	495
700	677	698	703	705	697	688	674	671	681	688	694	693	687	665	624	563
600	725	743	747	747	736	725	710	705	716	725	734	734	730	711	673	616
500	758	774	777	776	763	751	735	729	741	750	761	762	759	742	707	652
450	769	784	786	785	772	760	744	737	749	759	771	772	769	753	719	664
400	776	790	792	791	778	766	749	743	755	765	777	778	776	760	726	672
350	778	793	795	794	781					768	780	781	779	763	729	676
300	777	792	794	793	780					768	780	781	779	763	729	675
250	771	787	789	789	777					765	776	777	775	758	724	670
200	761	778	781	781							770	771	768	750	716	661
100	729	748	753	754							747	747	743	723	686	630
0	680	703	709	713							711	709	703	680	640	581
- 100	612	641	650	656							662	657	649	622	577	514

Table 25 — Hand-reach envelope unrestrained — Vehicle range ($-1,25 \leq G < -0,75$) — Population mix: 50/50 males/females

Dimensions in millimetres

Elevation above/below R-point	Stations outboard of C/PO							Stations inboard of C/PO								
	400	300	250	200	100	50	0	0	50	100	200	250	300	400	500	600
800	545	583	594	601	601	595	586	589	602	611	615	609	596	552	479	374
700	619	651	658	662	654	645	631	633	649	662	672	670	663	629	567	475
600	676	703	708	709	696	683	666	666	684	698	715	716	711	686	634	552
500	717	740	744	742	725	710	690	689	708	723	743	746	744	724	680	607
450	731	753	756	754	735	719	699	697	716	731	752	756	755	737	696	626
400	741	762	765	762	742	726	705	703	721	737	758	762	762	746	707	641
350	747	768	770	767	747					740	761	765	765	751	713	650
300	748	770	772	769	748					741	761	765	765	751	716	654
250	746	768	770	767	747					739	758	762	762	749	714	654
200	740	763	765	763							753	756	756	742	707	649
100	715	741	745	744							735	737	735	719	683	625
0	675	705	711	712							708	707	702	682	644	585
- 100	618	655	664	668							674	668	660	634	591	528

Table 26 — Hand-reach envelope unrestrained — Vehicle range ($- 1,25 \leq G < - 0,75$) — Population mix: 75/25 males/females

Dimensions in millimetres

Horizontal reach: forward of the HR reference plane at stations located laterally from the centreplane of operator (C/PO) and at elevations above and below the R-point or actual H-point. The envelope describes a 95 % level of performance of a driver population composed of 75 % male and 25 % female drivers wearing a type 1 restraint or a restraint system with free shoulder movement.

Elevation above/below R-point	Stations outboard of C/PO							Stations inboard of C/PO								
	400	300	250	200	100	50	0	0	50	100	200	250	300	400	500	600
800	587	621	631	636	636	630	622	620	633	642	646	640	630	591	528	438
700	657	684	691	693	686	677	665	661	676	688	698	696	689	659	605	525
600	710	733	737	737	724	713	698	691	708	722	736	737	733	710	664	593
500	747	767	769	767	751	737	720	711	729	744	762	765	763	744	704	640
450	759	778	780	778	760	746	728	718	736	751	770	774	772	756	718	657
400	768	786	788	785	766	751	733	723	741	756	775	779	779	763	728	669
350	772	791	792	789	770					759	778	782	781	767	733	676
300	773	791	793	790	770					759	777	781	781	767	734	679
250	770	789	790	787	768					756	774	778	778	764	732	678
200	762	782	784	782							769	772	771	757	725	672
100	737	759	763	762							750	751	749	734	700	648
0	696	723	729	729							721	720	716	697	661	607
- 100	640	673	682	685							684	680	673	648	608	551

Table 27 — Hand-reach envelope unrestrained — Vehicle range ($-1,25 \leq G < -0,75$) — Population mix: 90/10 males/females

Dimensions in millimetres

Elevation above/below R-point	Stations outboard of C/PO							Stations inboard of C/PO								
	400	300	250	200	100	50	0	0	50	100	200	250	300	400	500	600
800	628	655	663	667	665	659	649	649	661	668	672	667	657	624	570	493
700	692	714	720	721	713	703	691	687	701	711	720	718	712	685	638	569
600	740	759	762	762	749	737	721	714	730	742	756	756	752	731	690	628
500	773	790	792	790	773	760	742	732	749	763	779	781	779	762	726	668
450	784	800	801	799	781	767	749	738	755	769	786	789	788	772	738	682
400	791	806	808	805	786	771	753	741	759	773	791	794	793	779	745	692
350	794	809	811	808	789					744	792	796	795	782	749	697
300	793	809	811	807	789					773	791	795	794	781	750	698
250	789	806	807	804	785					770	787	791	791	777	746	696
200	781	799	801	798							781	784	784	770	739	689
100	754	775	778	777							761	763	761	746	714	663
0	713	738	743	744							731	731	728	710	676	623
- 100	658	689	696	699							691	689	684	662	623	567

Table 28 — Hand-reach envelope unrestrained — Vehicle range ($-0,75 \leq G < -0,25$) — Population mix: 50/50 males/females

Dimensions in millimetres

Elevation above/below R-point	Stations outboard of C/PO							Stations inboard of C/PO								
	400	300	250	200	100	50	0	0	50	100	200	250	300	400	500	600
800	556	600	613	619	621	617	612	610	626	637	642	635	620	569	485	362
700	632	670	679	682	675	666	656	650	669	684	697	695	687	649	579	474
600	689	723	729	729	714	701	686	679	699	716	735	737	733	706	649	559
500	729	759	763	760	739	723	704	697	718	735	758	763	762	743	696	618
450	742	772	774	771	747	729	709	702	723	741	765	770	771	754	712	639
400	752	780	782	778	752	733	711	706	727	744	768	774	775	761	723	655
350	757	785	787	782	754					745	769	775	777	765	729	665
300	759	787	788	782	753					744	767	773	775	764	731	671
250	757	785	786	780	749					742	763	769	771	761	729	672
200	752	780	781	775							758	763	764	754	723	668
100	731	762	763	756							741	744	744	731	701	649
0	698	732	734	728							721	720	716	700	667	615
- 100	654	692	696	691							697	692	684	661	624	569

Table 29 — Hand-reach envelope unrestrained — Vehicle range ($-0,75 \leq G < -0,25$) — Population mix: 75/25 males/females

Dimensions in millimetres

Elevation above/below R-point	Stations outboard of C/PO							Stations inboard of C/PO								
	400	300	250	200	100	50	0	0	50	100	200	250	300	400	500	600
800	598	637	647	653	654	650	644	641	656	666	670	664	651	607	536	435
700	669	702	709	711	704	696	686	679	696	709	721	719	711	678	618	530
600	723	750	755	754	740	729	715	705	724	739	757	758	754	729	679	603
500	759	783	786	783	764	749	733	721	741	758	778	782	781	762	720	653
450	771	794	796	792	771	756	737	725	746	763	785	789	789	773	734	671
400	779	802	803	799	776	759	740	728	749	766	788	793	793	779	744	684
350	784	806	807	802	778					766	789	794	795	782	749	692
300	785	807	807	802	777					765	787	792	793	782	750	696
250	782	804	805	800	774					762	783	788	789	778	748	696
200	776	799	800	794							777	781	782	772	742	692
100	754	780	781	776							759	762	762	750	721	672
0	721	749	753	749							735	736	734	718	687	638
-100	676	710	715	714							708	705	699	679	644	592

Table 30 — Hand-reach envelope unrestrained — Vehicle range ($-0,75 \leq G < -0,25$) — Population mix: 90/10 males/females

Dimensions in millimetres

Elevation above/below R-point	Stations outboard of C/PO							Stations inboard of C/PO								
	400	300	250	200	100	50	0	0	50	100	200	250	300	400	500	600
800	638	669	678	682	681	677	670	669	682	691	694	689	678	640	579	494
700	704	729	735	736	728	720	709	704	720	732	742	740	733	703	652	577
600	752	774	777	776	763	751	737	728	746	760	775	776	772	750	706	639
500	785	804	806	803	785	771	754	742	761	777	796	799	797	780	742	682
450	795	814	815	811	792	777	758	746	765	781	802	805	805	789	754	697
400	802	820	821	817	796	780	761	747	767	783	804	809	809	795	762	707
350	806	824	824	820	798					783	805	810	810	798	766	714
300	806	824	824	819	797					781	803	808	808	797	767	716
250	802	821	821	817	794					777	798	803	804	793	764	715
200	796	815	816	811							792	796	797	786	758	710
100	773	795	797	793							773	776	777	765	736	689
0	739	765	768	766							747	749	748	734	704	655
- 100	694	725	731	731							716	715	712	694	661	610

Table 31 — Hand-reach envelope unrestrained — Vehicle range ($- 0,25 \leq G < + 0,25$) — Population mix: 50/50 males/females

Dimensions in millimetres

Elevation above/below R-point	Stations outboard of C/PO							Stations inboard of C/PO								
	400	300	250	200	100	50	0	0	50	100	200	250	300	400	500	600
800	564	615	628	635	638	636	635	629	645	656	661	653	638	584	493	362
700	642	687	697	700	693	687	680	670	689	703	717	714	705	665	592	480
600	700	470	747	746	731	720	709	696	717	733	753	755	751	722	663	568
500	738	774	779	775	754	738	722	711	732	749	773	777	777	757	710	629
450	750	786	789	784	759	742	724	716	736	753	777	783	784	768	725	651
400	759	793	795	790	762	743	723	718	738	755	779	785	787	774	735	666
350	764	797	798	792	761					754	778	785	787	776	741	677
300	765	798	798	791	758					752	775	781	784	774	742	683
250	763	795	796	787	752					748	770	776	778	770	740	684
200	759	790	790	781							763	769	771	762	734	681
100	741	773	772	763							747	750	750	741	714	664
0	714	747	747	737							729	729	726	713	684	636
- 100	680	716	715	706							713	708	701	681	648	599

Table 32 — Hand-reach envelope unrestrained — Vehicle range ($-0,25 \leq G < +0,25$) — Population mix: 75/25 males/females

Dimensions in millimetres

Horizontal reach: forward of the HR reference plane at stations located laterally from the centreplane of operator (C/PO) and at elevations above and below the R-point or actual H-point. The envelope describes a 95 % level of performance of a driver population composed of 75 % male and 25 % female drivers wearing a type 1 restraint or a restraint system with free shoulder movement.

Elevation above/below R-point	Stations outboard of C/PO							Stations inboard of C/PO								
	400	300	250	200	100	50	0	0	50	100	200	250	300	400	500	600
800	607	650	662	668	670	668	666	661	675	685	688	681	668	621	545	438
700	680	717	725	728	721	715	708	699	716	729	740	738	729	694	631	538
600	733	766	771	770	757	746	735	723	742	757	774	776	771	745	693	613
500	768	798	800	797	778	764	749	737	757	773	794	797	796	777	734	664
450	780	808	810	805	783	768	752	740	760	777	798	803	803	787	748	682
400	788	814	816	810	786	770	752	741	761	778	800	806	806	793	757	695
350	792	818	818	812	786					777	800	805	806	795	761	704
300	792	818	818	812	784					774	796	802	804	794	763	708
250	790	815	815	808	779					770	791	797	799	789	760	708
200	785	810	810	802							785	790	792	783	755	705
100	766	792	792	785							767	771	772	762	735	688
0	738	767	767	760							747	748	747	734	707	660
- 100	702	735	737	731							725	723	719	702	671	624

Table 33 — Hand-reach envelope unrestrained — Vehicle range ($- 0,25 \leq G < + 0,25$) — Population mix: 90/10 males/females

Dimensions in millimetres

Elevation above/below R-point	Stations outboard of C/PO							Stations inboard of C/PO								
	400	300	250	200	100	50	0	0	50	100	200	250	300	400	500	600
800	645	681	690	695	696	693	690	688	701	709	712	705	693	653	588	498
700	713	743	749	751	744	737	730	723	739	751	760	758	750	719	664	585
600	762	788	792	791	778	767	756	746	764	778	793	794	789	765	719	649
500	794	817	819	816	798	785	770	758	777	793	812	815	813	795	755	693
450	804	826	828	824	803	789	773	760	780	796	816	820	819	804	767	708
400	811	832	833	828	806	791	774	760	780	796	818	822	823	809	775	719
350	814	835	835	830	807					795	817	822	823	811	779	726
300	814	835	835	829	805					791	814	819	821	810	780	728
250	811	832	832	826	801					786	809	814	816	806	777	728
200	806	827	827	821							802	807	809	799	771	724
100	786	809	809	804							783	788	789	779	752	706
0	758	783	785	780							760	763	763	752	724	679
- 100	721	751	754	751							734	735	733	719	689	642

Table 34 — Hand-reach envelope unrestrained — Vehicle range ($+ 0,25 \leq G < + 0,75$) — Population mix: 50/50 males/females

Dimensions in millimetres

Horizontal reach: forward of the HR reference plane at stations located laterally from the centreplane of operator (C/PO) and at elevations above and below the R-point or actual H-point. The envelope describes a 95 % level of performance of a driver population composed of 50 % male and 50 % female drivers wearing a type 1 restraint or a restraint system with free shoulder movement.

Elevation above/below R-point	Stations outboard of C/PO							Stations inboard of C/PO								
	400	300	250	200	100	50	0	0	50	100	200	250	300	400	500	600
800	571	627	641	648	652	653	656	648	661	670	672	664	649	595	505	373
700	651	702	712	715	711	707	705	692	708	720	731	728	719	678	605	493
600	708	753	761	761	748	740	733	720	737	751	767	768	764	735	676	580
500	744	786	790	787	768	756	745	734	751	766	786	790	789	769	721	640
450	756	795	799	795	772	758	745	737	754	768	789	794	794	778	735	660
400	763	801	803	798	772	756	741	738	754	768	790	795	796	783	744	675
350	767	803	805	798	769					766	787	793	795	784	749	685
300	767	802	803	795	764					763	783	789	791	782	750	690
250	765	799	799	790	756					758	776	782	784	776	747	691
200	760	793	792	782						769	774	776	768	741	688	
100	743	775	773	762						752	754	755	747	721	673	
0	721	752	749	737						735	734	732	721	695	648	
- 100	695	726	723	710						722	717	711	694	665	618	

Table 35 — Hand-reach envelope unrestrained — Vehicle range ($+ 0,25 \leq G < + 0,75$) — Population mix: 75/25 males/females

Dimensions in millimetres

Elevation above/below R-point	Stations outboard of C/PO							Stations inboard of C/PO								
	400	300	250	200	100	50	0	0	50	100	200	250	300	400	500	600
800	612	662	674	681	684	684	686	679	691	699	700	692	679	632	556	447
700	687	731	740	743	738	734	731	721	735	746	755	752	743	707	644	548
600	741	779	785	785	773	765	759	747	763	776	790	790	785	759	706	623
500	775	809	813	810	792	781	771	759	776	790	808	811	809	789	746	674
450	786	818	821	817	796	783	772	761	778	793	812	816	815	798	758	691
400	793	823	825	820	797	783	770	761	778	793	812	817	817	803	766	703
350	796	826	826	820	795					790	811	815	816	804	770	711
300	796	825	825	818	791					786	806	811	813	802	771	715
250	793	821	821	813	784					781	800	805	807	798	768	715
200	788	815	814	806							792	798	799	790	763	712
100	771	797	796	787							774	778	779	770	744	697
0	747	774	773	763							754	756	756	745	719	673
- 100	720	748	747	737							736	735	732	718	690	644

Table 36 — Hand-reach envelope unrestrained — Vehicle range ($+ 0,25 \leq G < + 0,75$) — Population mix: 90/10 males/females

Dimensions in millimetres

Horizontal reach: forward of the HR reference plane at stations located laterally from the centreplane of operator (C/PO) and at elevations above and below the R-point or actual H-point. The envelope describes a 95 % level of performance of a driver population composed of 90 % male and 10 % female drivers wearing a type 1 restraint or a restraint system with free shoulder movement.

Elevation above/below R-point	Stations outboard of C/PO							Stations inboard of C/PO								
	400	300	250	200	100	50	0	0	50	100	200	250	300	400	500	600
800	649	691	701	707	709	709	710	705	716	723	723	716	704	663	598	505
700	719	755	763	765	760	756	752	744	758	768	775	772	764	732	676	593
600	768	800	805	805	793	786	779	768	784	796	809	809	804	779	731	658
500	800	828	831	828	812	801	791	779	796	810	827	829	827	807	766	702
450	810	837	839	835	816	804	792	780	798	812	830	833	832	816	778	716
400	816	842	843	838	818	804	791	779	797	812	831	835	835	820	785	726
350	819	844	844	839	816					809	829	834	834	821	788	733
300	819	843	843	837	813					805	825	830	831	819	788	735
250	816	840	839	833	807					798	819	824	825	815	786	735
200	811	834	833	826						811	816	818	818	808	780	731
100	793	816	815	808						792	797	798	798	789	762	716
0	769	793	792	785						770	773	774	774	764	738	692
- 100	739	766	766	759						747	750	749	749	737	709	663

Table 37 — Hand-reach envelope unrestrained — Vehicle range ($+ 0,75 \leq G < + 1,25$) — Population mix: 50/50 males/females

Dimensions in millimetres

Elevation above/below R-point	Stations outboard of C/PO							Stations inboard of C/PO								
	400	300	250	200	100	50	0	0	50	100	200	250	300	400	500	600
800	576	637	651	658	663	666	673	665	673	677	676	667	653	603	520	396
700	658	713	724	728	726	725	729	717	727	734	739	735	726	688	619	512
600	714	764	772	773	764	760	760	748	759	768	779	778	773	745	687	595
500	748	793	798	796	782	775	772	763	774	784	797	800	797	777	730	650
450	758	800	804	801	784	776	771	766	776	786	801	804	803	785	743	668
400	764	804	807	803	783	773	766	766	776	786	800	804	804	789	751	681
350	766	804	806	800	778					782	797	801	802	789	754	689
300	765	801	802	795	770					777	792	796	797	786	754	692
250	761	795	795	787	760					771	784	788	789	780	750	692
200	755	788	786	778							775	779	780	771	743	689
100	739	768	765	754							755	757	758	749	723	674
0	719	745	741	729							736	736	735	724	699	652
- 100	701	724	719	705							722	719	715	701	674	627

Table 38 — Hand-reach envelope unrestrained — Vehicle range ($+ 0,75 \leq G < + 1,25$) — Population mix: 75/25 males/females

Dimensions in millimetres

Elevation above/below R-point	Stations outboard of C/PO							Stations inboard of C/PO								
	400	300	250	200	100	50	0	0	50	100	200	250	300	400	500	600
800	615	671	684	691	696	698	705	696	703	707	705	698	685	641	568	462
700	692	742	753	756	754	753	756	745	754	761	765	761	752	718	656	562
600	746	790	798	798	790	786	786	775	785	794	803	802	796	769	717	634
500	779	818	823	821	807	800	797	788	799	809	821	822	820	799	755	681
450	788	826	829	826	810	801	797	790	801	811	825	827	825	807	766	697
400	794	829	832	828	809	799	793	789	800	810	825	827	826	811	773	707
350	796	830	831	826	804					807	822	825	825	811	776	714
300	796	827	828	821	798					802	816	820	820	808	775	717
250	792	822	821	814	789					795	809	813	813	803	772	716
200	786	815	813	805							800	804	805	795	766	712
100	770	795	793	783							780	783	783	774	747	698
0	749	772	769	758							759	761	760	750	724	677
- 100	727	749	745	733							741	741	739	727	700	653

Table 39 — Hand-reach envelope unrestrained — Vehicle range ($+ 0,75 \leq G < + 1,25$) — Population mix: 90/10 males/females

Dimensions in millimetres

Elevation above/below R-point	Stations outboard of C/PO							Stations inboard of C/PO								
	400	300	250	200	100	50	0	0	50	100	200	250	300	400	500	600
800	650	699	711	717	721	724	730	721	728	732	730	723	711	671	607	515
700	722	766	775	778	776	775	778	767	777	783	787	783	774	742	686	603
600	772	811	818	818	810	806	806	795	806	814	823	821	816	790	741	666
500	804	838	842	840	827	821	817	807	819	829	841	841	838	817	775	708
450	813	846	849	846	830	822	817	808	820	831	844	846	843	825	785	721
400	819	850	852	847	830	820	814	806	819	830	844	846	845	829	792	730
350	821	850	851	846	826					826	841	844	843	829	794	735
300	820	848	848	842	820					820	836	840	839	826	793	737
250	817	843	843	836	812					813	829	833	833	821	790	736
200	811	837	835	828							820	824	825	814	784	731
100	794	818	815	806							799	803	804	794	766	717
0	772	795	791	781							776	780	780	771	744	696
- 100	748	770	766	755							755	758	757	747	720	673

Table 40 — Hand-reach envelope unrestrained — Vehicle range ($+ 1,25 \leq G$) — Population mix: 50/50 males/females

Dimensions in millimetres

Horizontal reach: forward of the HR reference plane at stations located laterally from the centreplane of operator (C/PO) and at elevations above and below the R-point or actual H-point. The envelope describes a 95 % level of performance of a driver population composed of 50 % male and 50 % female drivers wearing a type 1 restraint or a restraint system with free shoulder movement.

Elevation above/below R-point	Stations outboard of C/PO							Stations inboard of C/PO								
	400	300	250	200	100	50	0	0	50	100	200	250	300	400	500	600
800	578	644	658	666	672	677	687	682	681	679	671	663	650	608	538	430
700	663	721	733	738	740	743	753	745	745	745	743	737	728	694	633	537
600	718	770	780	782	780	782	790	783	784	786	787	784	777	750	698	612
500	749	795	802	802	796	796	803	800	802	804	808	807	803	782	736	659
450	757	801	806	805	797	796	803	803	805	807	812	811	808	789	747	674
400	761	801	805	803	793	792	798	802	804	806	811	812	809	793	753	684
350	761	799	801	798	786					802	807	808	807	792	755	689
300	758	793	794	790	777					796	801	802	801	788	753	690
250	753	785	785	780	764					787	792	793	793	781	748	688
200	746	774	774	767							782	783	782	771	741	683
100	728	751	748	740							758	759	758	748	721	667
0	710	728	723	712							734	734	733	723	697	647
- 100	696	709	702	690							715	714	711	700	676	626

Table 41 — Hand-reach envelope unrestrained — Vehicle range ($+ 1,25 \leq G$) — Population mix: 75/25 males/females

Dimensions in millimetres

Elevation above/below R-point	Stations outboard of C/PO							Stations inboard of C/PO								
	400	300	250	200	100	50	0	0	50	100	200	250	300	400	500	600
800	615	678	692	700	706	711	722	712	712	711	704	697	685	646	581	483
700	695	752	764	768	770	773	782	772	773	774	771	766	757	725	668	578
600	749	800	809	811	807	808	816	807	810	812	813	810	803	777	726	645
500	780	825	831	831	823	822	827	823	826	830	833	832	828	806	761	687
450	788	831	836	834	824	822	826	825	829	832	837	836	833	813	771	700
400	793	832	836	833	821	818	821	824	827	831	836	836	834	816	776	708
350	793	830	833	829	814					827	833	833	831	815	778	712
300	791	825	826	821	805					820	826	827	826	811	776	713
250	786	818	818	811	793					811	818	819	818	805	771	711
200	780	808	807	799						808	809	808	796	764	706	
100	762	786	782	772						784	786	785	774	745	691	
0	743	761	755	743						760	761	761	750	723	671	
- 100	726	739	731	717						739	740	739	728	702	652	

Table 42 — Hand-reach envelope unrestrained — Vehicle range ($+ 1,25 \leq G$) — Population mix: 90/10 males/females

Dimensions in millimetres

Elevation above/below R-point	Stations outboard of C/PO							Stations inboard of C/PO								
	400	300	250	200	100	50	0	0	50	100	200	250	300	400	500	600
800	647	705	718	725	731	738	750	736	737	737	731	723	712	676	616	527
700	723	775	786	790	792	795	805	792	795	797	795	789	781	750	696	614
600	774	822	830	831	828	829	836	826	830	833	834	831	825	798	750	674
500	804	847	853	852	844	843	847	840	845	850	854	852	847	825	782	711
450	813	853	858	856	845	843	846	841	847	852	857	856	852	832	790	722
400	818	855	859	855	843	839	841	839	845	850	857	857	853	835	795	730
350	819	854	856	852	837					846	853	854	851	834	796	733
300	817	850	851	845	828					839	847	848	846	830	794	733
250	813	843	843	836	816					830	839	840	839	824	790	730
200	806	835	833	825							829	830	829	816	783	725
100	789	813	809	799							805	807	807	795	765	710
0	768	788	781	769							780	782	782	772	743	691
- 100	748	763	755	740							758	760	760	750	723	672

Annex A

(informative)

Bibliography

- [1] ROE, R. and HAMMOND, D. *SAE Controls Reach Study*, SAE Publication 720199, presented at 1972 SAE Automotive Engineering Congress and Exposition, Detroit, Michigan, U.S.A., January 1972.
- [2] HAMMOND, D., MAURER, D. and RAZGUNAS, L. *Controls Reach — The Hand Reach of Drivers*, SAE Publication 75031, SAE Automotive Congress and Exposition, Detroit, Michigan, U.S.A., February 1975.
- [3] ISO 6549:—²⁾, *Road vehicles — Procedure for H-point determination*.

²⁾ To be published. (Revision of ISO 6549:1980)

ICS 43.040.30

Descriptors: road vehicles, private cars, ergonomics, manual controls, vehicle drivers, hand reach, specifications, layout, position (location).

Price based on 49 pages
