Cutter arbors with tenon drive —

Part 3:

**Dimensions of hollow taper interface with
flange contact surface**

Mandrins porte-fraise à entraînement par tenons —

Partie 3: Dimensions des interfaces à cône creux-face



Reference number
ISO 3937-3:2008(E)

© ISO 2008

PDF disclaimer

This PDF file may contain embedded typefaces. In accordance with Adobe's licensing policy, this file may be printed or viewed but shall not be edited unless the typefaces which are embedded are licensed to and installed on the computer performing the editing. In downloading this file, parties accept therein the responsibility of not infringing Adobe's licensing policy. The ISO Central Secretariat accepts no liability in this area.

Adobe is a trademark of Adobe Systems Incorporated.

Details of the software products used to create this PDF file can be found in the General Info relative to the file; the PDF-creation parameters were optimized for printing. Every care has been taken to ensure that the file is suitable for use by ISO member bodies. In the unlikely event that a problem relating to it is found, please inform the Central Secretariat at the address given below.



COPYRIGHT PROTECTED DOCUMENT

© ISO 2008

All rights reserved. Unless otherwise specified, no part of this publication may be reproduced or utilized in any form or by any means, electronic or mechanical, including photocopying and microfilm, without permission in writing from either ISO at the address below or ISO's member body in the country of the requester.

ISO copyright office
Case postale 56 • CH-1211 Geneva 20
Tel. + 41 22 749 01 11
Fax + 41 22 749 09 47
E-mail copyright@iso.org
Web www.iso.org

Published in Switzerland

Foreword

ISO (the International Organization for Standardization) is a worldwide federation of national standards bodies (ISO member bodies). The work of preparing International Standards is normally carried out through ISO technical committees. Each member body interested in a subject for which a technical committee has been established has the right to be represented on that committee. International organizations, governmental and non-governmental, in liaison with ISO, also take part in the work. ISO collaborates closely with the International Electrotechnical Commission (IEC) on all matters of electrotechnical standardization.

International Standards are drafted in accordance with the rules given in the ISO/IEC Directives, Part 2.

The main task of technical committees is to prepare International Standards. Draft International Standards adopted by the technical committees are circulated to the member bodies for voting. Publication as an International Standard requires approval by at least 75 % of the member bodies casting a vote.

Attention is drawn to the possibility that some of the elements of this document may be the subject of patent rights. ISO shall not be held responsible for identifying any or all such patent rights.

ISO 3937-3 was prepared by Technical Committee ISO/TC 29, *Small tools*, Subcommittee SC 2, *High speed steel cutting tools and their attachments*.

ISO 3937 consists of the following parts, under the general title *Cutter arbors with tenon drive*:

- *Part 1: Dimensions of Morse taper*
- *Part 2: Dimensions of 7/24 taper*
- *Part 3: Dimensions of hollow taper interface with flange contact surface*

Vertical line of dots on the right side of the page.

Cutter arbors with tenon drive —

Part 3: Dimensions of hollow taper interface with flange contact surface

1 Scope

This part of ISO 3937 specifies the dimensions of cutter arbors with tenon drive and with hollow taper interface with flange contact surface (HSK). It also specifies the dimensions of cutter arbors with tenon drive and enlarged contact surface of the cutters.

The interchangeability dimensions of the milling cutter bearing on the cutter arbor are in conformity with ISO 2780. The dimensions of the retaining screw used are specified in ISO 2780.

The hollow taper interface with flange contact surface is in conformance with ISO 12164-1.

2 Normative references

The following referenced documents are indispensable for the application of this document. For dated references, only the edition cited applies. For undated references, the latest edition of the referenced document (including any amendments) applies.

ISO 2768-1, *General tolerances — Part 1: Tolerances for linear and angular dimensions without individual tolerance indications*

ISO 2780, *Milling cutters with tenon drive — Interchangeability dimensions for cutter arbors — Metric series*

ISO 12164-1, *Hollow taper interface with flange contact surface — Part 1: Shanks — Dimensions*

3 Dimensions

3.1 General

All dimensions and tolerances are given in millimetres. Tolerances not specified shall be of tolerance class “m” in accordance with ISO 2768-1.

3.2 Regular contact surface arbors with hollow taper interface with flange contact surface

The dimensions of arbors with regular contact surface arbors with hollow taper interface with flange contact surface are shown in Figure 1 and given in Table 1.

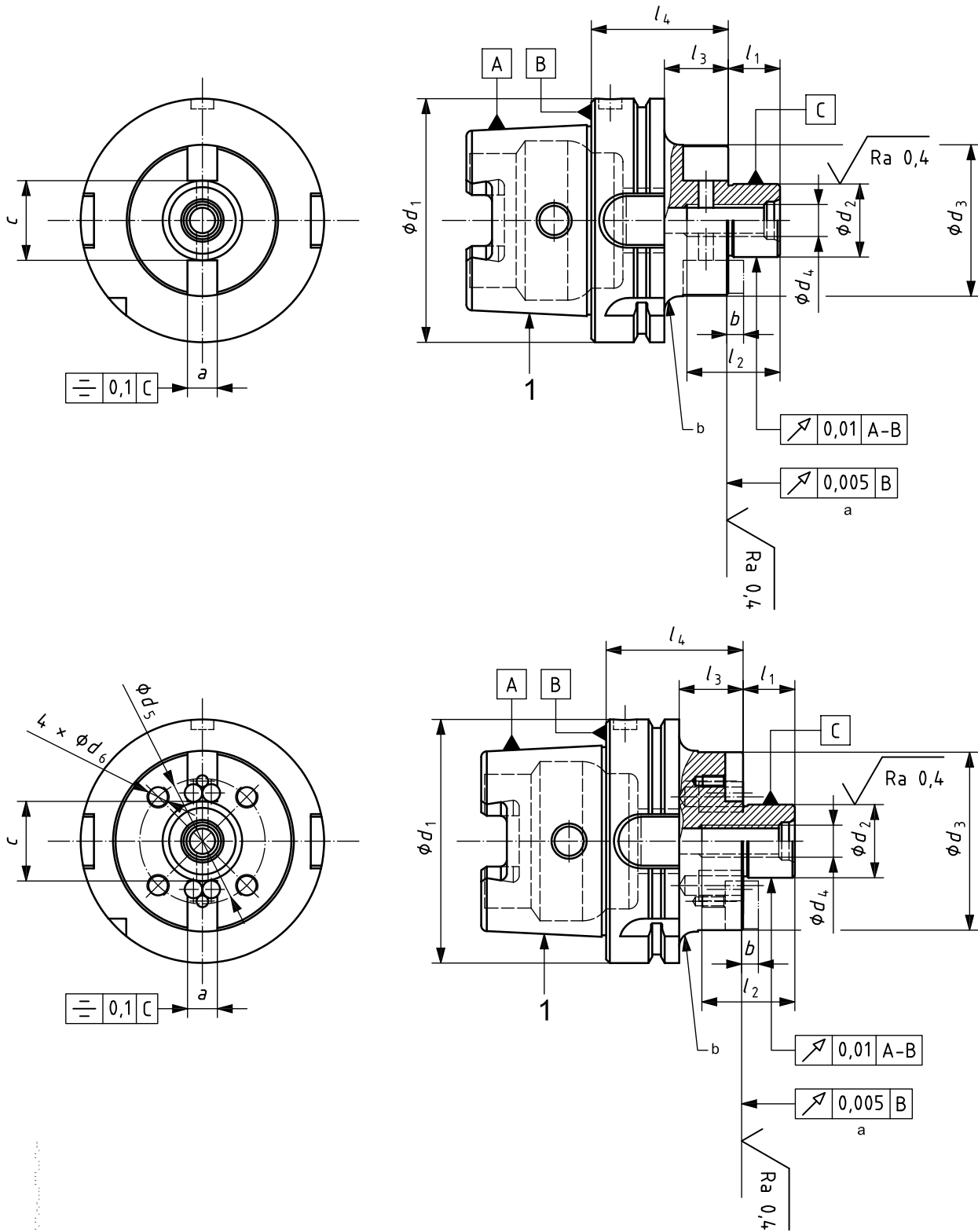

Key

- 1 hollow taper interface with flange contact surface in accordance with ISO 12164-1, Style A
- a Not convex.
- b If required, undercut in accordance with ISO 12164-1.

NOTE This diagram is schematic and is not intended to specify a given design.

Figure 1 — Arbors with hollow taper interface with flange contact surface

Table 1 — Regular contact surface arbors with hollow taper interface with flange contact surface

HSK	d_1	d_2	d_3	d_4	l_1	l_2	l_3^a	l_4	a	b	c
		h6	min.		$\begin{matrix} 0 \\ -1 \end{matrix}$	min.			h11	h11	min.
32	32	13	28	M6	12	18	30	50	8	4,5	14
		16	32	M8	17	20	30	50	8	5	17
40	40	16	32	M8	17	20	30	50	8	5	17
		22	40	M10	19	28	30	50	10	5,6	24,5
50	50	16	32	M8	17	20	14	40	8	5	17
		22	40	M10	19	28	19	45	10	5,6	24,5
		27	48	M12	21	32	34	60	12	6,3	30,5
63	63	16	32	M8	17	20	24	50	8	5	17
		22	40	M10	19	28	24	50	10	5,6	24,5
		27	48	M12	21	32	34	60	12	6,3	30,5
		32	58	M16	24	36	34	60	14	7	33,5
		40	70	M20	27	45	34	60	16	8	44,5
80	80	16	32	M8	17	20	24	50	8	5	17
		22	40	M10	19	28	24	50	10	5,6	24,5
		27	48	M12	21	32	24	50	12	6,3	30,5
		32	58	M16	24	36	34	60	14	7	33,5
		40	70	M20	27	45	34	60	16	8	44,5
100	100	16	32	M8	17	20	21	50	8	5	17
		22	40	M10	19	28	21	50	10	5,6	24,5
		27	48	M12	21	32	21	50	12	6,3	30,5
		32	58	M16	24	36	21	50	14	7	33,5
		40	70	M20	27	45	31	60	16	8	44,5
		50	90	M24	30	50	41	70	18	9	55
		60	110	M30	40	63	46	75	20	10	65

^a Values given only for information.

3.3 Enlarged contact surface arbors with hollow taper interface with flange contact surface

The dimensions of enlarged contact surface arbors with hollow taper interface with flange contact surface are shown in Figure 1 and given in Table 2:

Table 2 — Enlarged contact surface arbors with hollow taper interface with flange contact surface

HSK	d_1	d_2	d_3	d_4	d_5	d_6	l_1	l_2	l_3^a	l_4	a	b	c
		h6	min.				$\begin{matrix} 0 \\ -1 \end{matrix}$	min.			h11	h11	min.
40	40	16	38	M8	—	—	17	20	30	50	8	5	17
		22	48	M10	—	—	19	28	30	50	10	5,6	24,5
		27	60	M12	—	—	21	32	34	60	12	6,3	30,5
50	50	16	38	M8	—	—	17	20	14	40	8	5	17
		22	48	M10	—	—	19	28	19	45	10	5,6	24,5
		27	60	M12	—	—	21	32	34	60	12	6,3	30,5
		32	78	M16	—	—	24	36	34	60	14	7	33,5
63	63	16	38	M8	—	—	17	20	24	50	8	5	17
		22	48	M10	—	—	19	28	24	50	10	5,6	24,5
		27	60	M12	—	—	21	32	34	60	12	6,3	30,5
		32	78	M16	—	—	24	36	34	60	14	7	33,5
		40	89	M20	66,7	M12	27	45	34	60	16	8	44,5
80	80	16	38	M8	—	—	17	20	14	40	8	5	17
		22	48	M10	—	—	19	28	24	50	10	5,6	24,5
		27	60	M12	—	—	21	32	24	50	12	6,3	30,5
		32	78	M16	—	—	24	36	34	60	14	7	33,5
		40	89	M20	66,7	M12	27	45	34	60	16	8	44,5
100	100	16	38	M8	—	—	17	20	14	40	8	5	17
		22	48	M10	—	—	19	28	21	50	10	5,6	24,5
		27	60	M12	—	—	21	32	21	50	12	6,3	30,5
		32	78	M16	—	—	24	36	21	50	14	7	33,5
		40	89	M20	66,7	M12	27	45	31	60	16	8	44,5
		50	120	M24	—	—	30	50	41	70	18	9	55
		60	130	M30	101,6	M16	40	63	46	75	20	10	65

^a Values given only for information.

4 Material

The material is left to the manufacturer's discretion, but the tensile strength shall be at least 800 N/mm².

Hardness shall be 56 (+4) HRC.

Bibliography

- [1] ISO 8015, *Technical drawings — Fundamental tolerancing principle*

ICS 25.060.20

Price based on 5 pages