**Metallic powders, excluding powders for
hardmetals — Determination of
compressibility in uniaxial compression**

*Poudres métalliques, à l'exclusion des poudres pour métaux-durs —
Détermination de la compressibilité sous compression uniaxiale*



Reference number
ISO 3927:2011(E)

© ISO 2011

PDF disclaimer

This PDF file may contain embedded typefaces. In accordance with Adobe's licensing policy, this file may be printed or viewed but shall not be edited unless the typefaces which are embedded are licensed to and installed on the computer performing the editing. In downloading this file, parties accept therein the responsibility of not infringing Adobe's licensing policy. The ISO Central Secretariat accepts no liability in this area.

Adobe is a trademark of Adobe Systems Incorporated.

Details of the software products used to create this PDF file can be found in the General Info relative to the file; the PDF-creation parameters were optimized for printing. Every care has been taken to ensure that the file is suitable for use by ISO member bodies. In the unlikely event that a problem relating to it is found, please inform the Central Secretariat at the address given below.



COPYRIGHT PROTECTED DOCUMENT

© ISO 2011

All rights reserved. Unless otherwise specified, no part of this publication may be reproduced or utilized in any form or by any means, electronic or mechanical, including photocopying and microfilm, without permission in writing from either ISO at the address below or ISO's member body in the country of the requester.

ISO copyright office
Case postale 56 • CH-1211 Geneva 20
Tel. + 41 22 749 01 11
Fax + 41 22 749 09 47
E-mail copyright@iso.org
Web www.iso.org

Published in Switzerland

Foreword

ISO (the International Organization for Standardization) is a worldwide federation of national standards bodies (ISO member bodies). The work of preparing International Standards is normally carried out through ISO technical committees. Each member body interested in a subject for which a technical committee has been established has the right to be represented on that committee. International organizations, governmental and non-governmental, in liaison with ISO, also take part in the work. ISO collaborates closely with the International Electrotechnical Commission (IEC) on all matters of electrotechnical standardization.

International Standards are drafted in accordance with the rules given in the ISO/IEC Directives, Part 2.

The main task of technical committees is to prepare International Standards. Draft International Standards adopted by the technical committees are circulated to the member bodies for voting. Publication as an International Standard requires approval by at least 75 % of the member bodies casting a vote.

Attention is drawn to the possibility that some of the elements of this document may be the subject of patent rights. ISO shall not be held responsible for identifying any or all such patent rights.

ISO 3927 was prepared by Technical Committee ISO/TC 119, *Powder metallurgy*, Subcommittee SC 2, *Sampling and testing methods for powders (including powders for hardmetals)*.

This fourth edition cancels and replaces the third edition (ISO 3927:2001), of which it constitutes a minor revision. It incorporates ISO 3927:2001/Cor.1:2008, with the following changes.

- **Clause 8, Title:** Footnote 1 has been deleted.
- **Subclause 8.1:** The original text was replaced with a new paragraph.
- **Subclauses 8.1 and 8.2** have been renumbered as 8.2 and 8.3.

Metallic powders, excluding powders for hardmetals — Determination of compressibility in uniaxial compression

1 Scope

This International Standard specifies methods for measuring the extent to which a metallic powder is compacted when subjected to uniaxial compressive loading in a confining die under specified conditions.

The method is not applicable to powders for hardmetals.

2 Symbols

For the purposes of this document, the symbols given in Table 1 apply.

Table 1 — Symbols

Symbol	Designation	Unit
ρ_p	Compressibility ^a	g/cm ³
m	Mass of the compact	g
V	Volume of the compact	cm ³

^a If the compressibility is measured at one pressure only, e.g. 400 N/mm², the symbol becomes $\rho_{p(400)}$.

3 Principle

Uniaxial compaction of a powder in a confining die by double-action pressing. Samples of the powder may be pressed either at a single specified pressure or at a series of specified pressures. After ejection from the die, the density of the compacts is determined.

The density obtained in the former case represents the compressibility of the powder at the specified pressure. The densities obtained in the latter case can be utilized for drawing the compressibility curve of the powder, i.e. a plot of the density as a function of the compacting pressure.

4 Apparatus

4.1 Die, preferably of cemented carbide, or alternatively of tool steel, and two punches for producing either cylindrical or rectangular compacts.

The cylindrical die should be capable of making compacts of diameter 20 mm to 26 mm with a height to diameter ratio between 0,8 and 1. An example of a design for tooling is shown in Figure 1.

The rectangular die should be capable of making compacts of 30 mm × 12 mm and of thickness 5 mm to 7 mm. An example of a design for tooling is shown in Figure 2.

Mating parts shall be fitted and lapped.

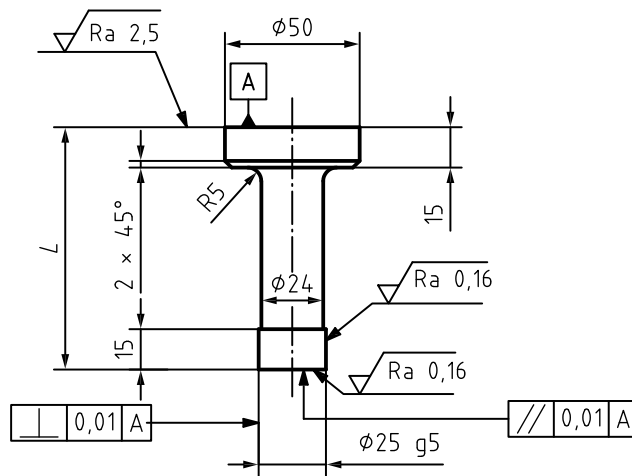

a) Upper punch, $L = H - 10$

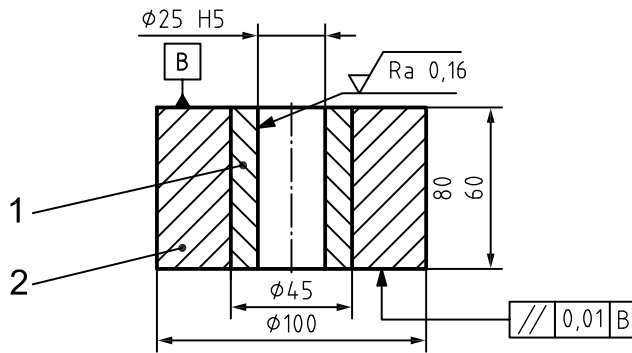

b) Die, $H = 60 \text{ mm to } 80 \text{ mm}$

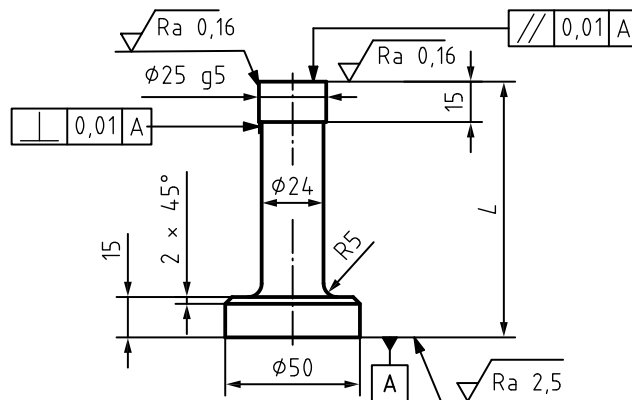

c) Lower punch, $L = H + 35$

Key

- 1 cemented carbide
- 2 shrink ring
- H height of tool die

Figure 1 — Example of tooling to produce a cylindrical test piece

Dimensions in millimetres

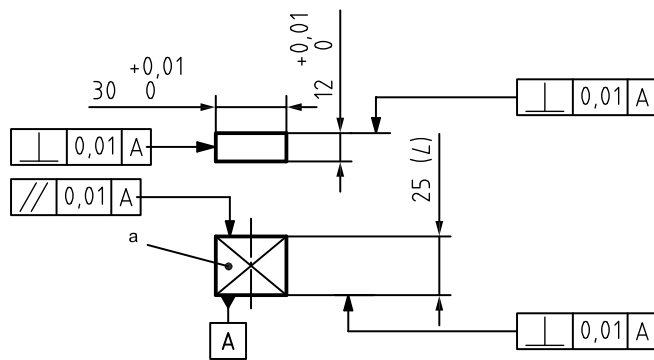

a) Upper punch, $L = 25$

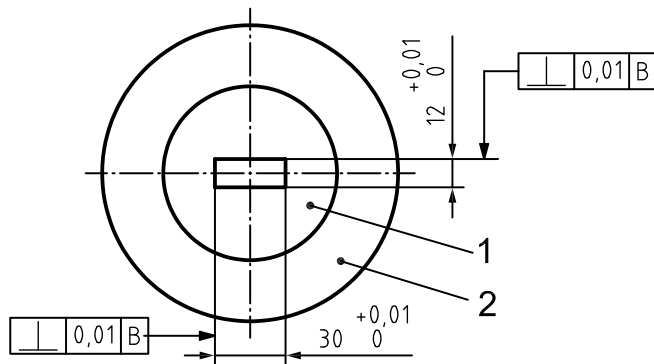

b) Die

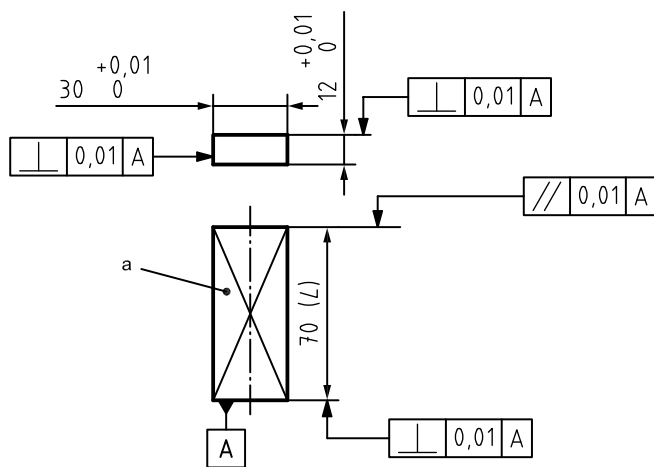

c) Lower punch, $L = 70$

Key

- 1 cemented carbide
- 2 shrink ring
- a Steel, HRC 60 to 62.

Figure 2 — Example of tooling to produce a rectangular test piece

4.2 Press, capable of applying forces up to approximately 500 kN with a minimum accuracy of $\pm 1\%$ and adjustable to permit an even increase of the force at a rate not higher than 50 kN/s.

4.3 Balance, capable of weighing at least 100 g to an accuracy of $\pm 0,01$ g.

4.4 Micrometer or other suitable measuring device for measuring the dimensions of the compacts to an accuracy of $\pm 0,01$ mm.

5 Sampling

The quantity of the test sample shall be chosen to give the required number of test pieces (see Clause 7) with the dimensions specified in 4.1. If necessary, preliminary tests should be made in order to establish the quantity of powder needed for fulfilling this requirement.

6 Procedure

6.1 Cleaning of the die and punches

Wipe the die cavity and the punches with soft and clean paper towelling soaked with an appropriate solvent such as acetone. Allow the solvent to evaporate.

6.2 Powder testing conditions

WARNING — Seizure and excessive die wear may occur, particularly at high compacting pressures.

6.2.1 Powders which do not contain a lubricant can be tested

- a) in a dry die,
- b) in a die with lubricated walls (see 6.3.2), and
- c) after admixing a lubricant (see 6.3.3) and in a dry die.

6.2.2 Powders which contain a lubricant can be tested

- a) in a dry die, and
- b) after admixing additional lubricant (see 6.3.3) and in a dry die.

6.3 Lubrication

6.3.1 General

Use one of the two following methods of lubrication.

6.3.2 Die wall lubrication

Apply to the die walls a mixture or a solution of a lubricant in a volatile organic liquid, e.g. 100 g of zinc stearate in 1 000 cm³ of acetone. After any excess liquid has drained away, allow the solution adhering to the walls to evaporate, leaving a thin layer of lubricant.

6.3.3 Lubrication of powder

Lubricate the powder to be tested by thoroughly mixing into it a quantity (e.g. 0,5 % to 1,5 %) of a suitable solid lubricant (e.g. zinc stearate or synthetic wax).

6.4 Compacting and ejection

Insert the lower punch into the die cavity. Position the die to the desired filling height by using supporting spacers between the die and the foot of the lower punch. Pour the sample into the die cavity, taking the usual precautions to ensure that the powder is uniformly distributed in the die cavity. Position the upper punch and place the die with the punches between the platens of the press. Apply and release a preliminary force of approximately 20 kN. Remove the spacers supporting the die. If the die is supported by springs, or in a similar way, it is not necessary to apply the preliminary force.

Apply the final force at a constant rate that shall not exceed 50 kN/s. Release the force as soon as the predetermined pressure is reached.

Eject the compact from the die by means of the lower punch.

The procedure of compacting and ejection is exemplified in Figure 3.

After ejection and, if necessary, deburring, weigh the compact to the nearest 0,01 g. Measure its dimensions to the nearest 0,01 mm.

6.5 Compacting pressures

For determining the compressibility curve of a powder at a series of pressures, it is recommended that the applied pressures 200 N/mm², 400 N/mm², 500 N/mm², 600 N/mm² and 800 N/mm² be used. If compressibility is to be determined at a single pressure only, it should preferably be measured at one of these pressures or by agreement between the parties concerned.

.....

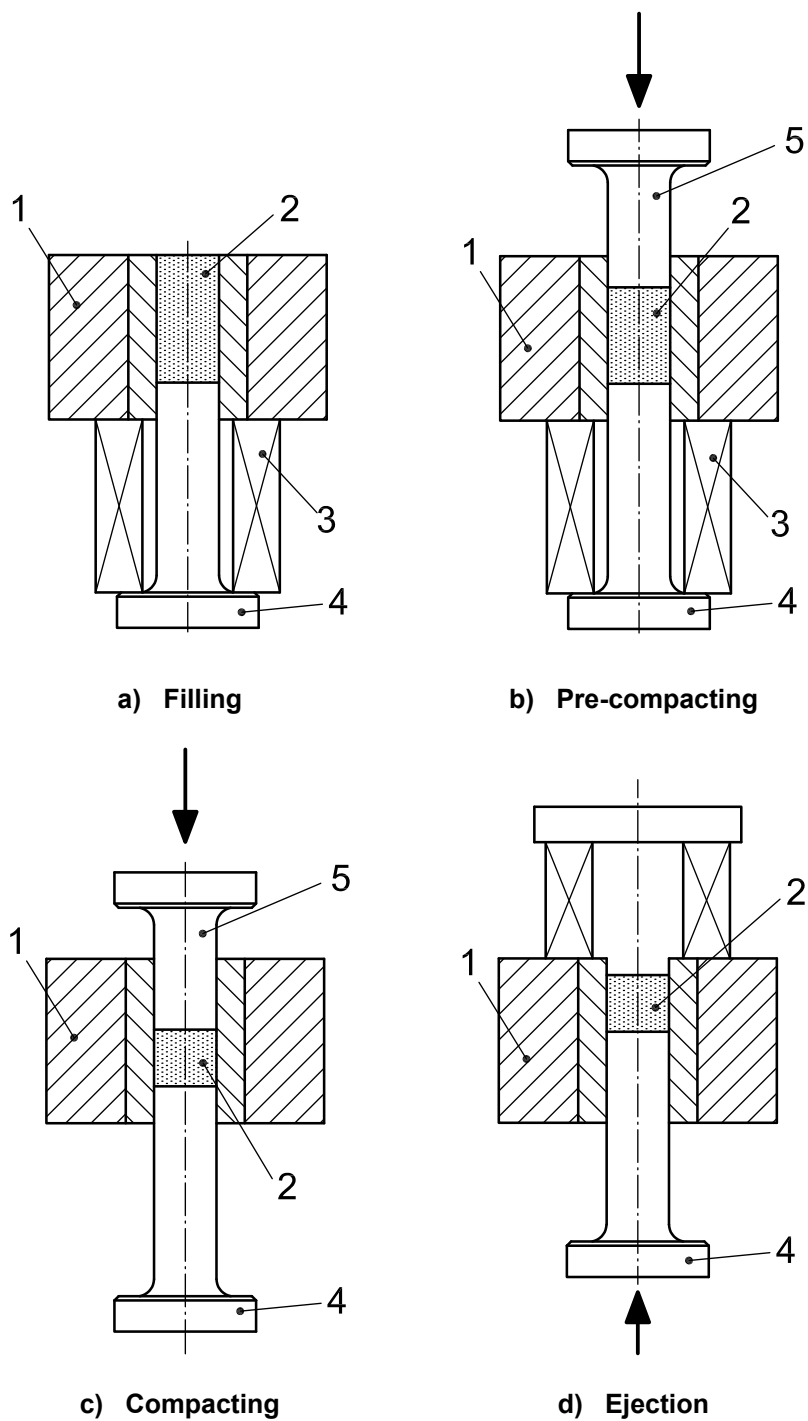

Key

- 1 die
- 2 sample powder
- 3 spacer

- 4 lower punch
- 5 upper punch

Figure 3 — Procedure of compacting and ejection

7 Expression of results

7.1 The density of the compact is given by the formula:

$$\rho_p = \frac{m}{V}$$

Report the density to the nearest 0,01 g/cm³.

7.2 Report the compressibility as the average of three density determinations, calculated to the nearest 0,01 g/cm³, obtained at the specified compacting pressure.

7.3 The compressibility curve of a powder is drawn through points representing single determinations of ρ_p at the specified compacting pressures.

8 Precision

8.1 The precision data specified in 8.2 and 8.3 are quoted from ASTM B331-95. The specimens that were the subject of ASTM B331-95 had a diameter of 25,4 mm and heights varying between 6,9 mm and 7,4 mm. Despite the difference in specimen dimensions, it is considered that these precision data provide an indication of the precision to be expected with the specimens specified in this International Standard.

8.2 For the density determination method, the repeatability interval, r , for ferrous and nonferrous powders is 0,025 g/cm³. On the basis of the test error alone, the difference in absolute value of individual test results obtained in the same laboratory on the same material will be expected to exceed 0,025 g/cm³ only about 5 % of the time.

8.3 For the density determination method, the reproducibility interval, R , for ferrous and nonferrous powders is 0,07 g/cm³. On the basis of the test error alone, the difference in absolute value between individual test results obtained in two different laboratories on the same material will be expected to exceed R only about 5 % of the time. Thus, if a larger difference is found, there is reason to question one or both test results.

9 Test report

The test report shall include the following information:

- a) a reference to this International Standard, i.e. ISO 3927:2010;
- b) all details necessary for the identification of the test sample;
- c) the type of test piece;
- d) the type, nature and amount of the lubricant, if it has been added to the powder (in certain cases it may be desirable to report how the lubricant was added);
- e) the compacting pressures;
- f) the result obtained;
- g) all operations not specified in this International Standard or regarded as optional;
- h) details of any occurrence which may have affected the result.

Bibliography

- [1] ASTM B331-95, *Standard Test Method for Compressibility of Metal Powders in Uniaxial Compaction*

Vertical text on the right side of the page.

ICS 77.160

Price based on 8 pages