

INTERNATIONAL STANDARD



3912

3912-77

4851903 0029109 4

J-17-01

INTERNATIONAL ORGANIZATION FOR STANDARDIZATION • МЕЖДУНАРОДНАЯ ОРГАНИЗАЦИЯ ПО СТАНДАРТИЗАЦИИ • ORGANISATION INTERNATIONALE DE NORMALISATION

Woodruff keys and keyways

Clavetage par clavettes disques

First edition -- 1977-06-15

UDC 621.886.6

Ref. No. ISO 3912-1977 (E)

Descriptors : keys and keyways, Woodruff keys, dimensions, dimensional tolerances, designation.

Price based on 4 pages

320210

FOREWORD

ISO (the International Organization for Standardization) is a worldwide federation of national standards institutes (ISO member bodies). The work of developing International Standards is carried out through ISO technical committees. Every member body interested in a subject for which a technical committee has been set up has the right to be represented on that committee. International organizations, governmental and non-governmental, in liaison with ISO, also take part in the work.

Draft International Standards adopted by the technical committees are circulated to the member bodies for approval before their acceptance as International Standards by the ISO Council.

International Standard ISO 3912 was developed by Technical Committee ISO/TC 14, *Shafts for machinery and accessories*, and was circulated to the member bodies in October 1975.

It has been approved by the member bodies of the following countries :

Belgium	Mexico	Turkey
Brazil	Netherlands	United Kingdom
Finland	Romania	U.S.S.R.
France	South Africa, Rep. of	Yugoslavia
India	Spain	
Italy	Switzerland	

The member bodies of the following countries expressed disapproval of the document on technical grounds :

Czechoslovakia
Germany
Sweden

Woodruff keys and keyways

1 SCOPE

This International Standard specifies the dimensional characteristics of Woodruff keys and of the alternative Whitney key and of the corresponding keyways in shaft and hub. It also gives the relationship to be observed between the diameter of the shaft and the section of the key for both torque transmission and positional applications.

2 FIELD OF APPLICATION

This International Standard is intended for general application to cylindrical shafts and cylindrical shaft ends.¹⁾

3 DIMENSIONS AND TOLERANCES OF KEYS

See the figures and table 1 on page 2.

4 MATERIAL

Steel having a tensile strength of not less than 590 N/mm² in the finished condition, unless otherwise agreed between the interested parties.

NOTE — The mechanical properties of the steel will be specified completely at a later date.

5 SHAPE, DIMENSIONS AND TOLERANCES OF KEYWAYS

See the figure and table 2 on page 3.

6 RELATIONSHIP OF SHAFT DIAMETER TO KEY SIZE

Two series of relationships between shaft diameter and key size are given in table 3, page 4: series 1 for torque applications and series 2 for positional applications (for example where, as in the case of an interference fit, the torque is not transmitted through the key but through the shaft/hub interface).

7 DESIGNATION

A woodruff key shall be designated by its width and its height and by reference to this International Standard.

Examples

— For a key of normal form and with a section $b \times h_1 = 5 \times 6,5$ mm :

Key ISO 3912 — 5 × 6,5

— For a key of Whitney form and with a section $b \times h_2 = 5 \times 5,2$ mm :

Key ISO 3912 — 5 × 5,2

1) The relationship between the diameter of a conical shaft end and the key section is given in ISO . . . (in preparation).

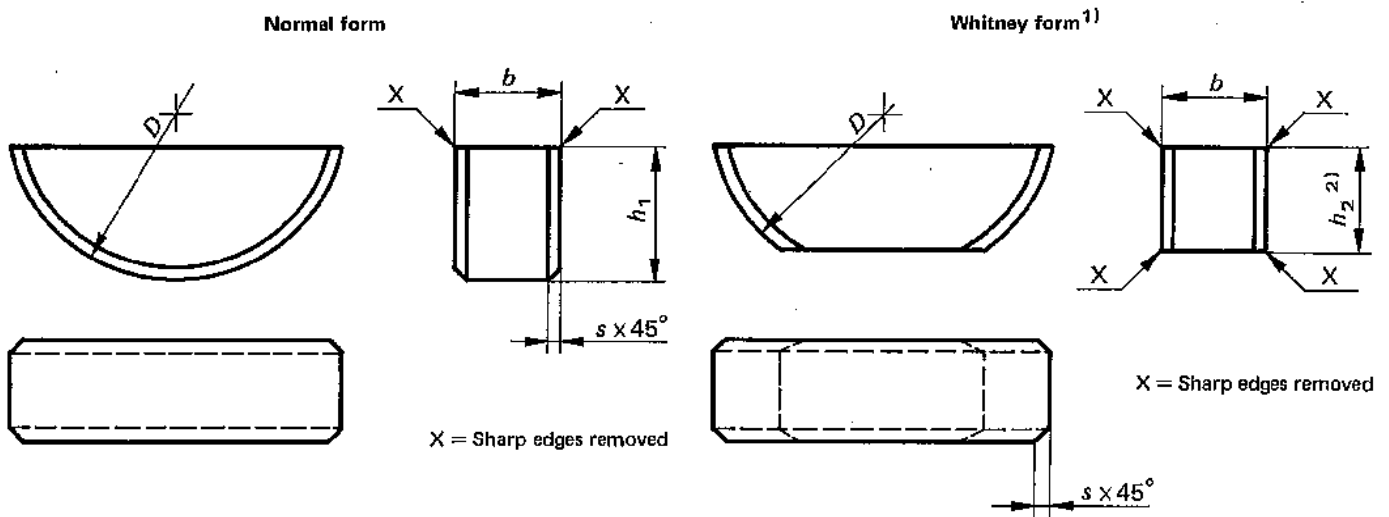

TABLE 1 - Dimensions and tolerances of keys

Values in millimetres

Width <i>b</i>		Height <i>h</i> ₁		Diameter <i>D</i>		Chamfer <i>s</i>	
nominal	tolerance h9 ³⁾	nominal	tolerance h11	nominal	tolerance h12	min.	max.
1,0	0 -0,025	1,4	0 -0,060	4	0 -0,120	0,16	0,25
1,5		2,6		7			
2,0		2,6		7			
2,0		3,7	0 -0,075	10	0 -0,150	0,16	0,25
2,5		3,7		10			
3,0		5,0		13	0 -0,180	0,16	0,25
3,0		6,5		16			
4,0	0 -0,030	6,5	0 -0,090	16	0 -0,210	0,25	0,40
4,0		7,5		19			
5,0		6,5		16			
5,0		7,5		0 -0,210	19	0,25	0,40
5,0		9,0			22		
6,0		9,0			22		
6,0		10,0			25		
8,0	0 -0,036	11,0	0 -0,110	28	0 -0,250	0,40	0,60
10,0		13,0		32			

1) This form should only be adopted by agreement between the interested parties.

2) In this case the height *h*₂ of the key shall be equal to 0,8 times the height of the Woodruff key of normal form, i.e. *h*₂ = 0,8 *h*₁. The calculated value shall be rounded off to the nearest 0,1 mm.

3) A closer tolerance may be adopted subject to agreement between the interested parties.

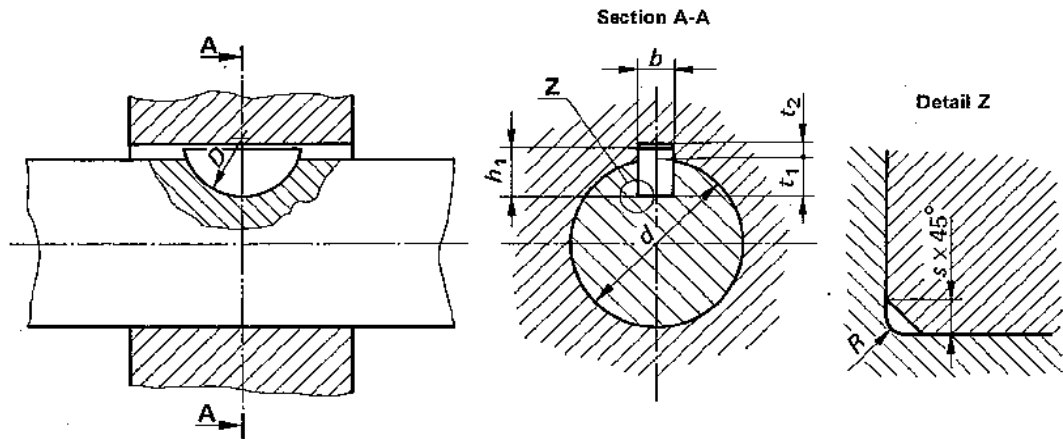

TABLE 2 - Dimensions and tolerances of keyways

Values in millimetres

Key size of normal form $b \times h_1 \times D$ or equivalent Whitney form	Width b			Depth				Radius R		
	nomi- nal	Tolerance			Shaft t_1		Hub t_2		max.	min.
		Normal fit		Close fit	nomi- nal	toler- ance	nomi- nal	toler- ance		
		Shaft N9	Hub J _s 9	Shaft and hub P9						
1,0 x 1,4 x 4	1,0				1,0		0,6		0,16	0,08
1,5 x 2,6 x 7	1,5				2,0		0,8		0,16	0,08
2,0 x 2,6 x 7	2,0				1,8	+0,1 0	1,0		0,16	0,08
2,0 x 3,7 x 10	2,0	-0,004 -0,029	+0,012 -0,012	-0,006 -0,031	2,9		1,0		0,16	0,08
2,5 x 3,7 x 10	2,5				2,7		1,2		0,16	0,08
3,0 x 5,0 x 13	3,0				3,8		1,4		0,16	0,08
3,0 x 6,5 x 16	3,0				5,3		1,4	+0,1 0	0,16	0,08
4,0 x 6,5 x 16	4,0				5,0	+0,2 0	1,8		0,25	0,16
4,0 x 7,5 x 19	4,0				6,0		1,8		0,25	0,16
5,0 x 6,5 x 16	5,0				4,5		2,3		0,25	0,16
5,0 x 7,5 x 19	5,0	0 -0,030	+0,015 -0,015	-0,012 -0,042	5,5		2,3		0,25	0,16
5,0 x 9,0 x 22	5,0				7,0		2,3		0,25	0,16
6,0 x 9,0 x 22	6,0				6,5		2,8		0,25	0,16
6,0 x 10,0 x 25	6,0				7,5	+0,3 0	2,8		0,25	0,16
8,0 x 11,0 x 28	8,0	0 -0,036	+0,018 -0,018	-0,015 -0,051	8,0		3,3	+0,2 0	0,40	0,25
10,0 x 13,0 x 32,0	10,0				10,0		3,3		0,40	0,25

TABLE 3 — Relationship : shaft diameter — key size

Dimensions in millimetres

Shaft diameter <i>d</i>				Key size of normal form $b \times h_1 \times D$ or equivalent Whitney form
Series 1		Series 2		
Over	Including	Over	Including	
3	4	3	4	1,0 x 1,4 x 4
4	5	4	6	1,5 x 2,6 x 7
5	6	6	8	2,0 x 2,6 x 7
6	7	8	10	2,0 x 3,7 x 10
7	8	10	12	2,5 x 3,7 x 10
8	10	12	15	3,0 x 5,0 x 13
10	12	15	18	3,0 x 6,5 x 16
12	14	18	20	4,0 x 6,5 x 16
14	16	20	22	4,0 x 7,5 x 19
16	18	22	25	5,0 x 6,5 x 16
18	20	25	28	5,0 x 7,5 x 19
20	22	28	32	5,0 x 9,0 x 22
22	25	32	36	6,0 x 9,0 x 22
25	28	36	40	6,0 x 10,0 x 25
28	32	40	—	8,0 x 11,0 x 28
32	38	—	—	10,0 x 13,0 x 32