**Hydrometry — Open channel flow
measurement using rectangular
broad-crested weirs**

*Hydrométrie — Mesure de débit des liquides dans les canaux
découverts au moyen de déversoirs rectangulaires à seuil épais*



Reference number
ISO 3846:2008(E)

© ISO 2008

PDF disclaimer

This PDF file may contain embedded typefaces. In accordance with Adobe's licensing policy, this file may be printed or viewed but shall not be edited unless the typefaces which are embedded are licensed to and installed on the computer performing the editing. In downloading this file, parties accept therein the responsibility of not infringing Adobe's licensing policy. The ISO Central Secretariat accepts no liability in this area.

Adobe is a trademark of Adobe Systems Incorporated.

Details of the software products used to create this PDF file can be found in the General Info relative to the file; the PDF-creation parameters were optimized for printing. Every care has been taken to ensure that the file is suitable for use by ISO member bodies. In the unlikely event that a problem relating to it is found, please inform the Central Secretariat at the address given below.



COPYRIGHT PROTECTED DOCUMENT

© ISO 2008

All rights reserved. Unless otherwise specified, no part of this publication may be reproduced or utilized in any form or by any means, electronic or mechanical, including photocopying and microfilm, without permission in writing from either ISO at the address below or ISO's member body in the country of the requester.

ISO copyright office
Case postale 56 • CH-1211 Geneva 20
Tel. + 41 22 749 01 11
Fax + 41 22 749 09 47
E-mail copyright@iso.org
Web www.iso.org

Published in Switzerland

Contents

Page

Foreword.....	iv
1 Scope	1
2 Normative references	1
3 Terms and definitions.....	1
4 Symbols	1
5 Installation	2
5.1 General.....	2
5.2 Selection of site	2
5.3 Installation conditions	3
6 General maintenance requirements.....	4
7 Measurement of head(s)	5
7.1 General.....	5
7.2 Stilling or float well	5
7.3 Zero setting	5
8 Rectangular broad-crested weirs.....	6
8.1 Specification for the standard weir.....	6
8.2 Location of the head gauge section	7
8.3 Provision for modular flow	7
9 Discharge relationships	7
9.1 Modular flow discharge equation.....	7
9.2 Modular coefficient of discharge	7
9.3 Limitations for operation in the modular flow range	10
9.4 Drowned flow discharge equation	10
9.5 Limitations for operation in the drowned flow range.....	10
10 Uncertainties in flow measurement	11
10.1 General.....	11
10.2 Statement of the uncertainty of a flow measurement in a channel	11
10.3 Combining measurement uncertainties	12
10.4 Uncertainty of discharge coefficient $u(C)$ for the broad-crested weir	13
10.5 Uncertainty budget	13
11 Example	13
11.1 General.....	13
11.2 Characteristics — Gauging structure	14
11.3 Characteristics — Gauged head instrumentation	14
11.4 The discharge coefficient	14
11.5 The discharge estimate	14
11.6 Uncertainty statement	15
Annex A (informative) Modular limit.....	17
Annex B (informative) Gauged head discharge coefficient and total head discharge coefficient	18
Annex C (informative) Introduction to measurement uncertainty.....	19
Annex D (informative) Sample measurement performance for use in hydrometric worked examples.....	26
Bibliography	28

Foreword

ISO (the International Organization for Standardization) is a worldwide federation of national standards bodies (ISO member bodies). The work of preparing International Standards is normally carried out through ISO technical committees. Each member body interested in a subject for which a technical committee has been established has the right to be represented on that committee. International organizations, governmental and non-governmental, in liaison with ISO, also take part in the work. ISO collaborates closely with the International Electrotechnical Commission (IEC) on all matters of electrotechnical standardization.

International Standards are drafted in accordance with the rules given in the ISO/IEC Directives, Part 2.

The main task of technical committees is to prepare International Standards. Draft International Standards adopted by the technical committees are circulated to the member bodies for voting. Publication as an International Standard requires approval by at least 75 % of the member bodies casting a vote.

Attention is drawn to the possibility that some of the elements of this document may be the subject of patent rights. ISO shall not be held responsible for identifying any or all such patent rights.

ISO 3846 was prepared by Technical Committee ISO/TC 113, *Hydrometry*, Subcommittee SC 2, *Flow measurement structures*.

This third edition cancels and replaces the second edition (ISO 3846:1989), of which it constitutes a technical revision.

Hydrometry — Open channel flow measurement using rectangular broad-crested weirs

1 Scope

This International Standard lays down requirements for the use of rectangular broad-crested weirs for the accurate measurement of flow of clear water in open channels under free flow conditions.

2 Normative references

The following referenced documents are indispensable for the application of this document. For dated references, only the edition cited applies. For undated references, the latest edition of the referenced document (including any amendments) applies.

ISO 772, *Hydrometry — Vocabulary and symbols*

3 Terms and definitions

For the purposes of this document, the terms and definitions given in ISO 772 apply.

4 Symbols

A	m^2	area of approach channel
b	m	width of weir crest perpendicular to flow direction
C	—	discharge coefficient (gauged head)
f	—	drowned flow reduction factor
fC	—	combined coefficient of discharge
C_d	—	discharge coefficient (total head)
C_v	—	coefficient of velocity
E	m	encoder height from datum
e_b	m	random uncertainty in the width measurement
g	m/s^2	acceleration due to gravity
H	m	total head above crest level
h	m	gauged head above crest level (upstream head is inferred if no subscript is used)
L	m	length of weir in the direction of flow
n	—	number of measurements in a set
p	m	height of weir (difference between mean bed level and crest level)

Q	m ³ /s	volumetric rate of flow
S	—	submergence ratio, h_2/h_1
S_1	—	modular limit
\bar{v}_1	m/s	mean velocity in the approach channel
U	%	expanded percentage uncertainty
$u^*(b)$	%	percentage uncertainty in b
$u^*(C)$	%	percentage uncertainty in C
$u^*(h_1)$	%	percentage uncertainty in h_1
$u^*(Q)$	%	percentage uncertainty in Q

Subscripts

- 1 upstream
- 2 downstream
- c combined
- E encoder
- t distance between the (upstream) gauged head and the encoder

5 Installation

5.1 General

The conditions regarding the preliminary survey, selection of site, installation, approach channel, maintenance, measurement of the head, and stilling or float wells, which are generally necessary for flow measurement, are given in 5.2, 5.3, 6 and 7. The particular requirements for the rectangular broad-crested weir are given separately in Clause 8.

5.2 Selection of site

A preliminary survey shall be made of the physical and hydraulic features of the proposed site to check that it conforms (or can be made to conform) to the requirements necessary for accurate flow measurement by the weir.

Particular attention shall be paid to the following features in selecting the site for the weir:

- a) the availability of an adequate length of channel of regular cross-section;
- b) the existing velocity distribution;
- c) the avoidance of a steep channel, if possible (see 5.3.2);
- d) the effects of any increased upstream water level due to the measuring structure;
- e) the conditions downstream, including influences such as tides, confluences with other streams, sluice gates, mill dams and other controlling features, which might cause drowning;
- f) the impermeability of the ground on which the structure is to be founded, and the necessity for piling, grouting or other means of controlling seepage;
- g) the necessity for flood banks to confine the maximum discharge to the channel;

- h) the stability of the banks, and the necessity for trimming and/or revetment in natural channels;
- i) the clearance of rocks or boulders from the bed of the approach channel;
- j) the effects of wind, which can have a considerable effect on the flow in a river, or over a weir, especially when the river or weir is wide and the head is small and when the prevailing wind is in a transverse direction.

If the site does not possess the characteristics necessary for satisfactory measurements, the site shall be rejected unless suitable improvements are practicable.

If an inspection of the stream shows that the existing velocity distribution is regular, then it may be assumed that the velocity distribution will remain satisfactory after the construction of the weir.

If the existing velocity distribution is irregular and no other site for a gauge is feasible, due consideration shall be given to checking the distribution after the installation of the weir and to improving it if necessary.

Several methods are available for obtaining a more precise indication of irregular velocity distribution. These include velocity rods, floats or concentrations of dye, which can be used in small channels; the last is useful to check the conditions at the bottom of the channel. A complete and quantitative assessment of the velocity distribution may be made by means of a current-meter or other point velocity instruments. More information about the use of current-meters is given in ISO 748 [1]. Further information on measuring river velocities using acoustic Doppler profilers can be found in ISO/TS 24154 [3].

5.3 Installation conditions

5.3.1 General

The complete measuring installation consists of an approach channel, a measuring structure and a downstream channel. The conditions of each of these three components affect the overall accuracy of the measurements.

Installation requirements include features such as the surface finish of the weir, the cross-sectional shape of the channel, the channel roughness, and the influence of control devices upstream or downstream from the gauging structure.

The distribution and direction of velocity have an important influence on the performance of a weir, these factors being determined by the features mentioned above.

Once a weir has been installed, the user shall prevent any changes which could affect the discharge characteristics.

5.3.2 The approach channel

On all installations, the flow in the approach channel shall be smooth, free from disturbance and have a velocity distribution as satisfactory as possible over the cross-sectional area. This can usually be verified by inspection or measurement. In the case of natural streams or rivers, this can only be attained by having a long straight approach channel free from projections into the flow. The following general requirements shall be complied with.

- a) The altered flow conditions owing to the construction of the weir might cause a build-up of shoals of debris upstream of the structure, which in time might affect the flow conditions. The likely consequential changes in the water level shall be taken into account in the design of gauging stations.
- b) In an artificial channel, the cross-section shall be uniform and the channel shall be straight for a length equal to at least 5 times its water-surface width.

- c) In a natural stream or river, the cross-section shall be reasonably uniform and the channel shall be straight for a sufficient length to ensure a regular velocity distribution.
- d) If the entry to the approach channel is through a bend, or if the flow is discharged into the channel through a conduit or a channel of smaller cross-section, or at an angle, then a longer length of straight approach channel may be required to achieve a regular velocity distribution.
- e) Baffles shall not be installed closer to the points of measurement than a distance 10 times the maximum head to be measured.
- f) Under certain conditions, a standing wave may occur upstream of the gauging device, e.g. if the approach channel is steep. Provided that this wave is at a distance of not less than 30 times the maximum head upstream, flow measurement is feasible, subject to confirmation that a regular velocity distribution exists at the gauging station and that the Froude number in this section is no more than 0,6. Ideally, high Froude numbers should be avoided for accurate flow measurement.

If a standing wave occurs within this distance, the approach conditions and/or the gauging device shall be modified.

5.3.3 The measuring structure

The structure shall be rigid and watertight and capable of withstanding flood flow conditions without distortion or fracture. It shall be at right angles to the direction of flow and shall conform to the dimensions given in the relevant clauses.

5.3.4 Downstream of the structure

If the downstream channel is rectangular and of the same width as the weir for a distance equal to twice the maximum head downstream from the downstream face of the weir, then it is not necessary to ventilate the nappe, particularly for high values of h_1/L .

The channel further downstream from the structure is usually of no importance as such, provided that the weir has been designed to ensure that the flow is modular (i.e. unaffected by tailwater level) under all operating conditions.

However, the water level may be raised sufficiently to drown the weir if the altered flow conditions due to the construction of the weir cause the build-up of shoals of debris immediately downstream of the structure or if river works are carried out at a later date.

Any accumulation of debris downstream of the structure shall therefore be removed.

6 General maintenance requirements

Maintenance of the measuring structure and the approach channel is important to secure continued accuracy of the measurements.

In the event of the possibility of scouring downstream, which may lead to instability of the structure, particular measures to prevent this happening may be required.

It is essential that the approach channel to weirs be kept clean and free from silt and vegetation as far as practicable for at least the distance specified in 5.3.2. The float well and the entry from the approach channel shall also be kept clean and free from deposits.

The weir shall be kept clean and free from clinging debris and care shall be taken in the process of cleaning to avoid damage to the weir crest.

7 Measurement of head(s)

7.1 General

The head upstream of the measuring structure may be measured by a hook gauge, point gauge or staff gauge where spot measurements are required or by a recording gauge where a continuous record is required. In many cases, it is preferable to measure heads in a separate stilling well to reduce the effects of surface irregularities.

The discharges calculated using the working equation are volumetric figures, and the liquid density does not affect the volumetric discharge for a given head provided that the operative head is gauged using a liquid of identical density. If the gauging is carried out in a separate well, correction for the difference in density may be necessary if the temperature of the liquid in the well is significantly different from that of the flowing liquid. However, it is assumed herein that the densities are equal.

It shall, however, be ensured that the gauge is not located in a pocket or still pool, but that it measures the piezometric head.

7.2 Stilling or float well

Where provided, the stilling well shall be vertical and, for field installations, shall extend at least 0,6 m above the maximum estimated water level.

Stilling wells shall be connected to the channel by an inlet pipe, or slot, large enough to permit the water in the well to follow the rise and fall of the head without significant delay. For field installations, the level of the inlet pipe shall be at least 0,1 m below minimum water level.

The connecting pipe or slot shall, however, be as small as possible with regard to ease of maintenance. Alternatively, the connecting pipe or slot shall be fitted with a constriction to damp out oscillations due to short amplitude waves.

The well and the connecting pipe or slot shall be watertight. The well shall be of adequate diameter and depth to accommodate the float of a level recorder, if used.

The well shall also be deep enough to accommodate any sediment which may enter, without the float grounding. The float well arrangement may include an intermediate chamber between the stilling well and the approach channel, of similar proportions to those of the stilling well to enable sediment to settle out. For ease of maintenance, the pipework may be fitted with valves.

More detailed information on the stilling well may be obtained from ISO 1100-1 [2].

7.3 Zero setting

A means of checking the zero setting of the head measuring device shall be provided, consisting of a datum related to the level of the weir crest.

A zero check based on the level of the water when the flow ceases is liable to incur serious errors from surface tension effects and shall not be used.

With decreasing size of the weir and the head, small errors in construction and in the zero setting and reading of the head measuring device become of greater importance.

8 Rectangular broad-crested weirs

8.1 Specification for the standard weir

The crest of the standard weir shall be a smooth, horizontal, rectangular plane surface (in these specifications a "smooth" surface shall have a surface finish equivalent to that of rolled sheet metal). The width of the crest perpendicular to the direction of flow shall be equal to the width of the channel in which the weir is located. The upstream and downstream end faces of the weir shall be smooth, plane surfaces and they shall be perpendicular to the sides and the bottom of the channel in which the weir is located. The upstream face, in particular, shall form a sharp right-angle corner at its intersection with the plane of the crest.

If the upstream corner of the weir is slightly rounded, the discharge coefficient can increase significantly.

A typical sketch of the weir is shown in Figure 1.

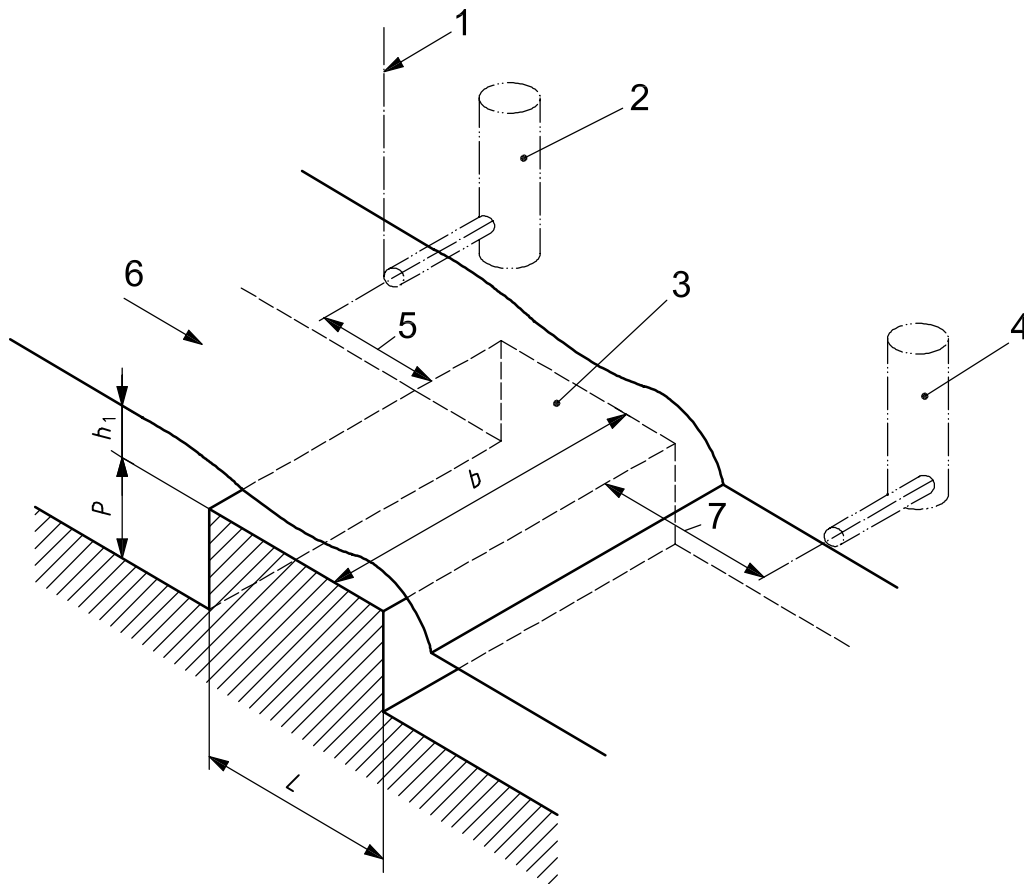

Key

- 1 head gauging station
- 2 upstream stilling well
- 3 horizontal crest
- 4 downstream stilling well
- 5 $3h_{1,max}$ to $4h_{1,max}$
- 6 flow
- 7 $10h_{1,max}$

Figure 1 — Rectangular broad-crested weir

8.2 Location of the head gauge section

8.2.1 Upstream head measurement

Piezometers or a point-gauge station for the measurement of the head on the weir shall be located at a sufficient distance upstream from the weir to avoid the region of surface drawdown. They (or it) shall, however, be close enough to the weir for the energy loss between the section of the measurement and the control section on the weir to be negligible. It is recommended that the head measurement section be located at a distance equal to three to four times the maximum head (i.e. $3 h_{1,\max}$ to $4 h_{1,\max}$) upstream from the upstream face of the weir.

8.2.2 Downstream head measurement

If the weir is to be operated in the drowned flow range, a measurement of downstream head is required. The downstream head measurement position shall be $10h_{1,\max}$ downstream from the face of the weir. At this location, the turbulence associated with energy dissipation near to the weir has subsided to an acceptable level. The downstream head measurement position should be located within the parallel sidewalls of the weir structure.

8.3 Provision for modular flow

Flow over a rectangular broad-crested weir is not affected by tailwater levels if the crest level is chosen such that the submergence ratio, $S = \frac{h_2}{h_1}$, does not exceed the modular limit. The modular limit is given in Annex A.

9 Discharge relationships

9.1 Modular flow discharge equation

The equation of discharge is based on the use of a gauged head:

$$Q = \left(\frac{2}{3}\right)^{3/2} g^{1/2} b C h_1^{3/2} \quad (1)$$

where

- Q is the volumetric rate of flow;
- g is the acceleration due to gravity;
- b is the width of the weir perpendicular to the direction of flow;
- C is the gauged head discharge coefficient;
- h_1 is the upstream gauged head related to the crest elevation.

9.2 Modular coefficient of discharge

The gauged head discharge coefficient, C , is given in Figure 2 and Table 1 as a function of h_1/L and h_1/p , where L is the length of the weir in the direction of flow and p is the height of the weir with respect to the bottom of the approach channel.

Intermediate values of C may be obtained by linear interpolation.

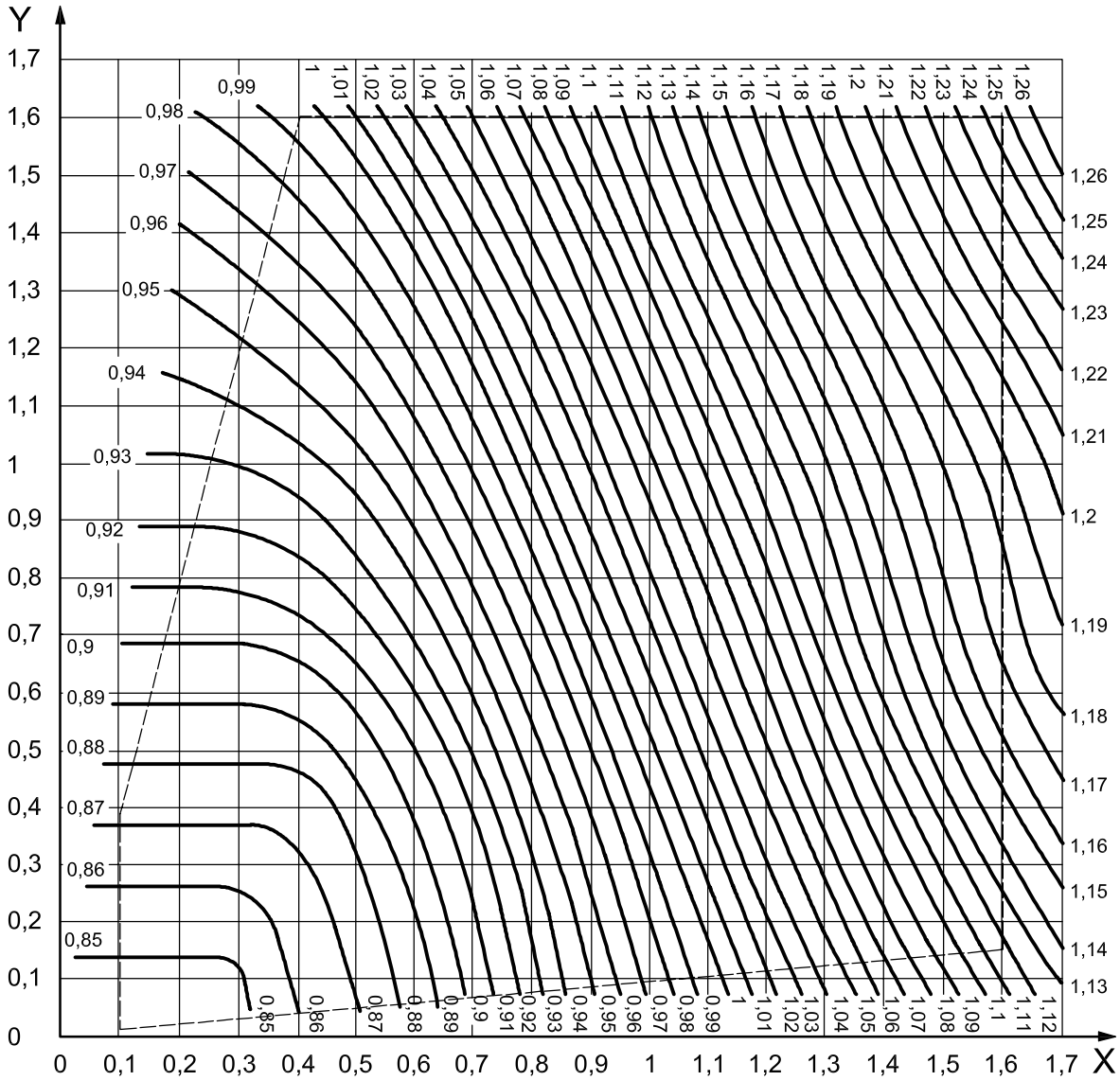

NOTE For the meaning of the dashed lines, see 9.3.

Key

X h_1/L

Y h_1/p

Figure 2 — Coefficient of discharge, C , in terms of h_1/p and h_1/L

Table 1 — Gauged head discharge coefficients

h_1/p	C for the following values of h_1/L																	
	0,1	0,2	0,3	0,4	0,5	0,6	0,7	0,8	0,9	1,0	1,1	1,2	1,3	1,4	1,5	1,6	1,7	1,8
0,1	0,850	0,850	0,850	0,861	0,870	0,885	0,893	0,925	0,948	0,971	0,993	1,016	1,039	1,062	1,085	1,106	1,130	1,148
0,2	0,855	0,855	0,855	0,864	0,874	0,888	0,907	0,930	0,954	0,977	1,001	1,026	1,050	1,074	1,096	1,120	1,142	1,159
0,3	0,864	0,864	0,864	0,868	0,879	0,894	0,913	0,936	0,961	0,986	1,011	1,037	1,061	1,085	1,110	1,132	1,152	1,169
0,4	0,873	0,873	0,873	0,874	0,885	0,901	0,920	0,945	0,969	0,995	1,021	1,047	1,072	1,097	1,122	1,144	1,163	1,180
0,5	0,882	0,882	0,882	0,883	0,894	0,909	0,929	0,954	0,978	1,005	1,032	1,057	1,083	1,109	1,133	1,154	1,173	1,188
0,6	0,892	0,892	0,892	0,894	0,904	0,920	0,941	0,964	0,990	1,016	1,043	1,067	1,094	1,120	1,143	1,164	1,182	1,196
0,7	0,901	0,901	0,901	0,906	0,916	0,932	0,952	0,975	1,000	1,026	1,052	1,077	1,104	1,129	1,152	1,171	1,188	1,203
0,8	0,911	0,911	0,912	0,916	0,926	0,942	0,962	0,985	1,010	1,036	1,062	1,086	1,112	1,136	1,158	1,176	1,194	1,209
0,9	0,921	0,921	0,922	0,926	0,936	0,952	0,972	0,996	1,020	1,046	1,072	1,096	1,120	1,143	1,163	1,181	1,199	1,214
1,0	0,929	0,929	0,931	0,936	0,946	0,962	0,982	1,006	1,031	1,056	1,081	1,106	1,128	1,150	1,169	1,187	1,204	1,220
1,1	0,935	0,937	0,940	0,946	0,956	0,972	0,993	1,017	1,042	1,066	1,092	1,115	1,138	1,159	1,177	1,195	1,212	1,228
1,2	0,941	0,944	0,949	0,956	0,966	0,982	1,004	1,028	1,053	1,077	1,103	1,126	1,148	1,168	1,186	1,204	1,222	1,237
1,3	0,946	0,951	0,957	0,966	0,977	0,993	1,016	1,040	1,063	1,089	1,114	1,136	1,158	1,178	1,196	1,214	1,232	1,250
1,4	0,953	0,959	0,967	0,975	0,986	1,005	1,028	1,050	1,075	1,101	1,124	1,147	1,168	1,187	1,206	1,224	1,244	1,266
1,5	0,961	0,968	0,975	0,984	0,997	1,018	1,040	1,061	1,086	1,111	1,134	1,156	1,176	1,196	1,215	1,235	1,258	1,277
1,6	0,972	0,978	0,985	0,994	1,010	1,030	1,050	1,073	1,096	1,119	1,142	1,164	1,184	1,204	1,224	1,245	1,268	1,289

NOTE The recommended limits of application are those values which appear within the unshaded area.

The coefficient of discharge, C , has a constant value of 0,85 in the range $0,1 \leq h_1/L \leq 0,3$ and for $h_1/p < 0,15$.

On the basis of the variation in C with h_1/L , a distinction can be made between the following types of flow (see Figure 3):

- a) broad-crested flow, $0,1 \leq h_1/L \leq 0,4$: the flow across the weir is parallel to the crest for a certain portion;
- b) short-crested flow, $0,4 \leq h_1/L \leq 1,6$: the flow is totally curvilinear.



Figure 3 — Flow patterns over rectangular broad- and short-crested weirs

9.3 Limitations for operation in the modular flow range

The following general limitations are recommended.

To avoid surface tension and viscous effects, $h_1 \geq 0,06$ m, $b \geq 0,30$ m and $p \geq 0,15$ m.

There are no calibration data available beyond the practical limits $0,1 < L/p < 4,0$ and $0,1 < h_1/L < 1,6$.

To avoid unstable water levels, $h_1/p < 1,6$.

These limitations have been indicated on Figure 2 by dashed lines.

9.4 Drowned flow discharge equation

Drowned flow performance data is available for a specific but typical geometry for the rectangular broad-crested weir. For weirs where the length (in the direction of flow) to height ratio is approximately 3, the following equations define the drowned flow performance.

$$Q = (2/3)^{3/2} g^{1/2} b f C h_1^{3/2} \tag{2}$$

where f , the drowned flow reduction factor, is defined in terms of total head as follows:

$$f = 1,045 \left[0,76 - (H_2/H_1)^{4,2} \right]^{0,0645} \text{ in the range } 0,750 < H_2/H_1 < 0,925$$

and

$$f = 5,70 - 5,245 (H_2/H_1) \text{ in the range } 0,925 < H_2/H_1 < 0,975$$

NOTE The distinction between the gauged head discharge coefficient and the total head discharge coefficient is explained in Annex B.

9.5 Limitations for operation in the drowned flow range

The following general limitations are recommended to avoid surface tension and viscous effects:

$$h_1 \geq 0,06 \text{ m; } b \geq 0,30 \text{ m; and } p \geq 0,15 \text{ m.}$$

The drowned flow calibration data presented in this International Standard apply only to weirs where $L/p = 3,0 \pm 0,2$.

Calibration data are not available for the drowned flow reduction factor outside the range covered by research, namely $1,0 \geq f \geq 0,6$. The corresponding range of head ratios is $0,750 \leq H_2/H_1 \leq 0,975$.

10 Uncertainties in flow measurement

10.1 General

This clause provides information for the user of this International Standard to state the uncertainty of a measurement of discharge.

Annex C is an introduction to measurement uncertainty. It provides supporting information based on the *Guide to the expression of uncertainty in measurement* (hereafter referred to as the GUM) [6] and ISO/TS 25377 (hereafter referred to as the HUG) [4]. Refer to Annex C for definitions.

Former versions of this International Standard have expressed the uncertainty of discharge coefficient $u(C)$ at the 95 % level of confidence. This is equivalent to two standard deviations, or twice the value of standard uncertainty.

This International Standard expresses discharge coefficient as standard uncertainty (one standard deviation) to be in accordance with the GUM.

Hydrometry requires measurements using various techniques, the results of which are used to calculate a value for flow. Annex D provides sample values for the various techniques. These are presented in tabular form with uncertainty estimates ascribed to each technique for the purpose of illustration only.

These sample values are not to be interpreted as norms of performance. In practice, manufacturer's data, preferably supported by formal certification (ISO/IEC 17025) [5], shall be used.

The example given in Clause 11 uses values from Annex D.

10.2 Statement of the uncertainty of a flow measurement in a channel

10.2.1 A measurement result comprises

- i) an estimate of the measured value, with
- ii) a statement of the uncertainty of the measurement.

10.2.2 A statement of the uncertainty of a flow measurement in a channel has four separate components of uncertainty:

- i) uncertainty of the measurement of head in the channel;
- ii) uncertainty of the dimensions of the structure;
- iii) uncertainty of the discharge coefficient stated in this International Standard from laboratory calibration of the flow structure being considered;
- iv) uncertainty of channel velocity distribution related to the velocity coefficient, C_v .

This clause does not accommodate component iv).

It is assumed that the channel hydraulics are substantially equivalent to those existing in the calibration facility at the time of derivation of component iii), as defined in 5.3.2.

The estimation of measurement uncertainty associated with items i) and ii) of this subclause is provided in Annex D.

Values taken from Annex D are used in the example in Clause 11. These values are for illustrative purposes only, they should not be interpreted as norms of performance for the types of equipment listed. In practice, uncertainty estimates should be taken from test certificates for the equipment, preferably obtained from a laboratory accredited in accordance with ISO/IEC 17025.

10.3 Combining measurement uncertainties

Refer to C.7.

The proportion in which each flow equation parameter contributes to flow measurement uncertainty, $U(Q)$, is derived by analytical solution using partial differentials of the discharge equation.

The equation of discharge stated in 9.1 [Equation (1)] for modular flow is:

$$Q = \left(\frac{2}{3}\right)^{3/2} g^{1/2} b C h_1^{3/2}$$

The effect on the value Q due to small dispersions of ΔC , Δb and Δh_1 is given by Equation (3):

$$\Delta Q = \frac{\partial Q}{\partial C} \Delta C + \frac{\partial Q}{\partial b} \Delta b + \frac{\partial Q}{\partial h_1} \Delta h_1 \tag{3}$$

where the partial derivatives are the sensitivity coefficients of C.7 that relate to the discharge equation. ΔC is the resultant dispersion of Q . Evaluating the partial differentials and using Equation (1), the relationship can be written:

$$\frac{\Delta Q}{Q} = \frac{\Delta C}{C} + \frac{\Delta b}{b} + 1,5 \frac{\Delta h_1}{h_1} \tag{4}$$

Thus, the relative sensitivity coefficients are:

$$\frac{\partial Q}{\partial C} = 1$$

$$\frac{\partial Q}{\partial b} = 1$$

$$\frac{\partial Q}{\partial h_1} = 1,5$$

The values $\frac{\Delta Q}{Q}$, $\frac{\Delta b}{b}$, $\frac{\Delta C}{C}$ and $\frac{\Delta h_1}{h_1}$ are dimensionless standard uncertainties and are given the notation $u^*(Q)$, $u^*(C)$, $u^*(b)$ and $u^*(h)$.

Since the uncertainties of b , C and h are independent of each other, probability requires summation in quadrature. See Equation (5):

$$u^*(Q) \cong \sqrt{u^*(C)^2 + u^*(b)^2 + [1,5u^*(h)]^2} \tag{5}$$



10.4 Uncertainty of discharge coefficient $u(C)$ for the broad-crested weir

10.4.1 General

The discharge coefficient C of Equation (1) has been determined from a series of hydraulic tests using a high-resolution calibration facility.

10.4.2 Modular flow measurement uncertainty

For broad-crested weirs constructed to within the tolerances stated in 8.1 and installed in a channel in which the approach conditions comply with those given in 5.3.2, the relative standard uncertainty of the coefficient of discharge C is given by Equation (6):

$$u^*(C) = \left[0,75 + 0,5 \left(\frac{h_1}{p} \right)^2 \right] \% \quad (6)$$

10.4.3 Drowned flow measurement uncertainty

Similarly, for broad-crested weirs constructed to within the tolerances stated in 8.1 and installed in a channel in which the approach conditions comply with those stated in 5.3.2, but where drowned flow occurs, the relative standard uncertainty of the coefficient of discharge C is given by Equation (7):

$$u^*(C) = \left[\frac{0,75}{C^3} + 0,5 \left(\frac{h_1}{p} \right)^2 \right] \% \quad (7)$$

10.5 Uncertainty budget

In reports, an uncertainty budget table may be presented (or referenced) to provide the following information for each source of uncertainty:

- a) the method of evaluation (from Annex C);
- b) the determined value of standard uncertainty for $u^*(C)$, $u^*(b)$ and $u^*(h)$ including datum uncertainty of $u^*(h_1)$;
- c) the relative sensitivity coefficients.

The values for each source are then applied according to Equation (5) to give the relative combined standard uncertainty, $u_c^*(Q)$.

The expanded uncertainty $u(Q)$ for a confidence level of 95 % is calculated using Table C.1.

It is customary to present these steps in tabular form with one row for each source and a column for each of the items a) to c) above. The table may include, where appropriate, the critical thinking behind the subjective allocation of uncertainty to the quantities b and h . This section of the table may be replicated for a range of values of h_1 to determine a relationship between $u^*(Q)$ and h_1 .

11 Example

11.1 General

In presenting examples, the equation given in 9.1 defines the relationship between the parameters which determine flow rate.

Uncertainty of the discharge coefficient is a fundamental uncertainty and is defined by Equations (6) and (7). To complete an overall uncertainty estimation, practical estimations shall be made of the head measurement uncertainty and the uncertainty of the measurement of physical dimensions.

Annex C provides a consistent framework for evaluating these uncertainties for the commonly used measurement techniques.

One such technique is selected in 11.3 for the example that follows.

11.2 Characteristics — Gauging structure

The example relates to modular flow conditions. The crest height p above the bed of the approach channel is 0,300 m with a variation along its length from 0,294 m to 0,306 m. The width of the weir crest varies from a minimum value of 1,265 m to a maximum of 1,280 m. The approach channel is assumed to be of the same width as the mean width of the weir (1,272 5 m). The length L of the weir in the direction of flow is 0,5 m.

11.3 Characteristics — Gauged head instrumentation

In this example, a float system is used to determine head:

- a) The encoder is fixed at an elevation of 1,422 m above the hydraulic datum (the mean level of the weir crest). Referring to Annex D, the relative datum uncertainty is:

$$u(E) = 0,001 5 \text{ m.}$$

- b) The gauged head, h_1 , is 0,400 m relative to hydraulic datum. The extension of the float tape is therefore to a distance of $h_E = 1,022$ m below the encoder. Referring to Annex D, the normal performance for a float system is presented in Table 2, from which the standard uncertainty (at 1,022 m) is:

$$u(h_1) = 0,001 9 \text{ m}$$

Table 2 — Example — Normal float performance

	Minimum	25 %	50 %	75 %	Maximum
Rating	Extension 0,200 m	Extension 1,250 m	Extension 2,500 m	Extension 3,750 m	Extension 5,000 m
$u(h_1)$	0,001 5 m	0,002 0 m	0,002 0 m	0,002 5 m	0,002 5 m

NOTE If the crest is liable to accumulate algal or other growth, the uncertainty value of head measurement needs to be increased accordingly.

11.4 The discharge coefficient

The value of the gauged head discharge coefficient (for the corresponding values of $h_1/L = 0,8$ m with $h_1/p = 1,333$ m and $L/p = 1,667$ m) is determined from Figure 2 or Table 1 to be

$$C = 1,043$$

11.5 The discharge estimate

The flow rate is calculated from Equation (1) in 9.1:

$$Q = \left(\frac{2}{3}\right)^{3/2} g^{1/2} b C h_1^{3/2}$$

$$Q = 0,544\ 3 \times 3,132\ 1 \times 1,043 \times 1,272\ 5 \times 0,253\ 0$$

$$= 0,572\ \text{m}^3/\text{s}$$

11.6 Uncertainty statement

11.6.1 From Equation (6), the value for uncertainty of the discharge coefficient is:

$$u^*(C) = 0,75 + 0,5 \left(\frac{0,4}{0,3} \right)^2$$

$$= 1,64\ \%$$

11.6.2 Using Equation (C.4), the value of uncertainty of the width of the weir may be written:

$$u(b) = \frac{1}{\sqrt{6}} \left(\frac{\text{Maximum width} - \text{Minimum width}}{2} \right)$$

$$u(b) = \frac{1}{\sqrt{6}} \left(\frac{1,280 - 1,265}{2} \right)$$

$$u(b) = 0,003\ 06\ \text{m}$$

or

$$u^*(b) = \frac{0,003\ 06}{1,272\ 5} \times 100$$

$$u^*(b) = 0,24\ \%$$

11.6.3 From 11.3, the combined uncertainty of gauged head $u(h)$ is determined from instrumentation measurement uncertainty and datum measurement uncertainty:

$$u(h) = \sqrt{0,001\ 6^2 + 0,001\ 9^2}$$

$$u(h) = 0,002\ 5\ \text{m}$$

$$u^*(h) = \frac{0,002\ 5}{0,4} \times 100$$

$$u^*(h) = 0,62\ \%$$

11.6.4 The combined uncertainty value is determined from Equation (5) in 10.3:

$$u_c^*(Q) = \sqrt{u^*(C)^2 + u^*(b)^2 + [1,5u^*(h)]^2}$$

$$u_c^*(Q) = \sqrt{1,64^2 + 0,24^2 + (1,5 \times 0,62)^2}$$

$$u_c^*(Q) = 1,9\ \%$$

$$U_c^*(Q) = 3,8\ \% \text{ at the 95\ \% level of confidence.}$$

11.6.5 The calculations used in this example are summarized in Table 3 (the uncertainty budget).

Table 3 — An uncertainty budget for the example

	Type ^a /Evaluation	u, u^* value	Sensitivity coefficients	Comment
$u^*(C_d)$	B/Normal	1,64 %	1,0	From laboratory tests
$u^*(b)$	B/Triangular	0,24 %	1,0	Using C.6.2
$u(E)$	B/Triangular	0,001 5 m	—	From Annex D
$u(h_t)$	B/Bimodal	0,001 9 m	—	From Table 2
$u^*(h_1)$	Combined	0,62 %	1,5	From 11.6.3
$u_c^*(Q)$	Combined	1,9 %	—	Using Equation (5)

^a See C.4 for an explanation of type.

11.6.6 The conventional statement of discharge is therefore:

0,572 m³/s with an uncertainty of 3,8 % at the 95 % level of confidence based on a coverage factor of $k = 2$.

Annex A (informative)

Modular limit

Submerged flow will not occur as long as the modular limit is not exceeded.

The modular limit S_1 is defined as the submergence ratio $S = h_2/h_1$ for which the deviation between the submerged flow calculated with the free-flow head discharge equation [Equation (1)] and the real flow is 1 %, i.e.

if $S \leq S_1$, the flow is free flow, and

$S > S_1$, the flow is drowned flow.

h_2 is defined as the downstream gauged head above crest level.

Figure A.1 shows the modular limit.

Theoretically, the modular limit also depends on h_1/p . Therefore, the values for S_1 given in Figure A.1 should be considered to be minimum values.

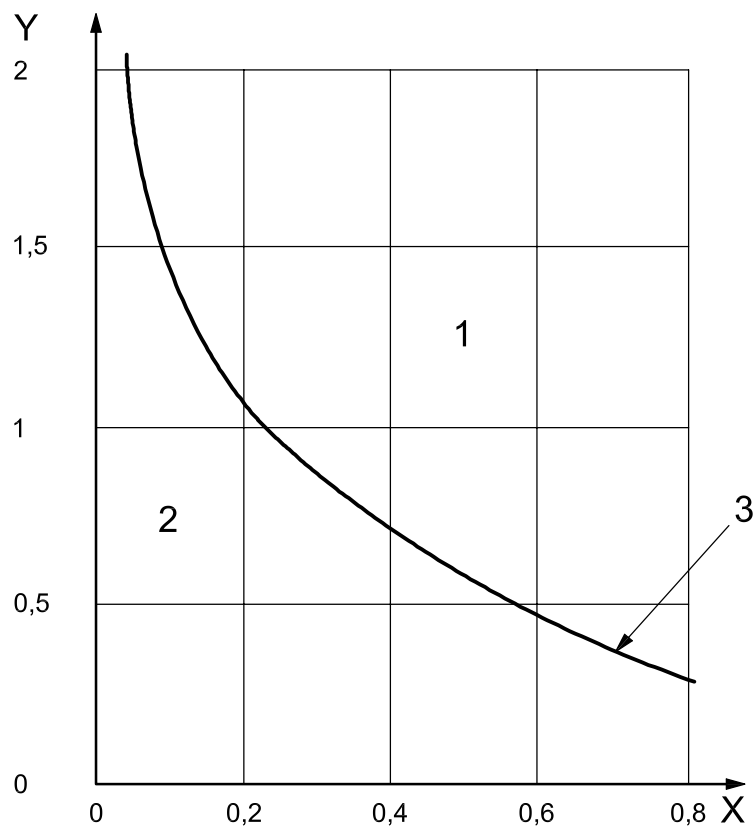

Key

- 1 submerged flow
- 2 free flow
- 3 modular limit, S_1

X $S = h_2/h_1$

Y h_1/L

Figure A.1 — Modular limit S_1 as a function of h_1/L

Annex B (informative)

Gauged head discharge coefficient and total head discharge coefficient

Distinction should be made between the gauged head discharge coefficient and the total head discharge coefficient.

The gauged head discharge coefficient is given by

$$C = \frac{Q}{\left(\frac{2}{3}\right)^{3/2} g^{1/2} b h_1^{3/2}} \quad (\text{B.1})$$

The head h_1 is measured in the rectangular approach channel, as indicated in Figure 1.

The total head discharge coefficient is given by

$$C_d = \frac{Q}{\left(\frac{2}{3}\right)^{3/2} g^{1/2} b C_v h_1^{3/2}} \quad (\text{B.2})$$

where C_v is the velocity of approach factor, introduced to correct the gauged head, given by

$$C_v = \left(\frac{H_1}{h_1}\right)^{3/2} \quad (\text{B.3})$$

where H_1 is the upstream total head with respect to the crest elevation, i.e.

$$H_1 = h_1 + \frac{\bar{v}_1^2}{2g} \quad (\text{B.4})$$

where \bar{v}_1 is the mean velocity in the approach channel.

The head h_1 can be measured in any shape of approach channel.

The relation between the gauged head coefficient C and the total head coefficient C_d is given by

$$C = C_d C_v \quad (\text{B.5})$$

The gauged head discharge coefficient C is given in Figure 2.

Annex C (informative)

Introduction to measurement uncertainty

C.1 General

Results of measurements or analysis cannot be exact. The discrepancy between the true value, which is unknowable, and the measured value is the measurement error. The concept of uncertainty is a way of expressing this lack of knowledge. For example, if water is controlled to flow at a constant rate, then a flow meter will exhibit a spread of measurements about a mean value. If attention is not given to the uncertain nature of data, incorrect decisions can be made which have financial or judicial consequences. A realistic statement of uncertainty enhances the information, making it more useful.

The uncertainty of a measurement represents a dispersion of values that could be attributed to it. Statistical methods provide objective values based on the application of theory.

Standard uncertainty is defined as follows:

Standard uncertainty equates to a dispersion of measurements expressed as a standard deviation.

From this definition, uncertainty can be readily calculated for a set of measurements.

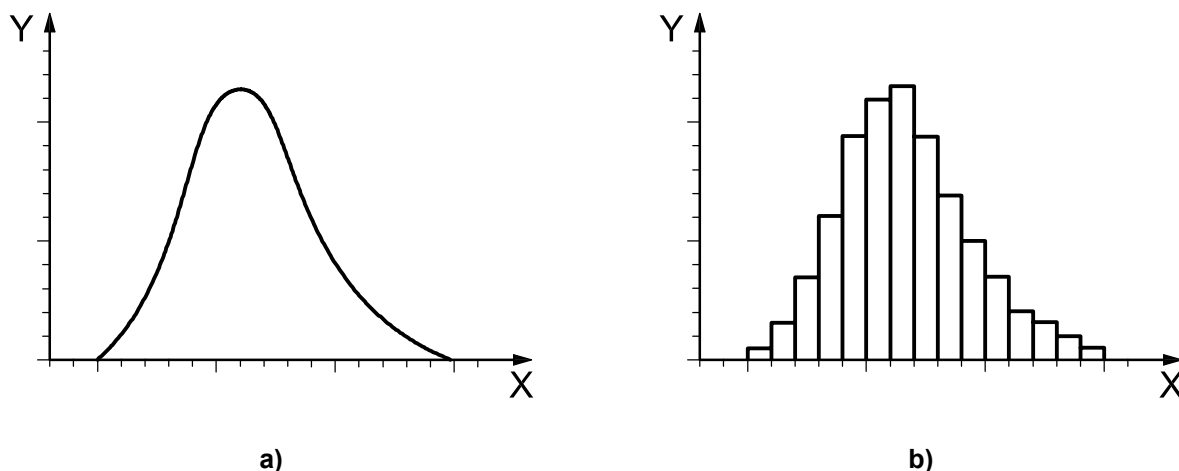

Key

X flow value
Y probability

Key

X flow value
Y number of samples

Figure C.1 (continued)

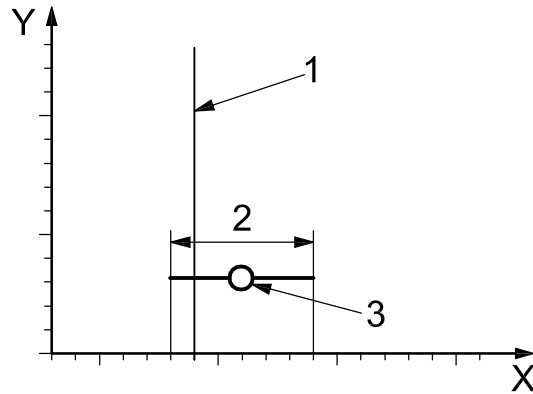

c)

Key

- 1 limit
- 2 standard deviation
- 3 mean value

- X flow value
- Y number of samples

Figure C.1 — Pictorial representation of some uncertainty parameters

Figure C.1 a) shows the probability that a measurement of flow under steady conditions takes a particular value due to the uncertainties of various components of the measurement process

Figure C.1 b) shows sampled flow measurements.

Figure C.1 c) shows standard deviation of the sampled measurements compared with a limiting value. The mean value is shown to exceed the limiting value but is within the band of uncertainty (expressed as the standard deviation about the mean value).

C.2 Confidence limits and coverage factors

For a normal probability distribution, analysis shows that 68 % of a large set of measurements lie within one standard deviation of the mean value. Thus, standard uncertainty is said to have a 68 % level of confidence.

However, for some measurement results, it is customary to express the uncertainty at a level of confidence which will cover a larger portion of the measurements: for example at a 95 % level of confidence (see Figure C.4). This is done by applying a factor, the coverage factor *k*, to the computed value of standard uncertainty.

For a normal probability distribution, 95,45 % (effectively 95 %) of the measurements are covered for a value of *k* = 2. Thus, uncertainty at the 95 % level of confidence is twice the standard uncertainty value.

In practice, measurement variances rarely follow closely the normal probability distribution. They may be better represented by triangular, rectangular or bimodal probability distributions and only sometimes approximate to the normal distribution.

So a probability distribution needs to be selected to model the observed variances. To express the uncertainty of such models at the 95 % confidence limit requires a coverage factor that represents 95 % of the observations. However, the same coverage factor, *k* = 2, is used for all models. This simplifies the procedure while ensuring consistency of application within tolerable limits.

C.3 Random and systematic error

The terms “random” and “systematic” have been applied in hydrometric standards to distinguish between

- i) random errors that represent an inherent dispersion of values under steady conditions, and
- ii) systematic errors that are associated with inherent limitations of the means of determining the measured quantity.

A difficulty with the concept of systematic error is that systematic error cannot be determined without prior knowledge of true values. If its existence is known or suspected, then steps must be taken to minimize such error either by recalibration of equipment or by reversing its effect in the calculation procedure. At this point, systematic error contributes to uncertainty in the same way as random components of uncertainty.

For this reason, the GUM does not distinguish between the treatment of random and systematic uncertainties. Generally, when determining a single discharge, random errors dominate and there is no need to separate random and systematic errors. However, where (say) totalized volume is established over a long time base, the systematic error, even when reduced, can remain dominant in the estimation of uncertainty.

C.4 Measurement standards

The GUM and the HUG provide rules for the application of the principles of measurement uncertainty, in particular on the identification of components of error, the quantification of their corresponding uncertainties and how these are combined using methods derived from statistical theory into an overall result for the measurement process.

The components of uncertainty are characterized by estimates of standard deviations. There are two methods of estimation:

- a) **Type-A estimation** (by statistical analysis of repeated measurements from which an equivalent standard deviation is derived).

This process may be automated in real-time for depth or for velocity measurement.

- b) **Type-B estimation** (by ascribing a probability distribution to the measurement process).

This is applicable to

- 1) human judgement of a manual measurement (distance or weight),
- 2) manual readings taken from instrumentation (manufacturer's statement), or
- 3) calibration data (from manufacturer).

C.5 Evaluation of Type-A uncertainty

Defined in C.1, the term “standard uncertainty” equates to a dispersion of measurements expressed as a standard deviation. Thus, any single measurement of a set of n measurements has by definition an uncertainty:

$$u(x) = t_e \sqrt{\frac{1}{n-1} \sum_{i=1}^n (x_i - \bar{x})^2} \quad (\text{C.1})$$

where \bar{x} , the best estimate, is the true mean:

$$\bar{x} = \frac{1}{n} (x_1 + x_2 + \dots + x_n) \quad (\text{C.2})$$

and t_e is a factor derived from statistical theory to account for the increased uncertainty when small numbers of measurements are available; refer to Table C.1.

If, instead of a single measurement from the set, the uncertainty is to apply to the mean of all n values then:

$$u(\bar{x}) = \frac{t_e}{\sqrt{n}} \sqrt{\frac{1}{n-1} \sum_{i=1}^n (x_i - \bar{x})^2} \tag{C.3}$$

For continuous measurement, Type-A evaluations may be derived as a continuous variable from the primary measurement, i.e. from water level or water velocity.

By taking average values over large numbers, n , of measurements, the uncertainty of the mean value $u(\bar{x})$ is reduced by a factor of $\frac{1}{\sqrt{n}}$ compared to the uncertainty $u(x)$ of an individual measurement. For this reason, monitoring equipment should specify measurement performance in terms including both $u(\bar{x})$ and $u(x)$ to show the extent to which averaging is applied.

Table C.1 — t_e factors at 90 %, 95 % and 99 % confidence levels

Degrees of freedom	Confidence level %		
	90	95	99
1	6,31	12,71	63,66
2	2,92	4,30	9,92
3	2,35	3,18	5,84
4	2,13	2,78	4,60
5	2,02	2,57	4,03
10	1,81	2,23	3,17
15	1,75	2,13	2,95
20	1,72	2,09	2,85
25	1,71	2,06	2,79
30	1,70	2,04	2,75
40	1,68	2,02	2,70
60	1,67	2,00	2,66
100	1,66	1,98	2,63
Infinite	1,64	1,96	2,58

C.6 Evaluation of Type-B uncertainty

C.6.1 General

When there is no access to a continuous stream of measured data or if a large set of measurements is not available, then the Type-B method of estimation is used as follows:

- a) assign a probability distribution to the measurement process to represent the probability of the true value being represented by any single measured value;
- b) define upper and lower bounds of the measurement; and then
- c) determine a standard uncertainty from a standard deviation implied by the assigned probability distribution.

The Type-B methods allow estimates of upper and lower bounding values to be used to derive the equivalent standard deviation.

Four probability distributions are described in the GUM [6] and these are described in C.6.2 to C.6.5.

C.6.2 The triangular distribution

The triangular distribution is represented in Figure C.2.

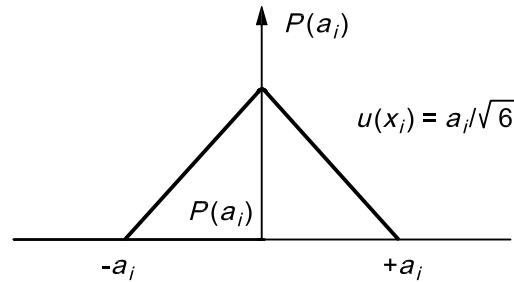

Figure C.2 — The triangular distribution

$$u(x_{\text{mean}}) = \frac{1}{\sqrt{6}} \left(\frac{x_{\text{max}} - x_{\text{min}}}{2} \right) \quad (\text{C.4})$$

This usually applies to manual measurements where the mean value is most likely to be closer to the true value than others between the discernible upper and lower limits of the measurement.

C.6.3 The rectangular distribution

The rectangular distribution is represented in Figure C.3.

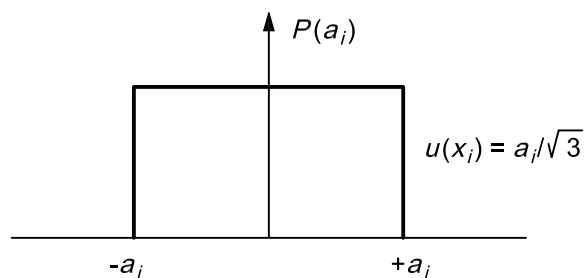

Figure C.3 — The rectangular distribution

$$u(x_{\text{mean}}) = \frac{1}{\sqrt{3}} \left(\frac{x_{\text{max}} - x_{\text{min}}}{2} \right) \quad (\text{C.5})$$

This probability distribution is usually applied to the resolution limit of the measurement instrumentation (i.e. the displayed resolution or the resolution of internal analogue/digital converters).

However, this is not the only source of uncertainty of measurement equipment. There may be uncertainty arising from the measurement algorithm used and/or from the calibration process.

If the equipment measures relative values, then there will also be uncertainty in the determination of its datum.

C.6.4 The normal probability distribution

The normal probability distribution is represented in Figure C.4.

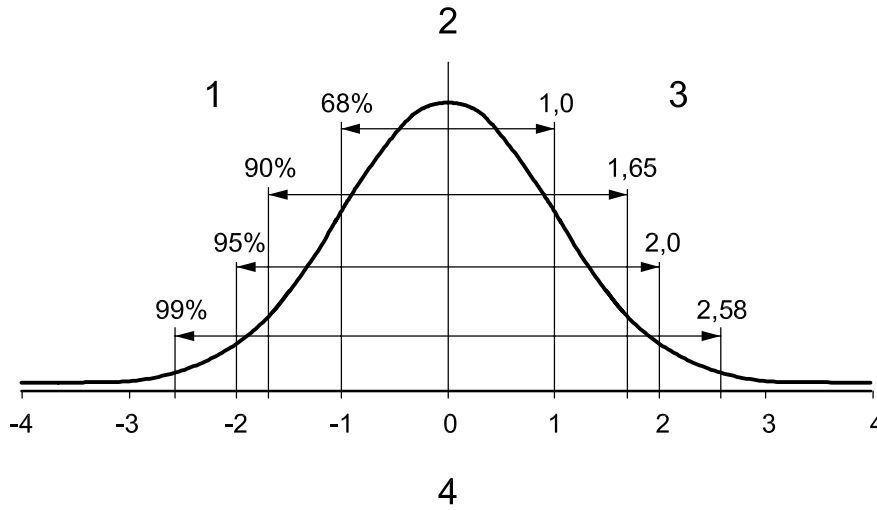

Key

- 1 percent of readings in bandwidth
- 2 probability
- 3 coverage factor
- 4 standard deviations

Figure C.4 — The normal probability distribution

$$u(x_{\text{mean}}) = \frac{u(\text{specified})}{k} \tag{C.6}$$

where k is the coverage factor applying to the specified uncertainty value.

These are uncertainty statements based on “off-line” statistical analysis, usually as part of a calibration process where they have been derived using a Type-A process.

When expressed as standard uncertainty, the uncertainty value is to be used directly with an equivalent coverage factor of $k = 1$.

C.6.5 The bimodal probability distribution

The bimodal probability distribution is represented in Figure C.5.

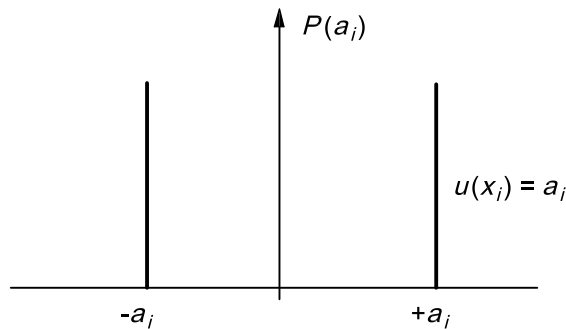

Figure C.5 — The bimodal probability distribution

$$u(x_{\text{mean}}) = \frac{(x_{\text{max}} - x_{\text{min}})}{2} \quad (\text{C.7})$$

Measurement equipment with hysteresis can only exhibit values at the upper and lower bounds of the measurement.

An example of this is the float mechanism where friction and surface tension combine to cause the float to move in finite steps.

C.7 Combined uncertainty value, u_c

For most measurement systems, a measurement result is derived from several variables. For example, flow measurement, Q , in a rectangular channel can be expressed as a function of independent variables:

$$Q = b \times h \times \bar{V} \quad (\text{C.8})$$

where

b is the channel width;

h is the depth of water in the channel;

\bar{V} is the mean velocity.

These three components are measured independently and combined to determine a value for Q .

Just as b , h and \bar{V} are combined to determine the value Q , so each component of uncertainty must be combined to determine a value for $u_c(Q)$. This is done by evaluating the sensitivity of Q to small change, Δ , in b , h or V . Thus:

$$\Delta Q = \frac{\partial Q}{\partial b} \Delta b + \frac{\partial Q}{\partial h} \Delta h + \frac{\partial Q}{\partial \bar{V}} \Delta \bar{V} \quad (\text{C.9})$$

where the partial differentials, $\frac{\partial Q}{\partial b}$, $\frac{\partial Q}{\partial h}$ and $\frac{\partial Q}{\partial \bar{V}}$, are sensitivity coefficients. For the equation $Q = b \times h \times \bar{V}$, this is equal to:

$$\frac{\Delta Q}{Q} = \frac{\Delta b}{b} + \frac{\Delta h}{h} + \frac{\Delta \bar{V}}{\bar{V}} \quad (\text{C.10})$$

In uncertainty analysis, the values, $\frac{\Delta Q}{Q}$, $\frac{\Delta b}{b}$, $\frac{\Delta \bar{V}}{\bar{V}}$ and $\frac{\Delta h}{h}$ correspond to dimensionless standard uncertainties. They are given the notation $u_c^*(Q)$, $u^*(b)$, $u^*(V)$ and $u^*(h)$.

Since the uncertainties of b , V and h are independent of each other, probability considerations require summation in quadrature.

$$u_c^*(Q) \cong \sqrt{u^*(\bar{V})^2 + u^*(b)^2 + u^*(h)^2} \quad (\text{C.11})$$

Annex D
(informative)

**Sample measurement performance for use
in hydrometric worked examples**

Table D.1 — Sample measurement performance for use in hydrometric worked examples

Measurement technologies	Comment	Symbol	Uncertainty options		Installed equipment to have corresponding values certified by the manufacturer									
			A	B	Nominal range of measurement			Corresponding standard uncertainty (68 % confidence limit)						
Velocity (continuous)					Minimum	25 %	50 %	75 %	Maximum	Minimum	25 %	50 %	75 %	Maximum
Point velocity	Propeller	$u(V)$	YES	Normal	0,005 m/s	1,250 m/s	2,500 m/s	3,750 m/s	5,000 m/s	0,000 5 m/s	0,010 m/s	0,022 m/s	0,030 m/s	0,040 m/s
	Electromagnetic	$u(V)$	YES	Normal	0,005 m/s	0,750 m/s	1,500 m/s	2,250 m/s	3,000 m/s	0,000 5 m/s	0,010 m/s	0,018 m/s	0,025 m/s	0,025 m/s
Path velocity	Time of flight sonar	$u(V)$	YES	Rectangular	0,030 m/s	0,250 m/s	0,500 m/s	0,750 m/s	1,000 m/s	0,003 m/s	0,005 m/s	0,007 m/s	0,007 m/s	0,010 m/s
	Gated Doppler sonar	$u(V)$	YES	Rectangular	0,030 m/s	0,250 m/s	0,500 m/s	0,750 m/s	1,000 m/s	0,003 m/s	0,005 m/s	0,007 m/s	0,007 m/s	0,010 m/s
	Sonar correlation	$u(V)$	YES	Rectangular	0,030 m/s	0,250 m/s	0,500 m/s	0,750 m/s	1,000 m/s	0,003 m/s	0,005 m/s	0,007 m/s	0,007 m/s	0,010 m/s
Section velocity	EM To be calibrated <i>in situ</i>	$u(V)$	—	Rectangular	0,030 m/s	0,250 m/s	0,500 m/s	0,750 m/s	1,000 m/s	0,003 m/s	0,005 m/s	0,007 m/s	0,007 m/s	0,010 m/s
Water level (continuous)														
Relative datum (to be applied to all methods)	Manual process	$u(E)$	—	Triangular	Not applicable	0,500 m	1,000 m	1,500 m	2,000 m	0,001 m	0,001 m	0,001 5 m	0,001 5 m	0,001 5 m
	Encoder/float system	$u(h_1)$	—	Bimodal	Extension 0,200 m	Extension 1,250 m	Extension 2,500 m	Extension 3,750 m	Extension 5,000 m	0,001 5 m	0,002 0 m	0,002 0 m	0,002 5 m	0,002 5 m
In-contact methods	Pressure transducer	$u(h_1)$	—	Rectangular	0,010 m	0,500 m	1,000 m	1,500 m	2,000 m	0,002 m	0,002 m	0,002 5 m	0,002 5 m	0,003 0 m
	Sonar	$u(h_1)$	YES	Rectangular	0,050 m	0,500 m	1,000 m	1,500 m	2,000 m	0,001 m	0,001 m	0,001 5 m	0,001 5 m	0,001 5 m
Non-contact methods	Pulse echo ultrasound	$u(R)$	YES	Rectangular	Range 0,300 m	Range 1,250 m	Range 2,500 m	Range 3,750 m	Range 5,000 m	0,002 m	0,004 m	0,010 m	0,025 m	0,060 m
	Pulse echo opto/radar	$u(R)$	—	Rectangular	Range 0,300 m	Range 1,250 m	Range 2,500 m	Range 3,750 m	Range 5,000 m	0,002 m	0,004 m	0,010 m	0,025 m	0,060 m
Cross-section profile (distance measurement)														
—	Natural channels	$u(B)$	—	Rectangular	0,500 m	5,000 m	10,000 m	15,000 m	20,000 m	0,002 m	0,020 m	0,060 m	0,100 m	0,200 m
—	Man-made channels	$u(B)$	—	Triangular	Not applicable	0,500 m	1,000 m	1,500 m	2,000 m	0,001 m	0,001 m	0,001 5 m	0,001 5 m	0,001 5 m

Bibliography

- [1] ISO 748, *Hydrometry — Measurement of liquid flow in open channels using current-meters or floats*
- [2] ISO 1100-1, *Measurement of liquid flow in open channels — Part 1: Establishment and operation of a gauging station*
- [3] ISO/TS 24154, *Hydrometry — Measuring river velocity and discharge with acoustic Doppler profilers*
- [4] ISO/TS 25377, *Hydrometric uncertainty guidance (HUG)*
- [5] ISO/IEC 17025, *General requirements for the competence of testing and calibration laboratories*
- [6] ISO/IEC Guide 98-3¹⁾, *Uncertainty of measurement — Part 3: Guide to the expression of uncertainty in measurement (GUM:1995)*

1) ISO/IEC Guide 98-3 will be published as a reissue of the GUM:1995.

Copyright International Organization for Standardization

