**Plastics collapsible containers for
human blood and blood components —**

**Part 1:
Conventional containers**

*Poches en plastique souple pour le sang et les composants du sang —
Partie 1: Poches conventionnelles*





COPYRIGHT PROTECTED DOCUMENT

© ISO 2013

All rights reserved. Unless otherwise specified, no part of this publication may be reproduced or utilized otherwise in any form or by any means, electronic or mechanical, including photocopying, or posting on the internet or an intranet, without prior written permission. Permission can be requested from either ISO at the address below or ISO's member body in the country of the requester.

ISO copyright office
Case postale 56 • CH-1211 Geneva 20
Tel. + 41 22 749 01 11
Fax + 41 22 749 09 47
E-mail copyright@iso.org
Web www.iso.org

Published in Switzerland

Contents

Page

Foreword	iv
Introduction	v
1 Scope	1
2 Normative references	1
3 Terms and definitions	1
4 Dimensions and designation	2
4.1 Dimensions.....	2
4.2 Designation example.....	2
5 Design	2
5.1 General.....	2
5.2 Air content.....	2
5.3 Emptying under pressure.....	2
5.4 Pilot samples.....	2
5.5 Rate of collection.....	3
5.6 Collection and transfer tube(s).....	5
5.7 Blood-taking needle.....	5
5.8 Outlet port(s).....	6
5.9 Suspension.....	6
6 Requirements	6
6.1 General.....	6
6.2 Physical requirements.....	7
6.3 Chemical requirements.....	8
6.4 Biological requirements.....	9
7 Packaging	10
8 Labelling	10
8.1 General.....	10
8.2 Label on plastics container.....	10
8.3 Label on over-package.....	11
8.4 Label on shipping box.....	11
8.5 Label requirements.....	11
9 Anticoagulant and/or preservative solution	12
Annex A (normative) Chemical tests	13
Annex B (normative) Physical tests	18
Annex C (normative) Biological tests	20
Bibliography	23

Foreword

ISO (the International Organization for Standardization) is a worldwide federation of national standards bodies (ISO member bodies). The work of preparing International Standards is normally carried out through ISO technical committees. Each member body interested in a subject for which a technical committee has been established has the right to be represented on that committee. International organizations, governmental and non-governmental, in liaison with ISO, also take part in the work. ISO collaborates closely with the International Electrotechnical Commission (IEC) on all matters of electrotechnical standardization.

International Standards are drafted in accordance with the rules given in the ISO/IEC Directives, Part 2.

The main task of technical committees is to prepare International Standards. Draft International Standards adopted by the technical committees are circulated to the member bodies for voting. Publication as an International Standard requires approval by at least 75 % of the member bodies casting a vote.

Attention is drawn to the possibility that some of the elements of this document may be the subject of patent rights. ISO shall not be held responsible for identifying any or all such patent rights.

ISO 3826-1 was prepared by Technical Committee ISO/TC 76, *Transfusion, infusion and injection, and blood processing equipment for medical and pharmaceutical use*.

This second edition cancels and replaces the first edition (ISO 3826-1:2003), of which it constitutes a minor revision with the following changes:

- [Figure 1](#) on the schematic representation of plastics containers has been updated;
- [Table 1](#) has been amended to include a plastics container with a nominal capacity of 600 ml;
- [subclause 5.6.5](#) on requirements for sterile connection transfer tubing has been added;
- [subclause 5.8.1](#) on the outlet port(s) has been amended by a specification for placement of the septum and by a Note 2;
- [subclauses 5.8.3](#) and [5.8.4](#) on further requirements for the outlet port(s) have been added;
- Clause B.5 on a test for sterile connection of tubing has been added;
- [Annex C](#) on biological tests has been completely revised and shortened in order to incorporate the linkage to the ISO 10993 series;
- the Bibliography has been updated;
- minor editorial changes have been made throughout the whole document.

ISO 3826 consists of the following parts, under the general title *Plastics collapsible containers for human blood and blood components*:

- *Part 1: Conventional containers*
- *Part 2: Graphical symbols for use on labels and instruction leaflets*
- *Part 3: Blood bag systems with integrated features*

The following parts are under preparation:

- *Part 4: Aphaeresis blood bag systems with integrated features*

Introduction

In some countries, national pharmacopoeias or other government regulations are legally binding and these requirements take precedence over this part of ISO 3826.

The manufacturers of the plastics container, or the suppliers, are expected to disclose in confidence to the national control authority, if requested by them, full details of the plastics material(s) and the components of the materials and their methods of manufacture, details of manufacture of the plastics containers, including the chemical names and quantities of any additives, whether incorporated by the manufacturer of the plastics containers or present in the raw material, as well as full details of any additives that have been used.

Universal leucocyte depletion is mandatory in various countries. This part of ISO 3826 is considered a basic document for other standards which include technical innovations.

The requirements in this part of ISO 3826 are intended to

- a) ensure that the quality of blood and blood components is maintained as high as necessary,
- b) make possible efficient and safe collection, identification, storage, separation, and transfusion of the contents, with special attention to reducing or minimizing the risks resulting from
 - contamination, in particular, microbiological contamination,
 - air embolism,
 - errors in identification of plastics containers and any representative samples of contents,
 - interaction between the plastics container and its contents,
- c) ensure functional compatibility when used in combination with transfusion sets as specified in ISO 1135-4,
- d) provide a package with appropriate resistance to breakage and deterioration.

Plastics collapsible containers for human blood and blood components —

Part 1: Conventional containers

1 Scope

This part of ISO 3826 specifies requirements, including performance requirements, for plastics collapsible, non-vented, sterile containers complete with collecting tube outlet port(s), integral needle, and with optional transfer tube(s), for the collection, storage, processing, transport, separation, and administration of blood and blood components. The plastics containers may contain anticoagulant and/or preservative solutions, depending on the application envisaged.

This part of ISO 3826 is also applicable to multiple units of plastics containers, e.g. to double, triple, quadruple, or multiple units.

Unless otherwise specified, all tests specified in this part of ISO 3826 apply to the plastics container as prepared ready for use.

This part of ISO 3826 is not applicable to plastics containers with an integrated filter.

2 Normative references

The following documents, in whole or in part, are normatively referenced in this document and are indispensable for its application. For dated references, only the edition cited applies. For undated references, the latest edition of the referenced document (including any amendments) applies.

ISO 1135-4:2012, *Transfusion equipment for medical use — Part 4: Transfusion sets for single use*

ISO 3696:1987, *Water for analytical laboratory use — Specification and test methods*

ISO 10993-1, *Biological evaluation of medical devices — Part 1: Evaluation and testing within a risk management process*

ISO 10993-4, *Biological evaluation of medical devices — Part 4: Selection of tests for interactions with blood*

ISO 10993-5, *Biological evaluation of medical devices — Part 5: Tests for in vitro cytotoxicity*

ISO 10993-10, *Biological evaluation of medical devices — Part 10: Tests for irritation and skin sensitization*

ISO 10993-11, *Biological evaluation of medical devices — Part 11: Tests for systemic toxicity*

ISO 10993-12, *Biological evaluation of medical devices — Part 12: Sample preparation and reference materials*

3 Terms and definitions

For the purposes of this document, the following terms and definitions apply.

3.1

plastics container

bag, of plastics material, complete with collecting tube and needle, port(s), anticoagulant, and/or preservative solutions, and transfer tube(s) and associated container(s), where applicable

3.2 shelf life

period between the date of sterilization and the expiry date after which the plastics container(s) should not be used for the collection of blood

4 Dimensions and designation

4.1 Dimensions

[Figure 1](#) illustrates the components of a plastics container. The values of the dimensions shown in [Figure 1](#) are binding and form part of the requirements of this part of ISO 3826; the dimensions given in [Table 1](#) are for guidance only.

4.2 Designation example

Plastics containers are designated using the descriptor words “Plastics container” followed by the number of this part of ISO 3826, followed by the nominal capacity of the container, in millilitres. For example, the designation of a plastics container with a nominal capacity of 500 ml in accordance with this part of ISO 3826 is

Plastics container ISO 3826-1:2013, 500

5 Design

5.1 General

The design and manufacture of the plastics container shall provide for the safe and convenient collection, storage, processing, transport, separation, and administration of whole blood and blood components. The plastics container shall permit the collection of blood and the preparation of plasma or centrifuged or resuspended cellular components with a minimal hazard of contamination by microorganisms. The plastics container shall be functionally compatible with the transfusion set specified in ISO 1135-4. Its design shall also ensure that it can be used in a centrifuge cup.

5.2 Air content

5.2.1 The total volume of air contained in the plastics container system divided by the number of containers shall not exceed 15 ml.

NOTE Typical plastics container systems are described in ISO 3826-3.

5.2.2 When used in accordance with the manufacturer’s instructions, the plastics container shall be capable of being filled with blood without air being introduced.

5.3 Emptying under pressure

The plastics container, when filled with a volume of water at a temperature of (23 ± 5) °C equal to its nominal capacity and connected to a transfusion set as specified in ISO 1135-4 inserted in an outlet port (see [5.8](#)), shall empty without leakage within 2 min when gradually squeezed between two plates to an internal pressure of 50 kPa above atmospheric pressure.

5.4 Pilot samples

The plastics container shall be designed so that pilot samples of unmistakable identity can be collected for the performance of compatibility tests without the closed system of the plastics container being penetrated. This may be accomplished, e.g. by using an unmistakable numbering system on the tubing.

5.5 Rate of collection

The plastics container shall be designed so that it is capable of being filled to its nominal capacity in less than 8 min when tested in accordance with B.2.

Dimensions in millimetres

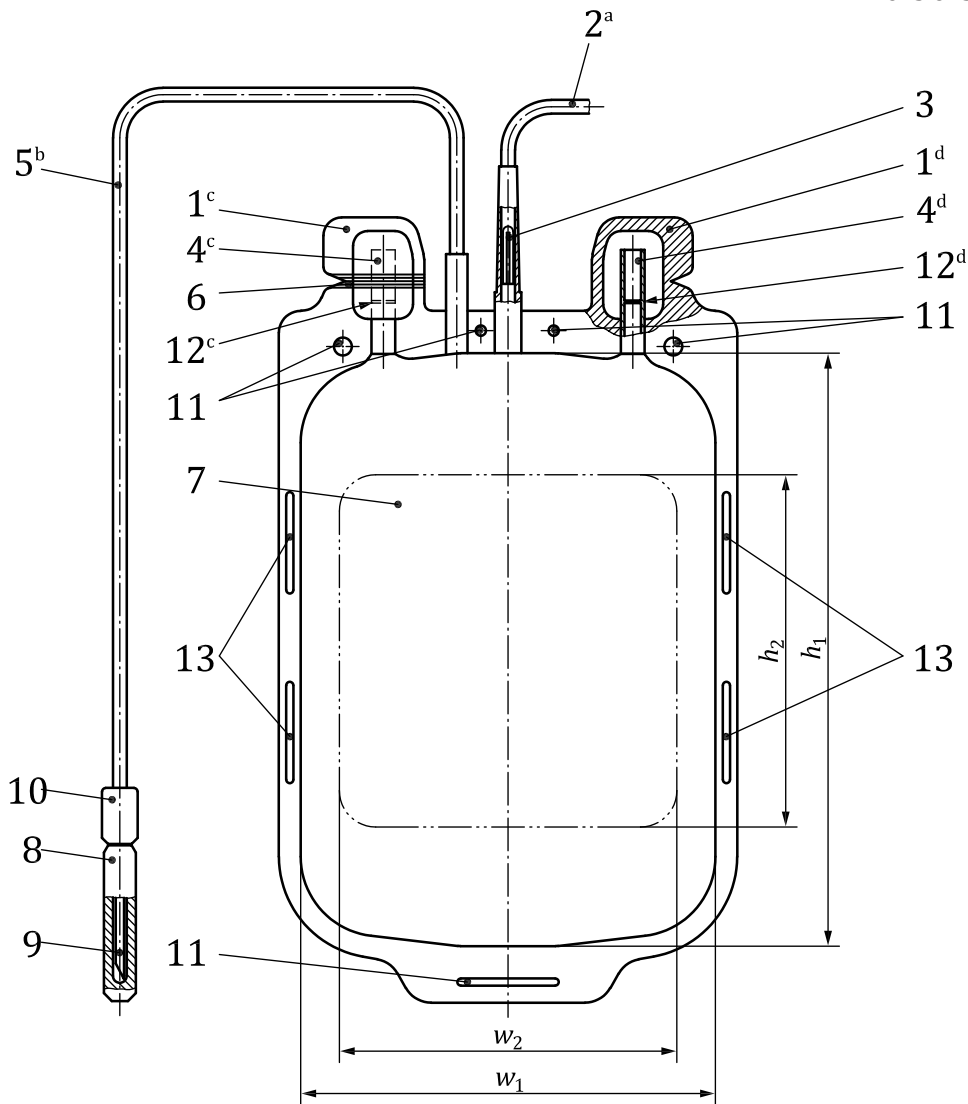

Key

- | | | | |
|---|-----------------------------|----|---------------------------------------|
| 1 | tamper evident protector(s) | 8 | tamper evident protective cap |
| 2 | transfer tube | 9 | blood-taking needle |
| 3 | means of closure (optional) | 10 | needle hub |
| 4 | outlet port(s) | 11 | eyelets |
| 5 | collection tube | 12 | puncturable non-resealable closure(s) |
| 6 | tear line of protector | 13 | side slits |
| 7 | label area | | |
- a Length ≥ 200 mm, internal diameter $\geq 2,7$ mm, wall thickness $\geq 0,5$ mm.
 b Length ≥ 800 mm if used for gravitational collection, internal diameter $\geq 2,7$ mm, wall thickness $\geq 0,5$ mm.
 c External view..
 d Cross-sectional view.

NOTE See [Table 1](#) for explanation of dimensions.

Figure 1 — Schematic representation of plastics container

Table 1 — Dimensions for plastics containers, label areas, and nominal capacity

Dimensions in millimetres

Nominal capacity ml	Inside width w_1	Inside height h_1	Size of label area	
			$w_2 \pm 5$	$h_2 \pm 5$
100	75	120	60	85
250	120	130	90	85
400	120	170	105	105
500/600	120	185	105	105

5.6 Collection and transfer tube(s)

5.6.1 The plastics container may be provided with one or more collection or transfer tube(s) to allow the collection and separation of blood and blood components.

If a transfer tube is present, and if necessary to avoid unexpected flow between containers, it shall be fitted with a device which first acts as a seal and then, when broken, permits the free flow of blood components in either direction.

5.6.2 The tubes shall be such that they can be sealed hermetically and do not collapse under normal use.

5.6.3 The plastics container, filled with water to its nominal capacity and sealed, and the tubes connected to the plastics container shall form a hermetic seal and a tight leakproof joint (see Note in [6.2.7](#)) which will withstand, without leakage occurring, a tensile force of 20 N applied to the tubing for 15 s. The tensile force shall be applied at right angles to the edge of the joint and along the longitudinal axis of the plane of the plastics container at a temperature of $(23 \pm 5) ^\circ\text{C}$.

There shall be no leakage at the junctions and the plastics container shall also conform to the requirements specified in [6.2.7](#).

5.6.4 Under visual inspection, the tubing shall not display cracks, blisters, kinks, or other defects.

5.6.5 Requirements for sterile connection of transfer tubing: Tubing design shall allow the efficient transfer of blood and blood components between packs. Design should also allow the joining of tubes supplied by a single manufacturer or from different manufacturers using a sterile tube welding device. Typically, this is to enable the connection of separate satellite packs when preparing blood components by a 'secondary process'. Sterile tube welding devices join the two opposing ends of the tube while maintaining a sterile fluid pathway.

Manufacturers of sterile tube welding devices typically specify acceptable tube dimensions (external and/or internal diameter and wall thickness) for use on their equipment. Blood bag manufacturers must specify in their product documentation the material, internal and external diameters, and wall thickness of all their tubing to allow blood transfusion services to assess the suitability for tube welding.

When a blood transfusion service wishes to weld tubing of different specifications, they should carry out a validation before proceeding. A protocol is provided (see Clause B.5) as a minimum standard for such validations (see also Reference[5]).

5.7 Blood-taking needle

The blood-taking needle shall be integral with the collection tube and covered by a protective cap. The protective cap shall prevent leakage of anticoagulant and/or preservative solution from the plastics container during storage, shall maintain the sterility of the fluid path, and shall be readily removable. The protective cap shall be tamper-evident and manufactured so that either it is impossible to replace or any attempt at manipulating it is blatantly obvious.

The internal and external surfaces of the blood-taking needle shall be clean and smooth. The bevel of the needle shall be sharp and free from ridges, burrs, and barbs.

The joint between the blood-taking needle and the needle hub shall withstand a static tensile (pull) force and compressive (push) force of 20 N for 15 s along the longitudinal axis.

The blood-taking needle may contain a needle-stick protection device in accordance with ISO 3826-3.

5.8 Outlet port(s)

5.8.1 The plastics container shall be provided with one or more outlet ports for the administration of blood and blood components through a transfusion set. The port(s), which shall have a puncturable non-resealable closure port septum placed (14 ± 2) mm from the top of the port, shall allow connection of a transfusion set having a closure-piercing device in accordance with ISO 1135-4 without leakage on insertion or during conditions of use, including emptying under pressure (see [5.3](#)). Before the closure is pierced by the point of the closure-piercing device, the outlet port(s) shall be tightly occluded by the closure-piercing device. When used in accordance with manufacturer's instructions, the piercing device shall not damage the plastic film of the plastics container on insertion.

NOTE 1 For the dimensions of the closure-piercing device, see ISO 1135-4.

NOTE 2 When designing the outlet port to ensure good compatibility with closure-piercing devices, manufacturers should avoid the use of tubing that is highly inflexible. Thin-walled tubing (<1 mm) should also be avoided as this tends to twist and collapse on insertion.

5.8.2 Each outlet port shall be fitted with a hermetically sealed, tamper-evident protector to maintain the sterility of the internal surface.

5.8.3 When a closure-piercing device conforming to ISO 1135-4 is inserted into the blood bag port, this shall resist a pull force of 15 N for 15 s.

5.8.4 When tested in accordance with [5.3](#), the connection between the closure-piercing device and the blood bag port shall show no evidence of leakage.

5.9 Suspension

The plastics container shall have adequate means of suspension or positioning (see, for example, eyelets in [Figure 1](#)) which do not interfere with the use of the plastics container during collection, storage, processing, transport, and administration. The means of suspending or positioning the container shall be capable of withstanding a tensile force of 20 N applied along the longitudinal axis of the outlet port(s) for 60 min at a temperature of (23 ± 5) °C without breaking.

6 Requirements

6.1 General

The plastics container shall be transparent, virtually colourless (see [6.2.4](#)), flexible, sterile, non-pyrogenic, biologically safe (see [6.4](#)), and non-frangible under conditions of use (see [6.2.5](#)). It shall be compatible with the contents under normal conditions of storage. The plastics container shall meet the requirements for terminal sterilization and shall not become tacky during sterilization and storage for its shelf life at temperatures not exceeding 40 °C.

The plastics container shall be stable biologically, chemically, and physically with respect to its contents during its shelf life and shall not permit penetration of microorganisms. Any substances leached from the plastics container by the contained anticoagulant and/or preservative solution, blood, and blood components by either chemical interaction or physical dissolution, shall be within the limits specified.

In many countries, national pharmacopoeias specify formulations of different plastics materials, such as flexible PVC with different plasticizers and other plastics materials, while government regulations or standards may detail suitable tests for assessing chemical or physical interactions.

6.2 Physical requirements

6.2.1 Conditions of manufacture

All processes involved in the manufacture, assembly, and storage of the plastics container shall be carried out under clean and hygienic conditions in compliance with the appropriate national regulations, in accordance with relevant legislation and international agreements, such as current GMP requirements.^[3] Every practicable precaution shall be taken at all stages to reduce the risk of adventitious contamination by microorganisms or foreign matter.

6.2.2 Sterilization

6.2.2.1 The plastics container shall have been sterilized by steam sterilization or any other validated method.

6.2.2.2 The method of sterilization used shall not adversely affect the materials or contents, nor cause any loosening of joints and deterioration of welds in the plastics material nor any major alteration in the shape of the plastics container.

6.2.2.3 The manufacturer shall be able to produce evidence acceptable to the national control authority of the effectiveness of the sterilization process actually used. If required by the national control authority, positive controls to check the effectiveness of sterilization shall be included in each sterilization lot.

6.2.3 Transparency

When tested as specified in B.1, the opalescence of the suspension shall be perceptible when viewed through the plastics container as compared with a similar plastics container filled with water.

6.2.4 Coloration

The material of the sterilized plastics container shall not be coloured to such an extent that assessment of the colour of the blood is adversely affected.

6.2.5 Thermal stability

This requirement refers primarily to plasma-freezing bags.

The plastics container, filled to half of its nominal capacity with water as specified in ISO 3696, shall withstand a slow freezing to and storage at -80 °C for 24 h, subsequent immersion in water at $(37 \pm 2)\text{ °C}$ for 60 min, and returning to room temperature. The plastics container shall meet the requirements of [5.6.3](#), [5.9](#), [6.2.7](#), and [6.2.8](#). Plastics containers intended to be shock-frozen (blast-frozen) or irradiated shall be validated for those specific applications.

If a refrigerant solution is used, the plastics container may be enclosed in a protective bag to avoid direct contact between the refrigerant solution and the plastics container.

6.2.6 Water vapour transmission

The plastics container, without an over-package, shall be filled to its nominal capacity with water as specified in ISO 3696, sealed, and labelled ready for use. The plastics container shall then be capable of

being stored for 42 days at a temperature of $(4 \pm 2) ^\circ\text{C}$ without loss of a mass fraction of more than 2 % of water from the solution.

NOTE The storage of certain blood components, such as platelet concentrates, may require specific gas exchange rates for oxygen and carbon dioxide.

6.2.7 Resistance to leakage

When filled to nominal capacity with water as specified in ISO 3696 and sealed, the plastics container shall not develop leaks under conditions of centrifugation at 5 000 *g* at 37 °C for 10 min. The plastics container is then squeezed between two plates to an internal pressure equivalent to 50 kPa above atmospheric pressure at $(23 \pm 5)^\circ\text{C}$ for 10 min. No leakage is allowed on visual inspection.

For containers of flexible poly(vinyl chloride) (PVC), both tests should be repeated at 4 °C. Plastics containers that are normally centrifuged without solution shall be subjected to the same centrifugation conditions as noted above without solution. Following this, the plastics container shall withstand an internal pressure equivalent to 50 kPa above atmospheric pressure after filling to nominal capacity.

NOTE When the plastics container is filled with anticoagulant solution, such as an ACD solution or other solutions with similar pH, leakage can be detected by pressing the plastics container against sheets of blue litmus paper and observing the development of pink spots on the paper. For solutions of other pH, the same method with an appropriate indicator can be used. Alternative methods affording at least the same degree of sensitivity may be used.

6.2.8 Particulate contamination

Plastics containers shall be manufactured so that contamination with particles is minimized.

When tested as described in B.4, the fluid path within the plastics container should be free from visible particles.

NOTE For the time being, limits and test procedures given in pharmacopoeias, for example, those specified in the European Pharmacopoeia for parenteral solutions, might be used.

6.3 Chemical requirements

6.3.1 Requirements for the raw container or sheeting

The sheeting shall fulfil the requirements given in the relevant pharmacopoeias. Alternatively, it may be tested as described in [Table 2](#).

Table 2 — Ignition residues for polyolefins and PVC

Test	Plastics material	Maximum permissible residue	Test as specified in
Residue on ignition	Polyolefins	0,5 mg/g	A.2
	PVC containing plasticizers	1 mg/g	

6.3.2 Requirements for the test fluid

The limits specified in [Table 3](#) shall not be exceeded when the appropriate tests are carried out on the extract obtained in accordance with [Annex A](#).

Table 3 — Chemical limits on extracts from plastics container

Characteristics		Maximum permissible value	Test method in
Oxidizable constituents		1,5 ml	A.4.1
Ammonia		0,8 mg/l	A.4.2
Chloride ions (Cl ⁻)		4 mg/l	A.4.3
Metals:	Ba, Cr, Cu, Pb Sn, Cd Al	For each metal: 1 mg/l For each metal: 0,1 mg/l 0,05 mg/l	A.4.4.1
Heavy metals		2 mg/l	A.4.4.2
Acidity or alkalinity		0,4 ml sodium hydroxide solution, $c(\text{NaOH}) = 0,01 \text{ mol/l}$ or 0,8 ml hydrochloric acid, $c(\text{HCl}) = 0,01 \text{ mol/l}$	A.4.5
Residue on evaporation		5 mg or 50 mg/l	A.4.6
Opalescence		Slightly opalescent, but not more pronounced than that of reference suspension	A.4.7
Coloration		No coloration	A.4.8
UV absorbance		In the range of 230 nm to 360 nm 0,25 for plastics containers with a nominal capacity $\leq 100 \text{ ml}$ and 0,2 for plastics containers with a nominal capacity $> 100 \text{ ml}$	A.4.9
Extractable plasticizer, e.g. di(2-ethylhexyl) phthalate (DEHP) ^a		15 mg/100 ml	A.4.10
^a Only for flexible PVC containing DEHP.			

Materials used in the manufacture of plastics containers for human blood and blood components shall be carefully chosen so as to minimize the risks arising from leaching of chemical constituents into the product. Particular attention shall be given to the toxicity of the materials used and the biological compatibility of the plastics container with the product.

NOTE National pharmacopoeias have monographs on plastic materials which specify the composition and limit of different constituents, as well as limits of metals such as Ba, Pb, Cd, Sn, Cr, and e.g. vinyl chloride monomers, where applicable.

6.4 Biological requirements

6.4.1 General

The plastics container shall not adversely affect the therapeutic effectiveness of blood and blood components and not release substances which may exhibit undue toxic, cytotoxic, bacteriostatic, bactericidal, pyrogenic, or haemolytic reactions.

Typical biological safety tests are given in the ISO 10993 series.

6.4.2 Impermeability for microorganisms

The plastics container shall be impermeable to microorganisms when tested as specified in C.3.

6.4.3 Compatibility

When tested as specified in C.4, C.5, and C.6, the plastics containers shall not release to the anticoagulant/preservative solution and/or blood or blood components any substances in such quantities that they have a pyrogenic, toxic, or haemolytic effect.

7 Packaging

7.1 The requirements in 7.2 to 7.6 are related to the plastics container in its sealed over-package.

7.2 The shelf life (see 3.2) of the plastics container shall be established by the manufacturer on the basis of stability data. When containing anticoagulant and/or preservative solution, the container shall have a shelf life not greater than the time during which the water loss from the container equals a mass fraction of 5 % at defined storage conditions of temperature and humidity.

7.3 The materials of the over-package or any treatment to its interior surface should neither interact with the plastic of the container or its contents nor support mould growth. If chemical fungicides are used, evidence shall be provided to show there has been no harmful penetration of, or effect on, the plastics container and its contents.

7.4 The over-package shall be sealed in such a manner as to be tamper-evident and to prevent opening or reclosing without displaying signs that the seal has been destroyed.

7.5 The over-package shall be strong enough to resist damage under conditions of normal handling and use.

7.6 The plastics container and components shall be arranged in the over-package in a manner which will minimize the collecting tube and transfer tube(s) from kinking and acquiring a permanent set.

8 Labelling

8.1 General

The labelling of a plastics container shall conform to applicable national regulations. In absence of national regulations, the labelling shall include the requirements as specified in 8.2 to 8.5. If graphical symbols are used, then refer to ISO 3826-2 and ISO 15223-1.

NOTE The European Medical Device Directive (93/42/EEC as amended by 2007/47/EC) requires labelling of medical devices containing phthalates (see EN 15986).

8.2 Label on plastics container

The label shall, if possible and where applicable, contain the information specified in a) to i). However, if the available label space is too small for this purpose, it is permissible to give the information of items f), g) and h) in the instructions for use rather than on the label:

- a) manufacturer's name and address and/or the name and address of the supplier responsible;
- b) description of the contents and intended use;
- c) nature, formulation and volume (in millilitres) or mass (in grams) of anticoagulant and/or preservative solution and any other material introduced, and the volume (in millilitres), or mass (in grams) of blood and blood components to be collected;
- d) a statement defining the conditions of sterility and non-pyrogenicity;
- e) lot designation;
- f) an instruction that the container is for single use only;
- g) an instruction indicating not to use the plastics container if there is any visible sign of deterioration;
- h) an instruction indicating not to vent;

- i) a reference to the instructions for use of the plastics container.

If appropriate, the label can also contain information concerning the date after which the container should not be used to collect blood and concerning the manufacturer's product code.

8.3 Label on over-package

The over-package label shall contain the following information:

- a) manufacturer's name and address and/or the name and address of the supplier responsible;
- b) description of the contents;
- c) lot designation;
- d) expiry date;
- e) instruction indicating that the plastics container shall not be used more than $n^1)$ days after removal from the over-package.

If a transparent over-package is used, all the information required under [8.2](#) and [8.3](#) should appear on the label of the plastics container.

8.4 Label on shipping box

The label, which should be visible when palletted, shall contain the following information:

- a) manufacturer's name and address and/or the name and address of the supplier responsible;
- b) description of the contents;
- c) lot designation;
- d) expiry date;
- e) if the transit container functions as an over-package, an instruction indicating that the plastics container shall not be used more than $n^2)$ days after removal from the over-package;
- f) storage conditions.

8.5 Label requirements

The label on the plastics container shall be such that

- a) an appropriate label area is reserved for information related to the plastics container manufacturer and user;

NOTE Usually, 30 % of the label area is intended for entries of the manufacturer and 70 % of the label area is intended for entries or over-labelling of those who fill the plastics container with blood.

- b) by leaving a portion of the plastics container visible and free of markings, the contents can be adequately inspected visually;
- c) there is no diffusion of the print from the label into the material of the plastics container;
- d) the printing on the label remains legible at the time of use;
- e) any adhesive used on the label shall not support mould growth and evidence shall be provided to show there has been no harmful effect on the plastics container and its contents;

1) If there are no applicable national regulations, n is determined by the manufacturer.

2) If there are no applicable national regulations, n is determined by the manufacturer.

- f) any attempt to peel off the label shall result in the label being destroyed;
- g) when tested in accordance with B.3, the label(s) shall not separate from the plastics containers after removal from water. Printing on the label or on the plastics container shall remain legible.

9 Anticoagulant and/or preservative solution

The quality of the anticoagulant and/or preservative solution, if any, shall satisfy the requirements of the national pharmacopoeia and national regulations.

Annex A (normative)

Chemical tests

A.1 General

Take materials for testing from the blood and blood derivatives contact materials of the finished, sterilized, and, if necessary, emptied plastics containers, i.e. in the state in which they would be used for transfusion, collection, separation, and administration procedures, including the plastic sheet used for the collecting bag and the plastic tubings used for the collection tube, transfer tube, and any parts that come into contact with blood and blood components.

A.2 Determination of residue on ignition

Weigh 1,00 g to 2,00 g of the material (in small pieces) into a suitable crucible that has been previously ignited, cooled, and weighed. Heat to 100 °C to 105 °C for 1 h. Then ignite to (550 ± 25) °C. Allow to cool in a desiccator and weigh. Repeat ignition until constant mass is attained. Calculate mass of residue on ignition per gram of starting material.

Equivalent methods as described in pharmacopoeias may be used.

A.3 Preparation of the test fluid

Fill the empty container twice to the nominal capacity with water for injection, shake for approximately 1 min, and then empty. After the rinse water has drained off, fill the empty container to the nominal volume with water for injection. Then compress the container so that the remaining air escapes from the container, and subsequently close it. Extract the container for at least 30 min in pressurized, saturated steam at (121 ± 2) °C. Use 250 ml water for injection as a comparative fluid (blank sample). Heating and cooling times are not included in the 30 min cycle time requirement.

If appropriate, the extraction may be performed on pieces of sheeting or raw container. Use pieces with a total surface area of 1500 cm² which includes both sides of the plastic sheet. Wash this material twice with 100 ml water for injection and discard the water after use. Drain the pieces, cover them with 250 ml water for injection, and extract for 30 min in pressurized, saturated steam at (121 ± 2) °C. As a comparison fluid (blank sample), treat water for injection in the same manner.

Test on pieces of sheeting are only possible if the plastics material is homogeneous. Laminated sheeting must be transformed into an equivalent container first to selectively test the inner surface.

If the container is not intended for sterilization at temperatures of at least 121 °C, then the extraction may alternatively be performed at (100 ± 2) °C for a duration of 2 h or at (70 ± 2) °C for a duration of (24 ± 2) h, in which case the selected temperature should not be lower than that at which the container is used.

In the event that the solution resulting from extraction of a single container or single sample of sheeting has insufficient volume to allow for all of the required testing, the solutions from two or more extractions may be combined to produce a composite test solution. If alternative sterilization methods other than thermal sterilization are to be applied to the container, e.g. γ -irradiation, ethylene oxide, or e-beam, use sterilized containers for preparation of the test fluid.

A.4 Tests

A.4.1 Determination of oxidizable constituents

Boil for 3 min 20,0 ml of the test fluid with 20,0 ml potassium permanganate solution [$c(\text{KMnO}_4) = 0,002 \text{ mol/l}$] and 1,0 ml sulfuric acid [$c(\text{H}_2\text{SO}_4) = 1 \text{ mol/l}$]. Add 1,0 g of potassium iodide and titrate the solution with sodium thiosulfate solution [$c(\text{Na}_2\text{S}_2\text{O}_3) = 0,01 \text{ mol/l}$] until light brown. Then add five drops of starch solution and titrate until colourless.

Calculate the consumption of potassium permanganate solution [$c(\text{KMnO}_4) = 0,01 \text{ mol/l}$] for the test fluid and water serving as comparison fluid. The difference between the two values shall not be greater than 1,5 ml.

A.4.2 Determination of ammonia

Make alkaline 10 ml of the test fluid by adding 2 ml of caustic soda [$c(\text{NaOH}) = 1 \text{ mol/l}$], dilute with distilled water to 15 ml, and then add 0,3 ml Nessler's reagent³⁾.

Prepare the comparison solution simultaneously by making alkaline 8 ml of ammonium standard solution [$\rho(\text{NH}_4^+) = 1 \text{ mg/l}$] by adding 2 ml caustic soda [$c(\text{NaOH}) = 1 \text{ mol/l}$], diluting with distilled water to 15 ml, and then adding 0,3 ml Nessler's reagent.

After 30 s, examine the solution, which shall not be more strongly yellow-coloured than the comparison solution.

A.4.3 Determination of chloride ions

Add 0,3 ml of silver nitrate solution [$c(\text{AgNO}_3) = 0,1 \text{ mol/l}$] to 0,15 ml of diluted nitric acid. Add the resultant solution to 15 ml of the extract.

Prepare a reference solution in the same way using 12 ml of chloride standard solution (5 mg Cl^- per litre) and 3 ml of water.

Shake the mixtures. After 2 min, the solution prepared by using the extract shall not be more turbid than the reference solution. Avoid exposure of the solution to direct daylight.

A.4.4 Determination of metals

A.4.4.1 Heavy metals related to Pb^{2+}

The metals Ba, Cd, Cr, Cu, Pb, Sn, and Al are determined by atomic spectrometric analysis. The detection limit using AAS (Atomic Absorption Spectrometry) can be raised by concentrating the test fluid by evaporation in accordance with A.3, in which case 2,5 ml hydrochloric acid solution [$\rho(\text{HCl}) = 10 \text{ g/l}$] is added to 250 ml test fluid.

A.4.4.2 Alternative methods for testing for heavy metals

Chemical determination of the total of heavy metals can be used instead of the atomic spectrometric determination of metals in the test fluid according to A.3.

1,2 ml thioacetamide reagent is added to 12 ml of the test fluid and 2 ml ammonium acetate buffer solution ($\text{pH} = 3,5$) and immediately mixed.

Prepare the comparison solution in the same manner, using 10 ml lead solution [$\rho(\text{Pb}^{2+}) = 2 \text{ mg/l}$] and adding 2 ml of the test fluid. After 2 min, examine the solution; it shall not be a deeper shade of brown than the comparison solution.

3) See e.g. European Pharmacopoeia.

A.4.5 Determination of acidity or alkalinity

After the addition of two drops of phenolphthalein solution, 10 ml of the test fluid shall not be coloured red. However, on the addition of less than 0,4 ml caustic soda [$c(\text{NaOH}) = 0,01 \text{ mol/l}$], red coloration shall occur. After the addition of 0,8 ml hydrochloric acid [$c(\text{HCl}) = 0,01 \text{ mol/l}$], this coloration shall disappear again. On the addition of five drops methyl red solution, the solution shall have an orange-red coloration.

A.4.6 Determination of the evaporation residue

Evaporate 100 ml of the test fluid on a water bath and dry at 105 °C to constant mass.

A.4.7 Determination of turbidity and degree of opalescence

A.4.7.1 General

Using identical test tubes of colourless, transparent, neutral glass with a flat base and an internal diameter of 15 mm to 25 mm, compare the liquid to be examined with a reference suspension freshly prepared as described below, the depth of the layer being 40 mm. Compare the solutions in diffused daylight 5 min after preparation of the reference suspension, viewing them vertically against a black background. The diffusion of light shall be such that reference suspension 1 can readily be distinguished from water and that reference suspension 2 can readily be distinguished from reference suspension 1.

A.4.7.2 Reagents

A.4.7.2.1 Hydrazine sulfate solution

Dissolve 1 g of hydrazine sulfate in water and dilute to 100 ml. Allow to stand for 4 h to 6 h.

A.4.7.2.2 Hexamethylenetetramine solution

Dissolve 2,5 g of hexamethylenetetramine in 25 ml of water in a 100 ml glass-stoppered flask.

A.4.7.2.3 Primary opalescent suspension

Add to the solution of hexamethylenetetramine (A.4.7.2.2) 25 ml of the hydrazine sulfate solution (A.4.7.2.1). Mix and allow to stand for 24 h.

This suspension is stable for 2 months, provided that it is stored in a glass container free from surface defects. The suspension shall not adhere to the glass and shall be well mixed before use.

A.4.7.2.4 Standard of opalescence

Dilute 15 ml of the primary opalescent suspension (A.4.7.2.3) to 1 000 ml with water.

This suspension shall be freshly prepared and may be stored for at most 24 h.

A.4.7.2.5 Reference suspensions

Prepare the reference suspensions in accordance with [Table A.1](#). Mix and shake before use.

Table A.1 — Reference suspensions

Volumes in millilitres

Reference suspension	1	2	3	4
Standard of opalescence, volume	5	10	30	50
Water, volume	95	90	70	50

A.4.7.3 Expression of results

A.4.7.3.1 A liquid is deemed to be *clear* if its clarity is the same as that of water or of the solvent used, when examined under the conditions described above, or if its opalescence is not more pronounced than that of reference suspension 1.

A.4.7.3.2 A liquid is deemed to be *slightly opalescent* if its opalescence is more pronounced than as described in A.4.7.3.1, but not more pronounced than that of reference suspension 2.

A.4.7.3.3 A liquid is deemed to be *opalescent* if its opalescence is more pronounced than as described in A.4.7.3.2, but not more pronounced than that of reference suspension 3.

A.4.7.3.4 A liquid is *highly opalescent* if its opalescence is more pronounced than as described in A.4.7.3.3, but not more pronounced than that of reference suspension 4.

A.4.8 Determination of degree of coloration

A.4.8.1 General

The examination of the degree of coloration of liquids in the range brown-yellow-red shall be carried out by one of the two methods specified in A.4.8.2 and A.4.8.3.

A.4.8.2 Method 1

Using matched tubes of colourless, transparent, neutral glass having an internal diameter of 12 mm, compare 2 ml of the liquid to be examined with 2 ml of water. Compare the colours in diffused daylight, viewing them horizontally against a white background.

A.4.8.3 Method 2

Using matched tubes of colourless, transparent, neutral glass having an internal diameter of 16 mm, compare 10 ml of the liquid to be examined with 10 ml of water. Examine the column of liquid down the vertical axis of the tube in diffused daylight against a white background.

A.4.8.4 Expression of results

A liquid is deemed to be colourless if it has the appearance of water when examined under the conditions as specified for method 1 or 2.

A.4.9 Determination of the UV absorption

Determine the UV absorbance of the extract in a cuvette with an internal light path of 1 cm against the blank. The absorbance is determined in the range from 230 nm to 360 nm.

A.4.10 Determination of plasticizer as extractable di(2-ethylhexyl) phthalate (DEHP)

NOTE This determination applies only to flexible PVC containing DEHP.

A.4.10.1 Reagents

A.4.10.1.1 Ethanol, volume fraction φ in the range from 95,1 % to 96,6 %, density ρ in the range from 0,805 0 g/ml to 0,812 3 g/ml.

A.4.10.1.2 Extraction solvent, ethanol:water mixture of density ρ ranging from 0,937 3 g/ml to 0,937 8 g/ml, as determined with a pycnometer.

A.4.10.1.3 Di(2-ethylhexyl)phthalate ($C_{24}H_{38}O_4$), a colourless, oily liquid insoluble in water, soluble in organic solvents; ρ in the range from 0,982 g/ml to 0,986 g/ml, refractive index at 20 °C n_D^{20} in the range from 1,486 to 1,487.

A.4.10.2 Preparation of standard solutions

A.4.10.2.1 Solution 1

Dissolve 1 g of DEHP (A.4.10.1.3) in ethanol (A.4.10.1.1) and dilute to 100 ml with ethanol.

A.4.10.2.2 Solution 2

Dilute 10 ml of solution 1 (A.4.10.2.1) to 100 ml with ethanol.

A.4.10.2.3 Standard solutions A to E

- a) Solution A: Dilute 20 ml of solution 2 (A.4.10.2.2) to 100 ml with extraction solvent (A.4.10.1.2) (DEHP content: 20 mg/100 ml).
- b) Solution B: Dilute 10 ml of solution 2 to 100 ml with extraction solvent (DEHP content: 10 mg/100 ml).
- c) Solution C: Dilute 5 ml of solution 2 to 100 ml with extraction solvent (DEHP content: 5 mg/100 ml).
- d) Solution D: Dilute 2 ml of solution 2 to 100 ml with extraction solvent (DEHP content: 2 mg/100 ml).
- e) Solution E: Dilute 1 ml of solution 2 to 100 ml with extraction solvent (DEHP content: 1 mg/100 ml).

A.4.10.3 Calibration curves

Measure the maximum absorbance of the standard solutions (A.4.10.2.3) at 272 nm, using the extraction solvent as the reference solution and plot a curve of absorbance against DEHP concentrations.

A.4.10.4 Extraction procedure

Fill the empty plastics container to half of the nominal capacity through the collecting tube with a volume of extraction solvent heated to 37 °C. Expel the air completely from the plastics container and seal the collecting tube. Immerse the filled plastics container in a horizontal position in a water-bath maintained at (37 ± 1) °C for (60 ± 1) min without shaking. Remove the plastics container from the water-bath, invert it gently 10 times, and transfer the contents to a glass flask.

Measure the maximum absorbance at 272 nm using the extraction solvent as the reference solution.

A.4.10.5 Expression of results

Determine the quantity of extractable DEHP by comparing the result obtained for the plastics container (see A.4.10.4) with the calibration curve of absorbance for the standard solutions (see A.4.10.3).

Annex B (normative)

Physical tests

B.1 Transparency test

Fill the empty plastics container to its nominal capacity with a volume of the primary opalescent suspension (A.4.7.2.3) diluted to an absorbance of 0,37 to 0,43 at 640 nm (dilution factor about 1:16) as measured in a cuvette with an internal light path of 1 cm.

B.2 Test for rate of collection

From a reservoir containing sufficient liquid at (37 ± 2) °C having a viscosity of $3,4 \times 10^{-6}$ m²/s at 37 °C and under pressure of 9,3 kPa, allow the plastics container to fill at a temperature of (23 ± 5) °C through a blood-taking needle with dimensions as specified in 5.7 in the same hydrostatic plane as the top of the bag.

NOTE A suitable liquid for use in this test is a solution of glucose in water (400 g/l).

B.3 Test for permanence of labelling

Store the plastics container, filled to capacity and sealed, for 24 h at a temperature of (4 ± 2) °C. Follow this initial storage period by a period of 24 h at a temperature of (-30 ± 5) °C. Then submerge the plastics container in tap water maintained at a temperature of (37 ± 2) °C for 1 h.

B.4 Test for particulate contamination

B.4.1 Inspect plastics containers containing anticoagulant and/or preservative solutions as described in B.4.3.

B.4.2 Fill, under cleanroom conditions, the empty plastics container with purified water⁴⁾ which has been filtered previously through a membrane filter of pore diameter 0,2 µm. Use a volume of water corresponding to the nominal capacity of the container.

B.4.3 Inspect the fluid in the plastics container by an appropriate method that will readily detect visible particles.

B.5 Test for sterile connection of tubing

Install and calibrate the "Sterile Welding Device" (SWD) and train users before commencing.

Check that tubing dimensions are within the SWD manufacturer's specified tolerances.

Make sterile connections between 12 cm segments for each combination of tubing shown in [Table B.1](#) in strict accordance with SWD manufacturer's instructions. Identify each weld individually.

Upon completion, visually inspect all welds for evidence of defects.

4) See e.g. European Pharmacopoeia.

Pressure test all welds for leaks by hermetically sealing one end of the tube then applying a pressure of 1,5 bar (50 kPa above atmospheric) for 10 s to the open end of the tube with the weld submerged below water. Check for emergence of air bubbles from the weld. No defects are permissible.

Measure the breaking strain of each weld by stretching the tube segment at a speed of 500 mm/min with a universal tensile tester. Each weld must withstand a minimum of 40 N at $(23 \pm 5) ^\circ\text{C}$ (see also Reference[5]).

Table B.1 — Matrix of required sterile connections and tests

Tube content	Dry/dry	Wet/wet	Dry/wet	Wet/dry
Tube X vs. tube Y	5 samples	5 samples	10 samples	10 samples

Wet condition can be achieved with either biological fluids (e.g. plasma) or anticoagulant/preservative solutions.

Annex C (normative)

Biological tests

C.1 General

For general biological tests for medical devices, see ISO 10993 series. ISO 10993-12 defines sample preparation and reference materials. Manufacturers shall conduct adequate testing to demonstrate biocompatibility.

C.2 Preparation of the test solutions

C.2.1 Test fluid I (polar extractant)

Fill the empty plastics container twice to nominal capacity with water for injection, shake for approximately 1 min, and then empty. After the rinse water has drained off, fill the empty container with enough sterile endotoxin-free sodium chloride solution⁵⁾ [$\rho(\text{NaCl}) = 9 \text{ g/l}$] so that the ratio of the inner surface of the empty container, expressed in square centimetres, to the volume of sodium chloride solution, expressed in millilitres, is at least 6:1. Then compress the container so that the remaining air escapes from the container, and close it. If the container is packed in an outer bag, extract it for at least (60 ± 12) min in pressurized, saturated steam at $(121 \pm 2) \text{ }^\circ\text{C}$. Perform the extraction on a sufficient number of containers so that at least approximately 250 ml of extract is available. Mix the extracts from the individual containers after they have cooled. Treat in a flask in the same manner 250 ml of the sterile, endotoxin-free isotonic sodium chloride solution as comparison fluid (blank sample).

C.2.2 Test fluid II (non-polar extractant)

Prepare the test fluid II in the same manner as the test fluid I according to C.2.1, but

- dry the empty containers after being rinsed with water for injection at $50 \text{ }^\circ\text{C}$ for 1 h, or until moisture can no longer be determined by visual inspection;
- use sesame oil for parenteral⁶⁾ use or cottonseed oil⁷⁾ as extraction agent;
- use sesame oil for parenteral⁶⁾ use or cottonseed oil⁷⁾ as comparison fluid, according to the extraction agents used;
- use the non-polar extractant mentioned in the specific biological test.

C.3 Test for impermeability to microorganisms

Fill empty containers to their nominal capacity under sterile conditions with a culture medium, e.g. casein peptone-soybean flour peptone bouillon (CaSo), and seal. Immerse the containers, or the appropriate parts of the containers, in a suspension (approximately 10^6 CFU/ml) of challenge organism (e.g. *Bacillus atropheus*, NCTC 10073) for at least 30 min. Remove the containers from the challenge suspension and rinse with sterile water. Incubate the containers for at least 7 days at a temperature appropriate for the challenge organism (e.g. $37 \text{ }^\circ\text{C}$ for *Bacillus atropheus*).

5) See e.g. European Pharmacopoeia.

6) See European Pharmacopoeia or United States Pharmacopoeia.

7) United States Pharmacopoeia.

A container which is prepared in the same manner, and the contents of which are inoculated with 1 ml of a culture of challenge organism, serves as the positive control article. Alternatively, prepare the positive control article by compromising a unit filled with culture medium. This may be accomplished by puncturing the particular area of the container being challenged.

Examine the contents for microbial growth. Positive controls shall exhibit turbidity. Test articles shall not be turbid.

C.4 Test for bacterial endotoxins

Perform tests for bacterial endotoxins according to the relevant pharmacopoeia.

C.5 Test for cytotoxicity

Perform cytotoxicity testing according to ISO 10993-5.

C.6 Test for haemolysis

C.6.1 General

See also ISO 10993-4.

C.6.2 Preparation of the erythrocyte suspension

Dilute one part by volume of freshly taken human blood, which has been anticoagulated according to the national pharmacopoeia, with five parts by volume of a sterile sodium chloride solution [$\rho(\text{NaCl}) = 9 \text{ g/l}$] and centrifuged for 5 min in a centrifuge at 1 500 *g* to 2 000 *g*. Aspirate the supernatant solution and repeat treatment of the erythrocytes under the same conditions and with the same volume of sodium chloride solution.

Dilute the erythrocytes obtained in this way at a ratio of 1:9 with a sterile sodium chloride solution [$\rho(\text{NaCl}) = 9 \text{ g/l}$]. This suspension may be used for 6 h at most when stored at room temperature.

C.6.3 Procedure

Evaporate at a temperature of 100 °C 125 ml of test fluid prepared according to A.3. Dissolve the evaporation residue in 5 ml sterile sodium chloride solution [$\rho(\text{NaCl}) = 9 \text{ g/l}$], mixed with 1 ml of the erythrocyte suspension and kept for 20 min at 37 °C \pm 1 °C. Then centrifuge the mixture for 5 min at 1 500 *g* to 2 000 *g*.

Prepare the control solution simultaneously under the same conditions, but without addition of the evaporation residue of the test solution.

Measure the absorbance of the test solution against the control solution at 540 nm in a cuvette with an internal light path of 1 cm. The absorbance of the test solution shall not differ from that of the control solution by more than 10 %.

NOTE Volatile constituents in the test solution cannot be detected by the test described. However, concentration of the test solution should lead to a higher sensitivity of the test.

C.7 Biological test methods

Biological test methods are given in [Table C.1](#).

ISO 10993-1 should be considered as guidance when assessing biological safety.

Table C.1 — Biological test methods

Reference	Biological test	Test method recommended for use where national regulations do not exist
C.7.1	Interaction with blood	ISO 10993-4 ^a
C.7.2	Cell culture cytotoxicity	ISO 10993-5 United States Pharmacopeia, Biological Reactivity Tests, <i>In-vitro</i> <87>
C.7.3	Haemolysis	ISO 10993-4 European Pharmacopoeia (chapter 3.2.3)
C.7.4	Systemic injection (acute toxicity)	ISO 10993-11 United States Pharmacopeia, Biological Reactivity Tests, <i>In vivo</i> <88>
C.7.5	Sensitization	ISO 10993-10
C.7.6	Intracutaneous injection (Irritation)	ISO 10993-10 United States Pharmacopeia, Biological Reactivity Tests, <i>In vivo</i> <88>
C.7.7	Testing for pyrogens	European Pharmacopoeia (chapter 2.6.8) United States Pharmacopeia (General Tests and Analysis, <151>) Japanese Pharmacopoeia (chapter 4.04)
^a Proposed selection of test for interaction with blood: Level 1 – Blood path indirect; Level 2 – Circulating blood.		

Bibliography

- [1] European Pharmacopoeia
- [2] United States Pharmacopeia
- [3] EC GMP Good Manufacturing Practice (see http://ec.europa.eu/enterprise/sectors/pharmaceuticals/documents/eudralex/vol-4/index_en.htm).
- [4] EN 15986, *Symbol for use in the labelling of medical devices — Requirements for labelling of medical devices containing phthalates*
- [5] NIGHTINGALE M.J., LEES B., BISET R., MERTENS W. Use of a (proposed) standard protocol to validate Terumo TSCD-II connections between dissimilar blood bag tubing. *Vox Sang.* 2006, **91** pp. 241–269
- [6] NIGHTINGALE M.J. Improving compatibility between blood packs and transfusion sets. *Transfus. Med.* 2006, **16** pp. 11–15
- [7] NIGHTINGALE M.J., & LEIMBACH R. An evaluation of proposed changes to International Standards for blood bags and transfusion sets to improve their compatibility. *Transfus. Med.* 2008, **18** pp. 281–286
- [8] ISO 9626:1991/Amd.1:2010, *Stainless steel needle tubing for the manufacture of medical devices; Amendment 1*
- [9] ISO 3826-2, *Plastics collapsible containers for human blood and blood components — Part 2: Graphical symbols for use on labels and instruction leaflets*
- [10] ISO 3826-3, *Plastics collapsible containers for human blood and blood components — Part 3: Blood bag systems with integrated features*
- [11] ISO 15223-1, *Medical devices — Symbols to be used with medical device labels, labelling and information to be supplied — Part 1: General requirements*