**Acoustics — Laboratory tests on noise
emission from appliances and equipment
used in water supply installations —**

**Part 1:
Method of measurement**

*Acoustique — Mesurage en laboratoire du bruit émis par les robinetteries
et les équipements hydrauliques utilisés dans les installations de
distribution d'eau —*

Partie 1: Méthode de mesurage



Reference number
ISO 3822-1:1999(E)

© ISO 1999

Foreword

ISO (the International Organization for Standardization) is a worldwide federation of national standards bodies (ISO member bodies). The work of preparing International Standards is normally carried out through ISO technical committees. Each member body interested in a subject for which a technical committee has been established has the right to be represented on that committee. International organizations, governmental and non-governmental, in liaison with ISO, also take part in the work. ISO collaborates closely with the International Electrotechnical Commission (IEC) on all matters of electrotechnical standardization.

International Standards are drafted in accordance with the rules given in the ISO/IEC Directives, Part 3.

Draft International Standards adopted by the technical committees are circulated to the member bodies for voting. Publication as an International Standard requires approval by at least 75 % of the member bodies casting a vote.

Attention is drawn to the possibility that some of the elements of this part of ISO 3822 may be the subject of patent rights. ISO shall not be held responsible for identifying any or all such patent rights.

International Standard ISO 3822-1 was prepared by the European Committee for Standardization (CEN) in collaboration with ISO Technical Committee TC 43, *Acoustics*, Subcommittee SC 2, *Building acoustics*, in accordance with the Agreement on technical cooperation between ISO and CEN (Vienna Agreement).

Throughout the text of this standard, read "...this European Standard..." to mean "...this International Standard...".

This third edition cancels and replaces the second edition (ISO 3822-1:1983), which has been technically revised.

ISO 3822 consists of the following parts, under the general title *Acoustics — Laboratory tests on noise emission from appliances and equipment used in water supply installations*:

- *Part 1: Method of measurement*
- *Part 2: Mounting and operating conditions for draw-off taps and mixing valves*
- *Part 3: Mounting and operating conditions for in-line valves and appliances*
- *Part 4: Mounting and operating conditions for special appliances*

Annex C forms a normative part of this part of ISO 3822. Annexes A and B are for information only.

© ISO 1999

All rights reserved. Unless otherwise specified, no part of this publication may be reproduced or utilized in any form or by any means, electronic or mechanical, including photocopying and microfilm, without permission in writing from either ISO at the address below or ISO's member body in the country of the requester.

ISO copyright office
Case postale 56 • CH-1211 Geneva 20
Tel. + 41 22 749 01 11
Fax + 41 22 734 10 79
E-mail copyright@iso.ch
Web www.iso.ch

Printed in Switzerland

Contents

Page

Foreword.....	iv
Introduction.....	v
1 Scope	1
2 Normative references	1
3 Definitions	1
4 Principle.....	3
5 Test arrangement (see figure 1)	3
5.1 Test room.....	3
5.2 Correction for background noise.....	4
5.3 Test wall.....	4
5.4 Test pipe	4
5.5 Connection of appliances	6
5.6 Water supply system.....	6
5.7 Stabilising and checking the test arrangement.....	6
5.8 Measurement of intrinsic noise of installation arrangement	8
6 Test equipment	9
6.1 Sound level meter and filters.....	9
6.2 Hydraulic measuring instruments.....	9
7 Installation noise standard	9
8 Test procedure	12
8.1 General.....	12
8.2 Determination of appliance sound pressure level L_{ap}	12
9 Expression of results	13
10 Test report	13
Annex A (informative) Procedure for venting the piping system (test pipe and twin outlet etc.).....	14
Annex B (informative) Alternative procedures for measurements for computer-aided test facilities	16
Annex C (normative) Selection of samples.....	17

Foreword

The text of EN ISO 3822-1:1999 has been prepared by Technical Committee CEN/TC 126 "Acoustic properties of building products and of buildings", the secretariat of which is held by AFNOR, in collaboration with Technical Committee ISO/TC 43 "Acoustics".

This European Standard shall be given the status of a national standard, either by publication of an identical text or by endorsement, at the latest by November 1999, and conflicting national standards shall be withdrawn at the latest by November 1999.

The content of this part of EN 3822 is not identical with the International Standard ISO 3822-1:1983 "Acoustics - Laboratory tests on noise emission from appliances and equipment used in water supply installations - Part 1 : Method of measurement".

Working group CEN/TC 126/WG 3 was instructed, in May 88, to examine and take into account the comments on ISO 3822-1, following the primary questionnaire.

According to the CEN/CENELEC Internal Regulations, the national standards organizations of the following countries are bound to implement this document : Austria, Belgium, the Czech Republic, Denmark, Finland, France, Germany, Greece, Iceland, Ireland, Italy, Luxembourg, Netherlands, Norway, Portugal, Spain, Sweden, Switzerland, and the United Kingdom.



Introduction

Noise caused by water supply installations may lead to annoyance in adjacent rooms, for example in dwellings, hospitals and hotels, especially at night. This noise has its origin mainly in appliances. Standardised measurements of such noise are needed to permit comparison of the noise of commercial products made in different countries.

This part of EN ISO 3822 describes a method of measurement allowing comparable results to be obtained in laboratory measurements.

It is not possible to describe in detail how a given tap would give the same result in different laboratories. Therefore, the principle of comparing results to an installation noise standard is utilised. This procedure can be regarded as a kind of calibration of the test arrangement. The installation noise standard is described in detail and the basic arrangements for a laboratory water supply installation are given in this part of EN ISO 3822.

The test conditions described herein constitute the standard reference conditions essential for comparisons between laboratories.

Descriptions of the mounting and operating conditions for testing different types of appliances are given in other parts of this European Standard : see EN ISO 3822-2 for draw-off taps and mixing valves, EN ISO 3822-3 for in-line valves and EN ISO 3822-4 for special appliances.

1 Scope

This part of EN ISO 3822 specifies a method of measurement, in the laboratory, of the noise emission resulting from the flow of water through appliances and equipment used in water supply installations.

The items covered include draw-off taps, in-line valves and special appliances, for example pressure reducers and water-heating appliances, all of which are hereafter referred to as "appliances".

The method specified makes it possible to obtain comparable results of measurements in different laboratories.

2 Normative references

This European Standard incorporates by dated or undated reference, provisions from other publications. These normative references are cited at the appropriate places in the text and the publications are listed hereafter. For dated references, subsequent amendments to or revisions of any of these publications apply to this European Standard only when incorporated in it by amendment or revision. For undated references the latest edition of the publication referred to applies.

ISO 7-1, *Pipe threads where pressure-tight joints are made on the threads - Part 1 : Dimensions, tolerances and designation.*

ISO 49, *Malleable cast iron fittings threaded to ISO 7-1.*

ISO 65, *Carbon steel tubes suitable for screwing in accordance with ISO 7-1.*

EN ISO 3822-2, *Acoustics - Laboratory tests on noise emission from appliances and equipment used in water supply installations - Part 2 : Mounting and operating conditions for draw-off taps and mixing valves (ISO 3822-2: 1995).*

EN ISO 3822-3, *Acoustics - Laboratory tests on noise emission from appliances and equipment used in water supply installations - Part 3 : Mounting and operating conditions for in-line valves and appliances (ISO 3822-3:1997).*

EN ISO 3822-4, *Acoustics - Laboratory tests on noise emission from appliances and equipment used in water supply installations - Part 4 : Mounting and operating conditions for special appliances.*

EN 60651, *Sound level meters.*

EN 61260, *Electroacoustics - Octave band and fractional-octave-band filters.*

3 Definitions

For the purposes of this standard the following definitions apply :

3.1

octave band sound pressure level, in decibels

the unweighted sound pressure level in the frequency band of one octave. In this part of EN ISO 3822 octave band sound pressure levels and sound pressure level differences are denoted by the subscript n.

3.2

a-weighted sound pressure level, in decibels

the sound pressure level weighted with the A-weighting specified in EN 60651

**3.3
appliance sound pressure level, L_{apn} for octave bands**

a quantity defined by :

$$L_{apn} = L_n - (L_{sn} - L_{srn}) \quad (1)$$

where

- L_n is the average octave band sound pressure level in octave n , in the test room, due to the noise produced by the appliance under the specified test conditions ;
- L_{sn} is the corresponding octave band sound pressure level in the test room due to the noise produced by the installation noise standard (abbreviation INS) at a flow pressure of 0,3 Mpa ¹⁾ (see clause 7) ;
- L_{srn} is the reference value of the octave band sound pressure level in the octave n for the INS at flow pressure of 0,3 MPa (see clause 7).

**3.4
appliance sound pressure level, L_{ap} in decibels**

the A-weighted sound pressure level, which is a characteristic value for the noise emission by an appliance. It is defined, in decibels, by :

$$L_{ap} = 10 \lg \sum_{n=1}^6 10^{\frac{[L_n - (L_{sn} - L_{srn}) + k(A)_n]}{10}} \text{ dB} \quad (2)$$

where

- $n = 1, 2, 3, \dots, 6$ are the octaves with mid-frequencies from 125 Hz to 4 000 Hz ;
- $k(A)_n$ are the A-weighting values, in decibels, given in EN 60651 for the six octave mid-frequencies from 125 Hz to 4 000 Hz.

When the sound pressure level difference ($L_{sn} - L_{srn}$) at the octave band mid-frequencies from 125 Hz to 4 000 Hz is constant to within ± 2 dB (see clause 8), the appliance sound pressure level L_{ap} may be obtained directly from the A-weighted sound pressure levels as follows :

$$L_{ap} = L - (L_s - L_{sr}) \quad (3)$$

where

- L is the average A-weighted sound pressure level in the test room due to the noise produced by the appliance under the specified test conditions ;
- L_s is the average A-weighted sound pressure level in the test room due to the noise produced by the INS at a flow pressure of 0,3 MPa ;
- L_{sr} is the reference A-weighted sound pressure level of the INS at a flow pressure of 0,3 MPa (see clause 7).

The appliance sound pressure level L_{ap} shall always be given rounded to the nearest whole decibel.

¹⁾ 1 MPa = 10 bar

4 Principle

The appliance to be tested is mounted at the end of a water pipe, the test pipe, which is fixed to the wall of a room. The wall is called the test wall, the room the test room (see figure 1).

The sound generated by the appliance is transmitted from the test pipe to the test wall. The airborne sound which is radiated from the test wall into the test room is measured.

In order to obtain comparable measurements in different laboratories, the noise produced by the appliance is compared with the noise produced by an installation noise standard.

5 Test arrangement (see figure 1)

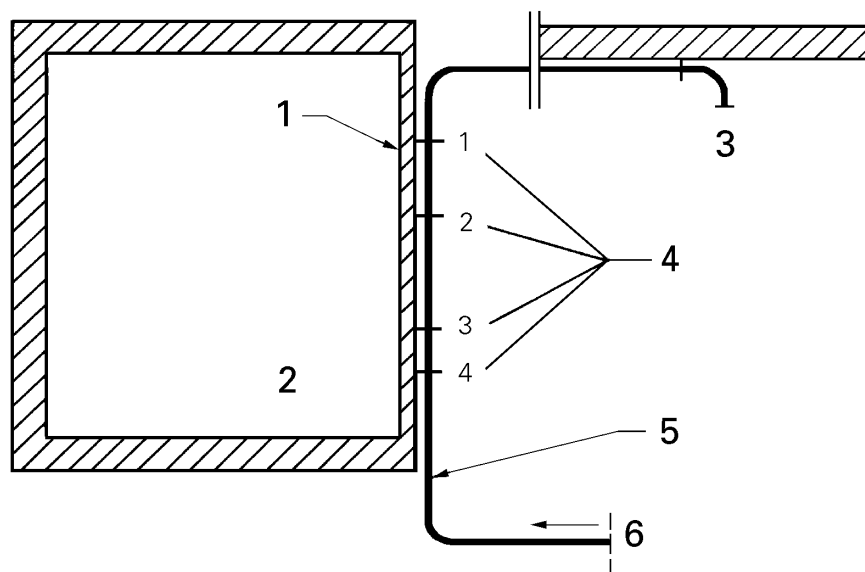

Legend

- 1 Test wall
- 2 Test room
- 3 Appliance connection
- 4 Fixing point 1 to 4
- 5 Test pipe
- 6 From the water supply system

Figure 1 - Example of test arrangement

5.1 Test room

The test room shall have a volume of at least 30 m³. For new laboratories a volume of approximately 50 m³ is recommended.

Two opposite surfaces of the test room shall not be less than 2,3 m apart.

In the test room, the reverberation time should be between 1 s and 5 s for the octave bands with mid-frequencies from 125 Hz to 2 000 Hz.

The sound field in the test room should be as diffuse as possible.

5.2 Correction for background noise

Measurements of background noise levels shall be made to ensure that the measurements in the test room are not affected by extraneous sound such as noise from outside the test room, electrical noise in the receiving system, or structure born sound not originating from the appliance under test. The background level shall be at least 6 dB (and preferably more than 15 dB) below the level of signal and background noise combined.

If the difference in levels is smaller than 15 dB but greater than 6 dB, calculate corrections to the signal level according to the equation :

$$L = 10 \lg \left(10^{L_{sb}/10} - 10^{L_b/10} \right) \text{dB} \quad (4)$$

where

L is the adjusted signal level, in decibels ;

L_{sb} is the level of signal and background noise combined, in decibels ;

L_b is the background noise level, in decibels.

If the difference in levels is less than or equal to 6 dB in any of the frequency bands, use the correction 1,3 dB corresponding to a difference of 6 dB. In that case, L_{ap} shall be given in the test report so that it clearly appears that the reported L_{ap} values are the limit of measurement.

5.3 Test wall

The test wall shall have an area of 8 m² to 12 m².

It shall be a single wall of masonry or poured concrete and shall have a mass per unit area between 100 kg/m² and 250 kg/m².

5.4 Test pipe

The test pipe shall be a galvanised steel tube of medium series complying with the requirements of ISO 65 with a nominal bore of 25 mm (1 inch).

The test pipe shall be fixed to the test wall outside the test room. It shall be mounted rigidly and durably, approximately in the middle of the wall, in a straight line, by means of four brackets, spaced unequally over approximately the whole length of the wall. The pipe shall be clamped rigidly in the brackets (without insulation). The brackets shall be in accordance with figure 2. There shall be no other connections between the test pipe and the test wall. The test pipe shall be accessible for periodic inspection of the mounting.

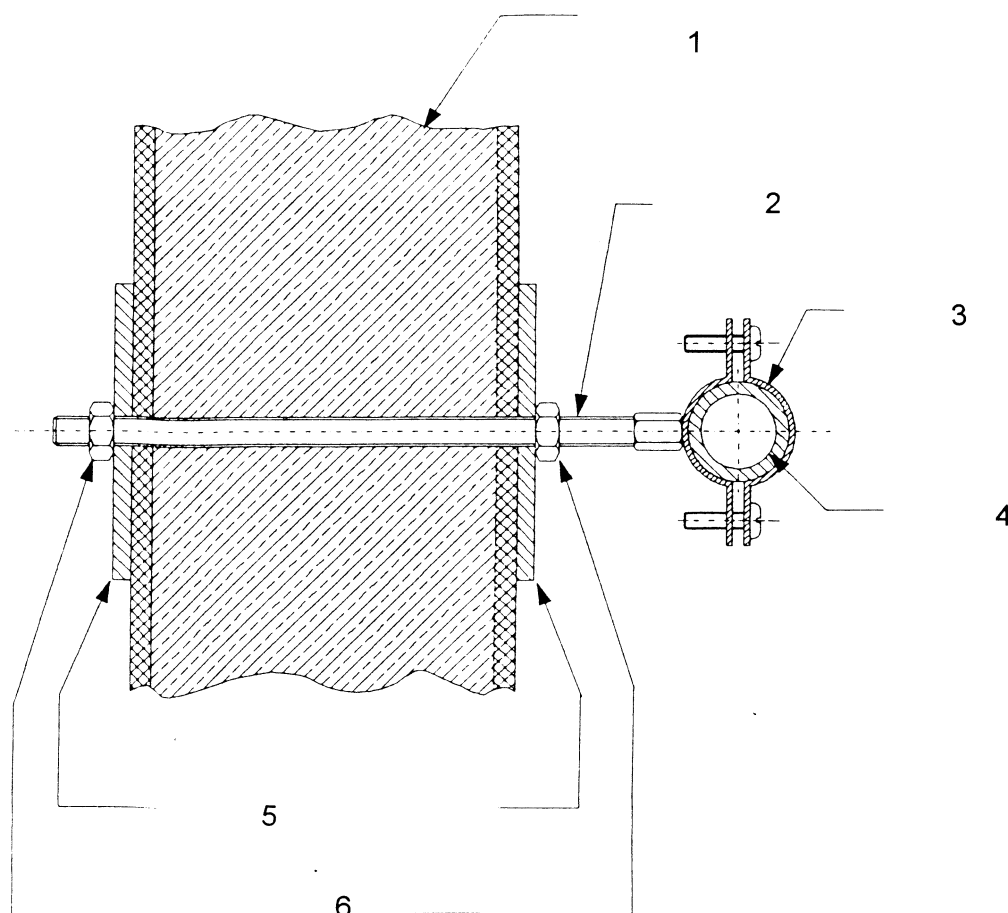

Legend

- 1 Test wall
- 2 Metal stud M10
- 3 Metal clamp with welding nut, galvanized, without insulation
- 4 Test pipe
- 5 Steel plate (6 ± 1) mm thick; area (100 ± 20) cm²
- 6 Nut M10

Figure 2 - Bracket for mounting test pipe on the test wall

It shall be possible to vent the test pipe at all high points, for example by using drain valves. It is recommended that the test pipe be mounted sloping slightly upwards in the direction of flow.

The test pipe shall include a twin outlet so that appliances with two inlets can be mounted. A galvanized (hot zinc dip coated) union, taper seat, ISO 49-U11-1, shall be provided at the downstream end of each branch of the twin outlet. Immediately adjacent to each of these unions there shall be a full-bore, quarter-turn spherical plug valve, size DN25, so that the test pipe can be kept under pressure at all times, even when the appliance is exchanged or to connect the installation noise standard. The ISO 49-U11-1 unions are regarded as the end of the test pipe. The length of test pipe between these unions and the first fixing on the test wall (see figure 1) shall be between 2 m and 10 m.

The twin outlet shall be in accordance with figure 3. Only galvanized fittings complying with ISO 49 shall be used. The straight portions of the two main branches shall be of galvanized steel tube of medium series complying with ISO 65 with a nominal bore of 25 mm (1 inch). They shall be arranged for either vertically upward or vertically downward flow. Upstream of the division into the two branches of the twin outlet there shall be a branch for connecting a pressure gauge (see figure 3). The sensing unit for measuring the pressure shall be attached directly,

without additional coupling volume, to the ½ outlet of the tee (9) in figure 3. The twin outlet assembly shall be fixed rigidly with 4 brackets to a heavy wall other than the test wall. This heavy wall shall have a mass per unit areas of at least 200 kg/m² and measure at least 1,5 m by 1,8 m. It shall be acoustically isolated from other structures to avoid structure borne noise transmission.

The A-weighted sound pressure levels measured at the twin outlet for the INS (see clause 7) shall not differ by more than 1 dB and the octave band sound pressure levels shall not differ by more than 2 dB.

5.5 Connection of appliances

Details of the connections for testing different types of appliances are given in other parts of this European Standard.

A flow meter shall not be placed between the appliance to be tested and the part of the test pipe mounted on the test wall, nor shall the flow meter be mounted on the test wall or any other wall of the test room.

5.6 Water supply system

The water supply system shall be so designed that tests can be carried out over the usable range of flow pressure and flow rate of the appliances to be tested.

NOTE As a rule, for draw-off taps as used in dwellings, the following ranges are sufficient :

- flow pressure : up to 0,5 MPa ;
- flow rate : up to 2 l/s ;

For testing pressure regulators, a flow pressure range up to 1 MPa is recommended.

The intrinsic noise of the water supply system shall be insulated from the test pipe and the test room, if necessary by means of silencing devices. The water used during the test shall be discharged quietly. The water temperature shall not be more than 25 °C.

5.7 Stabilising and checking the test arrangement

Before beginning measurements with the INS or on the appliances to be tested, the test arrangement shall be stabilised by meticulous venting.

NOTE Annex A (informative) provides a procedure for venting.

It is recommended that a control INS complying with the requirements of clause 7 is provided for regular supervision of the test arrangement, as shown in figure 3.

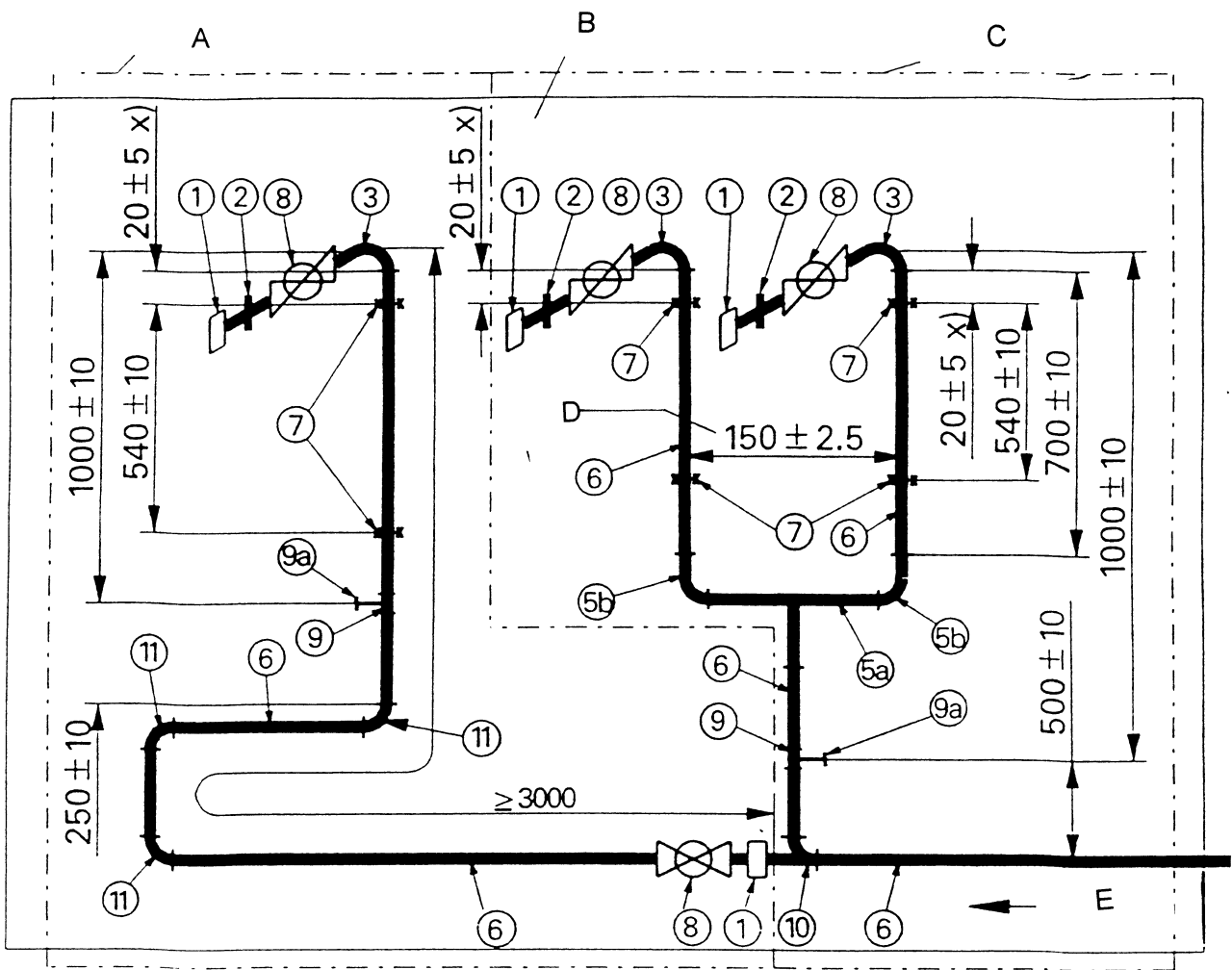

Legend

- A Connection for control INS
- B Wall for mounting the twin outlet
- C Twin outlet
- D Distance : center line pipe
- E From test wall
- x) Distance between bracket and long sweep bend G4

Figure 3 a) - Twin outlet and connection for control INS

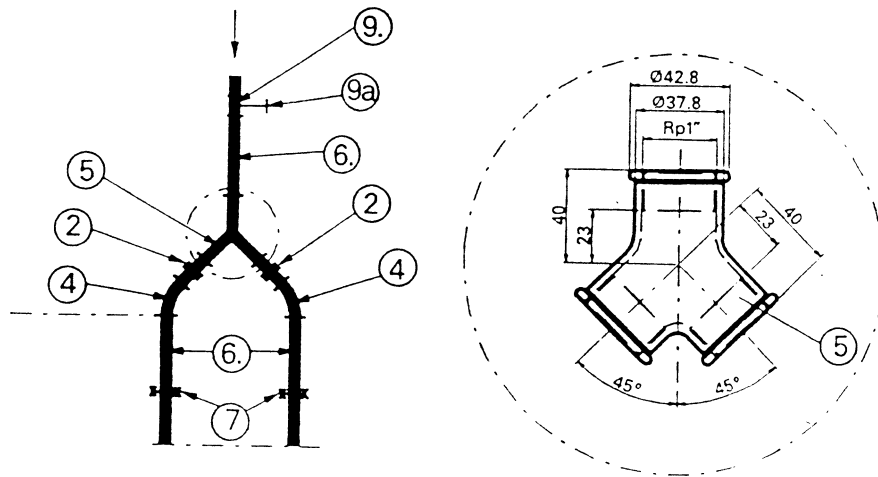

Legend

Galvanised pipe fittings complying with ISO 49 :

- 1 Union, taper seat 1, U11
- 2 Double Hexagon nipple 1, N8
- 3 Long sweep bend 1, G4
- 4 Long sweep bend 1, G 1/45°
- 5a Tee 1, B1
- 5b Elbow 1, A4
- 5 Galvanised Y-piece 1, 2x45° branching (fig. 3a)
- 6 Galvanised steel tube, medium series, DN25, complying with ISO 65
- 7 Rigid metal brackets
- 8 Full-bore quarter turn spherical plug valves
- 9a Connection for pressure gauge
- 9 Tee 1x1/2, B1, branching reduced
- 10 Pitcher tee 1, E1
- 11 Long sweep bend 1, G1

Figure 3 b) – Alternative (not preferred)

5.8 Measurement of intrinsic noise of installation arrangement

The intrinsic noise of the installation arrangement (water supply system, test pipe, connection of appliances) shall be measured. For this purpose, the appliance connection shall be fitted with a low-noise water outlet. The test shall be carried out at various flow rates.

The sound pressure level of the intrinsic noise shall be considerably lower than that of the appliance to be tested (at least 10 dB).

6 Test equipment

6.1 Sound level meter and filters

Sound level meters complying at least with the requirements for Type 1 of EN 60651 shall be used, the time weighting characteristic "F" being recommended.

Alternative measuring equipment, including for example a level recorder, may be used provided its overall electro-acoustic performance complies at least with the relevant clauses of the Type 1 requirements of EN 60651.

Octave band filters, when used, shall comply with the requirements of EN 61260.

6.2 Hydraulic measuring instruments

The instrument for measuring flow pressure shall be accurate to $\pm 1\%$ of reading.

The flow rate shall be determined with an accuracy of $\pm 2\%$.

NOTE As the accuracy of the flow meter depends significantly on the installation, its accuracy should be checked in situ.

7 Installation noise standard

The noise produced by the appliance under test depends on the physical properties of the test arrangement.

To make it possible to compare results from different laboratories, it is therefore necessary also to measure the noise produced by the installation noise standard (INS) in each laboratory. The INS is mounted at the end of the test pipe in place of the appliance under test and in accordance with the arrangement shown in figure 5.

The installation noise standard shall be made of brass and comply with figure 4. The holes shall be sharp edged but free from burrs. Where a surface finish of 0,4 is specified, this shall be on all surfaces.

For the correct operation of the INS, a straight flexible hose (item 5 in figure 5) shall be fitted to the tail of the hose union (item 4 in figure 5). This hose shall have a length of (500 ± 5) mm with an inside diameter of $(13 \pm 0,5)$ mm and a wall thickness of $(3 \pm 0,3)$ mm.

NOTE Care should be taken to ensure that the INS remains free from corrosion and foreign matter.

The reference values of the octave band sound pressure levels L_{SRn} for the INS at a flow pressure of 0,3 MPa are given in table 1.

Table 1 - Reference values for the octave band sound pressure levels, L_{SRn} , for the INS at a flow pressure of 0,3 MPa

Mid-frequency of the octave band Hz	Reference octave band sound pressure level, L_{SRn} dB
125	35
250	39
500	42
1 000	42
2 000	37
4 000	25

The reference A-weighted sound pressure level of the INS, L_{SR} at a flow pressure of 0,3 MPa is 45 dB.

Dimensions in millimetres

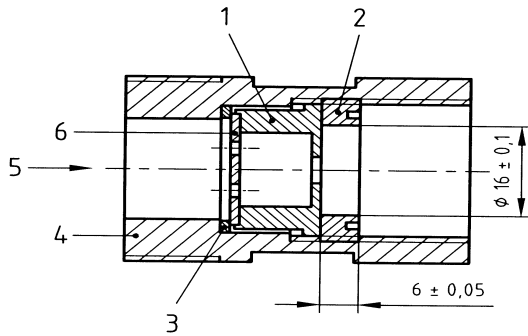

Figure 4a) - Assembly

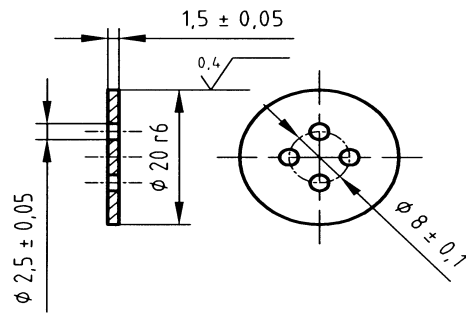

Figure 4b) - Diaphragm of insert

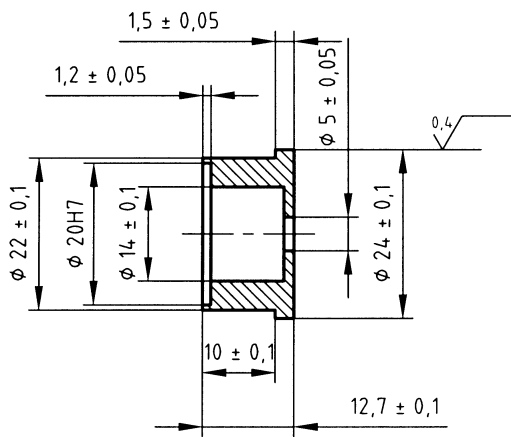
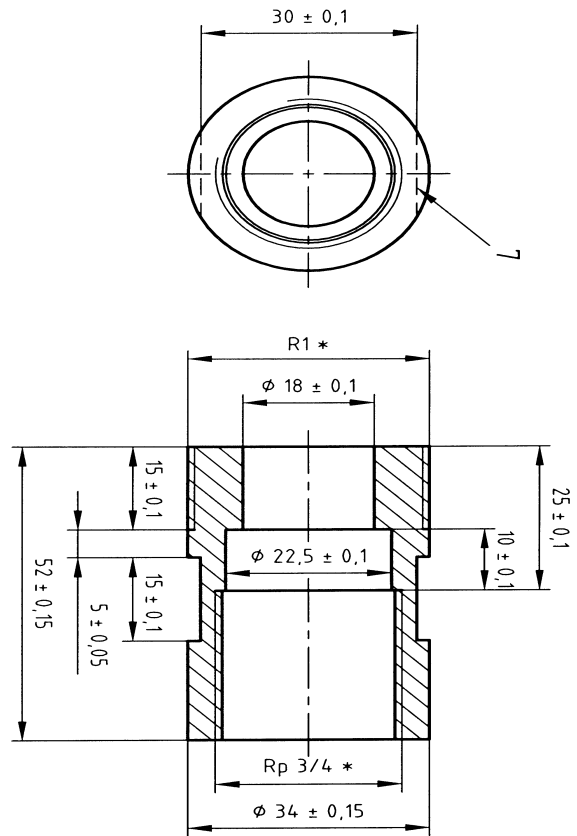

Figure 4c) - Body of insert



* See ISO 7-1

Figure 4d) - Receptacles

Legend

- 1 Body of insert
- 2 Threaded ring
- 3 Sealing washer
- 4 Receptacle
- 5 Direction of flow
- 6 Diaphragm of insert
- 7 Two flats or six flats in hexagonal

Figure 4 - Installation noise standard

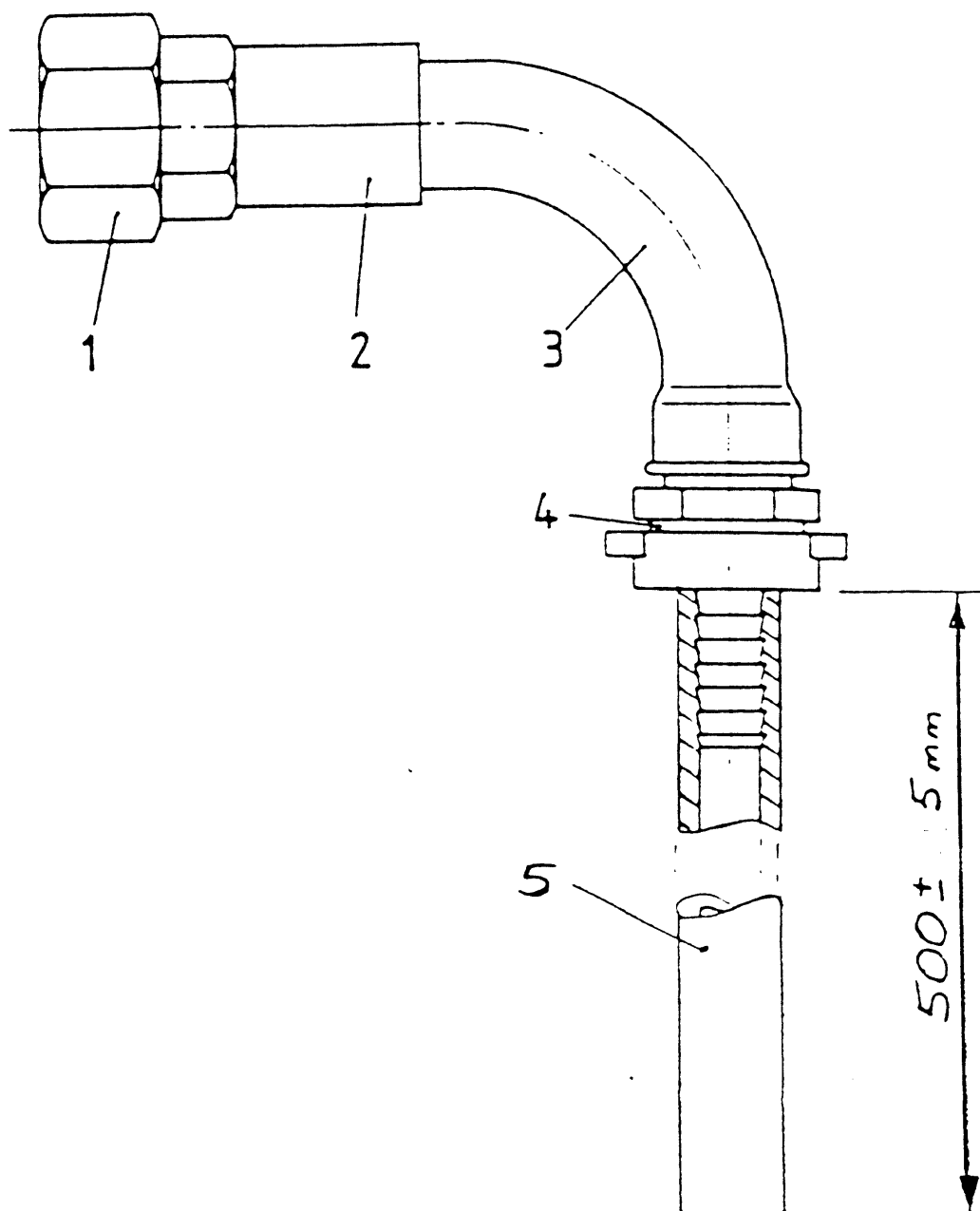

Legend

- 1 Union, taper seat ISO 49-U11-1, galvanised
- 2 Assembled INS complying with figure 4
- 3 Male and female long sweep bend, ISO 49-G4- $\frac{3}{4}$, galvanised
- 4 Threaded hose union, R $\frac{3}{4}$, complying with the requirements of ISO 7-1, with brass hose tail for flexible hose of internal diameter 13 mm
- 5 Flexible hose of internal diameter ($13 \pm 0,5$) mm and wall thickness ($3 \pm 0,3$) mm

Figure 5 - Arrangement for using the installation noise standard (INS)

8 Test procedure

The test conditions specified in other parts of this European Standard shall be applied to three samples of the appliance under test. The selection of samples from a range of products of similar design shall be in accordance with annex C.

8.1 General

Since air contained in the test arrangement, even in small quantities, will significantly influence the results, it is essential to vent all parts of the test arrangement thoroughly before and, if necessary, during a test. It is particularly important to thoroughly vent the unused branch of the twin outlet when testing appliances with only one inlet (see Annex A for a procedure for venting).

To improve accuracy of measurements, more than one microphone position may be necessary. The need for this can be determined by preliminary measurements in the test room. The microphone of the sound level meter shall be kept at least 1m from the boundary surfaces of the room.

8.2 Determination of appliance sound pressure level L_{ap}

In order to determine the appliance sound pressure level L_{ap} of appliances with two inlets, the mean of the 2 values of the INS sound pressure level L_s obtained for the twin outlet shall be used in equation (3). For measurement in octave bands, the mean of the 2 values of the INS octave band sound pressure level L_{sn} obtained for the twin outlet shall be used in equations (1) and (2).

As stated in 3.4, L_{ap} may be determined from measurements of the average A-weighted sound pressure levels L and L_s using equation (3) if the sound pressure difference ($L_{sn} - L_{srn}$) for the given test arrangement is constant to within ± 2 dB in the octave bands with mid-frequencies from 125 Hz to 4 000 Hz.

In the test arrangements where the above condition does not hold, one of the following procedures shall be used.

8.2.1 Sequential measurements in octave bands

Measurements of the average octave band sound pressure levels L_n and L_{sn} are carried out sequentially at mid-frequencies from 125 Hz to 4 000 Hz. L_{ap} is then calculated using equation (2).

NOTE Manual measurements made using this method are laborious and become difficult when the noise generated by the appliance under test varies.

8.2.2 Parallel measurements in octave bands

Sequential analyses of L_n and L_{sn} as in 8.2.1 can be avoided if an adjustable equalising filter (i.e. an octave band summing filter) is added to the sound pressure level measuring equipment. This filter shall be adjusted so that ($L_{sn} - L_{srn}$) is constant to within ± 1 dB in the octave bands with mid-frequencies from 125 Hz to 4 000 Hz. L_{ap} is then determined from L and L_s using equation (3).

A further simplification of measurements may be achieved by adjusting the equalising filter so that ($L_{sn} - L_{srn}$) equals zero to within ± 1 dB in the octave bands with mid-frequencies from 125 Hz to 4 000 Hz, resulting in an A-weighted sound pressure level for the INS of $L_s = 45$ dB. In this case, the A-weighted sound pressure level of the appliance under test, L , is the appliance sound pressure level L_{ap} .

NOTE Where computer aided test facilities exist Annex B (informative) describes another technique which may be used.

9 Expression of results

Provided that the acoustic properties of the test room are not changed during the period of measurement with the installation noise standard and the appliance under test, the noise emission of the appliance shall be expressed by the appliance sound pressure level L_{ap} as defined in 3.4.

The value of the appliance sound pressure level L_{ap} , to be used for rating purposes shall be determined as follows :

For each sample, the maximum of all the values of L_{ap} obtained for the operating conditions tested shall be established. These maximum L_{ap} values of the three samples shall be arithmetically averaged. If the maximum L_{ap} value of each individual sample deviates by no more than 3 dB from this average, then this average value shall be used for the rating. If the deviation is more than 3 dB, the maximum L_{ap} value of the loudest sample shall be used for the rating.

10 Test report

The test report shall include the following information :

- a) date of test ;
- b) name and address of the organisation that has performed the measurements ;
- c) volume of the test room ;
- d) reverberation time of the test room in octave-bands with mid-frequencies from 125 Hz to 4 000 Hz ;
- e) size, mass per unit area and type of test wall ;
- f) test procedure used (see 8.2) ;
- g) sufficient identification of the appliance which has been tested and the type of connection to the test pipe ;
- h) appliance sound pressure level L_{ap} of all the operated conditions tested for each of the three samples of the appliance under test. In addition, the L_{ap} value that is to be used for the rating shall be given (see clause 9) ;
- i) reference to this European Standard.

For diagrams, the following rules apply :

- 10 dB \cong 20 mm ;
- 10 : 1 \cong 50 mm for a logarithmic flow scale ;
- 1 octave \cong 15 mm.

Annex A (informative)

Procedure for venting the piping system (test pipe and twin outlet etc.)

A.1 Measurement with the INS

- Screw the arrangement of the INS shown in figure 5 onto the male union thread of the U11 union at the end of the right hand branch of the twin outlet ;
- Hand tighten the union nut ;
- Adjust the water pressure up to 0,3 MPa approximately ;
- Slowly and partially open the ball valve in the left hand branch, so that water flows out ;
- Slowly open fully the ball valve in the right hand branch ;
- Loosen the right hand union nut while the ball valve is open, so that water can flow out (if necessary cover the union with e.g. rag to prevent splashing), at the same time turn and tilt the union parts ;
- Tighten the right hand union nut, close the ball valve in the left hand branch ;
- Raise the water pressure to at least 0,5 MPa ;
- Abruptly and repeatedly open and close the ball valve in the right hand branch ;
- Vent the test pipe at all high points ;
- Adjust the water flow pressure to 0,3 MPa ;
- Measure the L_{SN} values of the INS at the right hand branch several times, and ascertain repeatability ;
- If the L_{SN} values are not repeatable, repeat the procedure until repeatable values are attained ;
- Remove the INS arrangement and screw it onto the male union thread of the U 11 union at the end of the left hand branch of the twin outlet, hand tightening the union nut ;
- Repeat the procedure analogously for the INS at the left hand branch.

A.2 Measurements with the appliance to be tested

- Attach the appliance to ISO 49-U11-1 female half union(s) ;
- Screw the appliance/union assembly onto the male union thread of the U11 union(s) at the end of the twin outlet, hand tightening the union nut(s) ;
- Align the appliance so that it is mounted without stress and with any union type couplings on the appliance hand tight only ;
- Ensure that any flow controls and isolators in the appliance are open, and that low noise flow resistances are not fitted ;

- With the union nut(s) still only hand tight, adjust the water pressure to 0,3 MPa approximately ;
- Partially open the ball valves ;
- As water flows out, tighten the U11 union nut(s) fully (one after the other) ;
- As water flows out tighten any union type couplings on the appliance fully (one after the other) ;
- Raise the water pressure to at least 0,5 MPa ;
- Operate the valves of the appliance repeatedly and continuously, if necessary abruptly as well, in order to release stubborn air bubbles ;
- Adjust the water flow pressure to 0,3 MPa ;
- Partly close the ball valve(s) ;
- As water continues to flow, fit any low noise flow resistance required for the test ;
- Vent the test pipes at all high points ;
- Fully open the ball valve(s) ;
- Measure the L_n values several times and ascertain repeatability ;
- If the L_n values are not repeatable, repeat the procedure until repeatable values are attained (it should be possible to repeat the L_n values at 2 kHz and 4 kHz to not more than 0,5 dB).

Annex B (informative)

Alternative procedures for measurements for computer-aided test facilities

In computer-aided test facilities, the equalising filter for adjusting the differences ($L_{SN} - L_{SRN}$) as described in 8.2.2 is not needed. Its function can be replaced by corresponding numerical corrections for the octave bands with mid-frequencies from 125 Hz to 4 000 Hz determined before or during the test. Data processing according to equation (2) will then immediately give the final result (L_{ap}).

Furthermore, it is readily possible to carry out measurements of L_N and L_{SN} with available one-third octave band equipment (for example real time analyser). These measurements will be equivalent to octave band measurements if the results are recombined to octave band sound pressure levels by an energy summation prior to applying the corrections ($L_{SN} - L_{SRN}$) and the A-weighting, $k(A)_N$.

Finally, in many practical instances, only slightly different values for L_{ap} will be obtained if the corresponding corrections and the A-weighting are applied directly to the one-third octave band results of measurement. As an aid for such an evaluation, the necessary reference values for the INS in one-third octave bands are given in table B.1. They have been calculated from the reference values given in table 1 on the condition that their A-weighted sound pressure level is equal to 45 dB and that summing on an energy basis of three adjacent one-third octave band values will give the octave band reference values (to an accuracy of within 0,025 dB).

Table B.1 - Calculated one-third octave band reference values for the INS at a flow pressure of 0,3 MPa

Mid-frequencies of one-third octave band Hz	Reference one-third octave band sound pressure level dB
100	28,0
125	30,0
160	31,8
200	33,0
250	34,0
315	35,4
400	36,6
500	37,5
630	37,5
800	37,5
1 000	37,5
1 250	36,6
1 600	34,6
2 000	32,0
2 500	27,4
3 150	23,2
4 000	19,0
5 000	14,4

Annex C (normative)

Selection of samples

C.1 Definitions

For the purposes of this annex the following definition applies :

basic model : a design type (complete product) provided with one design of body and one design of each of the water controlling components.

C.2 Test samples

Three samples of each basic model to be tested are required. They shall be selected at random from stock.

C.3 Model selection

C.3.1 General principle

The same noise rating may be attributed to a number of different models of an appliance by the testing of a single basic model provided that :

- a) the water controlling components are of identical design in each model, and
- b) the internal shapes of waterways in different models are either identical or similar, and
- c) proof of a) and b) is provided in the form of dimensioned drawings and/or sectioned examples, and
- d) the basic model having acoustically the least favourable shapes is tested.

Guidance on the selection of the appropriate basic model to be tested is given in C.3.2. If neither the particular guidance nor the general principle enables a representative model to be selected, then each model shall be tested.

C.3.2 Particular guidance

C.3.2.1 Identical components [see C.3.1 a)]

C.3.2.1.1 Draw-off taps and mixing valves (see EN ISO 3822-2)

The following features shall be identical to all models :

- headwork of all types of taps and flow controls, including ceramic plates, washer plate, washer and seat ;
- mixing mechanism of mechanical and thermostatic mixing valves ;
- thermostat of thermostatic mixing valves ;
- diverter mechanism ;
- timing mechanism of hydraulically operated self-closing taps and valves ;

ISO 3822-1:1999(E)

- flow adjusters of all appliances ;
- internal shapes of body waterways.

C.3.2.1.2 In-line valves and appliances (see EN ISO 3822-3)

The following features shall be identical to all models :

- headwork, obturator and seat of stop valves, control valves, check valves and anti-backsiphonage valves ;
- flow responsive mechanism of water meters ;
- pressure sensing and control mechanism of hydraulically operated pressure reducing valves ;
- mixing mechanism and thermostat of thermostatic mixing valves ;
- flow adjusters of all appliances ;
- internal shapes of body waterways.

C.3.2.1.3 Special appliances (see EN ISO 3822-4)

For special appliances which are tested according to EN ISO 3822-2 or EN ISO 3822-3 the guidance in C.3.2.1.1 and C.3.2.1.2 respectively shall apply. In addition the following features shall be identical to all models :

- seat and shut-off mechanism of float operated valves ;
- seat, obturator and timing mechanism of flushing valves ;
- flow controlling and sensing mechanism of water heaters ;
- spray plate and function selector of shower heads and handsets ;
- seat, obturator etc. of diverters, flow controls and anti-backsiphonage valves ;
- flow adjusters of all appliances ;
- all parts of aerators (jet regulators) and ball joints ;
- internal shapes of body waterways.

C.3.2.2 Components having similar internal shape [see C.3.1 b)]

In all types of appliance the following features shall be of at least similar internal shape in all models :

- outlet spouts ;
- inlet and outlet connectors.

C.3.2.3 Acoustically unfavourable shapes [see C.3.1 d)]

The following shape details are acoustically the most unfavourable :

- narrowest cross-section and smallest radii in waterways of bodies and connectors ;
- shortest reach and smallest internal radii in outlet spouts.

C.3.3 Examples of outlet selection for a mixing valve

A mixing valve with symmetrical upper and lower outlet connections is shown in figure C.1. It is available with any of the outlets shown in figure C.2 and figure C.3. For the upper outlet, (c) of figure C.2 is selected. For the lower outlet, (a) of figure C.3 is selected. Any diverter used with outlets in figure C.3 shall be identical in all cases.

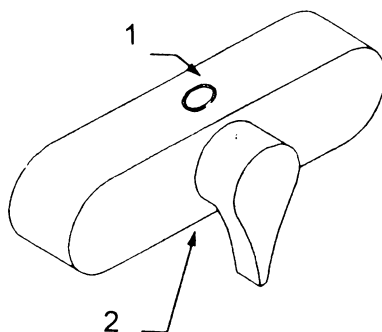

Legend

- 1 Upper outlet connection
- 2 Lower outlet connection

Figure C.1 – Mixing valve with symmetrical (identical) outlet connections

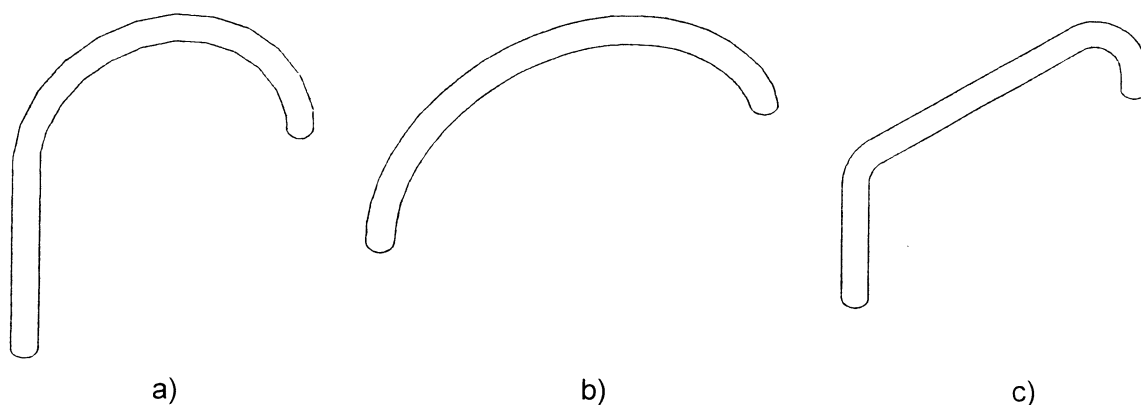

Figure C.2 – Alternative outlets used at upper connection

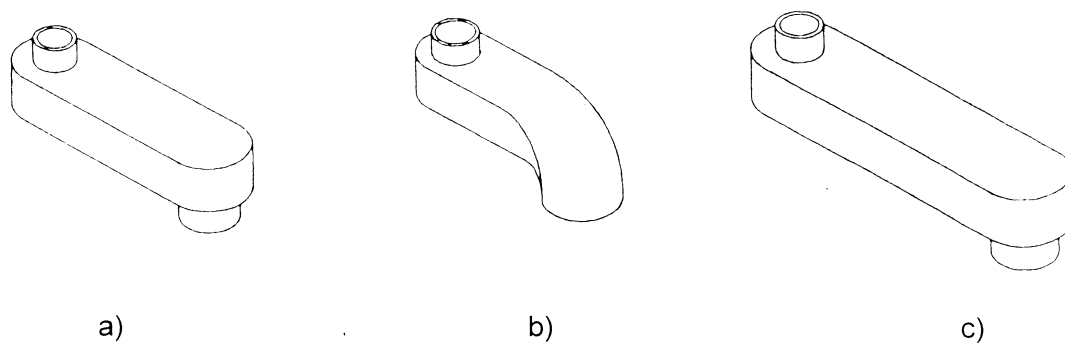

Figure C.3 – Alternative outlets used at lower connection

ICS 17.140.20; 91.140.60

Price based on 19 pages

© ISO 1999 – All rights reserved