

Second edition
2013-09-01

Corrected version
2013-11-15

**Gas cylinders — Acetylene cylinders
— Basic requirements and type testing**

*Bouteilles à gaz — Bouteilles d'acétylène — Exigences fondamentales
et essais de type*



Reference number
ISO 3807:2013(E)

© ISO 2013



COPYRIGHT PROTECTED DOCUMENT

© ISO 2013

All rights reserved. Unless otherwise specified, no part of this publication may be reproduced or utilized otherwise in any form or by any means, electronic or mechanical, including photocopying, or posting on the internet or an intranet, without prior written permission. Permission can be requested from either ISO at the address below or ISO's member body in the country of the requester.

ISO copyright office
Case postale 56 • CH-1211 Geneva 20
Tel. + 41 22 749 01 11
Fax + 41 22 749 09 47
E-mail copyright@iso.org
Web www.iso.org

Published in Switzerland

Contents

	Page
Foreword	iv
Introduction	v
1 Scope	1
2 Normative references	1
3 Terms and definitions	1
4 Basic requirements	3
4.1 Cylinder shell	3
4.2 Porous material	3
4.3 Solvent content and acetylene content	4
4.4 Working pressure	4
4.5 Cylinder identification	4
4.6 Fusible plugs	4
4.7 Accessories	5
5 Type approval	5
5.1 General requirements	5
5.2 Request for approval	5
5.3 Cylinder type tests	6
5.4 Information to be given in the type approval document	7
6 Manufacturing of the porous material	8
7 Solvent-free acetylene cylinders	8
Annex A (normative) Determination of the porosity of the porous material	9
Annex B (normative) Determination of the compressive strength of monolithic porous materials	10
Annex C (normative) Calculation of the working pressure	11
Annex D (normative) Verification that development of hydraulic pressure is prevented	12
Annex E (normative) Backfire test	14
Annex F (normative) Fire test	18
Annex G (normative) Testing of the integrity of the porous material in the area of joggle welds	21
Annex H (normative) Test procedures for fusible plugs used in acetylene cylinders	22
Annex I (normative) Inspection procedures for the manufacture of acetylene cylinders	24
Annex J (informative) Explanation and examples for the calculation method according to D.3	26
Bibliography	28

Foreword

ISO (the International Organization for Standardization) is a worldwide federation of national standards bodies (ISO member bodies). The work of preparing International Standards is normally carried out through ISO technical committees. Each member body interested in a subject for which a technical committee has been established has the right to be represented on that committee. International organizations, governmental and non-governmental, in liaison with ISO, also take part in the work. ISO collaborates closely with the International Electrotechnical Commission (IEC) on all matters of electrotechnical standardization.

International Standards are drafted in accordance with the rules given in the ISO/IEC Directives, Part 2.

The main task of technical committees is to prepare International Standards. Draft International Standards adopted by the technical committees are circulated to the member bodies for voting. Publication as an International Standard requires approval by at least 75 % of the member bodies casting a vote.

Attention is drawn to the possibility that some of the elements of this document may be the subject of patent rights. ISO shall not be held responsible for identifying any or all such patent rights.

ISO 3807 was prepared by Technical Committee ISO/TC 58, *Gas cylinders*.

This second edition of ISO 3807 cancels and replaces the first edition of ISO 3807-1:2000 and the first edition of ISO 3807-2:2000. The main technical modifications are the following:

- a) ISO 3807-1 and ISO 3807-2 were revised taking into account EN 1800 and the according requirements were merged into one standard (ISO 3807).
- b) A test for the compressive strength of the porous material was added.
- c) A calculation method as an alternative to the elevated temperature test was added.
- d) The impact stability test was removed.
- e) The procedure for establishing permissible acetylene/solvent concentrations for bundles was removed and is now included in ISO 13088.

This corrected version of ISO 3807:2013 corrects Formula (I.1).

Introduction

There are two types of acetylene cylinders operated in certain parts of the world:

- acetylene cylinders with a test pressure of at least 60 bar and without fusible plugs;
- acetylene cylinders with a test pressure of at least 52 bar, fitted with fusible plugs which release the gas and hence reduce the pressure if the cylinder temperature increases unintentionally.

This International Standard covers the requirements for both types of acetylene cylinders and specifies specific requirements in separate Annexes.

This International Standard is intended to be used under a variety of national regulatory regimes but has been written so that it is suitable for the application of the UN Model Regulations [\[1\]](#). Attention is drawn to requirements in the specified relevant national regulations of the country (countries) where the cylinders are intended to be used that might override the requirements given in this International Standard.

In International Standards, weight is equivalent to a force, expressed in Newton. However, in common parlance (as used in terms defined in this International Standard), the word “weight” continues to be used to mean “mass”, even though this practice is deprecated (ISO 80000-4).

In this International Standard the unit bar is used, due to its universal use in the field of technical gases. It should, however, be noted that bar is not an SI unit, and that the according SI unit for pressure is Pa.

Pressure values given in this International Standard are given as gauge pressure (pressure exceeding atmospheric pressure) unless noted otherwise.

11/29/2013 00:25:35 MST

Gas cylinders — Acetylene cylinders — Basic requirements and type testing

1 Scope

This International Standard specifies the basic and type testing requirements for acetylene cylinders with and without fusible plugs with a maximum nominal water capacity of 150 l and requirements regarding production/batch test procedures for manufacturing of acetylene cylinders with porous material.

It does not include details of the design of the cylinder shell; these are specified, for example, in ISO 9809-1, ISO 9809-3, ISO 4706 and ISO 7866.

NOTE The limitation to 150 l is derived from the definition for cylinder in the UN Model Regulations. However, in practice acetylene cylinders in general have lower water capacities than 150 l.

2 Normative references

The following referenced documents are indispensable for the application of this document. For dated references, only the edition cited applies. For undated references, the latest edition of the referenced document (including any amendments) applies.

ISO 10297, *Gas cylinders — Cylinder valves — Specification and type testing*

3 Terms and definitions

For the purposes of this document, the following terms and definitions apply.

3.1

acetylene cylinder

cylinder, manufactured and suitable for the transport of acetylene, containing a *porous material* (3.6) and *solvent* (3.9) (where applicable) for acetylene with a valve and other accessories affixed to the cylinder

Note 1 to entry: For solvent-free acetylene cylinders, see [Clause 7](#).

Note 2 to entry: When there is no risk of ambiguity, the word “cylinder” is used.

3.2

cylinder shell

<acetylene cylinders> empty cylinder, manufactured and suitable for receiving and containing a *porous material* (3.6) for use as part of an *acetylene cylinder* (3.1)

3.3

fusible plug

non-reclosing pressure relief device designed to function by the yielding or melting of a plug of fusible material at a predetermined temperature

3.4

manufacturer

<acetylene cylinders> company responsible for filling the *cylinder shell* (3.2) with *porous material* (3.6) and which generally prepares it for the first charge of acetylene

3.5

maximum acetylene content

<acetylene cylinders> specified maximum weight of acetylene including *saturation acetylene* (3.8) in an *acetylene cylinder* (3.1)

Note 1 to entry: When using tare S, the maximum acetylene charge may be used. The maximum acetylene charge is the maximum acetylene content minus the saturation acetylene.

3.6

porous material

<acetylene cylinders> single or multiple component material introduced to or formed in the *cylinder shell* (3.2), that, due its porosity, allows the absorption of a solvent/acetylene solution

Note 1 to entry: The porous material can be either monolithic, consisting of a solid product typically obtained by reacting materials or by materials connected together with a binder, or non-monolithic, consisting of granular, fibrous or similar materials without addition of a binder.

3.7

porosity

<acetylene cylinders> ratio of the total volume [*water capacity* (3.13)] of the *cylinder shell* (3.2) minus the volume of the solid fraction (portion) of the *porous material* (3.6), to the *water capacity* (3.13) of the *cylinder shell* (3.2)

Note 1 to entry: For the determination of the porosity see [Annex A](#) or [Annex I](#).

3.8

saturation acetylene

<acetylene cylinders> acetylene dissolved in the *solvent* (3.9) in the *acetylene cylinder* (3.1) at atmospheric pressure (1,013 bar) and at a temperature of 15 °C

3.9

solvent

<acetylene cylinders> liquid that is absorbed by the *porous material* (3.6) and is capable of dissolving and releasing acetylene

Note 1 to entry: The following abbreviations are used: "A" for acetone and "DMF" for dimethylformamide.

3.10

specified solvent content

<acetylene cylinders> weight of *solvent* (3.9) that the *acetylene cylinder* (3.1) shall contain that is established during prototype testing

3.11

tare

<acetylene cylinders> reference weight of the *acetylene cylinder* (3.1) including the *specified solvent content* (3.10)

Note 1 to entry: The tare is further specified in accordance with [3.11.1](#) to [3.11.3](#).

Note 2 to entry: For acetylene cylinders with solvent, the tare is expressed by indicating either tare S or both, tare A and tare S. For solvent-free acetylene cylinders, the tare is expressed by indicating tare F. For the tare used for acetylene cylinders in bundles, see ISO 13088.

3.11.1

tare A

<acetylene cylinders> sum of the weights of the empty *cylinder shell* (3.2), the *porous material* (3.6), the *specified solvent content* (3.10), the valve, the coating and the valve guard, where applicable, and all other parts which are permanently attached to the *acetylene cylinder* (3.1) when it is presented to be filled

Note 1 to entry: Generally valve guards are included in the tare and are considered to be permanently attached (and are not removed when the cylinder is filled). This, however, might not always be the case.

3.11.2**tare S**

<acetylene cylinders> *tare A* (3.11.1) plus the weight of the *saturation acetylene* (3.8)

3.11.3**tare F**

<acetylene cylinders> *tare A* (3.11.1) minus the *specified solvent content* (3.10)

3.12**top clearance**

<acetylene cylinders> gap between the inside of the cylinder shoulder and the monolithic *porous material* (3.6)

3.13**water capacity**

<acetylene cylinders> actual capacity of the *cylinder shell* (3.2) measured by filling the *cylinder shell* (3.2) with water

Note 1 to entry: The cylinder shell is defined as being empty of any porous material; see 3.2.

3.14**working pressure**

<acetylene cylinders> settled pressure at a uniform reference temperature of 15 °C in an *acetylene cylinder* (3.1) containing the *specified solvent content* (3.10) and the *maximum acetylene content* (3.5)

Note 1 to entry: For the determination of the working pressure see [Annex C](#).

4 Basic requirements**4.1 Cylinder shell**

The acetylene cylinder shell shall conform to the requirements of the relevant International Standard for design and construction of the cylinders, e.g.

- for seamless steel, ISO 9809-1, ISO 9809-3;
- for welded steel, ISO 4706;
- for seamless aluminium alloy, ISO 7866.

NOTE Other standards for the design and construction of cylinders are in preparation and appropriate standards should be conformed to when published.

The minimum test pressure for acetylene cylinders without fusible plugs shall be 60 bar.

The minimum test pressure for acetylene cylinders with fusible plugs shall be 52 bar.

4.2 Porous material

The porous material shall be compatible with the cylinder shell, the solvent and acetylene and shall not form dangerous or harmful products with these. For common porous materials consisting of inert materials (e.g. calcium silicate hydrate), this is generally the case.

The maximum specified porosity shall not exceed the minimum specified porosity by more than 3 % when determined in accordance with [Annex A](#).

$$P_{\max} - P_{\min} \leq 3 \%$$

(1)

where P is the porosity of the porous material, in %.

The compressive strength as determined in accordance with [Annex B](#) shall be at least 2 MPa (20 bar).

For safety reasons, the porous material shall be able to prevent the propagation of an acetylene decomposition within the cylinder and shall be of such quality that it enables the acetylene cylinder to meet the requirements of [Annex D](#) and [Annex E](#).

Acetylene cylinders equipped with fusible plugs shall pass the fire test described in [Annex F](#) in addition.

Where cylinder shells with joggle welds are used, it shall be verified that the welds do not damage the porous material in accordance with [Annex G](#).

To ensure the quality and uniform distribution of the porous material in the acetylene cylinder and the quality and amount of the solvent, test procedures shall be established by the manufacturer of the porous material in accordance with [Annex I](#).

4.3 Solvent content and acetylene content

The solvent shall be compatible with the cylinder shell. For the commonly used solvents acetone and DMF this is generally the case.

The specified solvent content and the maximum acetylene content for an acetylene cylinder shall be such that the cylinder will meet the requirements specified in [Annex D](#) and [Annex E](#).

The specified solvent content and the maximum acetylene content for an acetylene cylinder equipped with fusible plugs shall be such that the cylinder will meet the requirements specified in [Annex F](#) in addition.

4.4 Working pressure

When the cylinder has been filled with the specified solvent content and the maximum acetylene content, and the pressure has reached equilibrium at a uniform reference temperature of 15 °C, the gauge pressure in the cylinder shall not exceed the working pressure as calculated in accordance with [Annex C](#).

4.5 Cylinder identification

For the stamp marking of acetylene cylinders see the relevant regulations. Further information can be found in ISO 13769.

In addition, solvent free acetylene cylinders shall bear the words “solvent-free” painted in a clear and visible manner.

NOTE Attention is drawn to requirements for marking in relevant regulations that might override the requirements given in this International Standard.

4.6 Fusible plugs

For acetylene cylinders equipped with fusible plugs, the fusible plugs shall be sized and selected as to location and quantity so that the fusible plug(s) are capable of preventing bursting of the normally filled cylinder when subjected to a fire test in accordance with [Annex F](#).

The fusible plug shall utilize a fusible alloy having a yield temperature between 98 °C and 110 °C. The yield temperature is the temperature at which the fusible alloy becomes sufficiently soft to extrude from its holder to permit discharge of acetylene.

The fusible alloy may be installed in a threaded steel or brass plug. The threaded plug shall be fitted into a boss or pad, preferably on the cylinder top or in the cylinder valve. Bottom plugs are not permitted for cylinders used in bundles.

The fusible plugs shall be sample tested for yield temperature and for resistance to extrusion and leakage as a quality control procedure during manufacture and prior to installation into the cylinder in accordance with [Annex H](#).

4.7 Accessories

Valves for use with acetylene cylinders shall conform to the requirements of ISO 10297. Other accessories should conform to the requirements of appropriate International Standards, where available, e.g. valve guards and caps according to ISO 11117.

5 Type approval

5.1 General requirements

Representative cylinders, selected according to 5.3.1, by or on behalf of the approving body, shall successfully withstand the type tests as required in 5.3.2 prior to type approval being granted to the manufacturer of the porous material.

5.2 Request for approval

5.2.1 Range of an approval

A request for approval of acetylene cylinders may cover a range of different cylinder water capacities provided that:

- a) the cylinder shells are made from the same type of material (steel or aluminium alloy);
- b) the construction of the cylinder shells is similar (either seamless cylinders or cylinders with circumferential joggle welds or cylinders with butt welds only);
- c) the nominal outside diameter of the cylinders falls within the range of either:
 - ≤ 270 mm, or
 - > 270 mm;
- d) the cylinders contain the same porous material from the same factory and the same solvent;
- e) the specified solvent content per litre water capacity of the cylinder shell is the same;
- f) the maximum acetylene content per litre water capacity of the cylinder shell is the same.

NOTE The maximum acetylene content per litre water capacity may be lower than the value approved, provided the solvent content is not changed.

5.2.2 Information to be supplied

Each request for approval shall include the following information:

- a) General information, including the following information:
 - identification (trade name) of the porous material to be stamped on the cylinder;
 - name of the manufacturer and place of production of the porous material.
- b) Information on the different types of acetylene cylinders which form the subject of the request for approval and which includes, for each cylinder water capacity, the following information:
 - nominal (minimum guaranteed) water capacity in litres;
 - test pressure of the cylinder shell in bar;
 - working pressure at 15 °C in bar;
 - solvent to be used;

ISO 3807:2013(E)

- specified solvent content in kilograms per litre cylinder water capacity;
 - maximum acetylene content in kilograms per litre cylinder water capacity;
 - number and location of the fusible plugs, if applicable.
- c) A description of the porous material as it exists in the cylinder, which gives sufficient information concerning production process and quality control procedures (see [Annex I](#)). The description shall include the following:
- maximum top clearance, which shall be consistent with periodic inspection rejection criteria;
 - core hole size and packing material, where applicable.
- d) A report on the porosity determinations carried out by, or on behalf of, the manufacturer according to the method given in [Annex A](#) and the nominal porosity and tolerance within which the porous material is to be manufactured.
- e) A report on the compressive strength determinations carried out by, or on behalf of the manufacturer according to the method given in [Annex B](#).
- f) A report on the testing of the integrity of the porous material in the area of joggle welds carried out by or on behalf of the manufacturer in accordance with [Annex G](#), if applicable.

5.2.3 Declaration of the manufacturer

The request for approval shall be accompanied by a declaration from the manufacturer stating that, provided type approval is granted, the production of the porous material will be in accordance with the information given in the request for approval as listed in [5.2.2](#).

5.3 Cylinder type tests

5.3.1 General requirements

The manufacturer shall prepare a minimum of 50 cylinders representative of that cylinder type (e.g. with regard to top clearance) per cylinder water capacity to be tested.

An adequate number of these cylinders, including spare cylinders selected by or on behalf of the approving body, shall be made available for type testing. These cylinders shall be complete with porous material and valve and other accessories, if applicable, but without solvent and acetylene, unless otherwise specified by the approving body.

5.3.2 Prototype tests

5.3.2.1 For a single cylinder water capacity the following prototype tests shall be carried out and successfully passed:

- a) two cylinders shall be subjected to the porosity test in accordance with [Annex A](#);
- b) two cylinders shall be subjected to the compressive strength test in accordance with [Annex B](#);
- c) two cylinders shall be subjected to the elevated temperature test in accordance with [D.2](#) or the calculation method is applied in accordance with [D.3](#);
- d) three cylinders shall be subjected to the backfire test in accordance with [Annex E](#);
- e) for cylinders equipped with fusible plugs three cylinders shall be subjected to the fire test in accordance with [Annex F](#) in addition;
- f) if the cylinder shell has joggle welds, three cylinders shall be subjected to the test of the integrity of the porous material in the area of joggle welds in accordance with [Annex G](#).

5.3.2.2 For a range of cylinders of different water capacities as defined in [5.2.1](#) the following type tests shall be carried out and successfully passed:

- a) two cylinders of the largest and two cylinders of the smallest water capacity shall be subjected to the porosity test in accordance with [Annex A](#);
- b) two cylinders shall be subjected to the compressive strength test in accordance with [Annex B](#);
- c) two cylinders of the largest water capacity shall be subjected to the elevated temperature test in accordance with [D.2](#) or the calculation method is applied in accordance with [D.3](#);
- d) three cylinders of the largest and three cylinders of the smallest water capacity shall be subjected to the backfire test in accordance with [Annex E](#);
- e) for cylinders equipped with fusible plugs three cylinders of each nominal diameter shall be subjected to the fire test in accordance with [Annex F](#) in addition;
- f) if the cylinder shell has joggle welds, three cylinders of the largest and three cylinders of the smallest water capacity shall be subjected to the test of the integrity of the porous material in the area of joggle welds in accordance with [Annex G](#).

5.3.3 Tests for extension of the approval

For cylinders which are identical to cylinders that have already passed prototype testing with regard to [5.2.1 c](#)), d), e) and f) and differ only with regard to the type of material of the cylinder shell (see [5.2.1 a](#)) and/or the construction of the cylinder shell (see [5.2.1 b](#)), a reduced test programme may be performed in order to extend the approval as follows.

Three cylinders of the largest and three cylinders of the smallest water capacity shall be subjected to the drop procedure as specified in [E.2](#). They shall then be sectioned longitudinally and inspected for damage to the porous material (e.g. excessive clearance, cracks, disintegration). If the porous material is undamaged, no further tests according to [Annex E](#) are required. If the porous material is damaged, a complete backfire test (see [Annex E](#)) on a further three cylinders of those water capacities that did not pass the drop test shall be carried out.

NOTE 1 Welded cylinders previously approved with joggle welds do not need a test for extension of the approval for other welded or seamless cylinders.

NOTE 2 The elevated temperature test (see [Annex D](#)) need not be carried out.

NOTE 3 The reduced test programme is not applicable to cylinders with non-monolithic porous materials.

5.4 Information to be given in the type approval document

The type approval is valid for a certain range/scope (see [5.2.1](#) and [5.3.2.2](#)). Therefore, the type approval document shall indicate at least the following information:

- a) identification (trade name) of the porous material to be stamped onto the cylinder as provided by the manufacturer;
- b) name of the manufacturer and place of production of the porous material;
- c) type of cylinders and their water capacity that may be filled with the porous material (e.g. by listing the respective cylinder standards and water capacities or the respective range of water capacities);
- d) cylinder construction (seamless or with butt welds or joggle welds);
- e) nominal outside diameter range of the cylinders (≤ 270 mm or > 270 mm);
- f) test pressure of the cylinder shell;
- g) nominal porosity and tolerance of the porous material;

- h) working pressure at 15 °C;
- i) type of solvent and specified solvent content;
- j) maximum acetylene content for solvent-containing acetylene cylinders;
- k) maximum acetylene content for solvent-free acetylene cylinders, if applicable;
- l) for cylinders equipped with fusible plugs, number and location of the fusible plugs;
- m) maximum permissible top clearance between porous material and the inside of the cylinder shoulder.

6 Manufacturing of the porous material

The factory which is manufacturing and filling the porous material into the cylinder shell shall be audited by, or on behalf of, the approving body. The audit shall verify that the manufacturer has established production/batch test procedures for manufacturing of the porous material in order to guarantee conformity of the manufactured acetylene cylinders with the cylinders selected for type testing in accordance with 5.3.1. The minimum requirements are given in Annex I.

7 Solvent-free acetylene cylinders

Solvent-free acetylene cylinders are not specifically type tested. In order to be approved for use as solvent-free acetylene cylinders, an approval for acetylene cylinders with solvent is necessary. The filling conditions for solvent-free acetylene cylinders are derived based on the relevant data for solvent containing acetylene cylinders, as described below, and are also indicated in the approval.

The maximum acetylene content and working pressure are derived as follows:

- a) The working pressure shall not exceed the working pressure for the cylinders with solvent.
- b) The maximum acetylene content is calculated based on the density of acetylene, the working pressure and the available volume (volume which considers the porosity of the porous material).

$$m_A = \frac{p_w + 1,013 \text{ bar}}{1,013 \text{ bar}} \frac{\rho_A}{1\,000} \frac{P}{100\%} \quad (2)$$

where

m_A is the maximum acetylene content of the solvent free cylinder, in kg/l;

p_w is the working pressure, in bar;

ρ_A is the density of acetylene at 15 °C, $\rho_A = 1,109 \text{ kg/m}^3$ (see Reference [9]);

P is the nominal porosity of the porous material, in %.

The maximum acetylene content of solvent-free cylinders shall not exceed 1/10 of that of the cylinders with solvent.

Annex A (normative)

Determination of the porosity of the porous material

A.1 Procedure

This test may be carried out by or on behalf of the manufacturer of the porous material. It shall be carried out using finished cylinders containing porous material that have not previously been filled with solvent or acetylene.

- a) A cylinder filled only with the porous material is fitted with a valve and weighed. It is evacuated so that after standing for 12 h, with the valve closed, the pressure is less than 27 mbar absolute. It is then filled with acetone under a pressure not exceeding the pressure recommended by the manufacturer in order not to damage the porous material. When the solvent no longer penetrates, the valve is closed and the cylinder is weighed.
- b) The cylinder is again evacuated for at least 15 min and further acetone is added. This cycle of operations is repeated until all air is expelled from the cylinder and a constant weight obtained.
- c) The cylinder is then placed in a room where the temperature is constant, the valve being left open and connected to a vessel containing acetone under a small liquid head, for at least 24 h.
- d) The valve is then closed, the acetone container disconnected and the cylinder weighed.
- e) The difference between the final weight of the cylinder and that of the cylinder before filling it with acetone represents the weight of acetone introduced.

A.2 Calculation

The nominal porosity P of the porous material is calculated by the following formula:

$$P = \frac{m}{V \times \rho} \times 100\% \quad (\text{A.1})$$

where

- P is the nominal porosity of the porous material, in %;
- m is the weight of acetone, in kg;
- V is the actual water capacity of the cylinder shell without porous material, in l;
- ρ is the density of acetone at the temperature as in A.1 c), in kg/l.

A.3 Criteria

For passing the porosity test the porosity of both cylinders shall lie within the range specified by the manufacturer. The range shall be not more than 3 %.

Annex B (normative)

Determination of the compressive strength of monolithic porous materials

B.1 Procedure

This test may be carried out by or on behalf of the manufacturer of the porous material. It shall be carried out using finished cylinders containing porous material that have not previously been filled with solvent or acetylene.

The cylinders are cut open and three samples of the porous material are taken; one from the upper, one from the middle and one from the lower part of the cylinder (for cylinders with a water capacity of ≤ 5 l two samples are taken, one from the upper and one from the lower part). The height of the samples shall be between 50 mm and 100 mm. The sample may be either cubic or covering the whole cross-section of the cylinder. The samples are dried to constant weight (with a maximum difference of 2 %) in a drying oven at a temperature of 110 °C to 150 °C.

The compressive strength is tested by increasing the load continuously over the complete cross-section of the sample of the porous material until the sample crushes. The average increase of the pressure shall be 0,1 MPa/s to 1 MPa/s (1 bar/s to 10 bar/s). The maximum load is determined.

B.2 Calculation

The compressive strength of the porous material is calculated by the following formula:

$$\sigma = \frac{F}{A} \quad (\text{B.1})$$

where

σ is the compressive strength of the porous material, in N/mm² (= MPa);

F is the maximum load applied, in N;

A is the cross-section of the sample, in mm².

B.3 Criteria

For passing the compressive strength test, the compressive strength of all samples shall be equal to or more than 2 MPa (20 bar).

Annex C (normative)

Calculation of the working pressure

The working pressure shall be calculated by the following formula (rounded up to the next integer).

$$P_w = a_1 \times \frac{\frac{m_A}{m_S} + a_2}{\frac{m_A}{m_S} + a_3} + 1,7 \quad (\text{C.1})$$

where

P_w is the working pressure, in bar;

m_A is the maximum acetylene content, in kg;

m_S is the specified solvent content, in kg;

a_1, a_2, a_3 are constants with values as given in [Table C.1](#).

Table C.1 — Pressure equation constants^a

Constant	Solvent	
	Acetone	DMF
a_1	59,853	-50,671
a_2	-0,020 2	0,095 8
a_3	1,524 7	-2,525 3

^a The constants are taken from MILLER (see Reference [9]).

Annex D (normative)

Verification that development of hydraulic pressure is prevented

D.1 General

This test shall ensure that no hydraulic pressure develops during the operation of acetylene cylinders. This shall be ensured by performing the elevated temperature test according to [D.2](#) or by making use of the calculation method according to [D.3](#).

D.2 Elevated temperature test

D.2.1 Procedure

This test shall be carried out using finished cylinders containing porous material which are filled with the specified solvent content and with the maximum acetylene content as prescribed by the manufacturer, plus an overcharge of 5 % acetylene.

Each cylinder shall be placed in a heated water bath, the temperature of which is maintained at (65 ± 2) °C. The pressure of the cylinder shall be recorded continuously. The test shall be continued until the pressure in the cylinder becomes constant. If the pressure curve shows that hydraulic pressure has developed or if the test pressure of the cylinder is exceeded, the test shall be stopped.

D.2.2 Criteria

If during this test the pressure curve indicates that hydraulic pressure has developed in the cylinder, or if the maximum pressure in the cylinder exceeds the cylinder test pressure, the cylinder has failed.

For passing the type test, both cylinders shall pass the elevated temperature test.

D.3 Calculation method

D.3.1 General

The calculation method is applicable to cylinders with acetone as solvent only.

D.3.2 Calculation

The free volume in the acetylene cylinder with the specified solvent content and the maximum acetylene content plus an overcharge of 5 % acetylene at a temperature of 65 °C is calculated by the following formula.

$$V_{F65} = \frac{P}{100} m_S \times 1,359 \times \left(1,686 \times \frac{m_{A,105\%}}{m_S} + 0,981 \right) \quad (D.1)$$

where

V_{F65} is the free volume in the acetylene cylinder at 65 °C per litre cylinder water capacity, in l/l;

P is the nominal porosity of the porous material as established based on [Annex A](#), in %;

$m_{A,105\%}$ is the maximum acetylene content plus an overcharge of 5 % per litre cylinder water capacity, in kg/l;

m_S is the specified solvent content per litre cylinder water capacity, in kg/l.

NOTE The “volume” in Formula D.1 is actually dimensionless (in l/l) because it is related to 1 litre cylinder water capacity.

An explanation of how the formula for the calculation method is derived is given in [Annex J](#). It also contains two examples for the application of the calculation method.

D.3.3 Criteria

The test is passed if the calculated free volume V_{F65} is > 0 .

NOTE The free volume can be related to the cylinder by multiplying V_{F65} with the cylinder water capacity:

$$V_{F65,cylinder} = V_w \times V_{F65}$$

where

$V_{F65,cylinder}$ is the free volume in the acetylene cylinder at 65 °C, in l;

V_w is the water capacity of the empty cylinder shell, in l.

Annex E (normative)

Backfire test

E.1 General

The backfire test comprises two steps, a drop procedure according to [E.2](#) followed by the backfire procedure according to [E.3](#).

The purity of the acetylene which is used for this test shall be at least 98 %.

E.2 Drop procedure

Each cylinder shall be filled with the specified solvent content and shall be fitted with a device that will prevent loss of cylinder contents during the drop procedure.

Each cylinder shall be dropped 10 times from a height of 0,70 m on to a concrete block covered with a protective plate in an apparatus similar to that shown in [Figure E.1](#). It shall be confirmed that the friction between the cylinder and any guides is negligible.

Any subsidence or other defect of the porous material which has taken place during the drop procedure shall not be corrected before submitting the cylinders to the backfire procedure.

The top clearance shall be measured both before and after the drop procedure and recorded in the test report (for further information on determination of the top clearance see ISO 10462).

The maximum allowed top clearance indicated in the approval shall not exceed the top clearance of the cylinders measured before the drop procedure. However, if the measured top clearance was below 2 mm, it is permitted to indicate a maximum allowed top clearance of 2 mm in the approval.

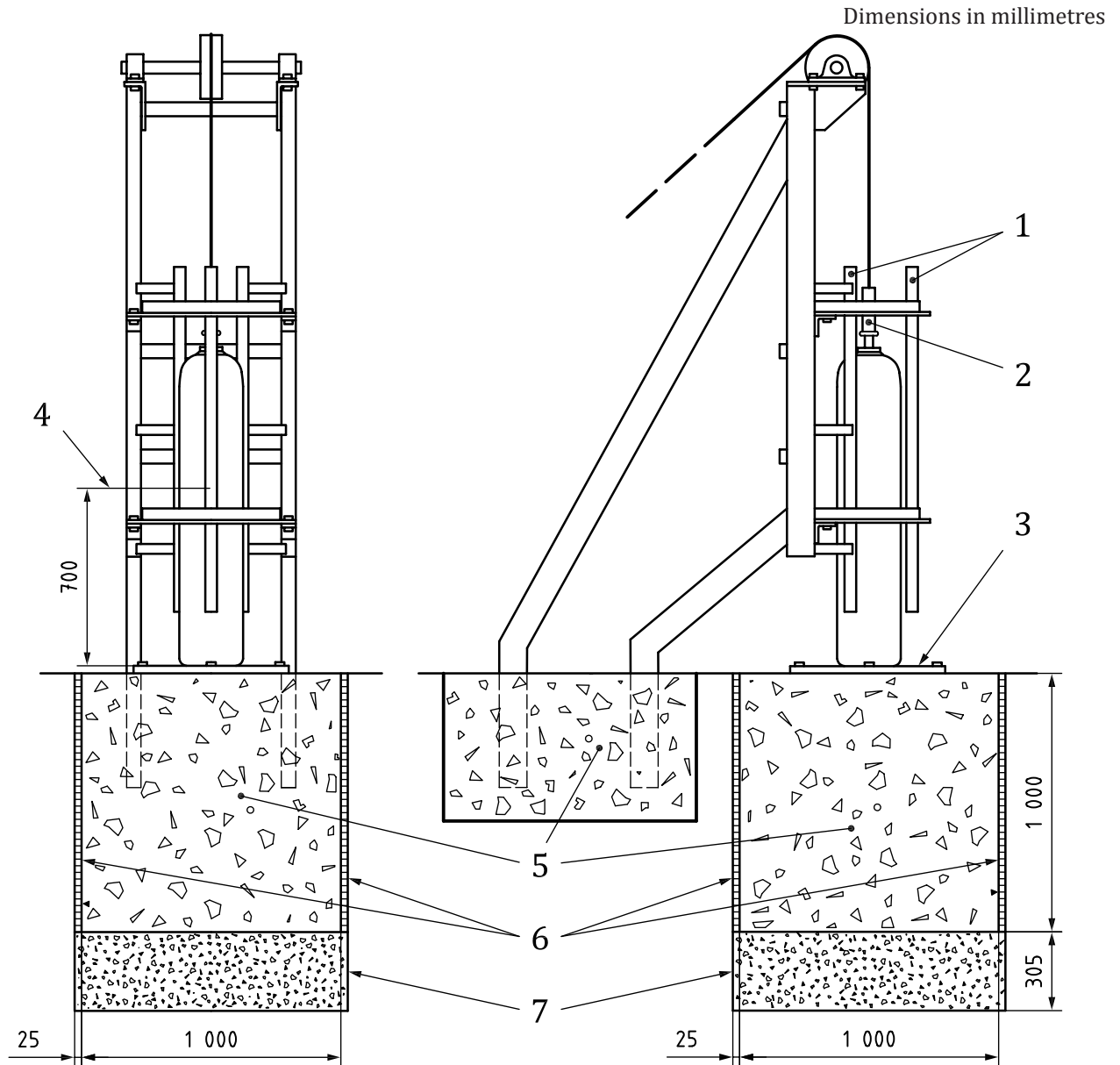

Key

- 1 guides
- 2 quick release system
- 3 protective plate^a
- 4 height of travel
- 5 concrete^b
- 6 sound proofing (optional)
- 7 sand

^a The protective plate shall consist of 25 mm thick sheet made from material with a Brinell hardness of approx. 48 HB (10 mm ball, 300 kg load)

^b Recommended concrete grade for the foundation is C25/30 in accordance with ISO 3893:1977. The concrete shall be cast in one piece. It is important that the surface on which the protective plate is placed be smooth and horizontal

Figure E.1 — Typical apparatus for the drop procedure

E.3 Backfire procedure

E.3.1 Explosion tube

After having undergone the drop procedure as described in [E.2](#), the cylinder shall be fitted with an explosion tube directly connected to the cylinder similar to that shown in [Figure E.2](#). The explosion tube shall contain a means of ignition, consisting of a firing device with a suitable wire. During the backfire test it shall be possible to measure the cylinder pressure.

NOTE The surface temperature of the cylinder can also be measured during the test for information (e.g. on the top and on the upper third part of the cylinder).

E.3.2 Acetylene content

The cylinders fitted with the appropriate equipment shall be filled with acetylene to the maximum acetylene content proposed by the manufacturer plus an overcharge of 5 %, taking all necessary steps to purge the cylinder of non-soluble gases as far as is practicable.

E.3.3 Test sequence

After filling, each cylinder shall be:

- a) stored horizontally for at least 24 h at a minimum temperature of 15 °C;
- b) placed vertically in a water bath, maintained at a temperature of 35 °C for at least 3 h, except for cylinders with a nominal water capacity ≤ 10 l for which the heating time shall be at least 1,5 h. The pressure reached shall amount to at least 20 bar;
- c) placed vertically in the firing test location;
- d) fired by igniting the firing device before the pressure inside the cylinder has fallen to a value not more than 5 % below the maximum pressure attained in the cylinder during its heating, as described in b) above.

E.3.4 Criteria

After the backfire procedure it shall be verified that the required energy has been provided to initiate the acetylene decomposition in the explosion tube (e.g. by inspection of the wire after completion of the test to ensure that it has fused).

The cylinder has failed the test if:

- it bursts;
- there is a deformation of the cylinder shell of more than 10 % of the external diameter of the cylinder shell;
- there is any release of gas within 24 h of the backfire other than through the fusible plug.

If the pressure after 24 h in any one of the tested cylinders is higher than 30 bar when the cylinders are in an ambient temperature of 15 °C, another three cylinders shall be subjected to the complete backfire test.

NOTE In case the ambient temperature is not 15 °C, the pressure in the cylinder at 15 °C can be calculated based on the pressure in the cylinder measured at another ambient temperature.

For passing the backfire test all tested cylinders shall pass the backfire test.

Dimensions in millimetres

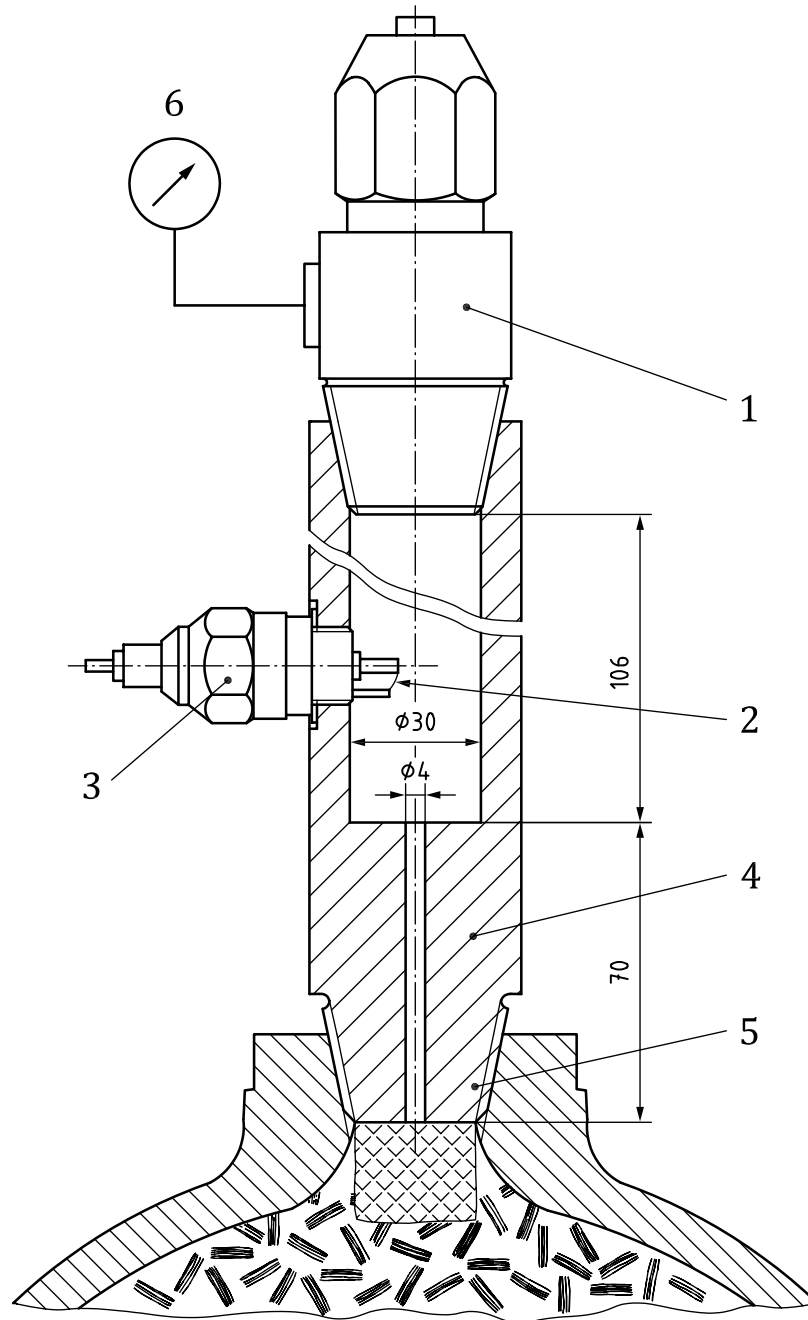

Key

- 1 valve enabling the test cylinder to be filled with acetylene
- 2 ignition source
- 3 firing device
- 4 explosion tube
- 5 thread form compatible to the cylinder thread
- 6 pressure transducer

Figure E.2 — Typical explosion tube for the backfire procedure

Annex F (normative)

Fire test

F.1 General

Each cylinder shall be filled with the specified solvent content and the maximum acetylene content. Each cylinder shall be held at a temperature of at least 18 °C for at least 18 h before testing. The pressure and shell temperature of the cylinder immediately prior to the test shall be recorded.

After an acetylene cylinder has been approved, this test shall be conducted again if there is any significant design change which includes:

- a) the number, size or design of fusible plugs;
- b) relocation of fusible plugs 25,4 mm (1 inch) or more from a previously tested location;
- c) for welded cylinders: change of the weight of the cylinder metal boss of 40 % or more;
- d) change in top or bottom shape, e.g. from convex to concave.

F.2 Chimney fire test method

F.2.1 Test set-up

The chimney fire test is designed to simulate a building fire and rate of temperature rise therein. [Figure F.1](#) shows a view of a chimney fire test apparatus. The cylinder stands upright on a non-combustible base within an enclosure and is not subject to direct flame impingement.

The burner shall be capable of delivering a flue gas temperature of approximately 650 °C within 5 min of start-up and maintaining that same gas flow rate for 15 min.

During the test the following shall be recorded at 30 s intervals (if not continuously):

- a) the temperature of the flue gas between the enclosure and the cylinder shell, approximately at the middle of the cylinder height;
- b) the surface temperature of the cylinder shell, approximately at the middle of the cylinder height;
- c) the pressure of the cylinder.

After ignition of the burner the flue gas temperature shall reach approximately 650 °C within 5 min. After a further 15 min the burner shall be shut off provided that the cylinder venting is complete, i.e. the cylinder pressure is approximately 0 bar. Otherwise heating shall be continued until the cylinder is completely vented. If the test is stopped before that in order to save the test equipment, the test is considered to be not passed.

WARNING — If the cylinder has not completely vented, it might burst even several hours after the burner has been shut off.

NOTE A recommended typical chimney fire test procedure is described in the CGA C-12-2007 [\[11\]](#).

Dimensions in millimetres

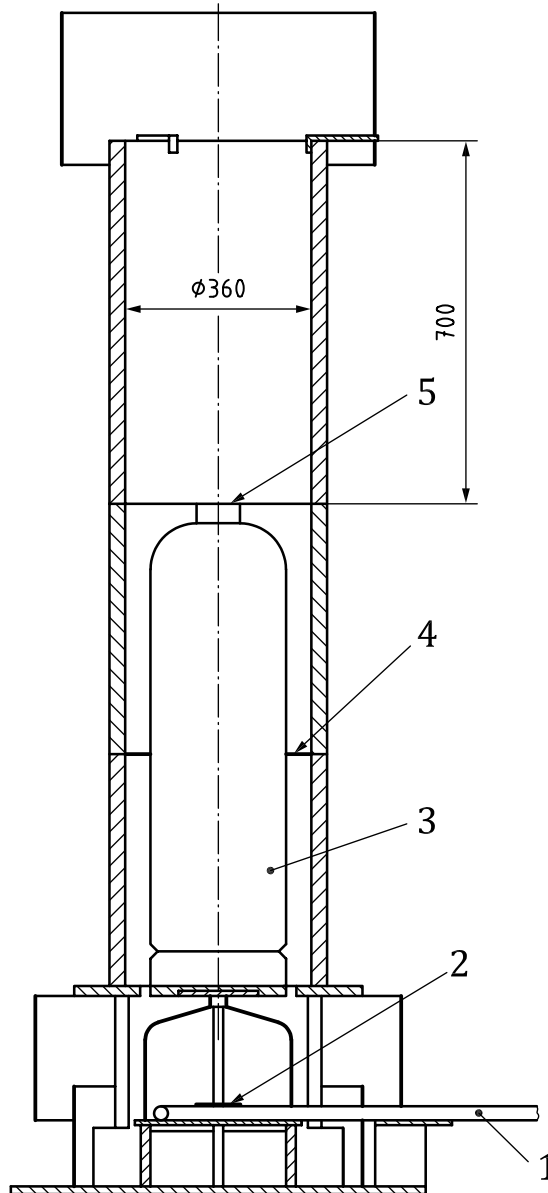
**Key**

- 1 gas pipe
- 2 gas burner
- 3 acetylene cylinder
- 4 thermocouple
- 5 pressure detection

Figure F.1 — Isometric view of a chimney fire test apparatus

A record shall be kept of the design and performance characteristics of the fire test equipment. This record shall show construction details, details of the test procedure, e.g. temperature, time, pressure, and the results of the test.

The time of the activation of the fusible plug and the time when the cylinder has completely vented shall be recorded. It can be derived from the temperature and/or pressure data recorded during the fire test.

F.2.2 Criteria

The cylinder has passed the test if:

- a) one or more fusible plugs release gas during the test; and
- b) the cylinder does not burst.

NOTE A small split due to localized overheating from an air/acetylene flame is acceptable and not cause for test failure.

For passing the fire test all tested cylinders shall pass the fire test

Annex G (normative)

Testing of the integrity of the porous material in the area of joggle welds

G.1 Procedure

This test may be carried out by or on behalf of the manufacturer of the porous material. It shall be carried out using finished cylinders containing porous material that have not previously been filled with solvent or acetylene.

Three cylinders of the largest and three cylinders of the smallest water capacity shall be subjected to the drop procedure as specified in [E.2](#). They shall then be sectioned longitudinally and inspected for voids and damage to the porous material (e.g. excessive clearance, cracks, disintegration) in the area of the cylinder welds. The porous material shall not show excessive voids or damage.

G.2 Criteria

For passing the type test, the porous material shall not show excessive voids or damage and shall not be loose in the area of the joggle welds in any of the cylinders. In general, the test should be considered to have passed if the largest diameter of the voids between the porous material and the area of the joggle welds of the cylinder are smaller than 3 mm or the maximum allowed top clearance (whichever is the smaller) and if no cracking has been caused that would loosen the porous material.

Annex H (normative)

Test procedures for fusible plugs used in acetylene cylinders

H.1 Measurement of the yield temperature of the fusible alloy

To determine the yield temperature, a test on the alloy shall be conducted as follows:

- a) Two samples of the fusible alloy are selected at random from each batch (heat) in the manufactured form; ingot, wire, etc.
- b) For a fusible alloy supplied in ingot form, two specimens, each 50 mm long by approximately 6 mm in diameter, shall be taken from each ingot for test purposes. For a fusible alloy supplied in wire form, two specimens shall be taken from each coil, each between 38 mm and 50 mm in length.
- c) Each test specimen shall be positioned horizontally on two knife edges spaced apart so that the ends of the specimen overhang the knife edges by 12 mm. The supported specimens shall be immersed in a glycerine bath positioned not closer than 6 mm to the bottom of the container.
- d) Two specimens from a given ingot or coil of wire shall be tested at the same time. The bath temperature may be raised at a maximum rate of 3 °C per min up to 5 °C below the minimum yield temperature of the alloy. After the temperature has stabilized at this level, the bath temperature shall be raised at a much slower rate, not exceeding 0,6 °C per min. Temperatures shall be measured using a suitable measuring device inserted in the bath between and closely adjacent to the specimens so that the sensor will be immersed at the same level as the specimens.
- e) The yield temperature shall be taken as that temperature at which the second of the four ends of the specimens loses its rigidity and droops, and/or drooping of the sections of the two specimens between knife edges occurs. After the temperature of the bath and the fusible metal has stabilized, yielding must occur before the maximum allowable yield temperature (110 °C) has been exceeded.

H.2 Tests of fusible plugs

H.2.1 Sampling

Two representative fusible plugs (new or reconditioned) shall be selected at random at least every day or for every 3 000 fusible plugs (if the quantity is more than 3 000 fusible plugs per day). These samples shall be subjected to the tests prescribed in [H.2.2](#) and [H.2.3](#). If the samples fail to meet the requirements of [H.2.2](#) and [H.2.3](#), all fusible plugs represented by the samples shall be rejected. If one sample fails to meet the requirements of [H.2.2](#) and [H.2.3](#), four additional samples may be selected for these tests. If any of these four additional samples fails to meet the requirements of [H.2.2](#) and [H.2.3](#), all fusible plugs represented by the samples shall be rejected.

H.2.2 Resistance to extrusion

Fusible plugs used for acetylene cylinders shall be tested to confirm the fusible alloy's resistance to extrusion and leaks as follows:

- a) The fusible plugs shall be subjected to a controlled temperature of not less than 82 °C for 24 h and an air or gas gauge pressure not less than 70 % of the test pressure of the cylinder with which the device will be used. The pressure shall be applied to the end exposed to the contents of the cylinder.

- b) To pass this test, no leakage or visible extrusion of the material shall be evident upon examination of the end exposed to atmospheric pressure.

H.2.3 Yield temperature determination

The yield temperature of fusible plugs shall be determined as follows.

- a) The plugs shall be subjected to an air or gas pressure of 0,2 bar applied to the end normally exposed to the contents of the cylinder.
- b) While subjected to this pressure, the plugs shall be immersed in a water bath or glycerine bath heated to a temperature of 95 °C maximum (3 °C below the specified minimum yield temperature) and held at that temperature for a period of at least 10 min.
- c) The bath temperature shall then be raised at a rate not exceeding 0,6 °C per min during which the pressure may be increased to up to 35 bar. When the metal weakens sufficiently to produce leakage of air or gas, the temperature of the bath shall be recorded as the yield temperature of the plugs. Yielding must occur within 10 min after the maximum allowable yield temperature of 110 °C has been reached and maintained. Yielding shall occur between 98 °C and 110 °C.
- d) As an alternative to c), after the procedure described in b), the plugs shall at once be immersed in another bath held at the maximum yield temperature of 110 °C. If air or gas leakage occurs within 10 min at that temperature, the requirements have been met.

Variation in temperature within the liquid bath in which the plug is immersed shall be kept to a minimum by stirring during the procedures described in b) and c) or d).

Annex I (normative)

Inspection procedures for the manufacture of acetylene cylinders

I.1 Inspection procedures before and during manufacturing of the porous material

The manufacturer shall establish quality control procedures, including inspection frequencies, for the manufacture of the porous material, which shall include at least:

- a) specifications for the raw materials for the porous material and the solvent used;
- b) procedures for the goods inwards inspection of raw materials;
- c) (for monolithic porous materials only) procedures for inspecting every batch of porous material in the condition in which it will be introduced into the cylinders;
- d) (for monolithic porous materials only) means and procedures for recording temperature/time curves for any heat treatment (curing, drying, etc.) performed on the batch;
- e) any additional quality-relevant requirements necessary for the type of porous material manufactured.

I.2 Inspection of acetylene cylinders after their preparation with porous material

The manufacturer shall establish quality control procedures for the initial inspection of the finished acetylene cylinders which shall include at least:

- a) Procedures for the visual inspection of the porous material. These shall be carried out for every finished acetylene cylinder and shall verify that the porous material shows:
 - no top clearance above the maximum top clearance according to [5.2.2 c\)](#) first indent;
 - no excessive cracking;
 - no excessive crumbling;
 - no voids or cavities.

NOTE For more information on the visual inspection of monolithic porous materials of acetylene cylinders see ISO 10462.

- b) Means and procedures for checking and/or recording all necessary weights and volumes stamp-marked on the cylinders; they shall be determined for every cylinder.
- c) Means and procedures, including inspection frequencies for determination of the porosity of the porous material either by a test as described in [Annex A](#) or by calculation as described in the following or by another method concurred by the approving body.

Calculation method:

$$P = \frac{\rho_t - \rho_a}{\rho_t} \times 100\% \quad (I.1)$$

where

P is the porosity of the porous material, in %;

ρ_t is the true density (material density) determined by taking dry mass samples from the cylinder after final preparation and measuring with a porosimeter, in kg/m^3 ;

ρ_a is the apparent density determined by weighing a cylinder before and after preparation, taking into account the actual water capacity, in kg/m^3 .

d) (for non-monolithic porous materials) Procedures including inspection frequencies for checking excessive settlement of the porous material (e.g. by the drop procedure according to [E.2](#)).

Annex J (informative)

Explanation and examples for the calculation method according to D.3

J.1 Derivation of the calculation method

Formula D.1 is derived as follows:

$$\begin{aligned}
 V_{F65} &= V_a - V_{AS65} \\
 &= \frac{P}{100} - V_{S65} \times E_{A65} \\
 &= \frac{P}{100} - \frac{m_S \times E_{S65}}{\rho} \times E_{A65} \\
 &= \frac{P}{100} - m_S \times 1,359 \times E_{A65}
 \end{aligned} \tag{J.1}$$

where

V_{F65} is the free volume in the acetylene cylinder at 65 °C per litre cylinder water capacity, in l/l;

V_a is the available volume in the cylinder which is not occupied by porous material and can hold solvent and acetylene per litre cylinder water capacity, in l/l;

V_{AS65} is the volume of the acetone/acetylene solution at 65 °C per litre cylinder water capacity, in l/l;

V_{S65} is the volume of the acetone at 65 °C per litre cylinder water capacity, in l/l;

E_{A65} is the expansion coefficient of the acetone/acetylene solution due to dissolving acetylene at 65 °C;

P is the nominal porosity of the porous material as established in accordance with [Annex A](#), in %;

m_S is the specified acetone content per litre cylinder water capacity, in kg/l.

E_{S65} is the expansion coefficient of acetone at 65 °C = 1,08;

ρ is the density of acetone at 15 °C, $\rho = 0,795 \text{ kg/m}^3$.

The expansion coefficient of an acetone/acetylene solution due to dissolving acetylene E_A depends on the acetylene-to-acetone ratio and the temperature. For 65 °C it is calculated by the following formula:

$$E_{A65} = 1,686 \times \frac{m_{A,105\%}}{m_S} + 0,981 \tag{J.2}$$

where $m_{A,105\%}$ is the maximum acetylene content plus an overcharge of 5 % per litre cylinder water capacity, in kg/l.

Formula J.2 is derived by linear regression of values for E_{A65} as a function of different acetylene-to-acetone ratios as shown in [Figure J.1](#). The individual values for E_{A65} are derived by extrapolating the equations in Table II.36 of Reference [9].

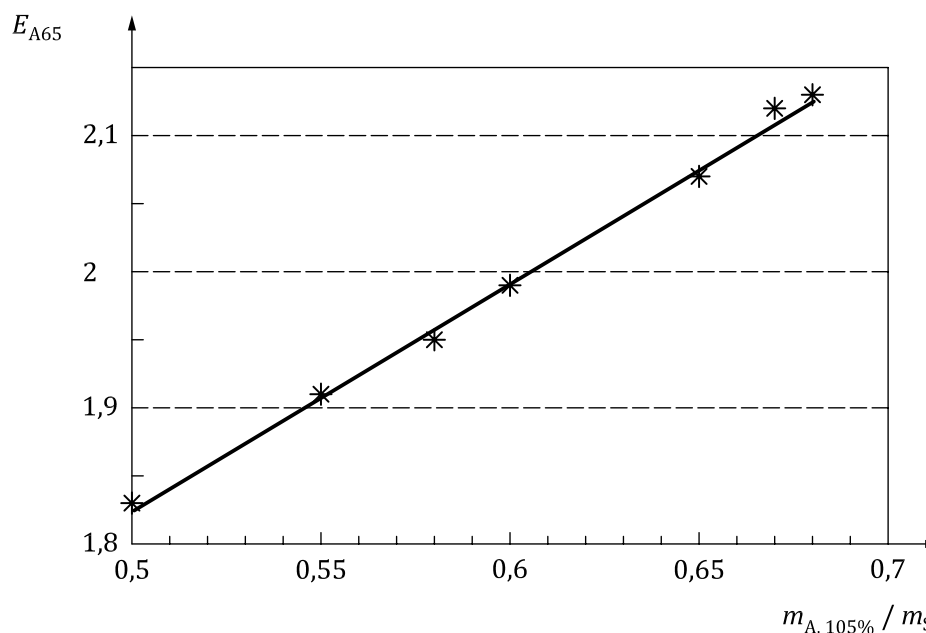
**Key**

- * values for E_{A65} which are derived by extrapolating the equations in Table II.36 of Reference [9] to 65 °C
- linear regression of the values for E_{A65} : $E_{A65} = 1,686 \times \frac{m_{A,105\%}}{m_S} + 0,981$

Figure J.1 — Expansion coefficient at 65 °C of the acetylene/acetone solution due to dissolving acetylene

J.2 Examples for the application of the calculation method

Example 1, calculation for a cylinder with

- a porosity P of 90 %,
- a specified solvent content m_S of 0,310 kg/l (corresponding to 15,5 kg/50 l) and
- a maximum acetylene content m_A of 0,200 kg/l (corresponding to 10,0 kg /50 l), therefore $m_{A,105\%}$ is 0,210 kg/l — including the 5 % overcharge:

$$V_{F65} = 90/100 - 0,310 \times 1,359 \times (1,686 \times 0,210/0,310 + 0,981) = 0,055 \text{ l/l}$$

This corresponds to a free volume $V_{F65,cylinder}$ of 0,277 l for a cylinder with a water capacity V_w of 50 l.

Example 2, calculation for a cylinder with

- a porosity P of 90 %,
- a specified solvent content m_S of 0,329 kg/l (corresponding to 13,5 kg/41 l) and
- a maximum acetylene content m_A of 0,188 kg/l (corresponding to 7,7 kg /41 l), therefore $m_{A,105\%}$ is 0,197 kg/l — including the 5 % overcharge:

$$V_{F65} = 90/100 - 0,329 \times 1,359 \times (1,686 \times 0,197/0,329 + 0,981) = 0,0100 \text{ l/l}$$

This corresponds to a free volume $V_{F65,cylinder}$ of 0,410 l for a cylinder with a water capacity V_w of 41 l.

Bibliography

- [1] *UN Recommendations on the Transport of Dangerous Goods — Model Regulations*, United Nations, Geneva, as amended
- [2] ISO 80000-4, *Quantities and units — Part 4: Mechanics*
- [3] ISO 9809-1, *Gas cylinders — Refillable seamless steel gas cylinders — Design, construction and testing — Part 1: Quenched and tempered steel cylinders with tensile strength less than 1 100 MPa*
- [4] ISO 9809-3, *Gas cylinders — Refillable seamless steel gas cylinders — Design, construction and testing — Part 3: Normalized steel cylinders*
- [5] ISO 4706, *Gas cylinders — Refillable welded steel cylinders — Test pressure 60 bar and below*
- [6] ISO 7866, *Gas cylinders — Refillable seamless aluminium alloy gas cylinders — Design, construction and testing*
- [7] ISO 13769, *Gas cylinders — Stamp marking*
- [8] ISO 11117, *Gas cylinders — Valve protection caps and valve guards — Design, construction and tests*
- [9] MILLER S. A. *ACETYLENE — Its Properties, Manufacture and Uses*. Ernest Benn, Ltd, London, **Vol. I**, 1965
- [10] ISO 3893:1977, *Concrete — Classification by compressive strength* [withdrawn]
- [11] CGA C-12-2007, *Qualification Procedure for Acetylene Cylinder Design*, Compressed Gas Association, Inc., USA
- [12] ISO 10462, *Gas cylinders — Acetylene cylinders — Periodic inspection and maintenance*
- [13] ISO 11372, *Gas cylinders — Acetylene cylinders — Filling conditions and filling inspection*
- [14] ISO 13088, *Gas cylinders — Acetylene cylinder bundles — Filling conditions and filling inspection*
- [15] IGC Doc 26/04/E, *Permissible charge / filling conditions for acetylene cylinders*, European Industrial Gases Association, Belgium

.....

.....