

INTERNATIONAL STANDARD

ISO 3795

Second edition
1989-10-15

"The American National Standards Institute (ANSI) is the primary source and official sales agent for ISO standards in the United States. ANSI was granted an exclusive license to distribute and sell ISO standards, technical reports, drafts and other priced publications within the U.S.A. Under this license agreement ISO has granted to ANSI the right to reproduce ISO standards and drafts within the territories of the United States"

Road vehicles, and tractors and machinery for agriculture and forestry — Determination of burning behaviour of interior materials

*Véhicules routiers et tracteurs et matériels agricoles et forestiers — Détermination
des caractéristiques de combustion des matériaux intérieurs*

ATTENTION CUSTOMERS

Copies of international standards, catalogs, and handbooks (ISO and IEC), as well as all foreign standards from ISO member body countries (DIN, JISC, BSI, AFNOR, etc.), are available in the U.S. from ANSI, 11 West 42nd Street, New York, NY 10036.

Tel. (212) 642-4900, Fax. (212) 302-1286.



Reference number
ISO 3795 : 1989 (E)

Foreword

ISO (the International Organization for Standardization) is a worldwide federation of national standards bodies (ISO member bodies). The work of preparing International Standards is normally carried out through ISO technical committees. Each member body interested in a subject for which a technical committee has been established has the right to be represented on that committee. International organizations, governmental and non-governmental, in liaison with ISO, also take part in the work. ISO collaborates closely with the International Electrotechnical Commission (IEC) on all matters of electrotechnical standardization.

Draft International Standards adopted by the technical committees are circulated to the member bodies for approval before their acceptance as International Standards by the ISO Council. They are approved in accordance with ISO procedures requiring at least 75 % approval by the member bodies voting.

International Standard ISO 3795 was prepared jointly by Technical Committees ISO/TC 22, *Road vehicles*, and ISO/TC 23, *Tractors and machinery for agriculture and forestry*.

This second edition cancels and replaces the first edition (ISO 3795 : 1976), the scope of which has been extended to include tractors and machinery for agriculture and forestry.

© ISO 1989

All rights reserved. No part of this publication may be reproduced or utilized in any form or by any means, electronic or mechanical, including photocopying and microfilm, without permission in writing from the publisher.

International Organization for Standardization
Case postale 56 • CH-1211 Genève 20 • Switzerland

Printed in Switzerland

Introduction

Evaluation of burning behaviour of interior materials is based on the assumption that a fire in the passenger compartment is unlikely to occur when the burning rate of the interior material under the action of a small flame is zero or very small.

In the framework of international regulations for motor vehicle safety prepared by the competent groups of the Economic Commission for Europe (ECE/UNO), ISO had been requested to develop a method for the determination of the burning behaviour of interior materials in motor vehicles. Extensive information on existing test methods was collected and evaluated. In view of safety standards which are already mandatory, considerations were based primarily on the test procedure defined in US-FMVSS 302.

Considerable attention was devoted to the problem of ventilation of the combustion chamber. Two series of comparative tests were conducted to investigate different design variations.

After extended discussions, it was decided to incorporate the combustion chamber described in this International Standard.

Furthermore, it was decided to require the presence of supporting wires as part of the standard equipment in order to avoid subjective interpretations of sample behaviour by the test personnel.

.....

Road vehicles, and tractors and machinery for agriculture and forestry — Determination of burning behaviour of interior materials

1 Scope

This International Standard specifies a method for determining the horizontal burning rate of materials used in the occupant compartment of road vehicles (for example, passenger cars, lorries/trucks, estate cars, coaches), and of tractors and machinery for agriculture and forestry, after exposure to a small flame.

This method permits testing of materials and parts of the vehicle interior equipment individually or in combination up to a thickness of 13 mm. It is used to judge the uniformity of production lots of such materials with respect to their burning behaviour.

Because of the many differences between the real world situation (application and orientation within vehicle interior, conditions of use, ignition source, etc.) and the precise test conditions specified in this International Standard, this method cannot be considered as suitable for evaluation of all true in-vehicle burning characteristics.

2 Normative reference

The following standard contains provisions which, through reference in this text, constitute provisions of this International Standard. At the time of publication, the edition indicated was valid. All standards are subject to revision, and parties to agreements based on this International Standard are encouraged to investigate the possibility of applying the most recent edition of the standard indicated below. Members of IEC and ISO maintain registers of currently valid International Standards.

ISO 2768-1: 1989, *General tolerances — Part 1: Tolerances for linear and angular dimensions without individual tolerance indications*.

3 Definitions

For the purposes of this International Standard, the following definitions apply.

3.1 burning rate: Quotient of the burnt distance measured according to this International Standard and the time taken to burn this distance.

It is expressed in millimetres per minute.

3.2 composite material: Material composed of several layers of similar or different materials intimately held together at their surfaces by cementing, bonding, cladding, welding, etc.

When different materials are connected together intermittently (for example, by sewing, high-frequency welding, riveting), then in order to permit the preparation of individual samples in accordance with clause 6, such materials will not be considered as composite materials.

3.3 exposed side: Side which faces towards the occupant compartment when the material is mounted in the vehicle.

4 Principle

A sample is held horizontally in a U-shaped holder and is exposed to the action of a defined low-energy flame for 15 s in a combustion chamber, the flame acting on the free end of the sample. The test determines if and when the flame extinguishes or the time in which the flame passes a measured distance.

5 Apparatus

5.1 Combustion chamber (see figure 1), preferably of stainless steel and having the dimensions given in figure 2. The front of the chamber contains a flame-resistant observation window, which may cover the front and which can be constructed as an access panel.

The bottom of the chamber has vent holes, and the top has a vent slot all around. The combustion chamber is placed on four feet, 10 mm high.

The chamber may have a hole at one end for the introduction of the sample holder containing the sample; in the opposite end, a hole is provided for the gas line. Melted material is caught in a pan (see figure 3) which is placed on the bottom of the chamber between vent holes without covering any vent hole area.

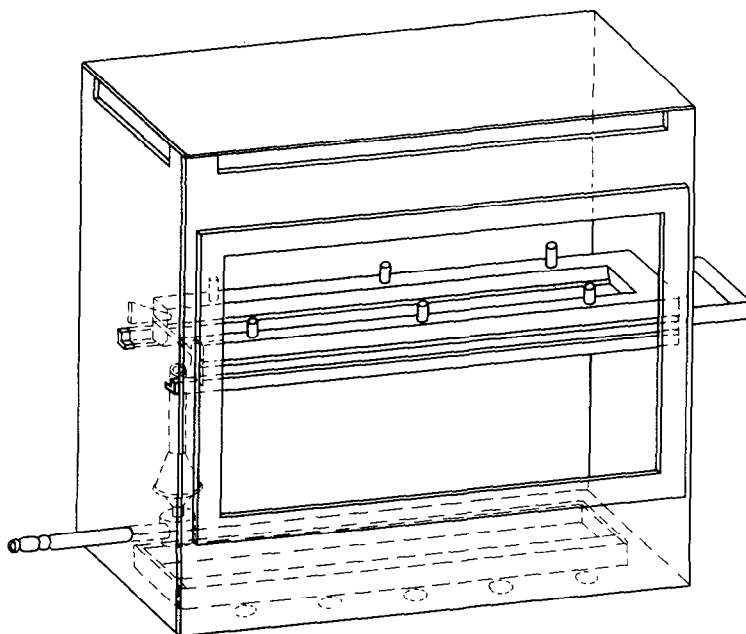

Figure 1 — Example of combustion chamber with sample holder and drip pan

Dimensions in millimetres
Tolerances according to ISO 2768-1

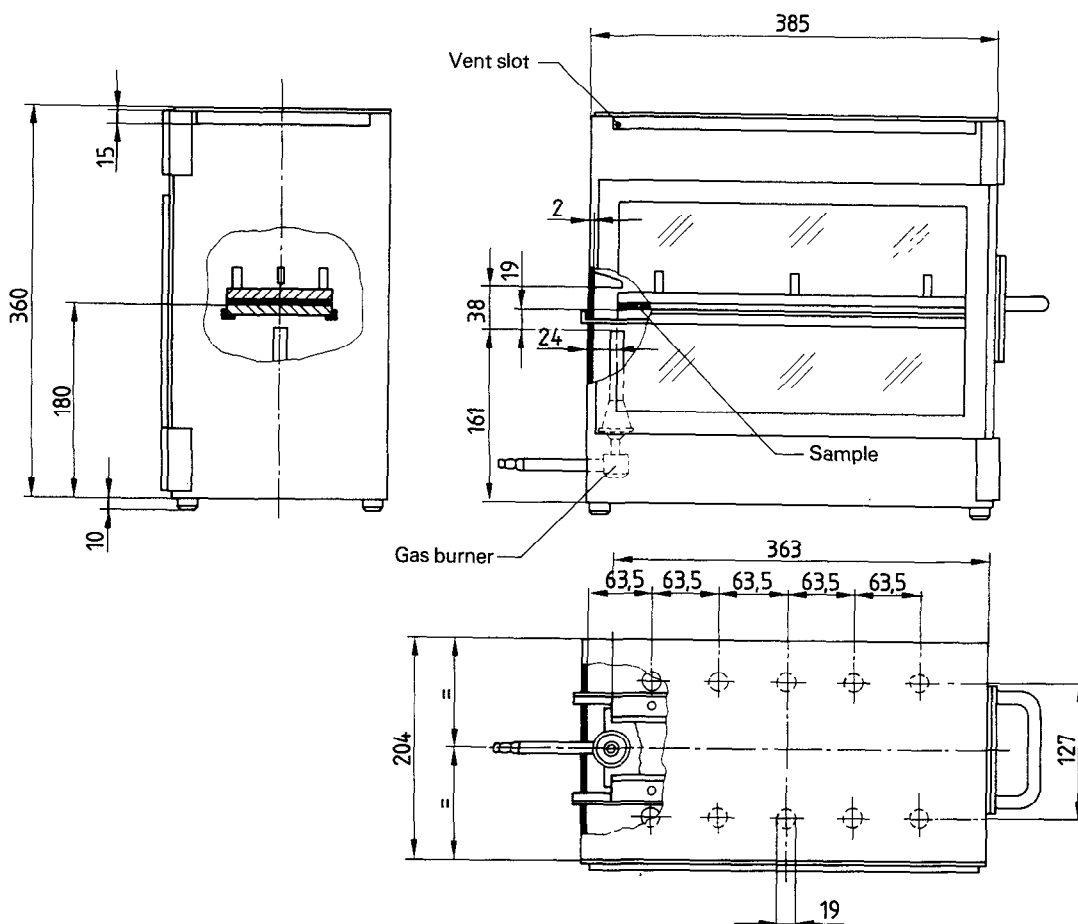

Figure 2 — Example of combustion chamber

Dimensions in millimetres
Tolerances according to ISO 2768-1

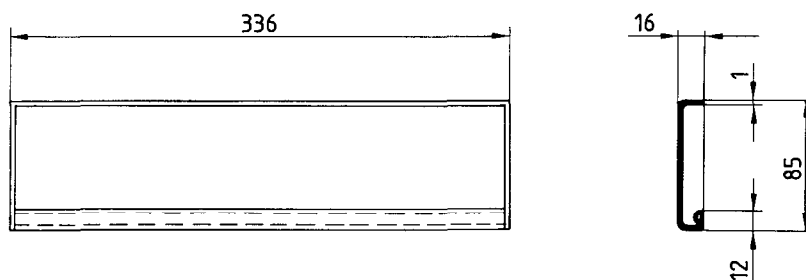

Figure 3 – Typical drip pan

5.2 Sample holder, consisting of two U-shaped metal plates or frames of corrosion-proof material. Dimensions are given in figure 4.

The lower plate is equipped with pins, the upper one with corresponding holes in order to ensure consistent holding of the sample. The pins also serve as the measuring points at the beginning and end of the burning distance.

A support shall be provided in the form of 0,25 mm diameter heat-resistant wires spanning the frame at 25 mm intervals over the bottom U-shaped frame (see figure 5).

The plane of the lower side of samples shall be 178 mm above the floor plate. The distance of the front edge of the sample

holder from the end of the chamber shall be 22 mm; the distance of the longitudinal sides of the sample holder from the sides of the chamber shall be 50 mm (all inside dimensions). (See figures 1 and 2.)

5.3 Gas burner. The small ignition source is provided by a Bunsen burner having an inside diameter of 9,5 mm. It is located in the test cabinet so that the centre of its nozzle is 19 mm below the centre of the bottom edge of the open end of the sample (see figure 2).

5.4 Test gas. The gas supplied to the burner shall have a calorific value of approximately 38 MJ/m³ (for example natural gas).

Dimensions in millimetres
Tolerances according to ISO 2768-1 if not otherwise indicated

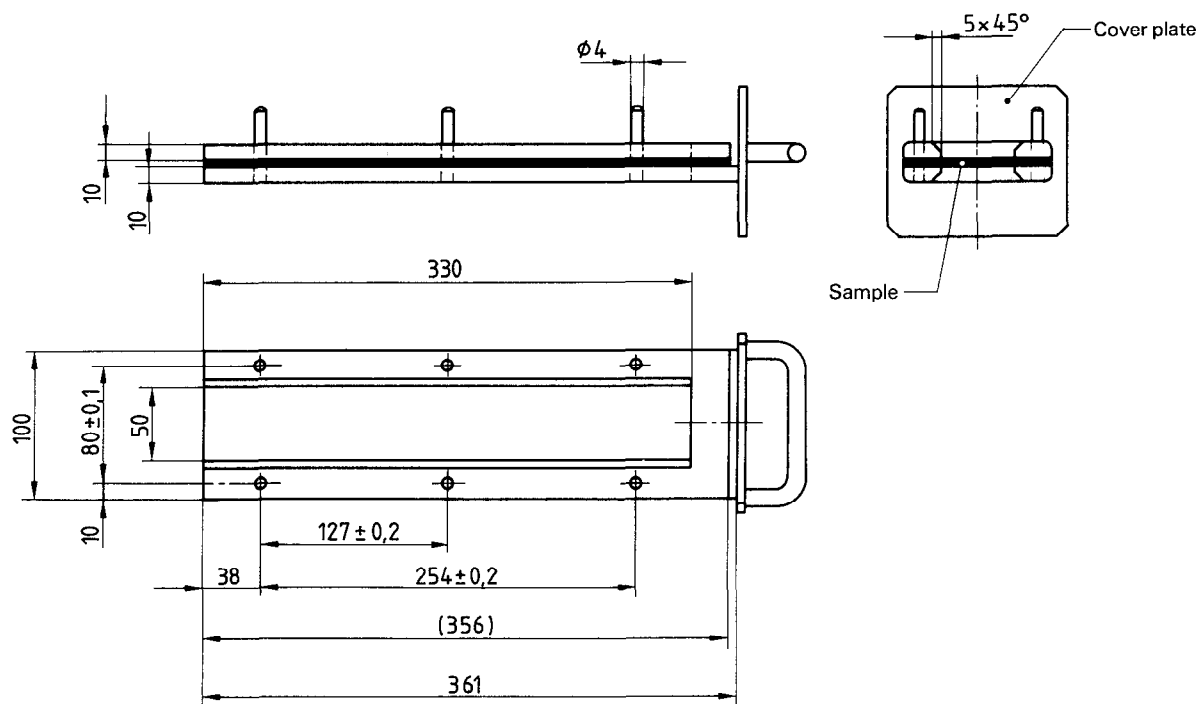

Figure 4 – Example of sample holder

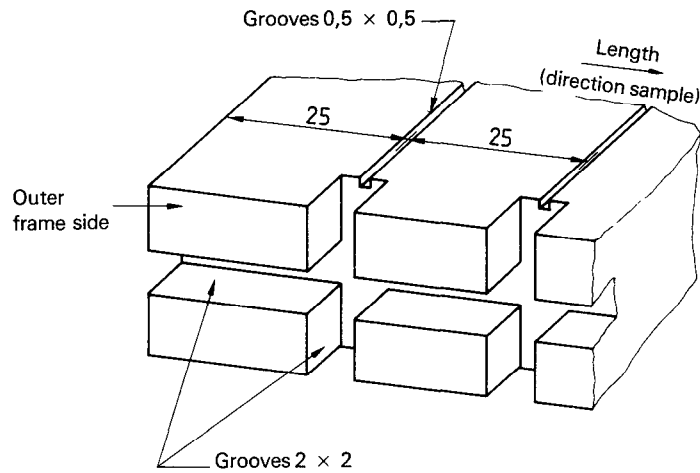

Figure 5 – Example of section of lower U-frame design for wire support facility

5.5 Metal comb, at least 110 mm in length, with seven to eight smooth rounded teeth per 25 mm.

5.6 Stop-watch, accurate to 0,5 s.

5.7 Fume cupboard. The combustion chamber may be placed in a fume cupboard assembly provided that the internal volume is at least 20 times, but not more than 110 times, greater than the volume of the combustion chamber and provided that no single height, width, or length dimension of the fume cupboard is greater than 2,5 times either of the other two dimensions.

Before the test, the vertical velocity of the air through the fume cupboard shall be measured 100 mm in front of and behind the

final position where the combustion chamber will be located. It shall be between 0,1 m/s and 0,3 m/s in order to avoid possible discomfort, by combustion products, to the operator. It is possible to use a fume cupboard with natural ventilation and an appropriate air velocity.

6 Samples

6.1 Shape and dimensions

The shape and dimensions of samples are given in figure 6. The thickness of the sample corresponds to the thickness of the product to be tested. It shall not be more than 13 mm. When taking the sample permits, the sample shall have a constant section over its entire length.

Dimensions in millimetres

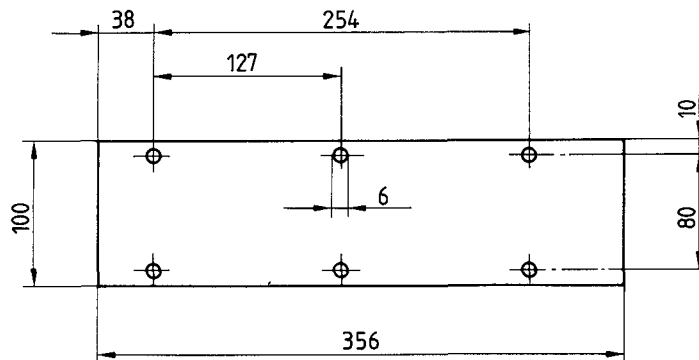

Figure 6 – Sample

When the shape and dimensions of a product do not permit taking a sample of the given size, the following minimum dimensions shall be maintained :

- a) For samples having a width of 3 mm to 60 mm, the length shall be 356 mm. In this case, the material is tested in the product width.
- b) For samples having a width of 60 mm to 100 mm, the length shall be at least 138 mm. In this case the potential burning distance corresponds to the length of the sample, the measurement starting at the first measuring point.
- c) Samples having a width of less than 60 mm and shorter than 356 mm, and samples having a width of 60 mm to 100 mm and shorter than 138 mm, cannot be tested according to this method ; neither can samples having a width less than 3 mm.

6.2 Sampling

At least five samples shall be taken from the material under test. In materials having different burning rates in different material directions (preliminary tests will show this), the five (or more) samples are to be taken and placed in the test apparatus so that the highest burning rate will be measured.

When the material is supplied in widths, a length of at least 500 mm shall be cut covering the entire width. From this, the samples shall be taken so as to be at least 100 mm from the material edge and equidistant from each other.

Samples shall be taken in the same way from finished products, when the shape of the product permits. When the thickness of the product is 13 mm or more, it shall be reduced to 13 mm by a mechanical process applied to the side which does not face the occupant compartment.

Composite materials (see 3.2) shall be tested as if they were of uniform construction.

In the case of materials made of superimposed layers of different composition which are not composite materials, all the layers of material included within a depth of 13 mm from the surface facing towards the occupant compartment shall be tested individually.

6.3 Conditioning

The samples shall be conditioned for at least 24 h but not more than 7 days at a temperature of 23 °C ± 2 °C and a relative humidity of 50 % ± 5 % and shall be maintained under these conditions until immediately prior to testing.

7 Procedure

7.1 Place samples with napped or tufted surfaces on a flat surface and comb twice against the nap using the comb (5.5).

7.2 Place the sample in the sample holder (5.2) so that the exposed side will be downwards to the flame.

7.3 Adjust the gas flame to a height of 38 mm using the mark in the chamber, the air intake of the burner (5.3) being closed. Before starting the first test, the flame shall burn at least for 1 min for stabilization.

7.4 Push the sample holder (5.2) into the combustion chamber (5.1) so that the end of the sample is exposed to the flame, and after 15 s cut off the gas flow.

7.5 The measurement of the burning time starts at the moment when the foot of the flame passes the first measuring point. Observe the flame propagation on the side burning faster than the other (upper or lower side).

7.6 Measurement of burning time is completed when the flame has come to the last measuring point or when the flame extinguishes before coming to the last measuring point. If the flame does not reach the last measuring point, measure the burnt distance up to the point where the flame extinguished. Burnt distance is the decomposed part of the sample, which is destroyed on its surface or in the interior by burning.

7.7 Insofar as the sample does not ignite or does not continue burning after the burner has been extinguished, or when the flame extinguishes before reaching the first measuring point, so that no burning time is measured, note in the test report that the burning rate is 0 mm/min.

7.8 When running a series of tests or repeat tests, ensure that the combustion chamber and sample holder have a maximum temperature of 30 °C before starting the next test.

8 Calculation

The burning rate, B , in millimetres per minute, is given by the formula

$$B = \frac{s}{t} \times 60$$

where

s is the burnt distance, in millimetres ;

t is the time, in seconds, to burn distance s .

9 Test report

The test report shall include the following particulars :

- a) type, marking and colour of the test sample ;
- b) whether the sample was a composite or a single material ;
- c) dimensions of the sample, including maximum and minimum values of thickness ;
- d) preparation of the sample, including the method of reducing the thickness (if thickness is greater than 13 mm) according to 6.2 ;
- e) position of sample in the product (lengthwise, transverse) ;
- f) number of samples tested ;
- g) test results :
 - burnt distance, in millimetres, and burning time, in seconds ;
 - other observations (self-extinguishing, etc.) ;
- h) all calculated single values of burning rate, in millimetres per minute ;
- i) special test conditions (use of fume cupboard, use of ventilator, etc.) ;
- j) any conditions different from those specified in this International Standard ;
- k) date of test.

1

UDC 629.11 : 536.468 : 620.1

Descriptors : road vehicles, tractors, agricultural machinery, composite materials, tests, fire tests, determination, fire resistance, burning rate.

Price based on 6 pages
