

INTERNATIONAL STANDARD

ISO 3772

Third edition
2000-10-15

Photography — Rolls of sensitized material for the pre-press industry — Dimensions and related requirements

*Photographie — Rouleaux de matériau sensible pour l'industrie de
préimpression — Dimensions et exigences connexes*



Reference number
ISO 3772:2000(E)

© ISO 2000

PDF disclaimer

This PDF file may contain embedded typefaces. In accordance with Adobe's licensing policy, this file may be printed or viewed but shall not be edited unless the typefaces which are embedded are licensed to and installed on the computer performing the editing. In downloading this file, parties accept therein the responsibility of not infringing Adobe's licensing policy. The ISO Central Secretariat accepts no liability in this area.

Adobe is a trademark of Adobe Systems Incorporated.

Details of the software products used to create this PDF file can be found in the General Info relative to the file; the PDF-creation parameters were optimized for printing. Every care has been taken to ensure that the file is suitable for use by ISO member bodies. In the unlikely event that a problem relating to it is found, please inform the Central Secretariat at the address given below.

© ISO 2000

All rights reserved. Unless otherwise specified, no part of this publication may be reproduced or utilized in any form or by any means, electronic or mechanical, including photocopying and microfilm, without permission in writing from either ISO at the address below or ISO's member body in the country of the requester.

ISO copyright office
Case postale 56 • CH-1211 Geneva 20
Tel. + 41 22 749 01 11
Fax + 41 22 749 09 47
E-mail copyright@iso.ch
Web www.iso.ch

Printed in Switzerland

Contents

Page

Foreword.....	iv
1 Scope	1
2 Normative references	1
3 Term and definition	1
4 Conditions for measurement of dimensions	1
5 Dimensions.....	2
5.1 Width of rolls	2
5.2 Length of rolls	2
5.3 Core internal diameter.....	2
5.4 Core length.....	2
5.5 Dimensions of disposable cassettes.....	2
6 Splices	5
7 Winding configuration.....	5
8 Disposable cassette pull-out force	5
9 Package marking	5
10 Compliance.....	6
Annex A (informative) Dimensional stability	7
Bibliography	8

Foreword

ISO (the International Organization for Standardization) is a worldwide federation of national standards bodies (ISO member bodies). The work of preparing International Standards is normally carried out through ISO technical committees. Each member body interested in a subject for which a technical committee has been established has the right to be represented on that committee. International organizations, governmental and non-governmental, in liaison with ISO, also take part in the work. ISO collaborates closely with the International Electrotechnical Commission (IEC) on all matters of electrotechnical standardization.

International Standards are drafted in accordance with the rules given in the ISO/IEC Directives, Part 3.

Draft International Standards adopted by the technical committees are circulated to the member bodies for voting. Publication as an International Standard requires approval by at least 75 % of the member bodies casting a vote.

Attention is drawn to the possibility that some of the elements of this International Standard may be the subject of patent rights. ISO shall not be held responsible for identifying any or all such patent rights.

International Standard ISO 3772 was prepared by Technical Committee ISO/TC 42, *Photography*.

This third edition of ISO 3772 cancels and replaces the second edition (ISO 3772:1991), and ISO 6407:1992, *Photography — Film dimensions — Graphic arts*; ISO 6408:1991, *Photography — Paper dimensions — Rolls for photocomposition*; and ISO 11313:1994, *Photography — Disposable cassettes containing photocomposition film and paper — Dimensions and related requirements*. These have been combined and revised, featuring a new emphasis on general cutting rules as opposed to listing all known sizes specifically.

The combination of these International Standards into a single International Standard results in a tightening of specified tolerances for certain sizes and applications.

This International Standard replaces a number of standards relating to rolls of sensitized material for the pre-press industry. It features a simplified set of rules for dimensioning new sizes. It is hoped that the use of this International Standard will promote the compatibility of sensitized material and equipment.

Annex A of this International Standard is for information only.

Photography — Rolls of sensitized material for the pre-press industry — Dimensions and related requirements

1 Scope

This International Standard specifies the dimensions of sensitized materials, cores and disposable cassettes, and describes package marking for sensitized materials, including those for electronic scanners or image-setting devices and those materials supplied in disposable cassettes.

It is applicable to photographic sensitized materials in rolls for use in the pre-press industry.

2 Normative references

The following normative documents contain provisions which, through reference in this text, constitute provisions of this International Standard. For dated references, subsequent amendments to, or revisions of, any of these publications do not apply. However, parties to agreements based on this International Standard are encouraged to investigate the possibility of applying the most recent editions of the normative documents indicated below. For undated references, the latest edition of the normative document referred to applies. Members of ISO and IEC maintain registers of currently valid International Standards.

ISO 1:1975, *Standard reference temperature for industrial length measurements*.

ISO 554:1976, *Standard atmospheres for conditioning and/or testing — Specifications*.

3 Term and definition

For the purposes of this International Standard, the following term and definition applies.

3.1

pre-press

that part of the printing or publishing process preceding preparation of a printing plate

NOTE It includes those applications previously defined as graphic arts, image-setting, photocomposition and scanner output.

4 Conditions for measurement of dimensions

The dimensions and tolerances specified in this International Standard apply at the time of manufacture, measured under atmospheric conditions of (23 ± 2) °C and (50 ± 5) % relative humidity, as specified in ISO 554.

All measuring instrument calibrations should be conducted at a temperature of 20 °C, as specified in ISO 1, and a relative humidity of 50 %.

5 Dimensions

5.1 Width of rolls

It is preferred that cutting sizes conform to the rules given in Table 1. Specific sizes that for historical reasons do not conform to these rules are specified in Table 2.

5.2 Length of rolls

The preferred length of rolls in disposable cassettes shall be 30 m for film and 45 m for paper. The preferred nominal length of rolls not in cassettes shall be 60 m. Actual useable length at the time of finishing shall not be less than the nominal length. Recognized nominal roll lengths are specified in Table 3.

5.3 Core internal diameter

The following internal diameters of cores shall be preferred:

50,7 mm ± 0,3 mm

71,9 mm ± 0,5 mm

The following internal diameters of cores are recognized:

28,8 mm ± 0,3 mm

71,2 mm ± 0,3 mm

5.4 Core length

The core shall not protrude and shall not be recessed by more than 3,0 mm.

5.5 Dimensions of disposable cassettes

The cassette dimensions shall conform to the values given in Table 4 and shown in Figure 1.

Table 1 — Cutting rules for roll widths

Dimensions in millimetres

Width of sensitized material		
Nominal	Aim	Tolerance
Up to and including 150	Nominal minus 0,25	± 0,25
Greater than 150, up to and including 260	Nominal minus 0,5	± 0,5
Greater than 260	Nominal minus 0,8	± 0,8

Table 2 — Dimensions for recognized roll widths

Widths of sensitized materials for pre-press ^a			
Nominal cm	Aim mm	Minimum mm	Maximum mm
22,9	228,2	227,8	228,6
30,5	304,0	303,2	304,8
35,6	354,8	354	355,6
45,7	456,4	455,6	457,2
50,8	507,2	506,4	508
71	710,0	709,5	710,5
76,2	761,2	760,4	762
83,8	838,0	837,5	838,5
91,4	913,6	912,8	914,4
94	940,0	939,2	940,8
106,6	1 066,0	1 065,2	1 066,8
111,7	1 117,0	1 116,2	1 117,8

^a Originally in inches (see 5.1).

Table 3 — Recognized roll lengths

Nominal length m
10
20
30
30,5
34,5
45
45,7
55
61,0
75
120
122,0

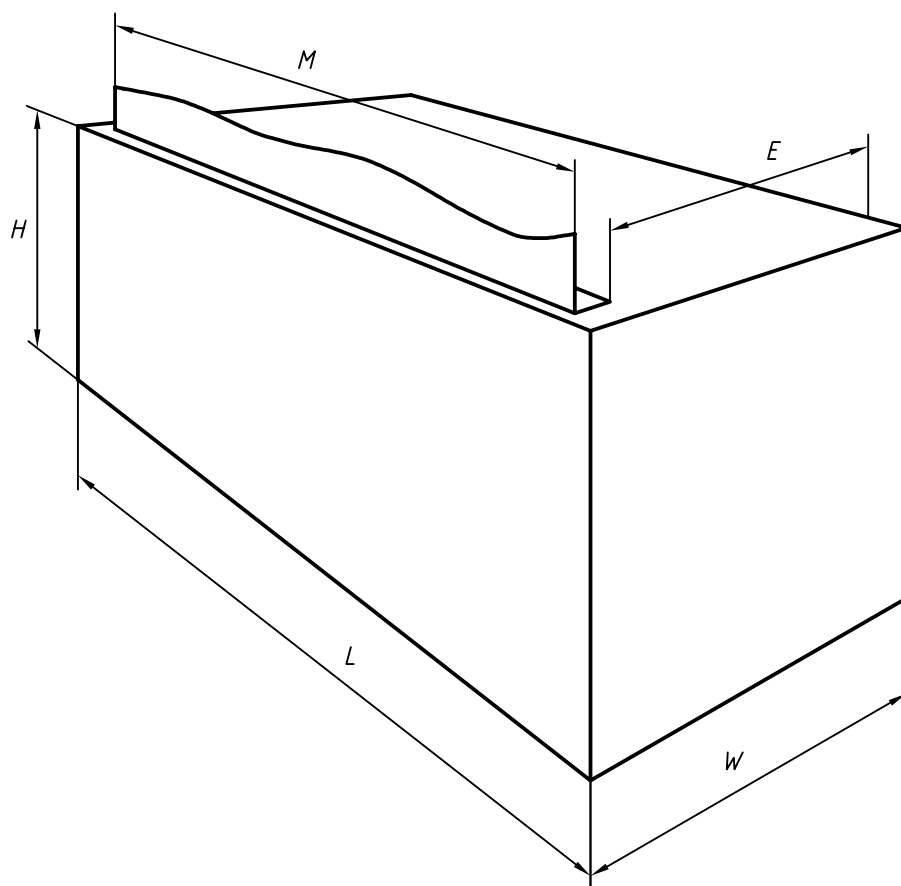

Dimension *W* shall never be less than dimension *E* on any single cassette. Dimension *M* is the width of the sensitized material given in Tables 1 and 2.

Dimension	Description	Minimum mm	Maximum mm
<i>L</i>	Length	see Table 4	see Table 4
<i>H</i>	Nominal height	94	102
<i>W</i>	Nominal width	94	111
<i>E</i>		88	98

Figure 1 — Disposable cassette dimensions

Table 4 — Dimensions for disposable cassettes

Dimensions in millimetres

Nominal width of sensitized material	Minimum cassette length	Maximum cassette length	Maximum pull-out force N
Up to and including 150	Nominal plus 11,5	Nominal plus 33,5	10
Greater than 150	Nominal plus 12,0	Nominal plus 34,0	14

6 Splices

There shall be no splices in rolls of sensitized materials for the pre-press industry.

7 Winding configuration

The overall width of the roll (including any widthwise winding deviations) shall not exceed the nominal width of the sensitized material by more than 2 mm.

NOTE Rolls of sensitized materials may be wound with either the sensitized side in or with the sensitized side out.

8 Disposable cassette pull-out force

The shape and dimensions of all parts of the cassette and its contents shall be such that the force required to pull the sensitized material out of the cassette, following initial manual release, shall not exceed the values as given in Table 4, regardless of how much sensitized material remains in the cassette.

9 Package marking

Sufficient data shall be provided on a product's packaging to inform the user of proper use and handling.

Product packaging shall be marked so as to indicate:

- product name and size;
- conditions of use (such as safelight);
- conditions of shipping and storage.

To accomplish this, each of the packages which constitute the product's packaging should be marked so as to indicate one or more of the following¹⁾:

- product name or tradename; for unit packages, reasonable effort shall be made to make this item legible under recommended safelight conditions;
- name or trademark of the manufacturer;
- manufacturer's catalogue identification number;
- bar code information;
- information to assist recycling of waste packaging;
- quantity of units contained in the package;
- product name or tradename of sensitized material;
- nominal product dimensions, in metric units, with the smallest dimension first;
- batch number and/or parent roll number;

¹⁾ There may be legal requirements in certain countries for other data to be marked on the package.

ISO 3772:2000(E)

- expiration date or “develop before” date or inventory control code;
- manufacturer's recommended safelight conditions²⁾;
- manufacturer's recommended storage conditions²⁾;
- Indication of winding, if applicable²⁾.

10 Compliance

If it is desired to indicate compliance of the product with this International Standard, the following wording shall be used:

“COMPLYING WITH ISO 3772”

²⁾ This may be indicated by wording or by a code.

Annex A (informative)

Dimensional stability

The dimensions and tolerances specified apply at the time of manufacture and when measured in equilibrium with the standard atmosphere specified in ISO 554; i.e. temperature (23 ± 2) °C and relative humidity (50 ± 5) %.

These dimensions may be altered by permanent ageing shrinkage and by temporary shrinkage and swell, since they will change with the temperature and the moisture content of the atmosphere.

Nevertheless, at the time of package opening within the warranty period of the sensitized material, dimensions measured under atmospheric conditions of temperature (23 ± 2) °C and relative humidity (50 ± 5) % should not depart from those at the time of manufacture by more than 0,05 % greater than the maximum tolerance, or 0,05 % less than the minimum tolerance.

Samples of paper cut from a roll require a minimum of 14 days conditioning for resin-coated paper and a minimum of 8 h for non-resin-coated paper as specified in ISO 6221.

Bibliography

- [1] ISO 6221:1996, *Photography — Films and papers — Determination of dimensional change.*
- [2] ISO 11312, *Photography — Sheets of sensitized material for the pre-press industry — Dimensions and related requirements.*
- [3] ISO 14535, *Photography — Room-light loading packages for electronic scanner and image-setting film and paper rolls — Dimensions and related requirements.*

