

INTERNATIONAL
STANDARD

ISO
3764

Fourth edition
2016-03-01

**Timekeeping instruments —
Movements — Types, dimensions and
nomenclature**

*Instruments horaires — Mouvements — Formes, dimensions et
nomenclature*



Reference number
ISO 3764:2016(E)

© ISO 2016



COPYRIGHT PROTECTED DOCUMENT

© ISO 2016, Published in Switzerland

All rights reserved. Unless otherwise specified, no part of this publication may be reproduced or utilized otherwise in any form or by any means, electronic or mechanical, including photocopying, or posting on the internet or an intranet, without prior written permission. Permission can be requested from either ISO at the address below or ISO's member body in the country of the requester.

ISO copyright office
Ch. de Blandonnet 8 • CP 401
CH-1214 Vernier, Geneva, Switzerland
Tel. +41 22 749 01 11
Fax +41 22 749 09 47
copyright@iso.org
www.iso.org

Contents

Page

Foreword	iv
1 Scope	1
2 Normative references	1
3 Terms and definitions	1
3.1 Diameters of movements	1
3.2 Thickness of movements	2
3.2.1 Mechanical type	2
3.2.2 Electromechanical type	2
4 Nomenclature of movements and their dimensions	2
4.1 Type 1: Round movement	2
4.2 Type 2: Shaped round movement	4
4.3 Type 3: Round movement with double cutting	5
4.4 Type 4: 5 ½''' movement	6
4.5 Type 5: 6 ¾ × 8''' movement	7
5 Nomenclature for thickness of movements	8
5.1 Mechanical movements	8
5.2 Electromechanical movements with analogue display	8

Foreword

ISO (the International Organization for Standardization) is a worldwide federation of national standards bodies (ISO member bodies). The work of preparing International Standards is normally carried out through ISO technical committees. Each member body interested in a subject for which a technical committee has been established has the right to be represented on that committee. International organizations, governmental and non-governmental, in liaison with ISO, also take part in the work. ISO collaborates closely with the International Electrotechnical Commission (IEC) on all matters of electrotechnical standardization.

The procedures used to develop this document and those intended for its further maintenance are described in the ISO/IEC Directives, Part 1. In particular the different approval criteria needed for the different types of ISO documents should be noted. This document was drafted in accordance with the editorial rules of the ISO/IEC Directives, Part 2. www.iso.org/directives

Attention is drawn to the possibility that some of the elements of this document may be the subject of patent rights. ISO shall not be held responsible for identifying any or all such patent rights. Details of any patent rights identified during the development of the document will be in the Introduction and/or on the ISO list of patent declarations received. www.iso.org/patents

Any trade name used in this document is information given for the convenience of users and does not constitute an endorsement.

For an explanation on the meaning of ISO specific terms and expressions related to conformity assessment, as well as information about ISO's adherence to the WTO principles in the Technical Barriers to Trade (TBT), see the following URL: [Foreword - Supplementary information](#)

The committee responsible for this document is ISO/TC 114, *Horology*, Subcommittee SC 7, *Overall dimensions*.

This fourth edition cancels and replaces the third edition (ISO 3764:2000), which has been technically revised.

Timekeeping instruments — Movements — Types, dimensions and nomenclature

1 Scope

This International Standard specifies the types and fitting dimensions of mechanical and electromechanical watch-movements.

This International Standard is applicable to the five following types of movements:

- Type 1: round;
- Type 2: shaped round;
- Type 3: round with double cutting;
- Type 4: 5 ½'';
- Type 5: 6 ¾ × 8''.

2 Normative references

The following documents, in whole or in part, are normatively referenced in this document and are indispensable for its application. For dated references, only the edition cited applies. For undated references, the latest edition of the referenced document (including any amendments) applies.

ISO 286-1, *Geometrical product specifications (GPS) — ISO code system for tolerances on linear sizes — Part 1: Basis of tolerances, deviations and fits*

ISO 6426-2, *Horological vocabulary — Part 2: Technical and commercial definitions*

3 Terms and definitions

For the purposes of this document, the terms and definitions given in ISO 286-1 and ISO 6426-2, and the following apply.

3.1 Diameters of movements

3.1.1

case diameter

d_1

diameter of a plate, or an equivalent part or an assembly unit, by which the movement is located in the watch-case

3.1.2

outer diameter

d_2

largest diameter of the movement, on the flange of the plate, of an equivalent part or of an assembly unit

3.2 Thickness of movements

3.2.1 Mechanical type

3.2.1.1

total thickness of the movement

l_1

thickness embracing all the movement parts, including the distance between the dial support surface and the greatest protruding part of the movement

3.2.2 Electromechanical type

3.2.2.1

total thickness of the movement without battery

l_1

thickness embracing all the movement parts, including the distance between the dial support surface and the greatest protruding part of the movement

3.2.2.2

total thickness of the movement with a battery

l_2

greatest distance between the dial support surface and the most protruding surface of the battery

Note 1 to entry: If the battery is not the most protruding part, the total movement thickness is determined as l_1 .

3.2.2.3

total thickness of the movement including a battery and its fastening clamp

l_3

greatest distance between the dial support surface and the most protruding surface of the clamp

Note 1 to entry: If the battery with its clamp is not the most protruding part, the total movement thickness is determined as l_1 .

Note 2 to entry: For watches with analogue display, the total thickness of the movement does not include the projection of the hand-fastening elements nor the elements providing electrical contact with the case.

4 Nomenclature of movements and their dimensions

4.1 Type 1: Round movement

See [Figure 1](#) and [Table 1](#).

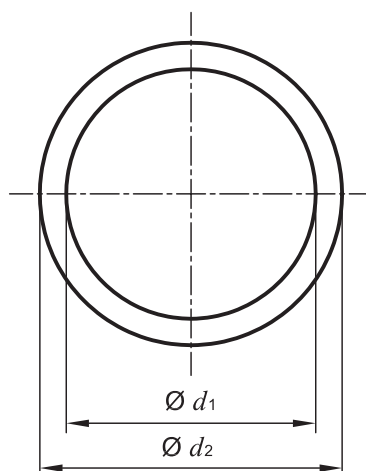
**Key**

- d_1 casing diameter
 d_2 outer diameter

Figure 1 — Round movement (view from the side of the bridges)**Table 1 — Type 1: Round movements**

Dimensions in millimetres

d_1 tol. h8	d_2 tol. h8
10,0 *	10,4
12,0	12,4
13,0	13,4
15,3 *	15,7
16,0	16,4
17,2 *	17,6
19,4 *	20,0
21,0	21,6
22,0	22,6
23,3 *	23,9
24,0	24,6
25,6 *	26,2
28,0	28,6
30,0	30,6
36,0	36,8
40,0	40,8

NOTE 1 The values d_1 with an asterisk are the preferred values.
NOTE 2 The tolerances only apply to metallic movements.
NOTE 3 See ISO 286-1 for definition of the tolerances.

4.2 Type 2: Shaped round movement

See [Figure 2](#) and [Table 2](#).

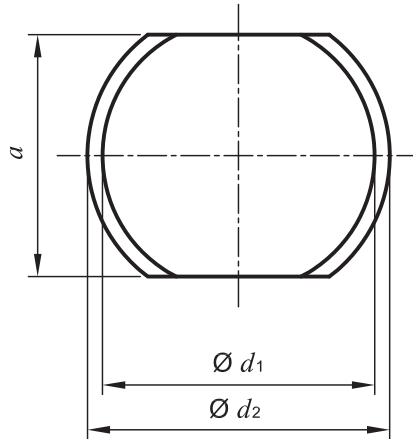

Key

- a width
- d_1 casing diameter
- d_2 outer diameter

Figure 2 — Shaped round movement (view from the side of the bridges)

Table 2 — Type 2: Shaped round movements

Dimensions in millimetres

d_1 tol. h8	d_2 tol. h8
10,0	10,4
13,0	13,4
15,3	15,7
17,2	17,6
17,5	17,9
19,4	20,0
23,3	24,0
25,6	26,4
26,6	27,2

NOTE 1 The tolerances only apply to metallic movements.
 NOTE 2 Width a is not specified.
 NOTE 3 See ISO 286-1 for definition of the tolerances.

4.3 Type 3: Round movement with double cutting

See [Figure 3](#) and [Table 3](#).

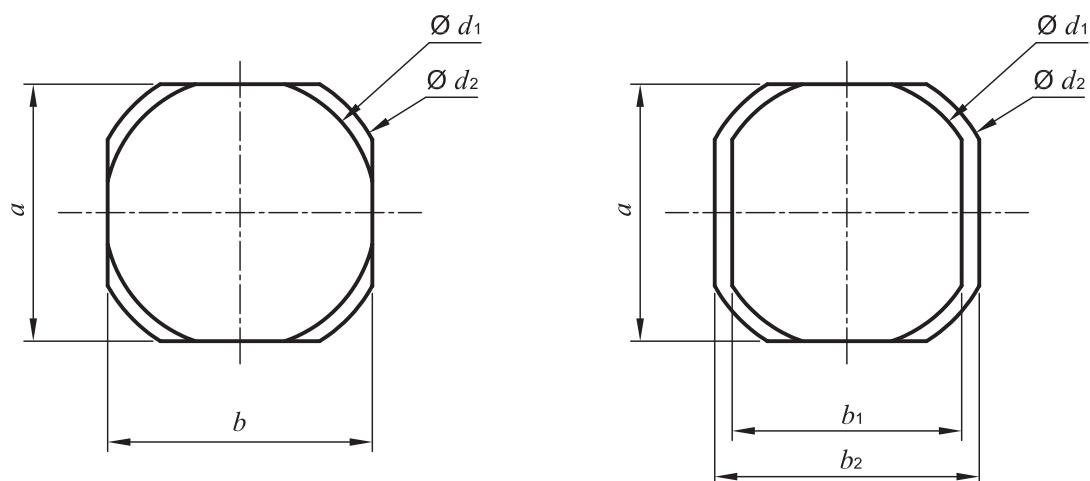

Key

a	width
b	length
b_1	fitting length
b_2	overall length
d_1	casing diameter
d_2	outer diameter

Figure 3 — Round movement with double cutting (view from the side of the bridges)

Table 3 — Type 3: Round movements with double cutting

Dimensions in millimetres

d_1 tol. h8	d_2 tol. h8
13,0	13,4
23,3	23,9
25,6	26,2

NOTE 1 The tolerances only apply to metallic movements.
 NOTE 2 Width a , fitting length b_1 and overall length b_2 are not specified.
 NOTE 3 See ISO 286-1 for definition of the tolerances.

4.4 Type 4: 5 1/2''' movement

See [Figure 4](#) and [Table 4](#).

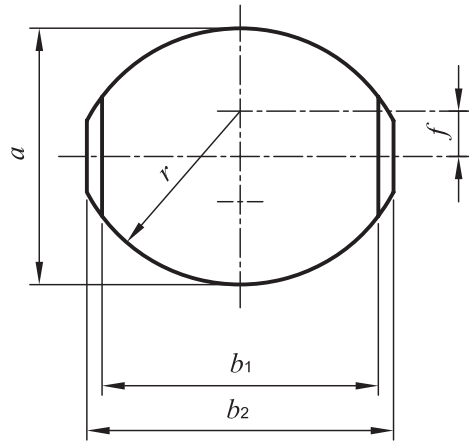

Key

- a width
- b_1 fitting length
- b_2 overall length
- f offset of the radius centre
- r oval radius

Figure 4 — 5 1/2''' movement (view from the side of the bridges)

Table 4 — Type 4: 5 1/2''' movements

Dimensions in millimetres

a tol. h9	b_1 tol. h8	b_2 tol. h9	f	r
13,0	15,15	15,55	2,3	8,8
NOTE 1 The tolerances only apply to metallic movements.				
NOTE 2 See ISO 286-1 for definition of the tolerances.				

4.5 Type 5: 6 3/4 × 8''' movement

See [Figure 5](#) and [Table 5](#).

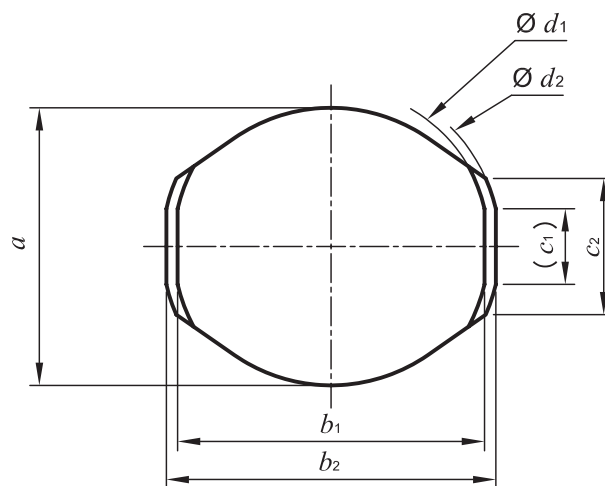

Key

a	width
b_1	fitting length
b_2	overall length
(c_1)	length of a flat part
c_2	length of the circular part
d_1	casing diameter
d_2	outer diameter

Figure 5 — 6 3/4 × 8''' movement (view from the side of the bridges)

Table 5 — Type 5: 6 3/4 × 8''' movements

Dimensions in millimetres

d_1 tol. h8	d_2 tol. h8	a tol. h9	b_1 tol. h8	b_2 tol. h9	(c_1)	c_2
18,1	18,5	15,3	17,8	18,2	3,32	7,3
NOTE 1 The tolerances only apply to metallic movements.						
NOTE 2 See ISO 286-1 for definition of the tolerances.						
NOTE 3 The value c_1 is given as an indication.						

5 Nomenclature for thickness of movements

5.1 Mechanical movements

See Figure 6.

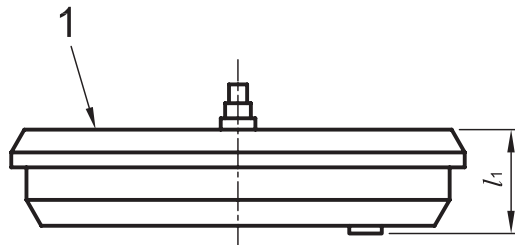

Key

- 1 support surface
- l_1 total thickness of the movement

Figure 6 — Mechanical movement

5.2 Electromechanical movements with analogue display

See [Figure 7](#).

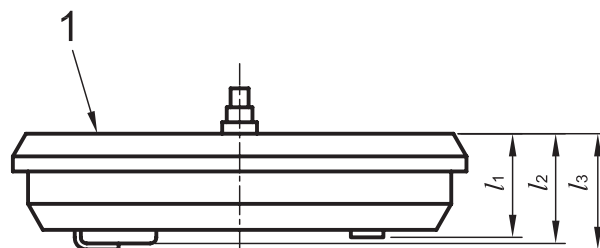

Key

- 1 dial support surface
- l_1 total thickness of the movement
- l_2 total thickness of the movement with a battery
- l_3 total thickness of the movement with a battery and with a battery-fastening clamp

Figure 7 — Electromechanical movement with analogue display

