

INTERNATIONAL STANDARD

ISO
3733

Second edition
1999-09-15

Petroleum products and bituminous materials — Determination of water — Distillation method

*Produits pétroliers et produits bitumineux — Dosage de l'eau — Méthode
par distillation*



Reference number
ISO 3733:1999(E)

Contents

1 Scope	1
2 Normative references	1
3 Principle	1
4 Reagents	2
4.1 Aromatic solvent	2
4.2 Petroleum distillate solvent	2
4.3 Paraffinic solvents	2
5 Apparatus	2
5.1 General	2
6 Verification and recovery test	6
6.1 General	6
6.2 Verification	6
6.3 Recovery test	6
7 Sampling (see annex A)	7
7.1 General	7
7.2 Laboratory sample	7
7.3 Preparation of the test samples	7
8 Procedure	7
9 Calculation	8
10 Expressions of results	9
11 Precision	9
11.1 Repeatability	9
11.2 Reproducibility	9
12 Test report	10
Annex A (normative) Sample handling	11

© ISO 1999

All rights reserved. Unless otherwise specified, no part of this publication may be reproduced or utilized in any form or by any means, electronic or mechanical, including photocopying and microfilm, without permission in writing from the publisher.

International Organization for Standardization
Case postale 56 • CH-1211 Genève 20 • Switzerland
Internet iso@iso.ch

Printed in Switzerland

Foreword

ISO (the International Organization for Standardization) is a worldwide federation of national standards bodies (ISO member bodies). The work of preparing International Standards is normally carried out through ISO technical committees. Each member body interested in a subject for which a technical committee has been established has the right to be represented on that committee. International organizations, governmental and non-governmental, in liaison with ISO, also take part in the work. ISO collaborates closely with the International Electrotechnical Commission (IEC) on all matters of electrotechnical standardization.

International Standards are drafted in accordance with the rules given in the ISO/IEC Directives, Part 3.

Draft International Standards adopted by the technical committees are circulated to the member bodies for voting. Publication as an International Standard requires approval by at least 75 % of the member bodies casting a vote.

ISO 3733 was prepared by Technical Committee ISO/TC 28, *Petroleum products and lubricants*, Subcommittee SC 6, *Bulk cargo transfer, accountability, inspection and reconciliation*.

This second edition cancels and replaces the first edition (ISO 3733:1976), of which it constitutes a technical revision.

Annex A forms an integral part of this International Standard.

Petroleum products and bituminous materials — Determination of water — Distillation method

WARNING — The use of this International Standard may involve hazardous materials, operations and equipment. This International Standard does not purport to address all of the safety problems associated with its use. It is the responsibility of the user of this International Standard to establish appropriate safety and health practices and determine the applicability of regulatory limitation prior to use.

1 Scope

This International Standard specifies a method for determination of water up to 25 % in petroleum products, bitumens, tars and products derived from these materials, excluding emulsions, by the distillation method. The specific products considered during the development of this test method are listed in Table 3.

This International Standard may be used to determine water content in excess of 25 %. However, no precision data has been determined at levels greater than 25 %. Volatile water-soluble material, if present, is measured as water.

NOTE 1 A knowledge of the water content of petroleum products is important in the refining, purchase, sale and transfer of products.

NOTE 2 The amount of water determined by this method can be used to correct the volume involved in the custody transfer of product.

2 Normative references

The following normative documents contain provisions which, through reference in this text, constitute provisions of this International Standard. For dated references, subsequent amendments to, or revisions of, any of these publications do not apply. However, parties to agreements based on this International Standard are encouraged to investigate the possibility of applying the most recent editions of the normative documents indicated below. For undated references, the latest edition of the normative document referred to applies. Members of ISO and IEC maintain registers of currently valid International Standards.

ISO 3170:1988, *Petroleum liquids — Manual sampling*.

ISO 3171:1988, *Petroleum liquids — Automatic pipeline sampling*.

ISO 3405:—¹⁾, *Petroleum products — Determination of distillation characteristics at atmospheric pressure*.

3 Principle

The test material is heated under reflux with a water-immiscible solvent, which co-distills with the water in the sample. Condensed solvent and water are continuously separated in a trap, the water settling in the graduated section of the trap and the solvent returning to the still.

¹⁾ To be published. (Revision of ISO 3405:1988)

4 Reagents

NOTE For the purposes of this International Standard, the expression “% (V/V)” is used to represent the volume fraction of a material.

A solvent-carrier liquid appropriate to the materials being tested (see Table 3) shall be used.

4.1 Aromatic solvent

The following aromatic solvents, free of water (0,02 % maximum) are suitable:

- a) industrial grade xylene (mixed xylenes);
- b) a blend of 20 % (V/V) industrial grade toluene and 80 % (V/V) industrial grade xylene (mixed xylenes);
- c) petroleum distillate, yielding not more than 5 % (V/V) distillates at 125 °C and not less than 20 % (V/V) at 160 °C when tested in accordance with ISO 3405 and with a density not lower than 855 kg/m³ at 15 °C.

4.2 Petroleum distillate solvent

A petroleum solvent, free of water, of which 5 % (V/V) boils between 90 °C and 100 °C, and 90 % (V/V) distils below 210 °C.

4.3 Paraffinic solvents

The following paraffinic solvents, free of water, are suitable:

- a) light petroleum with a boiling range of 100 °C to 120 °C;
- b) 2,2,4-trimethylpentane (*iso*-octane) of 95 % purity or better.

5 Apparatus

5.1 General

The apparatus comprises a glass or metal still, a heater, a reflux condenser, and a graduated glass trap. The still, trap and condenser shall be connected by any suitable method that produces a leak-proof joint. Preferred connections are ground joints for glass, and O-rings for metal to glass. Typical assemblies of the glassware are shown in Figures 1 to 3 and the dimensions are given in Table 1. Any given testing apparatus will be deemed suitable, if accurate results are obtained using the methods described in 6.2 and 6.3. However, a straight water-cooled condenser with a length of 400 mm is recommended. The stills and traps shall be chosen to cover the range of materials and water contents expected. If the amount of water collected is likely to exceed 25 ml, a 25 ml trap fitted with a stopcock shall be used and the excess water shall be drained off into a graduated cylinder meeting the requirements of 6.2 and 6.3.

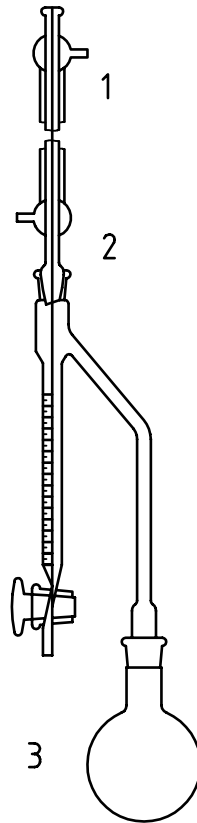

Key

- 1 Condenser
- 2 Receiver
- 3 Distillation vessel

Figure 1 — Typical assembly with glass still (Dean and Stark apparatus)

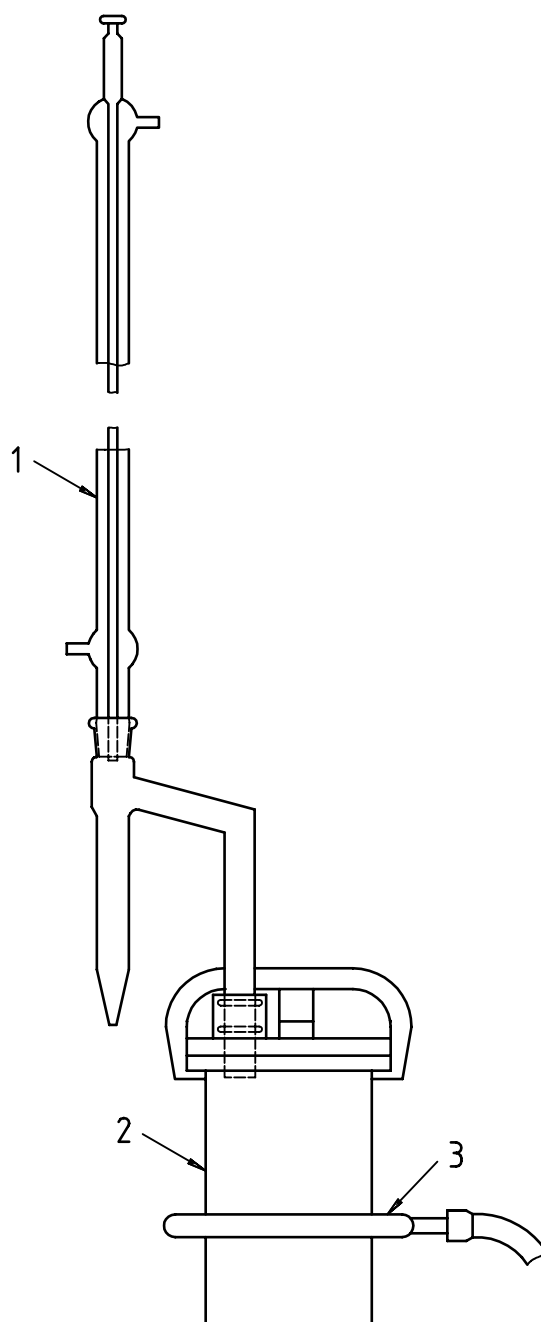
**Key**

- 1 Water-cooled condenser
- 2 Metal still
- 3 Ring burner

Figure 2 — Typical assembly with metal still

Dimensions in millimetres

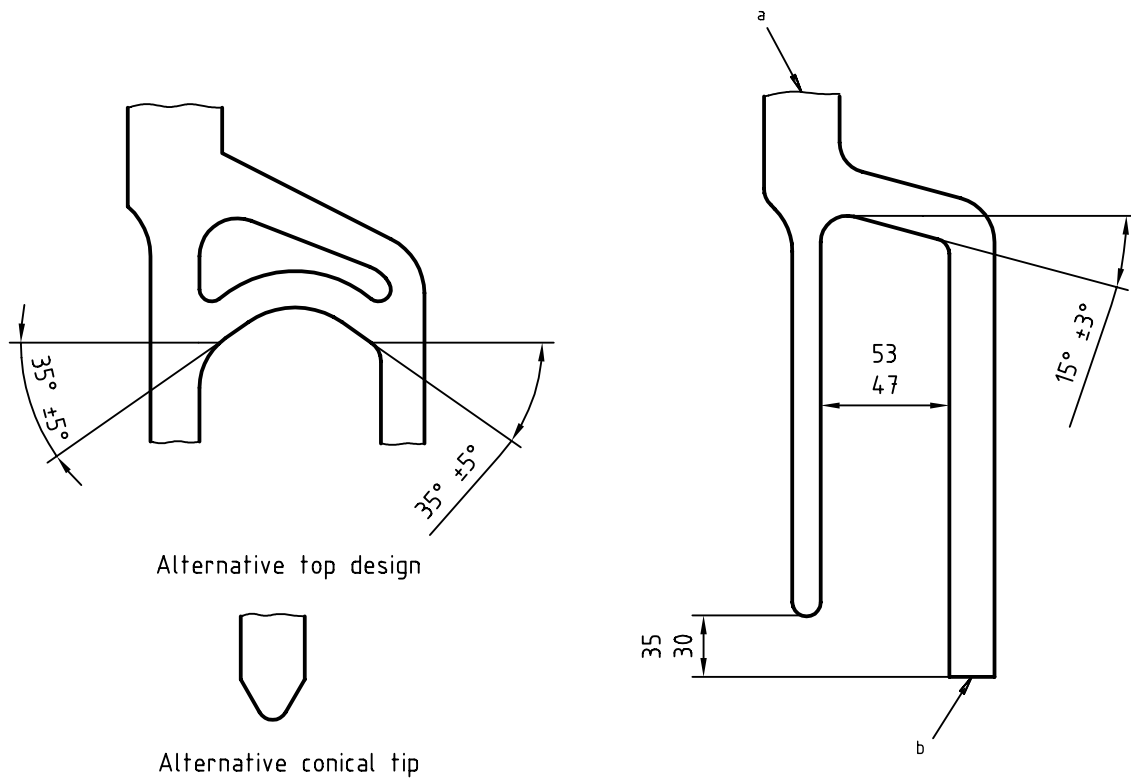

NOTE 1 Dimensions than those shown other in Table 1 are for guidance only.

NOTE 2 25 ml traps may be fitted with a stopcock if required.

- a Top finish:
beaded edge;
or
conical ground-glass joint, ISO 383/24/29 socket;
or
spherical ground-glass joint, ISO 641/35/20 cup.
- b Bottom finish:
fire polished;
or
conical ground-glass joint, ISO 383/24/29 cone;
or
spherical ground-glass joint, ISO 641/35/20 ball.

Figure 3 — Details of typical traps

Table 1 — Essential requirements of traps

Trap size, ml	2	5	10		25		
Scale range, ml	0 to 2	0 to 5	0 to 1	>1 to 10	0 to 10	0 to 1	>1 to 25
Smallest scale division, ml	0,05	0,05	0,1	0,2	0,1	0,1	0,2
Maximum scale error, ml	0,025	0,05	0,05	0,1	0,1	0,05	0,1
Bottom of graduated tube	round	round	conical		round	conical	
Length of graduated portion, mm	85 to 105	120 to 140	120 to 140		120 to 140	140 to 160	

5.2 Still, comprising a glass or metal vessel with a short neck and a suitable joint for accommodating the reflux tube of the trap. Vessels of nominal capacity 500 ml, 1 000 ml and 2 000 ml have proved satisfactory. The metal still shall be fitted with a heat-resistant gasket of material other than asbestos.

5.3 Heater, a suitable electric heater may be used with the glass still. A heater combined with a magnetic stirrer has proved to be effective to avoid bumping. A gas ring burner with ports on the inside circumference shall be used with the metal still. The gas ring burner shall be of such dimensions that it can be moved up and down the vessel when testing materials that are likely to foam or solidify in the still.

6 Verification and recovery test

6.1 General

Before initial use, verify the accuracy of the trap in accordance with 6.2. Before using the apparatus, carry out a recovery test in accordance with 6.3.

6.2 Verification

Before initial use, verify the accuracy of the graduation marks on the trap by adding 0,05 ml increments of distilled water from a 5 ml microburette or a precision micropipette readable to the nearest 0,01 ml. If there is a deviation of more than 0,05 ml between the water added and water observed, reject the trap or recalibrate.

6.3 Recovery test

Before using the apparatus for a water determination, test the overall recovery of water in the entire apparatus by introducing 250 ml to 1 000 ml of dry (0,02 % water maximum) xylene, according to the size of the vessel, to the apparatus (500 ml to 2 000 ml vessel as specified in 5.2) and proceed as described in clause 8. When complete, discard the contents of the trap, allow the contents of the still to cool and add the appropriate quantity of distilled water from a burette directly to the distillation flask in accordance with Table 2, and proceed as described in clause 8. The readings shall be judged accurate if the permissible limits given in Table 2 for graduated traps of different sizes are not exceeded.

Table 2 — Permissible limits for water recovery

Values in millilitres

Capacity of trap at 20 °C	Volume of water added to flask at 20 °C	Permissible limits for recovered water at 20 °C
2	1,00	1,0 ± 0,025
5	1,00	1,0 ± 0,025
5	4,50	4,5 ± 0,025
10	1,0	1 ± 0,1
10	5,0	5 ± 0,25
25	12,0	12 ± 0,25

A reading outside the permissible limits indicates malfunction due to vapour leaks, too rapid boiling, or ingress of extraneous moisture. Eliminate these factors and repeat the recovery test.

7 Sampling (see annex A)

7.1 General

Sampling is defined as all steps required to obtain a representative sample of the contents of any pipe, tank or other system and to place the sample in the laboratory test container.

7.2 Laboratory sample

Only representative samples obtained as specified in ISO 3170 and ISO 3171 shall be used in this International Standard.

The size of the test portion shall be based on the expected water content of the sample, such that the water yield does not exceed the capacity of the trap, unless a trap with a stopcock is used, since excess water can then be withdrawn into a graduated cylinder.

7.3 Preparation of the test samples

The following sample-handling procedures shall apply in addition to those covered in ISO 3170 and ISO 3171.

7.3.1 Solid samples which are sufficiently brittle shall be crushed and mixed thoroughly. A representative test portion shall be drawn from the crushed and mixed samples.

7.3.2 Liquid samples shall be mixed, after warming, if necessary, in the original container. The mixing time, mixing power (speed) and height above the bottom of the container shall be satisfactory for the product being analysed as established in the procedure given in annex A. The volume and water content of the sample shall not exceed the maximum validated in annex A.

NOTE If there is any doubt about the homogeneity of the mixed samples prepared in 7.3.1 or 7.3.2, determinations should be made on the total volume of the sample if the sample size is compatible with the expected water content. If this is not possible, a determination should be made on at least three test portions. All these results should be included in the test report and their average should be recorded as the water content of the sample.

8 Procedure

8.1 Homogenize the sample in accordance with 7.3 before taking the test portion.

8.2 Measure the required test portion to an accuracy of $\pm 1\%$ and transfer it to the still in accordance with 8.3 or 8.4, depending on the sample type.

8.3 Measure mobile liquid samples in a graduated cylinder of an appropriate size. Rinse the material adhering to the cylinder with one 50 ml and two 25 ml portions of the solvent-carrier liquid (see clause 4 and Table 3). Drain the cylinder thoroughly after the sample transfer and each rinsing.

Table 3 — Type of solvent-carrier liquid versus material to be tested

Type of solvent-carrier liquid	Material
Aromatic	Bitumen, coal tars, preparations from bitumen and coal tars excluding emulsions.
Petroleum distillate	Road oil, fuel oil, lubricating oil, petroleum sulfonates.
Paraffinic	Lubricating grease.

8.4 Weigh solid or viscous materials directly into the still and add 100 ml of the selected solvent-carrier liquid (see Table 3). When testing material of low water content where large test portions are necessary, a solvent-carrier liquid volume in excess of 100 ml may be used.

8.5 A magnetic stirrer has been found to be most effective, but glass beads or other boiling aids may be added, if necessary, to reduce bumping.

8.6 Assemble the components of the apparatus as illustrated in Figures 1 and 2, choosing the trap in accordance with the expected water content of the sample and making all connections vapour- and liquid-tight. If a metal still with a removable cover is used, insert a gasket of heavy paper, moistened with solvent, between the body and the cover of the still. The condenser tube and trap shall be chemically clean to assure free drainage of water into the bottom of the trap. Insert a loose cotton plug in the top of the condenser to prevent condensation of atmospheric moisture inside it. Circulate cold water through the jacket of the condenser.

8.7 Apply heat to the still, adjusting the rate of boiling so that condensed distillate discharges from the condenser at a rate of 2 drops per second to 9 drops per second. If the metal still is used, start heating with the ring burner approximately 75 mm above the bottom of the still and gradually lower the burner as the distillation proceeds. Continue the distillation until no water is visible in any part of the apparatus except in the trap, and the volume of water in the trap remains constant for 5 min. If there is a persistent ring of water in the condenser tube, carefully increase or cut off the condenser water for a few minutes.

8.8 When the evolution of water is complete, allow the trap and contents to cool to room temperature. Dislodge any drops of water adhering to the sides of the trap with a glass rod, or by other suitable means, and transfer them to the water layer. Read the volume of the water in the trap to the nearest scale division.

8.9 Whenever a new solvent batch is used, a solvent blank shall be established by placing the volume of the solvent to be used during the actual determinations in the distillation flask and testing as outlined in 8.5 to 8.8.

9 Calculation

Calculate the water in the sample, φ as a percentage (volume/volume), or w as a percentage (mass/mass), in accordance with the basis on which the sample was taken as follows:

$$\varphi = \frac{V_1 - V_2}{V_0} \times 100 \quad (1)$$

$$\varphi = \frac{V_1 - V_2}{m/\rho} \times 100 \quad (2)$$

$$w = \frac{V_1 - V_2}{m} \times 100 \quad (3)$$

where

V_0 is the volume of the test portion, in millilitres;

V_1 is the volume of water, in millilitres, in the trap when the measurement is made on the unknown sample;

V_2 is the volume of water, in millilitres, in the trap when the measurement is made on the solvent blank;

m is the mass of test sample, in grams;

ρ is the density of sample, in grams per millilitre at 15 °C.

It is assumed that the density of water is 1 g/ml.

NOTE Volatile water-soluble material, if present, is measured as water.

10 Expressions of results

Report the result as the water content to the nearest 0,05 % if the 2 ml trap has been used, and to the nearest 0,1 % if the 10 ml or 25 ml traps have been used with a 100 ml or 100 g sample.

11 Precision

The criteria described in 11.1 and 11.2 shall be used to judge the acceptability of results (95 % probability) when using the 10 ml or 25 ml traps. The precision when using the 2 ml trap has not been established.

11.1 Repeatability

The difference between two test results, obtained by the same operator with the same apparatus under constant operating conditions on identical test material would, in the long run, in the normal and correct operation of the test method, exceed the values given in Table 4 in only one case in 20.

11.2 Reproducibility

The difference between two single and independent test results, obtained by different operators working in different laboratories on identical test material would, in the long run, in the normal and correct operation of the test method, exceed the values given in Table 4 in only one case in 20.

Table 4 — Precision

Values in millilitres

Water collected	Repeatability	Reproducibility
0,0 to 1,0	0,1	0,2
1,1 to 25	0,1 ml or 2 % of the mean, whichever is greater	0,2 ml or 10 % of the mean, whichever is greater

12 Test report

The test report shall contain at least the following information:

- a) a reference to this International Standard;
- b) the type and complete identification of the product tested;
- c) the result of the test (see clause 10);
- d) any deviation, by agreement or otherwise, from the procedure specified;
- e) the date of the test.

Annex A (normative)

Sample handling

A.1 General

A.1.1 The methods of handling samples between the point at which they are extracted or drawn, and the laboratory test bench or sample storage, are devised to ensure that the nature and integrity of the sample be maintained.

A.1.2 The method of handling a sample will depend on the purpose for which it has been taken. The laboratory analytical procedure to be used will often require a special handling procedure to be associated with it. For this reason, consult the appropriate test methods so that any necessary instructions as to sample handling can be given to the person drawing the sample. If the analytical procedures to be applied have conflicting requirements, draw separate samples and apply the appropriate procedure to each sample.

A.1.3 Take particular care in respect of the following:

- a) liquids containing volatile material, since loss by evaporation can occur;
- b) liquids containing water and/or sediment, since separation tends to occur in the sample container;
- c) liquids with potential wax deposition, since deposition can occur if a sufficient temperature is not maintained.

A.1.4 When making up composite samples, take great care not to lose light ends from volatile liquids and not to alter water and sediment content. This is a very difficult operation and should be avoided if at all possible.

A.1.5 Do not transfer samples of volatile liquids to other containers at the sampling location but transport them to the laboratory in the original sample container, cooled and inverted, if necessary. Great care is necessary if a sample contains both volatile components and free water.

A.2 Homogenization of samples

A.2.1 Introduction

Procedures are specified for the homogenization of samples that may contain water and sediment, or are in any other way non-uniform, before transfer from the sample container to smaller containers or into laboratory test apparatus. Procedures for verifying that the sample is satisfactorily mixed before transfer are given in clause A.3.

It is not possible to manually agitate small samples of liquids containing water and sediment enough to disperse the water and sediment within the sample. Vigorous mechanical or hydraulic mixing is necessary in order to homogenize the sample prior to transfer or sub-sampling.

Homogenization may be accomplished by various methods. Whichever method is used, it is recommended that the homogenizing system produces water droplets below 50 µm, but not less than 1 µm. Water droplets of below 1 µm will give a stable emulsion and the water content cannot then be determined by centrifuge methods.

A.2.2 Homogenization by a high-shear mechanical mixer

Insert a high-shear mechanical mixer into the sample container so that the rotating element reaches to within 30 mm of the bottom. A mixer with counter-rotating blades operating at approximately 3 000 r/min (50 s⁻¹) is usually suitable. Other designs may be used if the performance is satisfactory.

Record the temperature of the sample before mixing. In order to minimize loss of light ends from crude oils or other samples containing volatile compounds, operate the stirrer through a gland in the closure of the sample container. Mix until the sample is completely homogenized.

NOTE 1 A mixing time of 5 min is sometimes sufficient, but the size of the container and the nature of the sample affect the homogenization time.

Record the temperature of the sample immediately after mixing. If the rise in temperature during mixing exceeds 10 °C, cool the sample, and repeat the mixing at a lower energy input.

NOTE 2 A rise in temperature of greater than 10 °C may result in a decrease in viscosity sufficient for the sediment to settle.

Verify that the sample has become homogeneous (see clause A.3).

NOTE 3 High-shear mixers frequently produce stable emulsions and water contents after stirring that cannot be determined by centrifuge methods.

A.2.3 Circulation with external mixer

By means of a small pump, circulate the contents of either permanently sited or portable containers through a static mixer installed externally in small-bore piping. For portable containers, use a quick-disconnect coupling. Follow the manufacturer's instructions for the operation of the specific pump design and capacity chosen.

Use a circulating flow rate sufficient to circulate the contents at least once per minute.

NOTE A typical mixing time is 15 min, but this will vary according to the water content, the type of hydrocarbon and the design of the system.

When the whole sample is thoroughly mixed, run off the required quantity of subsample from a valve in the circulating line, whilst the pump is running. Then empty the container and thoroughly clean the entire system by pumping solvent round until all traces of the hydrocarbon have been removed.

A.3 Verification of mixing time

A.3.1 If the sample remains homogeneous and stable after mixing (e.g. where completely miscible components such as lubricant additives have been blended), continue the mixing procedure until successive samples drawn from the main bulk of the sample give identical results. This establishes the minimum mixing time.

NOTE As the sample is, by this time, homogenous and will remain so, transfers from the main bulk can be made without further mixing.

A.3.2 If the sample does not remain homogeneous for more than a short period of time after mixing (e.g. if water and sediment are part of the mixture) use the special method for the verification of mixing time described in A.3.3.

NOTE It may be necessary, owing to the characteristics of the hydrocarbon, to subsample while mixing is still in progress.

A.3.3 Ensure that the sample as drawn fills the container to approximately three-quarters full, and homogenize the sample for a known period of time, which shall be recorded. During this period, draw off small portions at regular intervals and test each immediately for water content in accordance with a suitable standard method (see A.3.4). When the test results are consistent, record the value obtained as the blank water content.

Add an accurately measured quantity of water, between 1 % and 2 %, and homogenize for the same period of time as for the blank. Then take samples as before. If there is good agreement between the water content determined, taking account of the blank water content, and the quantity of water added then repeat by adding a further accurately measured quantity of water, again between 1 % and 2 %. If the results continue to give good agreement then assume that the mixing time is adequate.

If the results do not show good agreement (within the repeatability of the method), discard them. Revert to the beginning of the procedure, and use a longer period of mixing.

A.3.4 Do not determine water content by the centrifuge method (ISO 3734:1997, *Petroleum products — Determination of water and sediment in residual fuel oils — Centrifuge method*) for this verification of the mixing system, as this method does not determine the total water content.

A.4 Transfer of samples

A.4.1 If the sample container is not portable, or if it is inconvenient to take samples directly from the container into laboratory test apparatus, transfer a representative sample into a portable container for transport to the laboratory.

A.4.2 At every stage of transfer of a sample, it is essential to homogenize the contents of the container from which the sample is being taken using one of the methods specified in clause A.2.

A.4.3 Verify the mixing time for each combination of container and mixer by one of the methods specified in clause A.3.

A.4.4 Complete any transfer of sample within the period during which the mixture is known to be homogeneous and stable. This period is short; do not take longer than 20 min to complete any transfer.

www.iso.org

ICS 75.080

Price based on 13 pages
