**Industrial trucks — Safety
requirements and verification —**

**Part 6:
Burden and personnel carriers**

*Chariots de manutention — Exigences de sécurité et vérification —
Partie 6: Transporteurs de charges et de personnel*





COPYRIGHT PROTECTED DOCUMENT

© ISO 2013

All rights reserved. Unless otherwise specified, no part of this publication may be reproduced or utilized otherwise in any form or by any means, electronic or mechanical, including photocopying, or posting on the internet or an intranet, without prior written permission. Permission can be requested from either ISO at the address below or ISO's member body in the country of the requester.

ISO copyright office
Case postale 56 • CH-1211 Geneva 20
Tel. + 41 22 749 01 11
Fax + 41 22 749 09 47
E-mail copyright@iso.org
Web www.iso.org

Published in Switzerland

Contents

Page

Foreword	iv
Introduction	v
1 Scope	1
2 Normative references	1
3 Terms and definitions	2
4 Safety requirements and/or protective measures	3
4.1 General.....	3
4.2 Starting/moving.....	3
4.3 Brakes.....	4
4.4 Manual control actuators.....	4
4.5 Power systems and accessories.....	7
4.6 Operator and passenger positions.....	10
4.7 Stability.....	12
4.8 Protective devices.....	12
4.9 Visibility/lighting.....	13
4.10 Environmental conditions.....	14
4.11 Transport.....	15
5 Verification of safety requirements and/or protective measures	15
5.1 General.....	15
5.2 Functional verification.....	15
6 Information for use	16
6.1 General.....	16
6.2 Instruction handbook(s).....	16
6.3 Marking.....	19
Annex A (informative) List of significant hazards	21
Bibliography	26

Foreword

ISO (the International Organization for Standardization) is a worldwide federation of national standards bodies (ISO member bodies). The work of preparing International Standards is normally carried out through ISO technical committees. Each member body interested in a subject for which a technical committee has been established has the right to be represented on that committee. International organizations, governmental and non-governmental, in liaison with ISO, also take part in the work. ISO collaborates closely with the International Electrotechnical Commission (IEC) on all matters of electrotechnical standardization.

The procedures used to develop this document and those intended for its further maintenance are described in the ISO/IEC Directives, Part 1. In particular the different approval criteria needed for the different types of ISO documents should be noted. This document was drafted in accordance with the editorial rules of the ISO/IEC Directives, Part 2. www.iso.org/directives

Attention is drawn to the possibility that some of the elements of this document may be the subject of patent rights. ISO shall not be held responsible for identifying any or all such patent rights. Details of any patent rights identified during the development of the document will be in the Introduction and/or on the ISO list of patent declarations received. www.iso.org/patents

Any trade name used in this document is information given for the convenience of users and does not constitute an endorsement.

For an explanation on the meaning of ISO specific terms and expressions related to conformity assessment, as well as information about ISO's adherence to the WTO principles in the Technical Barriers to Trade (TBT) see the following URL: http://www.iso.org/iso/home/standards_development/resources-for-technical-work/foreword.htm

The committee responsible for this document is ISO/TC 110, *Industrial trucks*, Subcommittee SC 2, *Safety of industrial trucks*.

This first edition of ISO 3691-6, together with ISO 3691-1, ISO 3691-2, ISO 3691-3, ISO 3691-4, ISO 3691-5, ISO/TS 3691-7 and ISO/TS 3691-8, cancels and replaces ISO 3691:1980, of which it constitutes a technical revision.

ISO 3691 consists of the following parts, under the general title *Industrial trucks — Safety requirements and verification*:

- *Part 1: Self-propelled industrial trucks, other than driverless trucks, variable-reach trucks and burden-carrier trucks*
- *Part 2: Self-propelled variable-reach trucks*
- *Part 3: Additional requirements for trucks with elevating operator position and trucks specifically designed to travel with elevated loads*
- *Part 4: Driverless industrial trucks and their systems*
- *Part 5: Pedestrian-propelled trucks*
- *Part 6: Burden and personnel carriers*
- *Part 7: Regional requirements for countries within the European Community [Technical Specification]*
- *Part 8: Regional requirements for countries outside the European Community [Technical Specification]*

Introduction

This document is a type-C standard as stated in ISO 12100.

The machinery concerned and the extent to which hazards, hazardous situations or hazardous events are covered are indicated in the Scope of this document.

When requirements of this type-C standard are different from those which are stated in type-A or B standards, the requirements of this type-C standard take precedence over the requirements of the other standards for machines that have been designed and built according to the requirements of this type-C standard.

The ISO 3691 series of standards covers safety requirements and their verification for industrial trucks as defined in ISO 5053.

Structure

An important step forward in the work on the ISO 3691 series of standards was the agreement to issue a new structure of International Standards for industrial trucks having on one side basic standards for all kinds of trucks (see Foreword) and on the other side independent standards to cover the respective specific functions of industrial trucks, e.g. visibility, noise, vibration, electrical requirements, etc.

Assessment of hazards

The product needs to be designed in such a way that it is fit for its purpose or function and can be adjusted and maintained without putting persons at risk when used under the conditions foreseen by the manufacturer.

In order to properly design a product and to cover all specific safety requirements, the manufacturer will have to identify the hazards that apply to his product and carry out a risk assessment. The manufacturer will then need to design and construct the product taking this assessment into account.

The aim of this procedure is to eliminate the risk of accidents throughout the foreseeable lifetime of the machinery, including the phases of assembling and dismantling where risks of accidents could also arise from foreseeable abnormal situations.

In selecting the most appropriate methods, the manufacturer will need to apply the following principles, in the order given here:

- a) eliminate or reduce risks as far as possible by design (inherently safe machinery design and construction);
- b) take the necessary protective measures in relation to risks that cannot be eliminated by design;
- c) inform users of any shortcoming of the protective measures adopted;
- d) indicate whether any particular training is required;
- e) specify any need to provide personal protection equipment;
- f) refer to the appropriate user's document for proper operating instructions.

Industrial trucks need to be designed to prevent foreseeable misuse wherever possible, if such would engender risk. In other cases, the manufacturer's instructions will need to draw the user's attention to ways shown by experience in which the machinery ought not to be used.

This part of ISO 3691 does not repeat all the technical rules which are state-of-the-art and which are applicable to the material used to construct the industrial truck. Reference will also need to be made to ISO 12100.

Legislative situation/Vienna Agreement

From the very beginning, the task of the working group was to revise ISO 3691:1980 and establish worldwide basic standards to comply with the major legislative regulations in, for example, the EU, Japan, Australia and North America.

Every effort was made to develop a globally relevant International Standard. That goal was achieved with most of the issues. For several potential problem areas compromises were needed and will be needed in the future. Where divergent regional requirements remain, these are addressed by ISO/TS 3691-7 and ISO/TS 3691-8.

In order to ensure that the revised International Standard will be actively used in the ISO member countries, worldwide, procedures are necessary to replace the existing national standards and technical regulations by the revised International Standard. In the European Community, ISO and the European Committee for Standardization (CEN) agreed on technical co-operation under the Vienna Agreement, with the aim of replacing European Standards (EN) by International Standards. Other countries are asked to make similar agreements to ensure that their national standards and technical regulations are replaced by this International Standard.

Only by these actions will there be the guarantee that products in accordance with International Standards can be shipped worldwide freely without any technical barriers.

Industrial trucks — Safety requirements and verification —

Part 6: Burden and personnel carriers

1 Scope

This part of ISO 3691 gives safety requirements and the means for their verification for self-propelled carriers designed for carrying burdens without lifting, as defined in ISO 5053, and/or personnel carriers, having three or more wheels, a maximum speed not exceeding 56 km/h and a load capacity not exceeding 5 000 kg (hereafter referred to as *carriers* or *trucks*).

This part of ISO 3691 is applicable to trucks equipped with a platform (which can be tilting) for the purpose of carrying materials or with a number of seats for the purpose of transporting passengers.

It is not applicable to

- vehicles intended primarily for earth-moving or over-the-road hauling,
- driverless trucks,
- golf cars,
- tractors with a drawbar pull up to and including 20 000 N equipped with a platform for the purpose of carrying materials.

This part of ISO 3691 deals with all significant hazards, hazardous situations or hazardous events, as listed in [Annex A](#), relevant to the applicable machines when used as intended and under conditions of misuse which are reasonably foreseeable by the manufacturer.

It does not establish requirements for hazards that can occur when using trucks on public roads or when operating in potentially explosive atmospheres.

Regional requirements, additional to the requirements given in this part of ISO 3691, are addressed in ISO/TS 3691-7 and ISO/TS 3691-8.

2 Normative references

The following documents, in whole or in part, are normatively referenced in this document and are indispensable for its application. For dated references, only the edition cited applies. For undated references, the latest edition of the referenced document (including any amendments) applies.

ISO 2867:2011, *Earth moving machinery — Access systems*

ISO 3287:1999, *Powered industrial trucks — Symbols for operator controls and other displays*

ISO 3411:2007, *Earth-moving machinery — Physical dimensions of operators and minimum operator space envelope*

ISO 3795:1989, *Road vehicles, and tractors and machinery for agriculture and forestry — Determination of burning behaviour of interior materials*

ISO 5010:2007, *Earth-moving machinery — Rubber-tyred machines — Steering requirements*

ISO 3691-6:2013(E)

ISO 5053, *Powered industrial trucks — Terminology*

ISO 6292:2008, *Powered industrial trucks and tractors — Brake performance and component strength*

ISO 12100:2010, *Safety of machinery — General principles for design — Risk assessment and risk reduction*

ISO 13564-1:2012, *Powered industrial trucks — Test methods for verification of visibility — Part 1: Sit-on and stand-on operator trucks and variable-reach trucks up to and including 10 t capacity*

ISO 13849-1:2006, *Safety of machinery — Safety-related parts of control systems — Part 1: General principles for design*

ISO 15870:2000, *Powered industrial trucks — Safety signs and hazard pictorials — General principles*

ISO 20898:2008, *Industrial trucks — Electrical requirements*

ISO 21281:2005, *Construction and layout of pedals of self-propelled sit-down rider-controlled industrial trucks — Rules for the construction and layout of pedals*

ISO 24135-1:2006, *Industrial trucks — Specifications and test methods for operator restraint systems — Part 1: Lap-type seat belts*

ANSI/ITSDF B56.8:2006, *Safety Standard for Personnel and Burden Carriers*¹⁾

3 Terms and definitions

For the purposes of this document, the terms and definitions given in ISO 5053 and ISO 12100 and the following apply.

3.1 burden [personnel] carrier

mobile power-driven machine that is not self-loading, used for transporting material and/or personnel on indoor and outdoor improved surfaces, but not for use on public roads

3.2 operator

designated person, trained and authorized, who is responsible for the movement and operation of the carrier and, depending on the carrier type, can be transported by the carrier, or can be on foot accompanying the truck or can be remote from the truck (remote-controlled by cables, radio, etc.)

3.3 normal operating position

position in which the operator is able to control all functions for driving as defined by the manufacturer

3.4 load capacity

maximum load, including the operator and passengers

3.5 capacity

operator and number of passengers permitted by the manufacturer

1) American National Standards Institute/Industrial Truck Standards Development Foundation.

4 Safety requirements and/or protective measures

4.1 General

4.1.1 Overall requirements

Trucks shall comply with the safety requirements and/or protective measures of this clause. In addition, the truck shall be designed according to the principles of ISO 12100 for relevant but not significant hazards which are not dealt with by this document.

4.1.2 Normal climatic conditions

For truck operation, the following climatic conditions apply:

- average ambient temperature for continuous duty: +25 °C
- maximum ambient temperature, short term (up to 1 h): +40 °C
- lowest ambient temperature for trucks intended for use in normal indoor conditions: +5 °C
- lowest ambient temperature for trucks intended for use in normal outdoor conditions: -20 °C
- altitude: up to 2 000 m

4.1.3 Electrical requirements

Electrical systems and equipment shall be in accordance with ISO 20898, except where regional requirements apply. See ISO/TS 3691-7 and ISO/TS 3691-8.

4.1.4 Edges and angles

There shall be no sharp edges or angles posing a hazard in the area of the operator in the normal operating position or in the area of access and egress of operators or passengers and during normal operation and daily checks.

4.1.5 Stored energy components

Components which store energy and would cause a risk during removal or disassembly, e.g. hydraulic accumulator or spring applied brakes, shall be provided with a means of releasing the energy before removal or disassembly.

4.2 Starting/moving

4.2.1 Unauthorized starting

Carriers shall be provided with a device (e.g. a key, a code, a magnetic card) that prevents starting without that device.

4.2.2 Unintended movement

4.2.2.1 Parking brake

A parking brake shall be provided complying with [4.3.1](#).

4.2.2.2 Internal combustion engine-powered carriers

Internal combustion engine-powered carriers shall be fitted with a device that prevents the engine being started while the transmission is engaged.

4.2.2.3 Travel controls

Travel controls on internal combustion engine powered carriers shall be so arranged that on level ground the carrier will not move from rest until the transmission has been engaged.

4.2.2.4 Powered travel movement

Powered travel movement of the carrier with a ride-on operator shall be possible only if the operator is in the normal operating position.

Powered travel shall not occur automatically when the operator returns to the normal operator position(s) without an additional operation, e.g. by requiring resetting the direction control or reactivating speed control, etc.

4.2.2.5 Manual gearbox and manually operated clutch pedal

A carrier with an automotive-type manual gearbox and manually operated clutch pedal satisfies the requirements of [4.2.2.2](#) and [4.2.2.4](#).

4.2.3 Speedometer

A speedometer shall be provided on ride-on carriers that have a maximum travel speed greater than 25 km/h.

4.3 Brakes

4.3.1 General

All carriers shall be designed with service and parking brakes complying with ISO 6292. The parking brake shall be equipped with a system preventing unintentional release.

Emergency braking is subject to regional requirements, additional to the requirements of this part of ISO 3691. See ISO/TS 3691-7 and ISO/TS 3691-8.

4.3.2 Stand-on carriers

Stand-on carriers shall be equipped with a brake system that will automatically engage upon release of the brake actuating control by the operator. This system may serve as the service and parking brake.

4.3.3 Failure of the energy supply

Failure of the energy supply for the brake release shall not result in loss of braking for automatically acting brakes. The brake shall be automatically applied in the event of failure of energy supply to this brake system.

4.4 Manual control actuators

4.4.1 General

4.4.1.1 Consistency with the carrier motions

Movement of these controls, where practicable, shall be consistent with the carrier motions being operated. They shall be confined within the plan view outline of the carrier or tiller.

4.4.1.2 Multiple operators

If additional operating positions are fitted, i.e. more than one operator, the operation of these controls shall only be possible from one operating position at a time, excepting the emergency disconnect switch, which shall be operable from all positions.

4.4.1.3 Multiple operating positions

If more than one operating position is fitted for a single operator, the use of the controls of one operating position shall preclude the use of the controls of other operating positions, excepting the emergency disconnect switch, which shall be operable from all positions.

4.4.2 Travel and braking controls

4.4.2.1 General

The motion of the speed operating control shall be designed such that an increase in the movement of the control increases the travel speed. When the control is released, it shall return to the neutral position of the control actuator.

4.4.2.2 Sit-on carriers

Pedal operated travel and braking controls shall comply with ISO 21281.

4.4.2.3 Differential locking

For carriers fitted with a pedal-operated differential lock, depression of the pedal shall lock the differential and it shall be unlocked by releasing the pedal. It shall be possible to unlock the differential when the truck is moving.

4.4.2.4 Hand-operated direction control lever

The movement of a direction control lever shall correspond to the selected direction of travel.

4.4.2.5 Hand-operated accelerator control lever

The control lever shall be a hold-to-run control. It shall return to the neutral position when released. Movement towards the front of the carrier or away from the operator shall increase speed.

4.4.2.6 Additional operation from outside the carrier

4.4.2.6.1 General

If travel control from outside the carrier is provided for the operator, the travel speed shall be limited to 6 km/h. These controls can be attached to the carrier or remote control can be provided. This operating system can be made operable by means of a separate switch or automatically when the operator leaves the normal operating position.

4.4.2.6.2 Security

If the control actuator is released, the drive unit shall switch off automatically and the brake shall be engaged. Simultaneous operation from the operating positions shall be excluded.

4.4.2.6.3 Additional requirements for cable-connected remote control

Length and layout of the cables shall allow the operator to operate from outside of the area of hazard of the truck and have visibility of the path of travel. It shall not be possible for the cable to become entangled with the wheels.

On a portable control panel, the control elements, with the exception of the emergency stop, shall be guarded against unintentional operation.

4.4.2.6.4 Additional requirements for cableless control

The transmission range shall be adequate for the operator to operate from outside the area of hazard of the truck and have visibility in the path of travel.

On the portable control panel, the control elements for movement, with the exception of the emergency stop, shall be guarded against unintentional operation.

The reliability level shall be at least 10^{-9} and the hamming distance shall be 2. The remote control shall meet the requirements of ISO 13849-1, performance level (PL) c.

In case of communication being lost, the brake system shall engage within 0,5 s.

No control interference shall be possible when more than one truck is operating under remote control at the same time.

4.4.2.6.5 Additional requirements for carriers with trailer coupling

The controls (e.g. rear touch device) shall be arranged such that the operator does not have to step between the carrier and the trailer to operate them.

The rear touch device shall be secured against unintentional operation.

When operating the rear touch device, the carrier shall travel at a speed of not more than 2,5 km/h.

4.4.3 Steering controls

4.4.3.1 Direction

Clockwise rotation of the steering wheel or any equivalent movement of the steering control shall steer the carrier to the right when driving forward.

For pedestrian-operated carriers fitted with a tiller, when travelling in the forward direction, clockwise movement of the tiller shall steer the carrier to the right.

4.4.3.2 Failure of power supply

In the event of an interruption of the power supplied to the steering system (including a dead motor or engine), it shall be possible to maintain the path being steered until the carrier is brought to a stop.

For carriers with a maximum travel speed above 20 km/h, the steering performance in the case of power supply shall comply with ISO 5010.

4.4.4 Marking

For marking, graphic symbols for controls shall comply with [6.3.2](#).

4.5 Power systems and accessories

4.5.1 Exhaust and cooling systems

4.5.1.1 Exhaust system

The exhaust system shall be designed in accordance with [4.6.4](#). The exhaust system shall be designed to direct engine exhaust away from the operator position. Materials used in the vicinity of exhaust systems shall not be flammable and shall be chosen and protected so that they are not adversely affected by heat from the exhaust system.

4.5.1.2 Cooling system

The air flow through the cooling system shall be arranged so as to avoid discomfort to the operator/passengers.

4.5.2 Fuel tank

4.5.2.1 Tank isolation

If a fuel tank is within or adjacent to the engine compartment and excessively high temperatures may occur, the tank and/or filling arrangement shall be isolated from the electrical and exhaust systems by suitable protection, e.g. a separate enclosure or baffles. The tank location and facilities for filling shall be such that spillage or leakage will not drain into the engine or operator's compartment or onto electrical or exhaust system parts.

4.5.2.2 Fuel spillage

Fuel spillage shall not be possible under normal operating conditions.

4.5.3 Access to engine and other compartments

4.5.3.1 Engine cover

An enclosed engine compartment shall satisfy fan guarding requirements when the manufacturer's recommended routine maintenance is performed with the engine off. If a fan can start (e.g. temperature switch) when the engine is off, the fan shall be guarded. A safety warning sign shall be provided, and included in the operator's handbook. Warnings shall comply with [6.3.3.4](#).

Access from underneath is considered guarded if the access ground clearance is less than 600 mm between the underside of the truck and level ground.

4.5.3.2 Unintentional closure

Where unintentional closure could cause injury, access covers (i.e. traction battery or engine covers) shall be provided with means of preventing unintentional closure.

4.5.4 Liquefied petroleum gas (LPG) carriers

LPG-powered trucks are subject to regional requirements, additional to the requirements of this part of ISO 3691. See ISO/TS 3691-8.

4.5.4.1 Containers

The following applies to the containers of trucks powered by LPG.

- a) LPG containers shall be either permanently fixed to the truck or removable.

- b) When LPG containers are removable, their fastenings shall permit easy handling and checking of the installation after the exchange of containers.
- c) Removable LPG containers that incorporate a pressure relief valve shall be so positioned on the truck that the pressure relief valve opening is always in communication with the vapour space at the top of the container. This may be accomplished, for example, by an indexing pin which positions the container when the container is properly installed.
- d) LPG containers shall be securely mounted to the truck to prevent movement. Fastening shall withstand static loading of four times the filled container weight in any direction without permanent visible deformation.
- e) LPG containers shall be fitted on the truck such that exposure to abrasion, shock and the corrosive action of the products handled by the truck is reduced.
- f) LPG containers and their connections shall be installed such that there are no projections outside the plan view outline of the truck.
- g) If LPG containers are installed in a compartment, this compartment shall have permanent openings at the bottom. The total surface area of these ventilation openings shall be at least 200 cm² allowing adequate ventilation to outside the truck.
- h) If an additional LPG container is carried on the truck, it shall be secured in the same manner as the main container.
- i) LPG containers, whether fixed or removable, shall be equipped with a device to prevent unintentional emission of gas or liquid, e.g. in the case of a pipe system failure. This does not apply to pressure-relief valves.
- j) Pipe fittings and accessories on LPG containers shall be protected against mechanical damage when used as specified by the manufacturer.
- k) The fuel take-off on the LPG container shall be equipped with an easily and quickly accessible manually operated valve. The position and method of operation of this valve shall be clearly marked on the valve handle or on the outside of the truck near the valve.
- l) The fuel take-off shall be in a liquid form unless the LPG container and engine are specially equipped for a direct vapour withdrawal.
- m) Permanently mounted LPG containers to be filled by the user shall be fitted with the following:
 - a pressure relief valve connected to the vapour space of the container that, when fitted inside the compartments of trucks, shall have the discharge side of the relief valve piped to the atmosphere away from the operator and that shall comply with 4.5.4.3 d);
 - an 80 % fill stop valve;
 - maximum level indicating devices that rely on bleeding to the atmosphere designed such that the venting hole is no larger than 1,5 mm in diameter and that the parts of the device cannot be completely withdrawn in normal gauging operations;
 - maximum liquid level devices suitable for the LPG in use, indicating the maximum product level and which shall not vent to the atmosphere.
- n) LPG containers shall be positioned such that they are not exposed to the damaging effects of heat, particularly heat from the engine or the exhaust system. If it is necessary to fit a heat shield, this shall not inhibit ventilation.

4.5.4.2 Piping

The following applies to the piping used on trucks powered by LPG.

- a) Connecting piping and all associated parts shall be easily accessible, protected against excessive heat radiation, damage and wear, and shall be flexible enough to withstand vibration and deformation in service, as follows:
 - piping shall be so arranged that damage or leaks are easily detectable and that checks and maintenance can be carried out;
 - piping shall be installed such that it cannot be damaged by any excessive heat radiation from hot parts of the truck;
 - fully rigid pipes shall not be used for connecting the container to equipment on the engine;
 - piping shall be so arranged that there are no projections outside the plan view outline of the truck.
- b) Pressure hoses operating above 1 bar²⁾ shall be supported at least every 500 mm. Rigid pipes shall be supported at least every 600 mm.
- c) Hoses, pipes and all connections operating at pressures above 1 bar shall be suitable for a working pressure of 25 bar and shall withstand without bursting a test pressure of 75 bar. Hoses, pipes and all connections operating below 1 bar shall withstand without bursting a test pressure of five times the maximum working pressure.
- d) Pressure shall not exceed the working pressure rating of components in any section of pipe work containing LPG in liquid form between two shut-off valves that are closed; a pressure relief valve, for example, or other suitable means may be used if necessary.
- e) Aluminium piping shall not be used.
- f) Hoses shall be as short as practical.
- g) Pressure unions and joints operating above 1 bar shall be made of metal except for any constrained sealing washers.

4.5.4.3 Equipment

The following applies to the equipment used on trucks powered by LPG.

- a) The supply of gas shall be automatically cut off when the engine stops, irrespective of whether or not the ignition system has been switched off.
- b) For multi-fuel applications, the system shall be designed to avoid the possibility of LPG entering any other fuel container and to shut off each fuel source before the alternative one is opened.
- c) If the truck is equipped with two or more containers to supply fuel, they shall be connected via a multi-way valve or other suitable means, so that LPG can only be drawn from one container at a time. The use of two or more containers at the same time shall not be possible.
- d) Pressure-relief valves or liquid-level indicators shall be installed such that they cannot discharge in the direction of the operator or onto truck components that could be a source of ignition.
- e) If corrosion of a part would interfere with its proper functioning, that part shall be provided with a corrosion-resistant protective coating.
- f) All fuel system components shall be firmly secured to the truck.
- g) Pressure-reducing valves shall be readily accessible for inspection and maintenance.

2) 1 bar = 0,1 MPa = 0,1 N/mm² = 10⁵ N/m².

- h) The engine compartment shall be designed in accordance with 4.5.4.1 g), in order to avoid any LPG accumulation.

4.6 Operator and passenger positions

4.6.1 Dimensions

The operator’s seat or standing position shall be so located that the operator, while operating the carrier, has enough room to stay within the plan view outline of the carrier. The dimensions shall be of suitable ergonomic shape to accommodate at least a 5th percentile to a 95th percentile of the population as defined in ISO 3411:2007, Figures 1 to 4, within the plan view outline of the carrier. The seat shall not extend beyond the plan view outline of the carrier.

The minimum distance from the top edge of the seat back to the plan view outline of the carrier shall be 50 mm (see [Figures 1](#) and [2](#)).

For stand-on pedestrian and centre controlled ride-on carrier, the tiller steering control in the normal operating position may extend beyond the plan view

Dimensions in millimetres

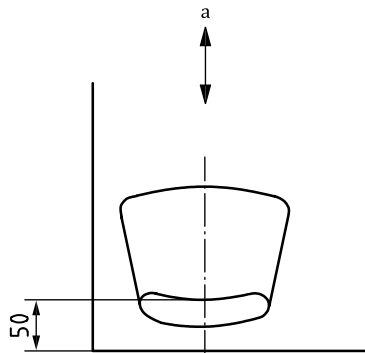

- a Direction of travel.

Figure 1 — Minimum distance — Front-seated operator

Dimensions in millimetres

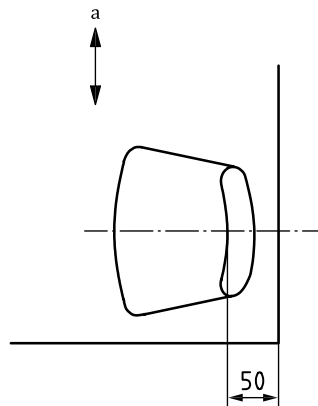

- a Direction of travel.

Figure 2 — Minimum distance — Side-seated operator

4.6.2 Compartment floor

The compartment floor frequented by the operator and passengers shall have a slip-resistant surface, e.g. ribbed mats, abrasive coating, etc.

4.6.3 Seats

4.6.3.1 Operator's seat

The seat shall be designed and located so as to provide easy access to the controls, a position for the carrier operator following ergonomic principles and shall fulfil the following requirements:

- a) if the seat has a facility allowing fore and aft adjustment this shall be possible without using tools;
- b) if a weight-adjustable seat is fitted to reduce vibration transmitted to the operator, the adjustment shall accommodate operator weights of 55 kg to 110 kg; manual adjustment of the weight mechanism shall be possible without using tools;
- c) if a seat has a facility allowing it to swivel about a vertical axis, this shall be possible at all seat adjustment positions without unintentional operation of controls and it shall be firmly locked at each operating position;
- d) the seat mounting shall withstand the forces that may occur during operation e.g. braking forces as well as the force brought about by the operator restraint system defined in [4.6.3.3](#).

The operator's seat is subject to regional requirements, additional to the requirements of this part of ISO 3691. See ISO/TS 3691-7 and ISO/TS 3691-8.

4.6.3.2 Passenger seats

Seats shall be provided for each intended passenger. The seat mounting shall withstand the forces that may occur during operation (e.g. braking forces).

4.6.3.3 Restraints and handholds

Sit-down rider carriers that can travel at speeds greater than 25 km/h shall be provided with seat(s) with hip restraints. Handholds shall be provided for the operator and each passenger. The restraint device shall be in accordance with ISO 24135-1. A steering wheel or two-hand tiller shall be considered a handhold for the operator. A handhold shall be provided for each additional intended passenger and placed in such a manner that when grasping the hand-hold, the passenger's hands will be within the plan view outline of the carrier.

4.6.3.4 Protection from road wheels and objects thrown up

The operator in the normal operating position and the passengers shall be protected against contact with the carrier road wheels and against objects thrown up by the wheels (e.g. mud, gravel, bolts, etc.). The protection device for the steered wheels need only cover the wheels when in a straight line position.

4.6.3.5 Platform

Operator's stand-on platforms, on pedestrian-controlled carriers or rider-controlled carriers capable of travelling more than 6 km/h shall be provided with guards at the sides or outside edge of the platform when the operator's stand-on platforms overhang the carrier chassis. The guards shall be capable of withstanding a horizontal force of 900 N acting from inside to outside applied in line with the centre of the operator's standing position at a height of 900 mm from the platform without permanent deflection.

4.6.4 Protection from burning

All parts of the carrier within reach of the operator in the normal operating position and passengers in the normal seated position or when getting into or leaving the normal operating or seated position shall be insulated or shielded if necessary, so that the surface temperature generated by heat sources in the carrier of bare metal parts does not exceed 65 °C and that of painted or plastic parts does not exceed 83 °C. The temperature of the air at the heater outlet, where fitted, shall not exceed 60 °C.

Protection from burning is subject to regional requirements, additional to the requirements of this part of ISO 3691. See ISO/TS 3691-7.

4.6.5 Protection against crushing, shearing and trapping

Parts that move relative to one another and which are within the reach of the operator when in the normal operating position on loading/unloading, or within reach of passengers when seated, shall be adequately guarded or be separated by the following minimum distance:

- places where fingers can be trapped 25 mm;
- places where hands or feet can be trapped 50 mm;
- places where arms and legs can be trapped 100 mm.

Relative moving parts that need to contact or move in close proximity to one another shall be guarded. Any openings in this guarding shall be small enough to prevent an 8 mm diameter probe from passing through them. If hazards still exist, they shall be identified on the carrier in accordance with [6.3.3.4](#).

Fixed guards and their mounting systems are subject to regional requirements, additional to the requirements of this part of ISO 3691. See ISO/TS 3691-7 and ISO/TS 3691-8.

4.7 Stability

In order to minimize the hazards of exceeding the overturning moment of a carrier, the carrier shall be in accordance with ANSI/ITSDF B56.8:2006, 9.4, for the respective tests without permanent deformation.

4.8 Protective devices

4.8.1 Warning device

Carriers shall be equipped with an operator-controlled audible warning device.

4.8.2 Devices for towing

Carriers used for towing trailers shall be fitted with towing or coupling devices designed, constructed and arranged so as to reduce hazards during connection and disconnection and to prevent accidental disconnection during use.

Levers and handles shall be designed such that in every possible position there is a safety spacing of at least 25 mm from other parts of the trailer coupling and from adjacent parts of the carrier.

4.8.3 Wheels with split wheel rims for inflatable tyres

When split wheels are used with pneumatic tyres, the carrier shall be provided with devices and information on their proper use to prevent the user from separating the halves of the wheel before removing the wheel from the axle.

4.8.4 Battery restraint devices

On battery-powered carriers, means shall be provided to restrain the battery from moving more than 15 mm in a horizontal direction.

In addition, where the displacement of the traction battery may pose a risk of injury to the operator and/or passengers due to a tip-over — a battery-restraint device(s) shall restrict the battery displacement to no more than 100 mm into the space normally occupied by the operator and/or passengers or from moving more than 100 mm in a lateral direction beyond the limits of the battery compartment. A tip-over may be simulated by allowing a static truck to fall free from its critical balance point impacting on a horizontal plane. A complete truck is not required for this test, but all battery compartment related parts shall be fitted. The movement of the battery shall not interfere with the operator's egress from the carrier.

The battery housing shall be constructed and located and the battery installed in such a way as to avoid electrolyte being spilled on the operator/passengers in the event of tip-over and/or such as to avoid the accumulation of vapours in places occupied by the operator/passengers.

The battery cover, if any, of a compartment that is an integral part of the carrier, or a separate enclosure such as a tray and cover, shall be secured.

4.8.5 Traction battery requirements

4.8.5.1 Unauthorized access

Facilities shall be provided on trucks with nominal battery voltage exceeding 120 V d.c. so that the battery compartment can be secured to prevent unauthorized access to the battery if a lockable cover is not present on the battery enclosure.

4.8.5.2 Battery compartment

Support and protection shall be provided for the battery by means of a compartment that is an integral part of the carrier or a separate enclosure, such as a tray and cover.

4.8.5.3 Compartment cover

The cover(s) shall be so designed that no contact is made with the battery cells or connectors when a force of 980 N is applied to the cover(s) over any area 300 mm × 300 mm. The cover(s) shall be fitted in such a way as to prevent unintentional displacement.

4.9 Visibility/lighting

4.9.1 Visibility

The visibility requirements for burden and personnel carriers shall be in accordance with ISO 13564-1.

Visibility is subject to regional requirements, additional to the requirements of this part of ISO 3691. See ISO/TS 3691-7 and ISO/TS 3691-8.

4.9.2 Lighting

Ride-on carriers shall be so designed that it is possible, referring to the manufacturer's instructions, to equip them with travel lights, working lights and signal lights.

4.10 Environmental conditions

4.10.1 Operator's cab

4.10.1.1 Fire resistance

All material and components of the cab shall be fire resistant with a maximum burning speed of 250 mm/min when the standard test piece is tested in accordance with ISO 3795.

4.10.1.2 Ventilation

If a totally enclosed cab is fitted, provision shall be made for efficient ventilation.

4.10.1.3 Heater, demister and defroster

If a totally enclosed cab is fitted with a heater/demister the air intake should be connected to a fresh air inlet; recycling of the air is permissible. The heater shall be securely fixed. The heater shall be so designed that the requirements of [4.6.4](#) can be met. Demist/defrost capability shall be provided for the windscreen and rear window.

4.10.1.4 Wipers and washers

Windscreen wiper(s) and washer(s) shall be fitted to allow the operator a clear view of the operating area. Wiper(s) and washer(s) for the rear screen may be omitted if the carrier is driven predominantly in the forward direction. Wiper(s) and washer(s) may be omitted if the carrier only operates within an enclosed area. If glass is used in the window apertures it shall be toughened or laminated.

4.10.1.5 Access and an emergency exit

The cab shall have at least one door plus an emergency exit, which may be a window, allowing escape in another direction, complying with the requirements of ISO 2867.

4.10.1.6 Storage of the instruction handbook

Provision shall be made for storage of the instruction handbook such that it does not obstruct the normal operator position.

4.10.1.7 Additional operator's position

Positions for additional operator(s) shall meet the relevant requirements of [4.10.1.1](#) to [4.10.1.6](#).

4.10.2 Noise emissions

Noise emissions are subject to regional requirements, additional to the requirements of this part of ISO 3691. See ISO/TS 3691-7.

4.10.3 Vibration

Whole body vibration is subject to regional requirements, additional to the requirements of this part of ISO 3691. See ISO/TS 3691-7.

4.10.4 Electromagnetic compatibility (EMC)

EMC is subject to regional requirements, additional to the requirements of this part of ISO 3691. See ISO/TS 3691-7 and ISO/TS 3691-8.

4.11 Transport

4.11.1 Location for lifting and/or slinging points

When a carrier can be lifted without disassembling, locations for lifting and/or slinging points shall be provided and shall be indicated on the carrier and/or in the instruction handbook.

When individual assemblies of the carrier can be removed for normal operation and/or transport, then lifting and/or slinging points shall be provided and shall be indicated on the assemblies and/or in the instruction handbook.

Slinging points for transportation of the carrier or attachments shall be arranged so that there is no possibility of sudden movements.

4.11.2 Tie-down points

Tie-down points for transportation of the assembled carrier shall be provided and indicated on the carrier or in the instruction handbook.

Tie down points for the removal and transportation of individual assemblies of the carrier, if required, shall be indicated on the assembly or in the instruction handbook.

4.11.3 Slinging of removable attachments

Locations for slinging of removable attachments shall be provided as stated in the instruction handbook.

5 Verification of safety requirements and/or protective measures

5.1 General

The manufacturer shall have verification that the safety requirements and/or protective measures given in [Clause 4](#) have been incorporated into the design and manufacture of the truck. Either one or a combination of the following shall be used to achieve verification:

- a) by design, e. g. verification of drawings and documents, or calculation;
- b) by measurement, e. g. tests of travelling and lowering speed or lift and tilt leakage;
- c) by visual examination, e.g. no permanent deformation after tests, verification of the marking of the truck;
- d) by further testing.

5.2 Functional verification

Functional verification shall be carried out on each carrier to verify that it is able to perform the tasks for which it was designed. These tests shall be done according to the manufacturer's instructions. They shall be performed by trained persons either operating and testing the carrier according to the manufacturer's instructions or simulating these tests by any method giving equivalent effect and producing substantially the same result.

Each carrier shall be inspected to make sure that the travelling, braking, steering and combined functions, if any, are appropriately identified and operate correctly. The correct operation of warning devices, safety devices, and lighting, if any, shall also be checked.

6 Information for use

6.1 General

Each carrier shall be supplied to the user with an instruction handbook covering operating and regular servicing printed in the language of the country where the carrier is to be used where it is required by national law. See also ISO 12100:2010, 6.4.5.

There is no need for the workshop and parts handbooks intended for use by specialized personnel employed by the manufacturer or their authorized representative to be supplied with each carrier and these can be printed in the language of the country where the carrier is to be used, as required by the national law. In other cases the instructions shall be in a language agreed upon between the carrier supplier and purchaser.

6.2 Instruction handbook(s)

6.2.1 Concerning the carrier

The instruction handbook(s) shall include, as applicable, at least the following information:

- a) name and address of the manufacturer or, where applicable, his authorized representative;
- b) designation or type;
- c) description of the carrier;
- d) details for the installation of a fire extinguisher, if required by the application of the carrier;
- e) admissible wheel rims and tyres with inflation pressures for pneumatic tyres;
- f) description of the safety devices and warning labels.

6.2.2 Operation of the carrier

6.2.2.1 All carriers

The instruction handbook(s) shall include, as applicable, at least the following information:

- a) intended use of the carrier and examples of hazardous misuse;
- b) training required by the operator;
- c) function of operating controls and displays;
- d) daily checks before putting the carrier into operation;
- e) instructions for adjustment of the operator's seat;
- f) instructions for access and egress;
- g) de-energizing of stored energy components;
- h) instructions when operating on a gradient;
- i) requirements of the ground surface where the carrier is to be used;
- j) use of additional aids or methods when the operator's direct visibility is limited;
- k) instructions for towing the carrier;
- l) instructions for parking the carrier;

- m) warning of residual risks during the use of the carrier and its attachments;
- n) climatic conditions in which the carrier is designed to operate;
- o) information or instructions on action to be taken in the event of malfunctions;
- p) the normal operating conditions (conditions defined by the manufacturer), i.e. those for which the carrier had been designed and the manner in which the carrier will be used;
- q) instructions on the use of the operator restraint device;
- r) information about lighting of the working area;
- s) instructions for disposing of waste materials (e.g. oils and batteries).

Instruction on the operation of the truck is subject to regional requirements, additional to the requirements of this part of ISO 3691. See ISO/TS 3691-7.

6.2.2.2 Details for battery-powered carriers

The instruction handbook(s) shall include, as applicable, at least the following information:

- a) specification of approved batteries and battery chargers;
- b) service mass of battery including ballast, when required;
- c) procedure for safe handling of batteries, including installation, removal and secure mounting on the carrier;
- d) warning of risks of accumulation of hydrogen under covers;
- e) battery charging procedures and instructions.

6.2.2.3 Details for internal combustion engine powered carriers

- a) approved fuels;
- b) procedure for safe handling of fuels;
- c) procedure for refuelling;
- d) warning of the effect of exhaust emission in confined spaces;
- e) warning of the effect of exhaust emission for the operator and passengers;
- f) safety instructions if LPG is used.

6.2.3 Service and maintenance of the carrier

The instruction handbook(s) shall include, as applicable, at least the following information:

- a) training and qualifications for service and maintenance staff;
- b) safe procedure for the identification, detection and correction of faults;
- c) type and frequency of inspections and maintenance operations with particular attention to the replacement and durability of wear parts and to the user's logbook;
- d) drawings and diagrams necessary for carrier servicing and maintenance;
- e) instructions for changing wheels with split wheel rims for inflatable tyres;
- f) de-energizing of stored energy components;

- g) instructions for verification of marking;
- h) servicing operations for which no specific skills are required;
- i) use of approved spare parts;
- j) drawings and diagrams necessary for carrier service and maintenance;
- k) instructions for disposing of waste material (e.g. oils and batteries).

6.2.4 Transportation, commissioning and storage

The instruction handbook(s) shall include, as applicable, at least the following information:

- a) mass and overall dimensions of the carrier and dismantled parts for transport, commissioning and storage;
- b) procedures for transporting, including loading and unloading;
- c) procedure for carrier reassembly and mounting of attachments;
- d) functional tests on completion of commissioning;
- e) procedure for movement of inoperative carriers;
- f) procedure for prolonged shutdown and storage of carriers.

6.2.5 Truck modification

6.2.5.1 Unauthorized truck modification is not permitted. The text of [6.2.5.3](#) shall be included in the instruction handbook and workshop handbook.

6.2.5.2 Except where provided in [6.2.5.3](#), no modifications or alterations to a truck covered by this part of ISO 3691, which may affect, for example, capacity, stability or safety requirements of the truck, shall be made without the prior written approval of the original truck manufacturer, his authorized representative, or a successor thereof. This includes changes affecting, for example, braking, steering, visibility and the addition of removable attachments. When the manufacturer or his successor approves a modification or alteration, he shall also make and approve appropriate changes to the capacity plate, decals, tags and operation and maintenance handbooks.

6.2.5.3 Only in the event that the truck manufacturer is no longer in business and there is no successor interested in the business may the user arrange for a modification or alteration to a truck covered by this part of ISO 3691, provided, however, that the user

- a) arrange for the modification or alteration to be designed, tested and implemented by engineer(s) expert in industrial trucks and their safety,
- b) maintain a permanent record of the design, test(s) and implementation of the modification or alteration,
- c) approve and make appropriate changes to the capacity plate(s), decals, tags and instruction handbook,
- d) affix a permanent and readily visible label to the truck stating the manner in which the truck has been modified or altered together with the date of the modification or alteration, and the name and address of the organization that accomplished the tasks.

6.3 Marking

6.3.1 Information plates

Carriers shall be marked legibly and indelibly (e.g. weather-proof profiled letters) with the following minimum details:

- a) name and address of the manufacturer or, where applicable, his authorized representative;
- b) designation of series or type and compliance with requirements of this part of ISO 3691, applicable to the manufacturer;
- c) serial number and year of manufacture;
- d) capacity of carrier in kilograms and/or the number of passengers;
- e) on battery-powered carriers the authorized minimum and maximum battery mass and the system voltage; the nameplates for batteries in a lift-out/roll-out tray shall show the total combined service weight of batteries and tray;
- f) nominal power, in kilowatts;
- g) if necessary, the maximum supporting force on the tow hook, in newtons;
- h) mass, in kilograms, of the carrier without traction battery; the mass may vary from the value shown by up to $\pm 5\%$ or 1 000 kg, whichever is the lower;
- i) drawbar pull in newtons and also the period of time during which this pull can be exerted.

Marking is subject to regional requirements, additional to the requirements of this part of ISO 3691. See ISO/TS 3691-7.

6.3.2 Marking of controls

Controls shall be legibly and indelibly marked (e.g. weather proof, profiled letters) with graphic symbols indicating the function(s) except where obvious. Each symbol shall be affixed on or in close proximity to the control to which it applies. Control symbols shall comply with ISO 3287 where available.

6.3.3 Other information

6.3.3.1 Marking for slinging of carriers

Locations for slinging shall be clearly indicated on the carrier or be declared in the instruction handbook.

6.3.3.2 Pneumatic tyre inflation pressure

The specified inflation pressures shall be clearly indicated on the carrier.

6.3.3.3 Filling points

Filling points for fuel and hydraulic fluid shall be clearly indicated on the carrier in accordance with ISO 3287.

6.3.3.4 Warning symbols

Symbols giving warnings of remaining hazards shall be affixed to the carrier and to attachments on or in close proximity to the hazard concerned. On stored energy devices (see 4.1.5), a warning label and the method for removing any stored energy shall be affixed to that component and noted in the service handbook. Warnings shall conform to ISO 15870.

6.3.3.5 Languages

If any of the information in [6.3.3.1](#) to [6.3.3.4](#) is in words, it shall be written in the language(s) of the country in which the carrier is to be used in accordance with national law. In other cases, the instructions shall be in a language agreed upon between the carrier supplier and the purchaser.

Annex A (informative)

List of significant hazards

This list contains all the significant hazards, hazardous situations and events, as far as they are dealt with in this part of ISO 3691, identified by risk assessment of carriers and which require action to eliminate or reduce the risk. See [Table A.1](#).

NOTE The structure of the table is based on that of ISO 12100:2010, Table B.1. The order of lines within a group corresponds to the truck functionalities.

Table A.1 — List of significant hazards

No.	Type or group/origin	Potential consequences	Clause/Subclause	Corresponding requirement	
1	Mechanical hazards				
	<ul style="list-style-type: none"> — Acceleration, deceleration (kinetic energy) — Machinery mobility — Moving elements — Rotating elements 	— Being run over	4.1.3	Electrical requirements	
		— Being thrown	4.1.5	Stored energy components	
		— Crushing	4.2	Starting/Moving	
		— Drawing-in or trapping	4.3	Brakes	
		— Impact		4.4	Manual control actuators
				4.5.3	Access to engine and other compartments
				4.6.3.1	Operator's seat
				4.6.3.2	Passenger seats
				4.6.3.3	Restraints and handholds
				4.6.3.4	Protection from road wheels and objects thrown up
				4.6.3.5	Platform
				4.8.1	Warning device
				4.8.4	Battery restraint devices
				5	Verification of safety requirements and/or protective measures
		6	Information for use		
<p>^a Explosive atmospheres are subject to regional requirements, additional to the requirements of this part of ISO 3691. See ISO/TS 3691-7 and ISO/TS 3691-8.</p> <p>^b Noise emissions are subject to regional requirements, additional to the requirements of this part of ISO 3691. See ISO/TS 3691-7.</p>					

Table A.1 (continued)

No.	Type or group/origin	Potential consequences	Clause/Subclause	Corresponding requirement
	<ul style="list-style-type: none"> — Angular parts — Approach of a moving element to a fixed part — Cutting parts — Sharp edges 	<ul style="list-style-type: none"> — Crushing — Cutting or severing — Drawing-in or trapping — Entanglement — Shearing — Stabbing or puncture 	4.1.4	Edges and angles
			4.1.5	Stored energy components
			4.2	Starting/moving
			4.3	Brakes
			4.4	Manual control actuators
			4.4.2.6	Additional operation from outside the carrier
			4.5.3	Access to engine and other compartments
			4.6	Operator and passenger positions
			4.6.3.4	Protection from road wheels and objects thrown up
			4.6.5	Protection against crushing, shearing and trapping
			4.8.2	Devices for towing
			4.8.4	Battery restraint devices
	— Elastic elements	<ul style="list-style-type: none"> — Crushing — Impact — Cutting or severing — Shearing — Stabbing or puncture 	4.1.5	Stored energy components
			4.8.3	Wheels with split wheel rims for inflatable tyres
			5	Verification of requirements
			6	Information for use
	— Falling objects	<ul style="list-style-type: none"> — Crushing — Impact 	4.7	Stability
			4.11	Transport
			5	Verification of requirements
			6	Information for use
	— High pressure	— Injection	4.1.5	Stored energy components
			4.5.4	Liquefied petroleum gas (LPG) carriers
			5	Verification of safety requirements and/or protective measures
			6	Information for use
	— Rough, slippery surface	— Slipping, tripping and falling	4.6.2	Compartment floor

^a Explosive atmospheres are subject to regional requirements, additional to the requirements of this part of ISO 3691. See ISO/TS 3691-7 and ISO/TS 3691-8.

^b Noise emissions are subject to regional requirements, additional to the requirements of this part of ISO 3691. See ISO/TS 3691-7.

Table A.1 (continued)

No.	Type or group/origin	Potential consequences	Clause/Subclause	Corresponding requirement
	— Stability	— Being thrown	4.7	Stability
		— Crushing	4.11	Transport
		— Impact	5	Verification of safety requirements and/or protective measures
			6	Information for use
2	Electrical hazards			
	— Arc — Electromagnetic phenomena — Electrostatic phenomena — Live parts — Not enough distance from live parts under high voltage — Overload — Parts which have become live under fault conditions — Short-circuit — Thermal radiation	— Burns	4.1.3	Electrical requirements
		— Chemical effects	4.8.5	Unauthorized access
		— Electrocutation	4.8.5.1	Traction battery requirements
			4.8.5.3	Compartment cover
		— Falling, being thrown	5	Verification of safety requirements and/or protective measures
		— Fire	6	Information for use
		— Projection of molten particles		
		— Shock		
3		Thermal hazards		
	— Explosion ^a — Flame — Objects or materials with a high or low temperature — Radiation from heat sources	— Burns	4.1.2	Normal climatic conditions
		— Dehydration	4.1.3	Electrical requirements
		— Discomfort	4.3	Brakes
		— Frostbite	4.5.1	Exhaust and cooling systems
		— Injuries from heat-source radiation	4.5.2	Fuel tank
			4.5.4	Liquefied petroleum gas (LPG) carriers
		— Scalding	4.6.4	Protection from burning
			4.8.5	Traction battery requirements
			4.10.1.1	Environmental conditions — Operator's cab/fire resistance
			4.10.1.3	Environmental conditions — Operator's cab/heater, demister and defroster
			5	Verification of safety requirements and/or protective measures
			6	Information for use
4	Noise hazards			
	No origin of this kind of hazard in industrial trucks covered by these specifications ^b			

^a Explosive atmospheres are subject to regional requirements, additional to the requirements of this part of ISO 3691. See ISO/TS 3691-7 and ISO/TS 3691-8.

^b Noise emissions are subject to regional requirements, additional to the requirements of this part of ISO 3691. See ISO/TS 3691-7.

Table A.1 (continued)

No.	Type or group/origin	Potential consequences	Clause/Subclause	Corresponding requirement
5	Vibration hazards			
	No origin of this kind of hazard in industrial trucks covered by these specifications			
6	Radiation hazards			
	No origin of this kind of hazard in industrial trucks covered by these specifications			
7	Material/substance hazards			
	<ul style="list-style-type: none"> — Combustible — Explosive^a — Flammable — Fluid — Fume — Gas 	<ul style="list-style-type: none"> — Breathing difficulties, suffocation — Cancer — Corrosion — Effects on reproductive capability — Explosion^a — Fire — Infection — Mutation — Poisoning — Sensitization 	4.1.3	Electrical requirements
			4.5.1.1	Exhaust system
			4.5.2.1	Tank isolation
			4.5.2.2	Fuel spillage
			4.5.4	Liquefied petroleum gas (LPG) carriers
			4.8.5.2	Battery compartment
			4.10.1.2	Environmental conditions — Operator's cab/ventilation
			5	Verification of safety requirements and/or protective measures
			6	Information for use
8	Ergonomic hazards			
<p>^a Explosive atmospheres are subject to regional requirements, additional to the requirements of this part of ISO 3691. See ISO/TS 3691-7 and ISO/TS 3691-8.</p> <p>^b Noise emissions are subject to regional requirements, additional to the requirements of this part of ISO 3691. See ISO/TS 3691-7.</p>				

Table A.1 (continued)

No.	Type or group/origin	Potential consequences	Clause/Subclause	Corresponding requirement
	<ul style="list-style-type: none"> — Access — Design or location of indicators and visual display units — Design, location or identification of control devices — Effort — Local lighting — Mental overload/underload — Posture — Repetitive activity — Visibility 	<ul style="list-style-type: none"> — Discomfort — Fatigue — Musculo-skeletal disorders — Stress — Any other (e.g. mechanical, electrical) as a consequence of human error 	4.1.2	Normal climatic conditions
			4.1.3	Electrical requirements
			4.5.1	Exhaust and cooling systems
			4.6.1	Operator and passenger positions/dimensions
			4.6.3.1	Operator's seat
			4.6.3.2	Passenger seats
			4.6.3.5	Platform
			4.6.4	Protection from burning
			4.9	Visibility/lighting
			4.10.1	Environmental conditions — Operator's cab
		5	Verification of safety requirements and/or protective measures	
		6	Information for use	
9	Hazards associated with environment in which machine is used			
	<ul style="list-style-type: none"> — Dust and fog — Electromagnetic disturbance — Lightning — Moisture — Temperature — Water — Lack of oxygen 	<ul style="list-style-type: none"> — Burns — Slight disease — Slipping, falling — Suffocation — Any other as a consequence of the effect caused by the sources of the hazards on the machine or parts of the machine 	4.1.2	Normal climatic conditions
			4.9	Visibility/Lighting
			4.10.1.3	Environmental conditions — Operator's cab/heater, demister and defroster
			6	Information for use
10	Combination of hazards			
	E.g. repetitive activity + effort + high environmental temperature	E.g. dehydration, loss of awareness, heat stroke	4.1.2	Normal climatic conditions
			5	Verification of safety requirements and/or protective measures
			6	Information for use
<p>^a Explosive atmospheres are subject to regional requirements, additional to the requirements of this part of ISO 3691. See ISO/TS 3691-7 and ISO/TS 3691-8.</p> <p>^b Noise emissions are subject to regional requirements, additional to the requirements of this part of ISO 3691. See ISO/TS 3691-7.</p>				

Bibliography

- [1] ISO 9001, *Quality management systems — Requirements*
- [2] ISO 24135-1, *Industrial trucks — Specifications and test methods for operator restraint systems — Part 1: Lap-type seat belts*

