**Industrial trucks — Safety
requirements and verification —**

**Part 2:
Self-propelled variable-reach trucks**

*Chariots de manutention — Exigences de sécurité et vérification —
Partie 2: Chariots automoteurs à portée variable*



COPYRIGHT PROTECTED DOCUMENT

© ISO 2016, Published in Switzerland

All rights reserved. Unless otherwise specified, no part of this publication may be reproduced or utilized otherwise in any form or by any means, electronic or mechanical, including photocopying, or posting on the internet or an intranet, without prior written permission. Permission can be requested from either ISO at the address below or ISO's member body in the country of the requester.

ISO copyright office
Ch. de Blandonnet 8 • CP 401
CH-1214 Vernier, Geneva, Switzerland
Tel. +41 22 749 01 11
Fax +41 22 749 09 47
copyright@iso.org
www.iso.org

Contents

Page

Foreword	v
Introduction	vi
1 Scope	1
2 Normative references	1
3 Terms and definitions	3
4 Safety requirements and/or protective measures	5
4.1 General.....	5
4.1.1 Overall requirements.....	5
4.1.2 Normal climatic conditions.....	5
4.1.3 Normal operating conditions.....	5
4.1.4 Sharp edges.....	6
4.1.5 Electrical requirements.....	6
4.1.6 Stored energy components.....	6
4.2 Starting/moving.....	6
4.2.1 Unauthorized starting.....	6
4.2.2 Unintended movement and inadvertent activation.....	6
4.3 Brakes.....	7
4.3.1 General.....	7
4.3.2 Failure of energy supply.....	7
4.4 Manual control actuator.....	7
4.4.1 General.....	7
4.4.2 Travel and braking controls.....	7
4.4.3 Steering controls.....	8
4.4.4 Load-handling controls.....	8
4.4.5 Other controls.....	9
4.4.6 Marking.....	9
4.5 Power systems and accessories.....	9
4.5.1 Exhaust system.....	9
4.5.2 Cooling system.....	9
4.5.3 Fuel tanks.....	10
4.5.4 Access to engine and other compartments.....	10
4.5.5 Liquefied petroleum gas (LPG)-powered trucks.....	10
4.6 Systems for telescoping, lifting and tilting.....	12
4.6.1 Lift chains.....	12
4.6.2 Hydraulic lifting, telescoping and carriage tilting.....	13
4.6.3 Hydraulic systems.....	14
4.6.4 Fork arms.....	14
4.6.5 Fork-arm extensions.....	14
4.6.6 Fork carriers.....	14
4.6.7 Load-handling attachments.....	15
4.7 Operator positions.....	15
4.7.1 Dimensions.....	15
4.7.2 Operator's seat.....	15
4.7.3 Operator restraint.....	16
4.7.4 Operator access and egress.....	16
4.7.5 Protection from road wheels and objects thrown up by the wheels.....	17
4.7.6 Protection from burning.....	17
4.7.7 Protection against crushing, shearing and trapping.....	17
4.8 Stability.....	17
4.8.1 General.....	17
4.8.2 Specific operating conditions.....	18
4.8.3 Longitudinal stability determination.....	18
4.9 Protective devices.....	18

4.9.1	Overhead guard.....	18
4.9.2	Load backrest extension.....	18
4.9.3	Roll-over protective structures.....	19
4.9.4	Warning device.....	19
4.9.5	Starter battery requirements.....	19
4.10	Visibility and lighting.....	19
4.10.1	Visibility.....	19
4.10.2	Lighting.....	19
4.11	Operator's cab.....	19
4.11.1	General.....	19
4.11.2	Doors and windows.....	19
4.11.3	Fire resistance.....	20
4.11.4	Ventilation.....	20
4.11.5	Heating, air conditioning and ventilation system.....	20
4.11.6	Air filters.....	21
4.11.7	Demisting and defrosting.....	21
4.11.8	Pressurization system.....	21
4.11.9	Wipers and washers.....	21
4.11.10	Access and an emergency exit.....	22
4.11.11	Storage of instruction handbook.....	22
4.11.12	Additional operator's position.....	22
4.12	Provisions for transportation of the truck and removable attachments.....	22
4.13	Environmental requirements.....	22
4.13.1	Noise emissions.....	22
4.13.2	Vibration.....	22
4.13.3	Electromagnetic compatibility (EMC).....	23
4.14	Devices for towing.....	23
5	Verification of safety requirements and/or protective measures.....	23
5.1	General.....	23
5.2	Structural verification.....	23
5.2.1	Test loads.....	23
5.2.2	Static test.....	23
5.2.3	Dynamic test.....	24
5.3	Functional verification.....	24
6	Information for use.....	25
6.1	General.....	25
6.2	Instruction handbook.....	25
6.2.1	Truck/attachments.....	25
6.2.2	Operation of truck.....	25
6.2.3	Details for battery powered trucks.....	26
6.2.4	Details for internal-combustion-engine powered trucks.....	26
6.2.5	Service and maintenance.....	27
6.2.6	Transportation, commissioning and storage.....	27
6.2.7	Truck modification.....	27
6.3	Marking.....	28
6.3.1	Information plates.....	28
6.3.2	Load chart.....	29
6.3.3	Information plate for trucks operating in special conditions.....	31
6.3.4	Other information.....	31
6.3.5	Languages.....	32
6.3.6	Operator restraint.....	32
	Annex A (informative) Rated capacity of truck.....	33
	Annex B (informative) List of significant hazards.....	36
	Bibliography.....	41

Foreword

ISO (the International Organization for Standardization) is a worldwide federation of national standards bodies (ISO member bodies). The work of preparing International Standards is normally carried out through ISO technical committees. Each member body interested in a subject for which a technical committee has been established has the right to be represented on that committee. International organizations, governmental and non-governmental, in liaison with ISO, also take part in the work. ISO collaborates closely with the International Electrotechnical Commission (IEC) on all matters of electrotechnical standardization.

The procedures used to develop this document and those intended for its further maintenance are described in the ISO/IEC Directives, Part 1. In particular the different approval criteria needed for the different types of ISO documents should be noted. This document was drafted in accordance with the editorial rules of the ISO/IEC Directives, Part 2 (see www.iso.org/directives).

Attention is drawn to the possibility that some of the elements of this document may be the subject of patent rights. ISO shall not be held responsible for identifying any or all such patent rights. Details of any patent rights identified during the development of the document will be in the Introduction and/or on the ISO list of patent declarations received (see www.iso.org/patents).

Any trade name used in this document is information given for the convenience of users and does not constitute an endorsement.

For an explanation on the meaning of ISO specific terms and expressions related to conformity assessment, as well as information about ISO's adherence to the WTO principles in the Technical Barriers to Trade (TBT) see the following URL: [Foreword - Supplementary information](#)

The committee responsible for this document is ISO/TC 110, *Industrial trucks*, Subcommittee SC 2, *Safety of powered industrial trucks*.

ISO 3691 consists of the following parts, under the general title *Industrial trucks — Safety requirements and verification*:

- *Part 1: Self-propelled industrial trucks, other than driverless, variable-reach and burden-carrier trucks*
- *Part 2: Self-propelled variable-reach trucks*
- *Part 3: Additional requirements for trucks with elevating operator position and trucks specifically designed to travel with elevated loads*
- *Part 4: Driverless industrial trucks and their systems*
- *Part 5: Pedestrian-propelled trucks*
- *Part 6: Burden and personnel carriers*
- *Part 7: Regional requirements for countries within the European Community* [Technical Specification]
- *Part 8: Regional requirements for countries outside the European Community* [Technical Specification]

Introduction

General

This document is a type-C standard as stated in ISO 12100.

The machines concerned and the extent to which hazards, hazardous situations or hazardous events are covered are indicated in the Scope of this document.

When requirements of this type-C standard are different from those which are stated in type-A or B standards, the requirements of this type-C standard take precedence over the requirements of the other standards for machines that have been designed and built according to the requirements of this type-C standard.

The ISO 3691- series of standards covers safety requirements and their verification for industrial trucks as defined in ISO 5053-1.

Structure

An important step forward in the work on the ISO 3691- series of standards was the agreement to issue a new structure of International Standards for industrial trucks having on one side basic standards for all kinds of trucks (see Foreword) and on the other side independent standards to cover the respective specific functions of industrial trucks, e.g. visibility, noise, vibration, electrical requirements, etc.

Assessment of hazards

The product needs to be designed in such a way that it is fit for its purpose or function and can be adjusted and maintained without putting persons at risk when used under the conditions foreseen by the manufacturer.

In order to properly design a product and to cover all specific safety requirements, the manufacturer will have to identify the hazards that apply to his product and carry out a risk assessment. The manufacturer will then need to design and construct the product taking this assessment into account.

The aim of this procedure is to eliminate the risk of accidents throughout the foreseeable lifetime of the machinery, including the phases of assembling and dismantling where risks of accidents could also arise from foreseeable abnormal situations.

In selecting the most appropriate methods, the manufacturer will need to apply the following principles, in the order given here:

- a) eliminate or reduce risks as far as possible by design (inherently safe machinery design and construction);
- b) take the necessary protective measures in relation to risks that cannot be eliminated by design;
- c) inform users of any shortcoming of the protective measures adopted;
- d) indicate whether any particular training is required;
- e) specify any need to provide personal protection equipment;
- f) refer to the appropriate user's document for proper operating instructions.

Industrial trucks need to be designed to prevent foreseeable misuse wherever possible, if such would engender risk. In other cases, the instructions will need to draw the user's attention to ways shown by experience in which the machinery ought not to be used.

This part of ISO 3691 does not repeat all the technical rules which are state-of-the art and which are applicable to the material used to construct the industrial truck. Reference will also need to be made to ISO 12100.

Legislative situation/Vienna Agreement

From the very beginning, the task of the working group was to revise ISO 3691:1980 and establish worldwide basic standards to comply with the major legislative regulations in, for example, the EU, Japan, Australia and North America.

Every effort was made to develop a globally relevant International Standard. That goal was achieved with most of the issues. For several potential problem areas compromises were needed and will be needed in the future. Where divergent regional requirements remain, these are addressed by ISO/TS 3691-7 and ISO/TS 3691-8.

In order to ensure that the revised International Standard will be actively used in the ISO member countries, worldwide, procedures will be necessary to replace the existing national standards and technical regulations by the revised International Standard. In the European Community, ISO and the European Committee for Standardization (CEN) agreed on technical co-operation under the Vienna Agreement, with the aim of replacing European Standards (EN) by International Standards. Other countries are asked to make similar agreements to ensure that their national standards and technical regulations are replaced by this International Standard.

Only by these actions will there be the guarantee that products in accordance with International Standards can be shipped worldwide freely without any technical barriers.

Industrial trucks — Safety requirements and verification —

Part 2: Self-propelled variable-reach trucks

1 Scope

This part of ISO 3691 gives safety requirements and the means for their verification for self-propelled industrial variable-reach trucks and variable-reach container handlers/reach stackers as defined in ISO 5053-1 (hereafter referred to as *trucks*), equipped with forks or integral load-handling devices for normal industrial duties (e.g. fork arms or means, such as spreaders, for handling containers).

It is not applicable to

- rough-terrain variable-reach trucks,
- rough-terrain variable-reach trucks for handling containers,
- machines designed primarily for earth-moving (e.g. loaders and dozers), even when their buckets and blades are replaced with forks,
- machines from which the load can swing freely in all directions.

For the purposes of this part of ISO 3691, fork arms and integrated attachments are considered to be a part of the truck, whereas attachments/equipment mounted on the load carrier or on the fork arms which are removable by the user are not. Nevertheless, requirements for such attachments are also given by the document.

Any regional requirements additional to the provisions of this part of ISO 3691 are addressed in ISO/TS 3691-7 and ISO/TS 3691-8.

This part of ISO 3691 deals with all significant hazards, hazardous situations or hazardous events, as listed in [Annex B](#), with the exception of the following, relevant to the applicable machines when used as intended and under conditions of misuse which are reasonably foreseeable by the manufacturer.

It does not establish requirements for hazards that can occur

- during construction,
- when using trucks on public roads,
- when operating in potentially explosive atmospheres, or
- when lifting persons.

2 Normative references

The following documents, in whole or in part, are normatively referenced in this document and are indispensable for its application. For dated references, only the edition cited applies. For undated references, the latest edition of the referenced document (including any amendments) applies.

ISO 2328, *Fork-lift trucks — Hook-on type fork arms and fork arm carriages — Mounting dimensions*

ISO 2330, *Fork-lift trucks — Fork arms — Technical characteristics and testing*

ISO 3691-2:2016(E)

ISO 2867, *Earth-moving machinery — Access systems*

ISO 3287, *Powered industrial trucks — Symbols for operator controls and other displays*

ISO/TS 3691-7, *Industrial trucks — Safety requirements and verification — Part 7: Regional requirements for countries within the European Community*

ISO/TS 3691-8, *Industrial trucks — Safety requirements and verification — Part 8: Regional requirements for countries outside the European Community*

ISO 3411:2007, *Earth-moving machinery — Physical dimensions of operators and minimum operator space envelope*

ISO 3795, *Road vehicles, and tractors and machinery for agriculture and forestry — Determination of burning behaviour of interior materials*

ISO 4413, *Hydraulic fluid power — General rules and safety requirements for systems and their components*

ISO 5053-1, *Industrial trucks — Terminology and classification — Part 1: Types of industrial trucks*

ISO 5353, *Earth-moving machinery, and tractors and machinery for agriculture and forestry — Seat index point*

ISO 6055:2004, *Industrial trucks — Overhead guards — Specification and testing*

ISO 6292, *Powered industrial trucks and tractors — Brake performance and component strength*

ISO 10263-2, *Earth-moving machinery — Operator enclosure environment — Part 2: Air filter element test method*

ISO 10263-3, *Earth-moving machinery — Operator enclosure environment — Part 3: Pressurization test method*

ISO 10263-4, *Earth-moving machinery — Operator enclosure environment — Part 4: Heating, ventilating and air conditioning (HVAC) test method and performance*

ISO 12100:2010, *Safety of machinery — General principles for design — Risk assessment and risk reduction*

ISO 13284, *Fork-lift trucks — Fork-arm extensions and telescopic fork arms — Technical characteristics and strength requirements*

ISO 13564-1, *Powered industrial trucks — Test methods for verification of visibility — Part 1: Sit-on and stand-on operator trucks and variable-reach trucks up to and including 10 t capacity*

ISO 15870, *Powered industrial trucks — Safety signs and hazard pictorials — General principles*

ISO 15871, *Industrial trucks — Specifications for indicator lights for container handling and grappler arm operations*

ISO 21281, *Construction and layout of pedals of self-propelled sit-down rider-controlled industrial trucks — Rules for the construction and layout of pedals*

ISO 22915-1, *Industrial trucks — Verification of stability — Part 1: General*

ISO 22915-10, *Industrial trucks — Verification of stability — Part 10: Additional stability test for trucks operating in the special condition of stacking with load laterally displaced by powered devices*

ISO 22915-11, *Industrial trucks — Verification of stability — Part 11: Industrial variable-reach trucks*

ISO 22915-12, *Industrial trucks — Verification of stability — Part 12: Industrial variable-reach trucks handling freight containers of 6 m (20 ft) length and longer*

ISO 22915-20, *Industrial trucks — Verification of stability — Part 20: Additional stability test for trucks operating in the special condition of offset load, offset by utilization*

ISO 24135-1, *Industrial trucks — Specifications and test methods for operator restraint systems — Part 1: Lap-type seat belts*

3 Terms and definitions

For the purposes of this document, the terms and definitions given in ISO 5053-1 and ISO 12100, and the following apply.

3.1

self-propelled industrial variable-reach truck

seated-rider-operated, counterbalanced lift truck with one or more articulated arms, telescopic, non-slewing, used for stacking loads and for operation on smooth, level, prepared and consolidated surfaces

3.2

actual capacity at maximum lift height with forks

maximum load, Q_2 , specified by the manufacturer that the truck is capable of lifting to its maximum height in normal operating conditions

Note 1 to entry: It is equal to the maximum load, with centre of gravity G (see [Figure A.1](#)), carried on the *fork arms* ([3.7](#)) at the standard load centre distance, D , as specified in [Annex A](#), and with the *boom* ([3.9](#)) adjusted to its maximum height. It is expressed in kilograms.

3.3

actual capacity at container position with spreader

maximum load, Q , with row (d) and height (h), specified by the manufacturer that the truck is capable of lifting to its maximum height in normal operating conditions

3.4

axle locking

mechanism designed to stop oscillation of the rear axle so as to improve truck stability

3.5

stabilizer

extendable or pivoting mechanical supports used to improve stability of a stationary truck

3.6

lateral levelling

act of changing the angular relationship between the boom pivot and the ground in order to adjust the boom pivot to horizontal when the truck is standing on a side slope

Note 1 to entry: Used to ensure that the *boom* ([3.9](#)) operates in a vertical plane.

3.7

fork arms

device consisting of two or more solid forks, hook-mounted or shaft-mounted, that is fitted on the carriage and usually spread manually

3.8

fork arm extension

device fitted over the *fork arms* ([3.7](#)) to increase their length

3.9

boom

pivoting support member providing radial and telescoping (if equipped) movement of the load-engaging means

**3.10
spreader**

device fitted to the *boom* (3.9), designed to connect the lifting points of freight containers, swap bodies and semi-trailers

Note 1 to entry: It can include powered devices used to connect the lifting points of the load and an articulated mechanism to facilitate engagement.

**3.11
bucket**

device intended for carrying bulk products such as sand, gravel or coal

**3.12
overhead guard**

device fitted to the truck for the purpose of protecting the operator against falling objects

**3.13
load backrest**

portion of the fork carriage serving to restrain the load when the load is tilted rearward or upward

**3.14
normal operating position**

position in which the operator is able to control all functions for driving and load handling as defined by the manufacturer

Note 1 to entry: Additional positions may be defined by the manufacturer if it is not possible to control all the functions of the truck from a single position. A rotating seat or stand-up end-control truck with more than one operating direction is considered as being or having a single operating position.

**3.15
fork carrier**

device fitted at the end of the *boom* (3.9) to connect and lock interchangeable attachments without the use of a tool

**3.16
auxiliary mast**

mast at the end of the *boom* (3.9) intended for reaching greater lifting heights

Note 1 to entry: Referred to simply as *mast* in this part of ISO 3691.

**3.17
non-slewing**

having a slewing movement not greater than 5° on either side of the longitudinal axis of the truck

Note 1 to entry: See [Figure 1](#).

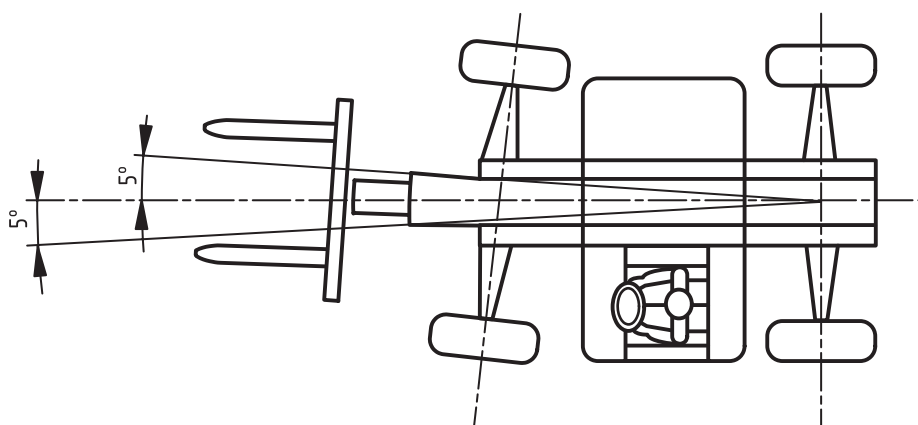

Figure 1 — Slewing movement $\leq 5^\circ$ (non-slewing)

3.18**rated capacity with fork arms**

load, Q_1 , in kilograms, permitted by the manufacturer, that the truck type is capable of transporting and lifting in normal operating conditions with the boom fully retracted

Note 1 to entry: For centre of gravity G.

Note 2 to entry: The rated capacity is used to compare the capacity of different manufacturers' trucks and to provide the break points used in technical standards and statistics. The operating limits for the truck are defined by the *actual capacity* (3.2, 3.3).

3.19**rated capacity with spreader**

load, Q_1 , in kilograms, permitted by the manufacturer that the truck type is capable of transporting and lifting in normal operating conditions with the spreader in the position of the first container row at measurement d_1 and lift height 6,5 m

Note 1 to entry: For the second container, see [Figure A.2](#).

4 Safety requirements and/or protective measures**4.1 General****4.1.1 Overall requirements**

The truck shall comply with the safety requirements and/or protective measures of this clause.

In addition, the truck shall be designed according to the principles of ISO 12100:2010 for relevant but not significant hazards which are not dealt with by this document.

4.1.2 Normal climatic conditions

For truck operation, the following climatic conditions apply:

- average ambient temperature for continuous duty: + 25 °C;
- maximum ambient temperature, short term (up to 1 h): + 40 °C;
- lowest ambient temperature for trucks intended for use in normal indoor conditions: + 5 °C;
- lowest ambient temperature for trucks intended for use in normal outdoor conditions: – 20 °C;
- altitude: up to 2 000 m.

4.1.3 Normal operating conditions

Normal operating conditions are the following:

- driving (travelling and lifting) on substantially firm, smooth, level and consolidated surfaces — the surface conditions on which the truck is designed to operate shall be specified in the instruction handbook (see [6.2](#));
- driving with the horizontal load centre of gravity approximately on the longitudinal centre plane of the truck;
- travelling with the boom retracted and, if fork arms are fitted, with these tilted backwards and both with and without a load, the load in the designated travel position.

If the above is not sufficient to allow the conditions for stability of a particular truck type to be specified, then the operating conditions shall be according to the International Standards referenced for stability in [4.8](#).

4.1.4 Sharp edges

There shall be no sharp edges or angles posing a hazard in the area of the operator in the normal operating position or in the area of access and egress during normal operation and daily checks.

NOTE For guidance, see ISO 12508.

4.1.5 Electrical requirements

Electrical requirements are subject to regional requirements. See ISO/TS 3691-7 and ISO/TS 3691-8.

4.1.6 Stored energy components

Components which store energy and that would cause a risk during removal or disassembly, e.g. hydraulic accumulator or spring-applied brakes, shall be provided with a means to release the energy before removal or disassembly.

4.2 Starting/moving

4.2.1 Unauthorized starting

Trucks shall be provided with a device (e.g. key, code, magnetic card) which prevents starting without its use.

4.2.2 Unintended movement and inadvertent activation

Truck movement from the holding position, other than by actuation of the controls by the operator, due to drift or creep (e.g. by leakage), shall be avoided.

4.2.2.1 Parking brake

A parking brake shall be provided complying with [4.3.1](#).

Failure of the control system of an automatically applied parking brake shall be indicated to the operator.

4.2.2.2 Internal-combustion-engine powered trucks

Internal-combustion-engine powered trucks shall be fitted with a device which prevents the engine being started while the transmission is engaged.

4.2.2.3 Travel controls

Travel controls shall be so arranged that on level ground the truck will not move from rest until the transmission has been engaged.

4.2.2.4 Powered travel movement

Powered travel movement of the truck shall be possible only if the operator is in the normal operating position.

Powered travel shall not occur automatically when the operator returns to the normal operating position without an additional operation, e.g. by requiring a resetting of the direction control or reactivation of the speed control.

4.3 Brakes

4.3.1 General

All industrial trucks shall be designed with service and parking brakes. Brakes shall comply with ISO 6292.

The parking brake shall be equipped with a system preventing unintentional release. The parking brake force shall be applied by mechanical means.

Braking requirements are subject to regional requirements, additional to the requirements of this part of ISO 3691. See ISO/TS 3691-8.

For sit-down rider trucks, the parking brake system shall be manually operable from the normal operating position or automatically applied by leaving the normal operating position.

Trucks with only non-automatically applied parking brake(s) shall have a warning to the operator to apply brakes before leaving the truck.

4.3.2 Failure of energy supply

Failure of the energy supply to the service brake shall not result in a total loss of braking and shall enable a controlled stop.

4.4 Manual control actuator

4.4.1 General

The controls shall be confined within the plan view outline of the truck's overhead guard or falling object protective structure (FOPS).

NOTE See ISO 6682 for guidance on zones of comfort and reach for operator controls.

4.4.1.1 Consistency with the truck motions

Movement of these controls shall be consistent with the motions of the truck being operated wherever practicable.

4.4.1.2 Multiple operators

If additional operating positions are fitted, e.g. for more than one operator, the operation of these controls shall only be possible from one operating position at a time, excepting the emergency disconnect switch, which shall be operable from all positions.

4.4.1.3 Multiple operating positions

If more than one operating position is fitted for a single operator, the use of the controls for one of these operating positions shall preclude the use of the controls of another operating position. The exception to this is the emergency disconnect switch, which shall be operable from all positions.

4.4.2 Travel and braking controls

4.4.2.1 General

The motion of the speed operating control shall be so designed that an increase in the movement of the control increases the travel speed. When the control is released, it shall return to the neutral position of the control actuator.

4.4.2.2 Pedal-operated travel and braking controls

Trucks with pedal-operated travel and braking controls shall comply with ISO 21281.

4.4.2.3 Differential locking pedal

If the truck is equipped with a pedal -operated differential lock, depressing the pedal shall lock the differential.

If the truck is equipped with a differential lock which is engaged by other means (e.g. switch or hand lever), the engaged and disengaged positions shall be clearly marked.

4.4.2.4 Hand-operated direction control lever

The movement of a direction control lever shall correspond to the required direction of travel.

4.4.2.5 Hand-operated accelerator control

The control lever shall be a hold-to-run control: on release of the control, its movement shall return to minimum speed position. Movement of the control lever to front or clockwise shall increase speed.

4.4.2.6 Hand-operated transmission gear change lever

The positions for gear engagement shall be clearly identified.

4.4.3 Steering controls

4.4.3.1 Steering direction

The following applies.

- a) For trucks with a steering-wheel control, clockwise rotation of a steering wheel shall steer the truck to the right when the truck is travelling in the forward direction.
- b) On trucks with a crab-steer mode (all wheels on the truck turn in the same direction), clockwise rotation of the steering wheel shall move the truck to the right when the truck is travelling in the forward direction and to the left when travelling in the reverse direction.
- c) On trucks where the steering is controlled by means of a single lever controller, moving the lever to the right shall cause the truck to be steered to the right when the truck is travelling in the forward direction. If a reversible control unit or dual controls are fitted, moving the lever to the right shall also steer the truck to the operator's right when the truck is travelling in reverse with the operator facing in that direction.

4.4.3.2 Failure of power supply

In the event of an interruption of the power supplied to the steering system (including a dead motor or engine) it shall be possible to maintain the path being steered until the truck is brought to a controlled stop.

4.4.4 Load-handling controls

4.4.4.1 Controls

Controls shall return to neutral when released and stop load movements.

The controls for the load-handling functions shall be considered as a primary control, located within ergonomic reach of the operator and separated from the driving controls.

Trucks equipped with attachments which hold the load by power (e.g. paper clamp) shall feature control(s) with a secondary action to prevent unintentional release of the load.

4.4.4.2 Multi-function controls

Where a control is designed and constructed to perform more than one function, each separate function shall be clearly marked. Each control function shall return to the neutral position when released and stop the corresponding load movement.

4.4.5 Other controls

4.4.5.1 Stabilizer control

For trucks equipped with stabilizers, a forward or downward motion of the control shall lower the stabilizer, and a rearward or upward motion shall raise the stabilizer.

Where independent or selectable controls for stabilizers are provided, the left control shall operate the left stabilizer and the right control shall operate the right stabilizer. If selectable controls are provided, a middle position may operate both stabilizers.

If other control methods are used, they shall follow the same logic.

4.4.5.2 Sway/levelling control

For trucks equipped with operator controlled lateral levelling, operating the control to the left shall cause the truck to sway to the left, and operating the control to the right shall cause the truck to sway to the right.

If other control methods are used, they shall follow the same logic.

4.4.5.3 Axle locking

When axle locking is used, operated by a control lever, locking shall be engaged by forward or downward motion of the control and disengaged by backward or upward motion of the control. If other control methods are used, they shall follow the same logic.

4.4.6 Marking

Graphic symbols used for marking controls shall comply with [6.3.1.3](#).

4.5 Power systems and accessories

4.5.1 Exhaust system

The exhaust system shall be designed in accordance with [4.7.6](#) and such that engine exhaust is directed away from the operator position. Materials used in the vicinity of exhaust systems shall be non-flammable and shall be chosen and protected such that they are not adversely affected by heat from the exhaust system.

4.5.2 Cooling system

The air flow through the cooling system shall be arranged so as to avoid discomfort to the operator.

4.5.3 Fuel tanks

4.5.3.1 Tank isolation

If a fuel tank is within or adjacent to the engine compartment and excessively high temperatures may occur, the tank and/or filling arrangement shall be isolated from the electrical and exhaust systems by suitable protection, e.g. a separate enclosure or baffles. The tank location and facilities for filling shall be such that spillage or leakage will not drain into the engine or operators compartment nor onto unprotected electrical or exhaust system parts.

4.5.3.2 Fuel spillage

Fuel spillage shall not be possible under normal operating conditions.

4.5.4 Access to engine and other compartments

4.5.4.1 Engine covers

An enclosed engine compartment shall satisfy fan guarding requirements when the manufacturer's recommended routine maintenance is performed with the engine off. If a fan can start (e.g. temperature switch) when the engine is off, the fan shall be guarded. A safety warning sign shall be provided, and included in the instruction handbook (see [6.2](#)). Warnings shall comply with [6.3.4.5](#).

4.5.4.2 Unintentional closure

Where unintentional closure could cause injury, access covers (i.e. traction battery or engine covers) shall be provided with means for preventing unintentional closure. Those means shall be permanently affixed to the truck or stored in a safe place on the truck.

4.5.5 Liquefied petroleum gas (LPG)-powered trucks

4.5.5.1 Containers

The following applies to the containers of trucks powered by LPG.

- a) LPG containers shall be either permanently fixed to the truck or removable.
- b) When LPG containers are removable, their fastenings shall permit easy handling and checking of the installation after the exchange of containers.
- c) Removable LPG containers that incorporate a pressure relief valve shall be so positioned on the truck that the pressure relief valve opening is always in communication with the vapour space at the top of the container. This may be accomplished, for example, by an indexing pin which positions the container when the container is properly installed.
- d) LPG containers shall be securely mounted to the truck to prevent movement. Fastening shall withstand static loading of four times the filled container weight in any direction without permanent visible deformation.
- e) LPG containers shall be fitted on the truck such that exposure to abrasion, shock and the corrosive action of the products handled by the truck is reduced.
- f) LPG containers and their connections shall be installed such that there are no projections outside the plan view outline of the truck.
- g) If LPG containers are installed in a compartment, this compartment shall have permanent openings at the bottom. The total surface area of these ventilation openings shall be at least 200 cm², allowing adequate ventilation to outside the truck.

- h) If an additional LPG container is carried on the truck, it shall be secured in the same manner as the main container.
- i) LPG containers, whether fixed or removable, shall be equipped with a device to prevent unintentional emission of gas or liquid, e.g. in the case of a pipe system failure. This does not apply to pressure-relief valves.
- j) Pipe fittings and accessories on LPG containers shall be protected against mechanical damage when used as specified by the manufacturer.
- k) The fuel take-off on the LPG container shall be equipped with an easily and quickly accessible manually operated valve. The position and method of operation of this valve shall be clearly marked on the valve handle or on the outside of the truck near the valve.
- l) The fuel take-off shall be in a liquid form unless the LPG container and engine are specially equipped for a direct vapour withdrawal.
- m) Permanently mounted LPG containers to be filled by the user shall be fitted with the following:
 - 1) a pressure relief valve connected to the vapour space of the container that, when fitted inside the compartments of trucks, shall have the discharge side of the relief valve piped to the atmosphere away from the operator and that shall comply with [4.5.5.3 d\)](#), below;
 - 2) an 80 % fill stop valve;
 - 3) maximum liquid level devices suitable for the LPG in use, indicating the maximum product level and which shall not vent to the atmosphere.
- n) LPG containers shall be positioned such that they are not exposed to the damaging effects of heat — particularly heat from the engine or the exhaust system. If it is necessary to fit a heat shield, this shall not inhibit ventilation.

4.5.5.2 Piping

The following applies to the piping used on trucks powered by LPG.

- a) Connecting piping and all associated parts shall be easily accessible, protected against excessive heat radiation, damage and wear, and shall be flexible enough to withstand vibration and deformation in service, as follows:
 - 1) piping shall be so arranged that damage or leaks are easily detectable and that checks and maintenance can be carried out;
 - 2) piping shall be installed such that it cannot be damaged by any excessive heat radiation from hot parts of the truck;
 - 3) fully rigid pipes shall not be used for connecting the container to equipment on the engine;
 - 4) piping shall be so arranged that there are no projections outside the plan view outline of the truck.
- b) Pressure hoses operating above 1 bar ¹⁾ shall be supported at least every 500 mm. Rigid pipes shall be supported at least every 600 mm.
- c) Hoses, pipes and all connections operating at pressures above 1 bar shall be suitable for a working pressure of 25 bar and shall withstand without bursting a test pressure of 75 bar. Hoses, pipes and all connections operating below 1 bar shall withstand without bursting a test pressure of five times the maximum working pressure.

1) 1 bar = 0,1 MPa = 0,1 N/mm² = 10⁵ N/m².

- d) Pressure shall not exceed the working pressure rating of components in any section of pipe work containing LPG in liquid form between two shut-off valves that are closed; a pressure relief valve, for example, or other suitable means may be used if necessary.
- e) Aluminium piping shall not be used.
- f) Hoses shall be as short as practical.
- g) Pressure unions and joints operating above 1 bar shall be made of metal except for any constrained sealing washers.

4.5.5.3 Equipment

The following applies to the equipment used on trucks powered by LPG.

- a) The supply of gas shall be automatically cut off when the engine stops, irrespective of whether or not the ignition system has been switched off.
- b) For multi-fuel applications, the system shall be designed to avoid the possibility of LPG entering any other fuel container and to shut off each fuel source before the alternative one is opened.
- c) If the truck is equipped with two or more containers to supply fuel, they shall be connected via a multi-way valve or other suitable means, so that LPG can only be drawn from one container at a time. The use of two or more containers at the same time shall not be possible.
- d) Pressure-relief valves or liquid-level indicators shall be installed such that they cannot discharge in the direction of the operator or onto truck components that could be a source of ignition.
- e) If corrosion of a part would interfere with its proper functioning, that part shall be provided with a corrosion-resistant protective coating.
- f) All fuel system components shall be firmly secured to the truck.
- g) Pressure-reducing valves shall be readily accessible for inspection and maintenance.
- h) The engine compartment shall be designed in accordance with [4.5.5.1 g\)](#), in order to avoid any LPG accumulation.

4.5.5.4 Regional requirements

LPG-powered trucks are subject to regional requirements, additional to the requirements of this part of ISO 3691. See ISO/TS 3691-8.

4.6 Systems for telescoping, lifting and tilting

4.6.1 Lift chains

The truck or mast manufacturer shall have on record a certificate from the chain manufacturer giving the breaking load of the chains used.

When the lifting mechanism (lifting, telescoping) includes a chain or chains, the truck manufacturer shall only use leaf or roller chains. These shall provide a minimum factor, K_1 , when the truck and boom are stationary in the least favourable position:

$$K_1 = (L_c \times n) / (R + w)$$

where

K_1 is the safety factor of the lifting mechanism;

- L_c is the minimum breaking load for new chain;
 n is the number of chains;
 R is the maximum load capacity of the truck;
 w is the friction in boom.

The K_1 factor shall be in accordance with [Table 1](#). The K_1 factor is subject to regional requirements, additional to the requirements of this part of ISO 3691. See ISO/TS 3691-8.

Table 1 — K_1 factor

Trucks up to and including 10 000 kg rated capacity	$K_1 \geq 5$
Trucks over 10 000 kg rated capacity	$K_1 \geq 5 - 0,2 (Q' - 10)$ where Q' is the truck rated capacity in tonnes and K_1 shall never be less than 4.

For variable-reach trucks, K_1 shall be related to the maximum static load that would exist in a single or equally loaded chain when the truck and boom are stationary in the least favourable positions.

Loads in the chain(s) due to friction in the lifting mechanism shall be taken into account.

Pulley diameters shall follow the chain manufacturer's instructions

4.6.2 Hydraulic lifting, telescoping and carriage tilting

4.6.2.1 Load holding

In the event of a failure in the hydraulic circuit of the load lifting, telescoping or carriage tilting systems, means shall be provided to maintain the load and truck in its position.

4.6.2.1.1 Boom lift and telescoping systems

With the boom fully extended and elevated to the least favourable position, with the load for that position as determined by the load chart, and with the oil in the hydraulic system at operating temperature, the descent of the load caused by leakage in the hydraulic system in the first 10 min shall not exceed:

- 100 mm for trucks up to and including 10 000 kg rated capacity;
- 200 mm for trucks over 10 000 kg rated capacity.

4.6.2.1.2 Fork arm tilt systems

With the fork arms and carriage in the least favourable position, and with the truck's maximum rated load, the decent of the fork arms shall not exceed $0,5^\circ$ during 10 min with the oil in the hydraulic system at operating temperature.

4.6.2.1.3 Maximum load lowering speed

The maximum permissible lowering speed shall be such that, in the event of a sudden stop of the lowering means with the actual load within any load zone at the maximum reach for that zone, the rear wheels of the truck may leave the ground only momentarily and shall return to the ground unassisted.

4.6.2.1.4 Limitation of stroke

Any mechanism on the truck with movement requiring limits to prevent over-travel shall be provided with means for positive stops.

NOTE Hydraulic cylinders fulfil this requirement if designed to limit stroke and/or travel.

4.6.3 Hydraulic systems

4.6.3.1 Hydraulic circuits

In the event of a failure in the hydraulic circuit of the stabilizing or lateral levelling systems, means shall be provided to maintain the load and truck in its position (e.g. rupture valve, check valve etc.).

Hoses, piping and connections subjected to internal pressure shall be capable of withstanding, without bursting or permanent deformation, a pressure equal to at least three times the operating pressure. Pipes and hoses shall be so located and, if necessary, restrained, so that deterioration, sharp edges, and other damage-causing sources are minimized. In the event of physical damage, hoses and pipes should be positioned so that adverse effects of hose burst or pin holes are minimized.

Trucks shall comply with the requirements of ISO 4413.

4.6.3.2 Pressure controls

All hydraulic systems shall include a device which prevents the pressure in the system from exceeding a pre-set level. The device shall be so designed and fitted that unintentional loosening or adjustment is avoided and so that a tool or key is required to alter the pressure setting.

4.6.3.3 Failure of energy supply to hydraulic circuits

In the case of a fault or interruption of the supply of energy, the design of the hydraulic system shall be such that it does not allow any uncontrolled motion of equipment or attachment.

4.6.3.4 Fluid purification

The hydraulic system(s) shall be protected against the risk of contamination of the hydraulic fluid, e.g. by means of magnet(s) or filter(s).

4.6.4 Fork arms

Solid-section fork arms shall be manufactured and tested in accordance with ISO 2330, except with respect to safety factors.

The safety factors are subject to regional requirements, additional to the requirements of this part of ISO 3691. See ISO/TS 3691-8.

The total capacity of all fork arms fitted to a truck shall not be less than the actual capacity of the truck.

Means shall be provided to prevent unintentional lateral displacement of the fork arms on the fork carrier.

4.6.5 Fork-arm extensions

Fork-arm extensions shall be designed to prevent accidental disengagement from the fork arms, and shall be in accordance with ISO 13284.

4.6.6 Fork carriers

Hook-on type fork carriers shall be in accordance with ISO 2328.

4.6.7 Load-handling attachments

4.6.7.1 Unintentional displacement or detachment

Means shall be provided to prevent the unintentional lateral displacement or unintentional detachment of attachments from the truck. Movement of the attachment and its parts shall be mechanically limited at the extreme positions.

4.6.7.2 Malfunction in power supply system

Attachments which hold the load by power shall be designed such that the maximum load they are intended to handle is automatically retained for at least 10 min when the truck's manual controls are in the neutral position or in the event of a malfunction in the power supply system for the attachment.

4.6.7.3 Hydraulic system for attachment

If an attachment has its own separate hydraulic system, this shall comply with [4.6.3](#).

4.6.7.4 Combined hydraulic systems

If an attachment has a hydraulic system that is connected to the truck hydraulic system, the two systems shall be compatible and the combined systems shall comply with [4.6.3](#).

4.6.7.5 Attachment for lifting containers

An attachment for lifting containers shall be equipped with indicator lights in accordance with ISO 15871. The attachment shall have a device(s) to prevent unintentional dropping of a container. Means shall be provided to prevent lifting of the container unless all interface mechanisms are fully engaged and locked. If multiple containers are lifted at the same time, the same requirements are valid for all containers. Travel speed shall be restricted to a maximum of 10 km/h if the container is not locked to the attachment in a manner that will prevent unintentional drop (e.g. lifting with grapple arms).

4.6.7.6 Attachment operating instructions

If a removable attachment requires specific operating and maintenance instructions that are not contained in the truck's instruction handbook (see [6.2](#)), then provisions shall be made on the attachment for storage of the operating and maintenance instructions. The storage provisions shall not obstruct the operator's normal operation of the attachment when on the truck.

If attachment operating instructions can be provided in the form of an operation label on the attachment, then a storage location for a manual is not needed.

4.7 Operator positions

4.7.1 Dimensions

The operator's seat shall be so located that the operator has sufficient room while operating the truck so as to remain within the plan view outline of the truck. The dimensions shall be of suitable and ergonomic shape to accommodate at least a 5th percentile to a 95th percentile of the population and as shown in ISO 3411:2007, Figures 1 to 3, within the plan view outline of the operator's compartment.

4.7.2 Operator's seat

The seat shall be designed and located to provide easy access to the controls, shall provide a position for the truck operator in accordance with ergonomic principles and shall meet the following requirements.

- a) If the seat has a facility allowing forward and backward adjustment this shall be at least 70mm in total and possible without the use of tools.

- b) If a weight-adjustable seat is fitted to reduce vibration transmitted to the operator, the adjustment shall accommodate operator weights of 55 kg to 110 kg. Manual adjustment of the weight mechanism shall be possible without the use of tools.
- c) Rotating seats shall be provided with a mechanism, e.g. a spring to latch type, to lock the seat in position.
- d) The seat mounting shall be able to withstand the forces which can occur during operation, e.g. braking forces, as well as the forces imposed by the operator restraint specified in [4.7.3](#).
- e) The requirements of a) to d), above, also apply to additional operator's seats.

The specification and marking of the operator's seat is subject to regional requirements, additional to the requirements of this part of ISO 3691. See ISO/TS 3691-7.

4.7.3 Operator restraint

Trucks shall have a restraint device, system or enclosure intended to reduce the risk of entrapment of the operator's head and/or torso between the truck and the ground in the event of a tip-over. Such means shall not unduly restrict the operation of the truck, e.g. the operator's access, egress and/or visibility. Warnings and instructions on the purpose, use and action to be taken in the event of a tip-over, so as to reduce the risk associated with the operator's head impacting a solid surface, shall be provided on the truck and described in the instruction handbook (see [6.2](#)).

If a restraint system with a belt is used, this system shall be in accordance with ISO 24135-1.

If additional operating or passenger positions are fitted, they shall comply with all the requirements of [4.7](#).

Regional requirements for restraint devices are given in ISO/TS 3691-8:2012.

4.7.4 Operator access and egress

4.7.4.1 General

Trucks shall be designed to permit safe and easy access and egress and to minimize the risk of slipping, falling and tripping. Steps, running boards and hand holds (grab handles, fixed parts of the truck structure, etc.) shall be provided above a step height of 350 mm to give three-point contact at all heights (i.e. one hand and two feet or two hands and one foot). Step width, instep clearance and toe clearance shall comply with ISO 2867.

4.7.4.2 Steps

Steps shall have slip-resistant surfaces or covering (e.g. expanded metal, abrasive coating). The first step shall be not more than 400 mm from the ground and succeeding steps shall be 250 mm to 350 mm, preferably at equal intervals.

4.7.4.3 Compartment floors

The compartment floor frequented by the operator, steps and walkways shall be free of obstacles and shall have a slip-resistant surface, e.g. ribbed mats, abrasive coating, expanded metal.

4.7.4.4 Walkways

Walkways more than 1 200 mm from the ground shall have guard rails of 1 000 mm to 1 100 mm high. The guard rails shall be capable of withstanding, without permanent deformation, a force of 900 N applied in a horizontal direction from the inside to the outside.

4.7.5 Protection from road wheels and objects thrown up by the wheels

The operator in the normal operating position shall be protected against contact with the truck wheels and against objects thrown up by the wheels (mud, gravel, debris etc.). The protective device for the steered wheels need only cover the wheels when in a straight line position.

4.7.6 Protection from burning

All parts of the truck within reach of the operator in the normal operating position or when the operator is entering or leaving the operating position shall be insulated or shielded so that the surface temperature, generated by heat sources in the truck, of bare metal parts does not exceed 65 °C, and that of painted or plastic parts does not exceed 83 °C. The temperature of the air at the heater outlet, where fitted, shall not exceed 60 °C.

4.7.7 Protection against crushing, shearing and trapping

4.7.7.1 General

Parts that move relative to one another and that are within reach of the operator in the normal operating position shall be adequately guarded. If hazards still exist, they shall be identified according to [6.2](#) and on the truck in accordance with [6.3.4.5](#).

Fixed guards and their mounting systems and fixed and/or removable guard systems are subject to regional requirements, additional to the requirements of this part of ISO 3691. See ISO/TS 3691-7.

4.7.7.2 Minimum distances

Parts separated by the following minimum distances satisfy the adequate guarding requirements of [4.7.7.1](#):

- a) places where only the operator's fingers can be trapped: min. 25 mm;
- b) places where only the operator's hands or feet can be trapped: min. 50 mm;
- c) places where the operator's arms or legs can be trapped: min. 100 mm.

Moving parts that need to be in contact with, or move in close proximity to, one another shall be guarded. Any openings in such guarding shall be small enough to prevent an 8 mm diameter probe from passing through them. If such hazards still exist, they shall be identified on the truck in accordance with [6.3.4.5](#).

4.7.7.3 Attachments

Crushing and shearing hazards to the operator in the normal operating position associated with attachments, except at the load supporting points, shall also meet the relevant requirements of [4.7.7.2](#). If such hazards still exist, they shall be identified according to [6.3](#) and on the attachment in accordance with [6.3.4.5](#).

4.8 Stability

4.8.1 General

In order to reduce the hazards of longitudinal and lateral tip-over in the normal operating conditions foreseen by the manufacturer, the variable-reach trucks specified below shall comply with the requirements given in the applicable part of ISO 22915 without permanent deformation of the structure:

- self-propelled variable-reach industrial trucks, ISO 22915-11;
- self-propelled variable-reach trucks handling containers, ISO 22915-12.

4.8.2 Specific operating conditions

Trucks which provide or allow for offset loads shall be subject to the following additional stability tests, as appropriate:

- trucks operating in the special condition of stacking with load laterally displaced by powered devices, in accordance with ISO 22915-10;
- Trucks operating in the special condition of offset load, offset by utilization in accordance with ISO 22915-20.

4.8.3 Longitudinal stability determination

Means shall be provided on the truck to enable the operator to determine whether the machine and its load is within the maximum limits of longitudinal stability, in accordance with longitudinal stability tests given in the appropriate International Standard specified in [4.8.1](#).

The procedure for determining the mass of an undefined load shall be described in the operator's handbook (see [6.2](#)).

Longitudinal stability is subject to regional requirements, additional to the requirements of this part of ISO 3691. See ISO/TS 3691-7.

4.9 Protective devices

4.9.1 Overhead guard

An overhead guard complying with ISO 6055 shall be fitted on the truck.

When handling a load above 1 800 mm lift height, this guard shall be constructed such that it can be provided with an additional fitting making it possible in special cases to increase the protection of the operator against small falling objects.

Trucks with an operating position not protected by the boom, (e.g. where the boom is adjacent to the side of the cabin and the load can be over the top of the operator's position and / or there is a risk of falling objects) shall meet the requirements of ISO 6055:2004, Clause 4.

If the truck is intended only for handling freight containers with a spreader that does not allow the container over the operator station, a FOPS is not required.

NOTE If the boom is located above the operator's compartment, this is considered as being protected by the boom.

4.9.2 Load backrest extension

4.9.2.1 Provision for load backrest extension

Trucks fitted with fork arms with a lift height of more than 1 800 mm shall be designed so that they can be fitted with a load backrest extension.

4.9.2.2 Size of openings

Load backrest extensions, if provided, shall have height, width, and size openings sufficient to minimize the possibility of the load falling toward the mast when the mast is in a position of maximum rearward tilt.

The size of openings in the load backrest extension, if provided, shall not exceed 150 mm in one of the two dimensions.

4.9.3 Roll-over protective structures

Trucks with an operating position not protected by the boom, (e.g. where the boom is adjacent to the side of the cabin and the load can be over the top of the operator's position and / or there is a risk of roll over) shall meet the requirements of ISO 6055:2004, Clause 4.

If the truck is intended only for handling freight containers with a spreader a ROPs is not required.

4.9.4 Warning device

Trucks shall be equipped with an operator-controlled audible warning device.

4.9.5 Starter battery requirements

The starter battery on engine-powered trucks shall be restrained from movement.

It shall be possible to disconnect batteries quickly, e.g. by a quick coupling or an accessible isolator switch.

Symbol 2063 of ISO 7000 may be used for identification.

4.10 Visibility and lighting

4.10.1 Visibility

Requirements for all-round visibility from unladen trucks up to and including 10 000 kg rated capacity shall be in accordance with ISO 13564-1.

For visibility with load, see [6.2.2](#), considering that, if direct visibility is limited by the load, additional visibility means can be used.

NOTE Visibility requirements for trucks above 10 000kg capacity and container handling trucks are under development.

Visibility is subject to regional requirement to this part of ISO 3691. See ISO/TS 3691-7.

4.10.2 Lighting

Trucks shall be installed with working and signal lights.

Trucks shall be so designed that it is possible, referring to the manufacturer's instructions, to equip them with additional lighting.

NOTE See ISO 12509 for guidance.

4.11 Operator's cab

4.11.1 General

If a cab is fitted in lieu of an overhead guard it shall comply with [4.9.1](#).

The enclosed cab shall be equipped with a fixed inner lighting system. It shall be able to function even if the engine is switched off, to make it possible to illuminate the operator's station and to read the operator's manual in darkness.

4.11.2 Doors and windows

If no cab is fitted or the cab is not glazed, a guard or screen shall be fitted to prevent risk of entrapment of the operator between the boom and structure of the truck.

If glass is used, it shall be toughened or laminated.

Doors, windows and flaps shall be securely held in their functional positions; measures shall be taken for preventing inadvertent opening. Doors shall be retained in their intended operating position(s) by a positive engagement device. The locking device of the open door for the primary opening shall be releasable from the operator's station.

It shall not be possible to open the boom side window where there is a risk of the operator being trapped or crushed by the descending boom adjacent to the cabin.

Where the boom is adjacent to the side of the cabin, means shall be provided to ensure that, in the event of a missing or broken boom-side window, the driver is not at risk of being trapped between the descending boom and the controls. These means shall exclude the driver from the area under the boom or prevent continuing actuation of the controls by the driver's body. Such protection may be provided by other safety devices in addition to their originally intended purposes (e.g. operator presence device, control-enabling device). If such protection relies solely upon the glass of the boom-side window, then the glass shall be of the safety laminated type. The laminated glass shall be made of a minimum of two layers of glass with an interlayer of plastic material. (see for example ECE R43.)

4.11.3 Fire resistance

All material and components of the cab shall be fire-resistant, with a maximum burning speed of 250 mm/min when the standard test piece is tested in accordance with ISO 3795.

4.11.4 Ventilation

If a totally enclosed cab is fitted, provision shall be made for efficient ventilation.

4.11.5 Heating, air conditioning and ventilation system

If a totally enclosed cab is fitted with a heater/demister, the air intake should be connected to a fresh air inlet; recycling of the air is permissible.

If air conditioning is fitted it shall comply with ISO 10263-4.

If a heating system is fitted it shall either

- a) comply with ISO 10263-4, or
- b) have the capability of increasing the temperature of the air inside the enclosed cab and maintain a temperature of 18 °C at minimum ambient temperature the truck is intended for. The minimum capacity of the heating system shall have a ΔT of 25 °C within 30 min.

The test shall be run starting with the engine at working temperature as specified by the manufacturer. Measurement of the system capacity shall be made at three points. The three points shall be located in a vertical plane through the SIP and parallel to the longitudinal axis of the truck as follows (see [Figure 2](#)):

- 1) at 660mm above the SIP and 20 mm in front of it;
- 2) at the SIP as defined in ISO 5353;
- 3) 100 mm above floor plate and 600 mm in front of SIP.

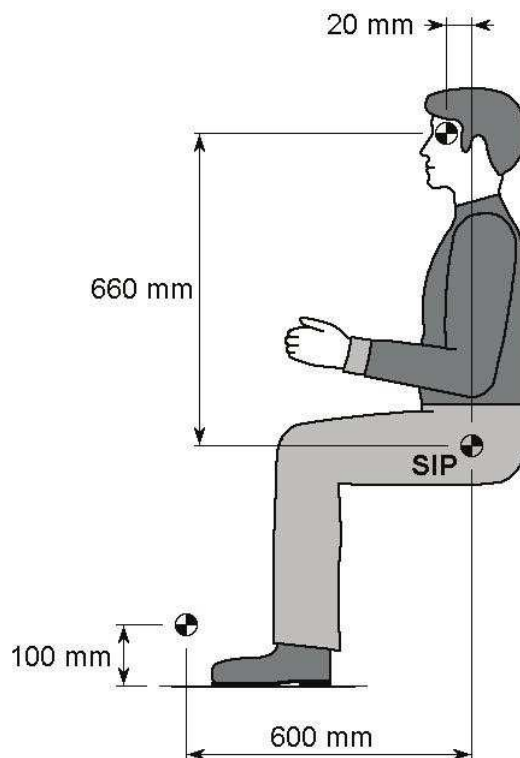

Figure 2 — Location of measuring points

NOTE Alternatively, the heating capacity can be determined by calculation.

4.11.6 Air filters

The filter shall be tested according to ISO 10263-2.

NOTE Filter element selection depends on the intended operating environmental conditions.

4.11.7 Demisting and defrosting

Trucks shall be provided with facilities to demist and defrost the front, the boom-side and rear windows, for example by means of a heating system or a particular defrosting device.

NOTE A testing method of windscreen defrosting system is described in ISO 10263-5.

4.11.8 Pressurization system

Where an enclosed cab is provided with a pressurization system, it shall be tested according to ISO 10263-3 and shall provide an interior relative pressure of at least 50 Pa or 20 Pa minimum, if a pressure indicator is provided.

4.11.9 Wipers and washers

Wiper(s) shall clear a sufficient area to allow the operator to view the attachment or load through the entire lift zone.

The front and rear window(s) shall be fitted with motorised windscreen wiper(s) and washer(s).

Wiper(s) and washer(s) shall be provided for the roof window if it is necessary for the operator to view obstacles, the attachment or the load through the roof window.

The tank of the window washer(s) shall be easily accessible.

4.11.10 Access and an emergency exit

The cab shall have an access and an emergency exit complying with ISO 2867. The emergency exit, which may be a window, shall allow escape in a different direction than that of the normal exit.

4.11.11 Storage of instruction handbook

Provision shall be made for the storage of the instruction handbook (see [6.2](#)) that does not obstruct the normal operating position.

4.11.12 Additional operator's position

If an additional operator's position is equipped within a cab, it shall meet the requirements of [4.7](#)

4.12 Provisions for transportation of the truck and removable attachments

4.12.1 If the manufacturer specifies in the instruction handbook (see [6.2](#)) that a truck may be lifted without disassembling, locations for slinging points shall be provided. These shall be indicated on the truck and identified in the handbook.

4.12.2 If the manufacturer specifies in the instruction handbook (see [6.2](#)) that the truck may be lifted after partial disassembly, lifting points shall be provided to enable lifting of truck elements. These shall be indicated on the truck and identified in the handbook.

4.12.3 If the manufacturer specifies in the instruction handbook (see [6.2](#)) that the truck may be transported partially disassembled, tie down points shall be provided to enable transportation of the truck components. These shall be indicated on the disassembled components and identified in the handbook.

4.12.4 Tie down points (hooks, rings, ears, etc.) shall be provided on the truck to enable the truck to be secured for transportation purposes. These shall be indicated on the truck and identified in the handbook.

4.12.5 If a removable attachment is allowed to be lifted by other than its quick fixing device, the points for lifting or slinging shall be identified.

4.12.6 Securing points shall be provided on removable attachments to enable securing for transportation purposes. These shall be identified on the attachment.

NOTE National regulations apply for transportation.

4.13 Environmental requirements

4.13.1 Noise emissions

Noise emissions are subject to regional requirements. See ISO/TS 3691-7.

4.13.2 Vibration

Whole-body vibrations transmitted to the operator are subject to regional requirements. See ISO/TS 3691-7.

4.13.3 Electromagnetic compatibility (EMC)

EMC is subject to regional requirements. See ISO/TS 3691-7.

NOTE Requirements for EMC are under development.

4.14 Devices for towing

Trucks used for towing trailers shall be fitted with towing or coupling devices designed, constructed and arranged to reduce hazards of connection and disconnection and to prevent accidental disconnection during use.

If a pin is part of the towing device, it shall be securely attached to the device. The securing device for the pin (if needed) shall not be detachable.

NOTE Design requirements for towing devices are given in ISO 6489.

5 Verification of safety requirements and/or protective measures

5.1 General

The manufacturer shall verify that the safety requirements and/or protective measures given in [Clause 4](#) have been incorporated into the design and manufacture of the truck. Either one or a combination of the following shall be used to achieve verification:

- a) by design, e.g. verification of drawings and documents, or calculation;
- b) by measurement, e.g. tests of travelling and lowering speed or lift and tilt leakage;
- c) by visual examination, e.g. no permanent deformation after tests, verification of the marking of the truck;
- d) by further testing.

5.2 Structural verification

5.2.1 Test loads

The test loads are

Q_1 , the rated capacity of the truck,

Q_2 , the actual capacity at maximum lift height with forks or spreader, and

Q_3 , the actual capacity at maximum reach.

See [Figures A.1](#) and [A.2](#).

Two different Q_2 and Q_3 values may be specified: one with the truck on tyres; the other with the truck on stabilizing devices.

5.2.2 Static test

5.2.2.1 Purpose

The purpose of this test is to demonstrate the overall structural integrity of the loaded truck in static conditions.

It shall be applied to each representative type of truck.

5.2.2.2 Test procedure

CAUTION — For this test, it is recommended that the truck be secured to the ground to avoid the risk of overturning.

Trucks shall be type-tested on firm, level ground at 125 % of Q_1 , Q_2 and Q_3 at the corresponding positions.

5.2.2.3 Acceptance criteria

The truck shall be considered as complying with this test if the test load is safely supported for 10 min without permanent deformation or component failure.

5.2.3 Dynamic test

5.2.3.1 Purpose

The purpose of this test is to demonstrate the overall structural integrity of the loaded truck in dynamic conditions. It shall be applied to each representative type of truck.

5.2.3.2 Test procedure

Trucks shall be tested at 100 % of each of the three capacities, Q_1 , Q_2 and Q_3 , in a complete operating cycle, at the maximum engine speed specified by the manufacturer, and from a stationary, fully retracted and lowered boom position to each of the positions specified below, and back again.

See [Figures A.1](#) and [A.2](#).

At the maximum engine speed specified by the manufacturer

- a) bring Q_1 to the fully retracted and maximum lifted position,
- b) bring Q_2 to the fully retracted maximum lifted position and then to maximum height, and
- c) bring Q_3 to maximum reach.

CAUTION — In order to perform this test safely, it is recommended that the truck be secured to the ground.

5.2.3.3 Acceptance criteria

The truck shall be considered as complying with this test if the test is completed without permanent deformation or component failure.

5.3 Functional verification

Functional verification shall be carried out on each truck to verify that it is able to perform the tasks for which it was designed. These tests shall be done according to the manufacturer's instructions. They shall be performed by trained persons either operating and testing the truck according to the manufacturer's instructions or simulating these tests by any method giving an equivalent effect and producing substantially the same result.

Each truck shall be inspected to ensure that the travelling, braking, steering, load handling controls and combined functions, if any, are appropriately identified and operate correctly. The correct operation of warning devices, safety devices and lighting, if any, shall also be checked.

6 Information for use

6.1 General

Each truck and removable attachment shall be supplied to the user with an instruction handbook(s), covering operating and regular servicing and addressing all identified hazards, printed in the language(s) of the country in which the truck is to be used where required by national law. See also ISO 12100:2010, 6.4.

There is no need for maintenance instructions intended for use by specialized personnel employed by the manufacturer or his authorized representative to be supplied with each truck.

6.2 Instruction handbook

6.2.1 Truck/attachments

The instruction handbook(s) shall include, as applicable, at least the following information:

- a) name and address of the manufacturer or authorized representative;
- b) designation of series or type, e.g. container-stacking variable-reach truck, industrial variable-reach truck;
- c) description of the truck;
- d) attachments supplied with the truck and their assembly precautions;
- e) details of use of a removable load backrest extension;
- f) details for the installation of a fire extinguisher, if required by the application of the truck;
- g) admissible wheel rims and tyres with inflation pressures for pneumatic tyres;
- h) description of safety devices and warning labels.

6.2.2 Operation of truck

The instruction handbook(s) shall include, as applicable, at least the following information:

- a) intended uses of the truck and attachments and examples of hazardous misuse;
- b) training requirements for the operator;
- c) function of operating controls and displays;
- d) pre-shift checks before the truck is put into operation;
- e) instructions for adjustment of the operator's seat;
- f) instructions for operation with/without cab, with/without doors;
- g) instructions for access and egress;
- h) instructions for safe handling by the operator, e.g. when changing attachments or moving fork arms;
- i) requirements of the ground/floor where the truck is to be used;
- j) instructions for starting, driving and stopping the truck;
- k) instructions for handling loads, warning about the hazards due to the action of wind forces;
- l) instructions when operating on a gradient;

ISO 3691-2:2016(E)

- m) instructions for towing the truck;
- n) instructions for parking the truck;
- o) warning of risks during the use of the truck and its attachments, including crushing and shearing hazards;
- p) climatic conditions in which the truck is designed to operate;
- q) information about the direction of turning of the truck in relation to rotation of the steering wheel for end-controlled trucks;
- r) information about operating the truck with loads causing insufficient visibility;
- s) information on the use of any visual aid that may be provided;
- t) information and conditions for the use of the drawbar;
- u) information or instructions on action to be taken in the event of a malfunction;
- v) the normal operating conditions as defined by the manufacturer, i.e. those for which the truck has been designed and the manner in which the truck will be used;
- w) instructions on the use of the operator-restraint device, system or enclosure, and guidance on the operator's behaviour in the event of a tip-over;
- x) information about lighting of the working area;
- y) the procedure for movement of inoperative trucks;
- z) instructions against operating the truck with guarding removed;
- aa) lift height for travelling;
- bb) information regarding attachment or spreader movements and the effects on the trucks stability, i.e. side shift;

6.2.3 Details for battery powered trucks

The instruction handbook(s) shall include, as applicable, at least the following information:

- a) specification of approved batteries and on-board battery chargers;
- b) procedure for safe handling of batteries, including installation, removal and secure mounting on the truck;
- c) warning of risks of accumulation of hydrogen gas under covers;
- d) battery charging procedures and instructions.

6.2.4 Details for internal-combustion-engine powered trucks

The instruction handbook(s) shall include at least the following information:

- a) approved fuels;
- b) approved additive(s);
- c) procedure for safe handling of fuels and additive(s);
- d) procedure for refilling additive(s) and refuelling;
- e) warning of the effect of exhaust emissions in confined spaces;

- f) warning of the effect of exhaust emissions for the operator.

6.2.5 Service and maintenance

The instruction handbook(s) shall include, as applicable, at least the following information:

- a) training and qualifications needed for service and maintenance staff;
- b) safe procedure for the identification, detection and correction of faults;
- c) instructions for changing tyres or wheels;
- d) instructions for verification that markings, e.g. decals, are in place and legible;
- e) instructions for de-energizing of stored energy components;
- f) warning of particular hazards and the correct procedure to be followed during maintenance, e.g. those associated with wheel hubs;
- g) access to maintenance while working at height;
- h) servicing operations for which no specific skills are required;
- i) use of approved spare parts;
- j) drawings and diagrams necessary for truck service and maintenance;
- k) instructions for disposing of waste material (e.g. oils and battery);
- l) type and frequency of inspections and maintenance operations, with particular attention to the replacement and durability of wear and serviceable parts, emissions, and to the user's logbook (e.g. filter, brakes, chains, hydraulic hoses);
- m) instructions for removing and reattaching guarding;

6.2.6 Transportation, commissioning and storage

The instruction handbook(s) shall include, as applicable, at least the following information:

- a) mass and overall dimensions of the truck and dismantled parts for transport, commissioning and storage;
- b) procedures for transporting, including loading and unloading;
- c) procedure for truck reassembly and mounting of attachments;
- d) functional tests on completion of commissioning;
- e) procedure for retrieval of defective trucks;
- f) procedure for prolonged shut down and storage of trucks.

6.2.7 Truck modification

6.2.7.1 Unauthorized truck modification is not permitted. The text of [6.2.7.3](#) shall be included in the instruction handbook and the maintenance instructions.

6.2.7.2 Except where provided in [6.2.7.3](#), no modifications or alterations to a powered industrial truck, which could affect, for example, capacity, stability or safety requirements of the truck, shall be made without the prior written approval of the original truck manufacturer, its authorized representative, or a successor thereof. This includes changes affecting, for example braking, steering, visibility and the addition of removable attachments. When the manufacturer or his successor approves a modification

or alteration, the manufacturer or successor shall also make and approve appropriate changes to the capacity plate, decals, tags and operation and maintenance handbooks.

6.2.7.3 Only in the event that the truck manufacturer is no longer in business and there is no successor in the interest to the business, may the user arrange for a modification or alteration to a powered industrial truck, provided, however, that the user shall

- a) arrange for the modification or alteration to be designed, tested and implemented by an engineer(s) expert in industrial trucks and their safety,
- b) maintain a permanent record of the design, test(s) and implementation of the modification or alteration,
- c) approve and make appropriate changes to the capacity plate(s), decals, tags and instruction handbook, and
- d) affix a permanent and readily visible label to the truck stating the manner in which the truck has been modified or altered, together with the date of the modification or alteration and the name and address of the organization that accomplished those tasks.

6.3 Marking

6.3.1 Information plates

6.3.1.1 Trucks

Trucks shall be marked legibly and indelibly (e.g. weather-proofed, profiled letters) with at least the following details, on one or more labels:

- a) name and address of the manufacturer or his authorized representative;
- b) designation of series or type and compliance with requirements of this part of ISO 3691;
- c) serial number and year of manufacture;
- d) actual capacity at maximum lift height with load centre distance;
- e) actual capacities at other lift heights and load centre distances if applicable;
- f) actual capacity with each removable attachment fitted at the manufacturer's authorized lift height(s) and load centre(s), these actual capacities being easily readable by the operator in the normal operating position;
- g) on battery-powered trucks, the authorized maximum and minimum battery mass and the system voltage;
- h) identification of the originally equipped front-end attachment
- i) unladen mass of the truck fully equipped and serviced, without the operator
- j) if fitted, the maximum supporting force on the towing point connection, in newtons;
- k) if fitted, the drawbar pull on the towing point connection, in newtons;

Marking requirements are subject to regional requirements, additional to the requirements of this part of ISO 3691. See ISO/TS 3691-7 and ISO/TS 3691-8.

6.3.1.2 Removable attachments

Removable attachments shall be marked legibly and indelibly (e.g. weather-proofed, profiled letters) with at least the following details:

- a) name and address of the attachment manufacturer or his authorized representative;
- b) model or type;
- c) serial number and year of manufacture;
- d) mass of attachment; for attachments having interchangeable components (e.g. carriages that accept different types of fork), the mass of the attachment without the interchangeable components shall be given;
- e) distance of the centre of gravity of the attachment from its mounting face on the truck, where this mounting shall be, for forked attachments, that portion of the attachment in contact with the vertical member of the fork,
- f) capacity of the attachment where, for those attachments where the capacity can vary depending upon the capacity of interchangeable components (e.g. carriages that accept different types of fork), the maximum capacity of the attachment with permissible interchangeable components shall be specified;
- g) in the case of hydraulically or pneumatically operated attachments, the maximum operating pressure recommended by the attachment manufacturer;
- h) load centre, if applicable;
- i) lost load centre distance;
- j) the instruction

“The capacity of the truck and attachment combination shall be complied with.”;

- k) the instruction (or equivalent)

“The capacity of the truck and attachment combination may be less than the capacity shown on attachment. Refer to load chart for the truck, attachment, and/or fork combination used.”

6.3.1.3 Marking of controls

Controls shall be legibly and indelibly marked (e.g. weather proof, profiled letters) with graphic symbols indicating the function(s) except where these are obvious, e.g. accelerator pedal. Each symbol shall be affixed on or in close proximity to the control to which it applies. Control symbols shall comply with ISO 3287, for existing symbols.

6.3.2 Load chart

6.3.2.1 Trucks with forks

Every truck shall have a legible and durable load chart affixed in a prominent position, easily readable by the operator in the normal operating position, providing information on the actual capacities of the truck (see [Figure 3](#) for an example). The load chart shall provide information on

- a) the type of attachment to which it applies,
- b) applicable load centre distances, and
- c) actual capacities at lift heights and reaches.

The load chart may be combined with the nameplate.

For trucks equipped with stabilizers, load charts shall be provided showing capacities when the stabilizers are deployed, and when they are not deployed.

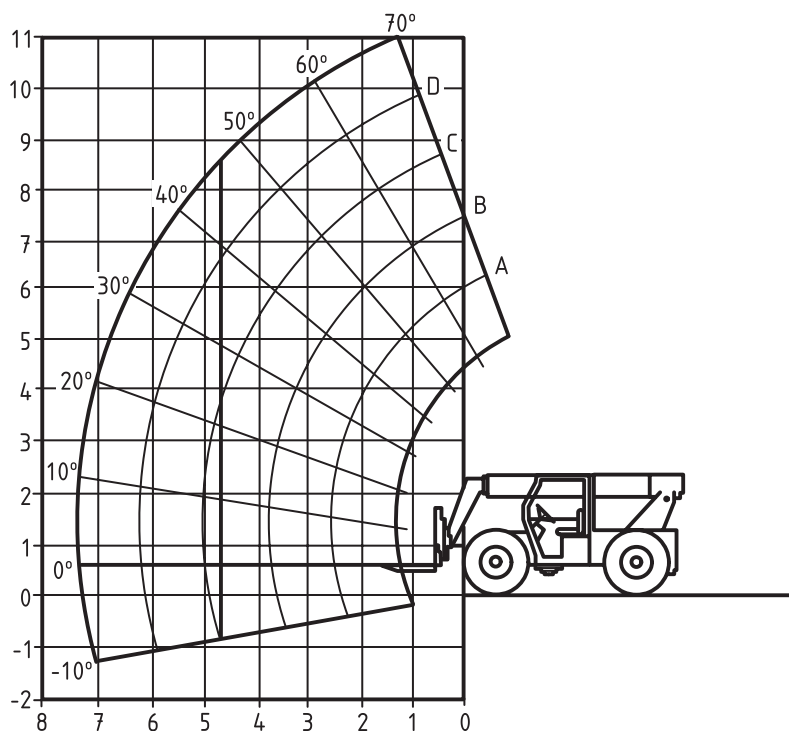

Figure 3 — Load chart for trucks with forks

6.3.2.2 Trucks with load-carrying attachments

Where the manufacturer has authorized their use, trucks with attachments — whether fitted to the fork arms or to a fork carrier — shall be fitted with an appropriate load chart. The load chart shall be legible and durable, and affixed in a prominent position, easily readable by the operator in the normal operating position. The load chart shall provide information on

- a) the type of attachment to which it applies,
- b) applicable load centre distances,
- c) actual capacities at lift heights and reaches, and
- d) applicable limitations on the attachments use.

The load chart may be combined with the name-plate.

For trucks equipped with stabilizers, load charts shall be provided showing capacities when the stabilizers are deployed, and when they are not deployed.

Load charts with and without stabilizers may be combined.

6.3.2.3 Trucks with non-load carrying attachments

For non-load carrying attachments, i.e. breakers and brooms, which normally operate near the ground, and which comply with the stability criteria in 4.8.1, a load chart need not be installed on the truck. If necessary, specific operating instructions for the limits on the attachment's position, i.e. lift height or reach, shall be provided in the attachment manual or by other means.

6.3.2.4 Trucks for container handling

Every truck shall have a legible and durable load chart affixed in a prominent position, easily readable by the operator in the normal operating position, providing information on the actual capacities of the truck (see [Figure 4](#) for an example). The load chart shall provide information on

- a) the type of spreader to which it applies,
- b) applicable load centre distances for each container row, and
- c) actual capacity at container position with spreader.

The load chart may be combined with the nameplate.

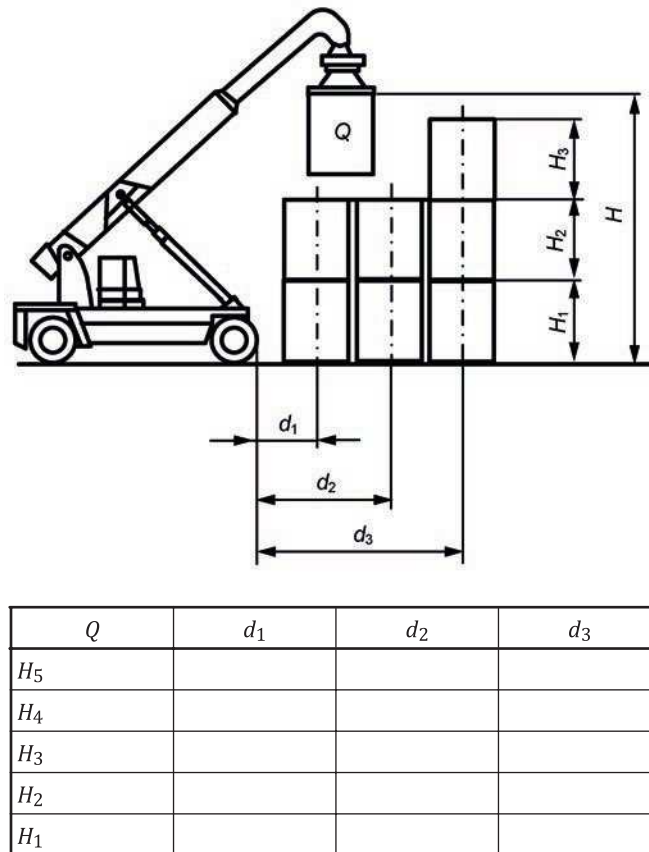

Figure 4 — Load chart for container handling

6.3.3 Information plate for trucks operating in special conditions

If a truck is designed to operate in special conditions, it shall be marked legibly and indelibly (e.g. weather-proofed, profiled letters) with the designation of the special conditions of use, including the capacity if different from the actual capacities.

6.3.4 Other information

6.3.4.1 Marking for lifting and tie-down of trucks

Locations for tie-down, and — if provided — lifting (e.g. slinging), shall be clearly indicated on the truck. Symbols for lifting and tie down shall comply with ISO 3287.

6.3.4.2 Pneumatic tyre inflation pressure

The specified inflation pressures shall be clearly indicated on the truck, and the symbol shall comply with ISO 3287.

6.3.4.3 Filling points

Filling points for fuel, additives, oils and hydraulic fluids shall be clearly indicated on the truck, and symbols shall comply with ISO 3287.

6.3.4.4 Stored energy devices

A warning label and the method for removing the stored energy from such devices shall be affixed to the component and noted in the service manual.(see [4.1.6.](#))

6.3.4.5 Warnings

Symbols giving warnings of remaining hazards shall be affixed to the truck and attachments on or in close proximity to the hazard concerned. Warnings shall conform to ISO 15870.

6.3.5 Languages

If any of the information in [6.3.1](#) to [6.3.3](#) is in words, it shall be written in the language(s) of the country in which the truck is to be used in accordance with national law. In other cases, the instructions shall be in a language agreed between the truck supplier and purchaser.

6.3.6 Operator restraint

Information or symbols giving instructions for the use of the operator restraint system or enclosure shall be easily readable by the operator in the normal operating position. Symbols shall conform to ISO 3287.

Annex A (informative)

Rated capacity of truck

A.1 Rated capacity with fork arms

The rated capacity with fork arms, defined in 3.18, is equal to maximum load Q_1 , with centre of gravity, G , at the height when G is at its most forward position at measurement d , which the truck is designed to carry on the fork arms at the standard load centre distance, D (see Figure A.1): where d is the distance between two vertical parallel planes — one tangent to the front outside diameter of the front tyres and the other to the extremity of the curve passing through G with the boom fully retracted — and where G is the load centre of gravity positioned in the longitudinal plane that passes through the central point between the front wheels.

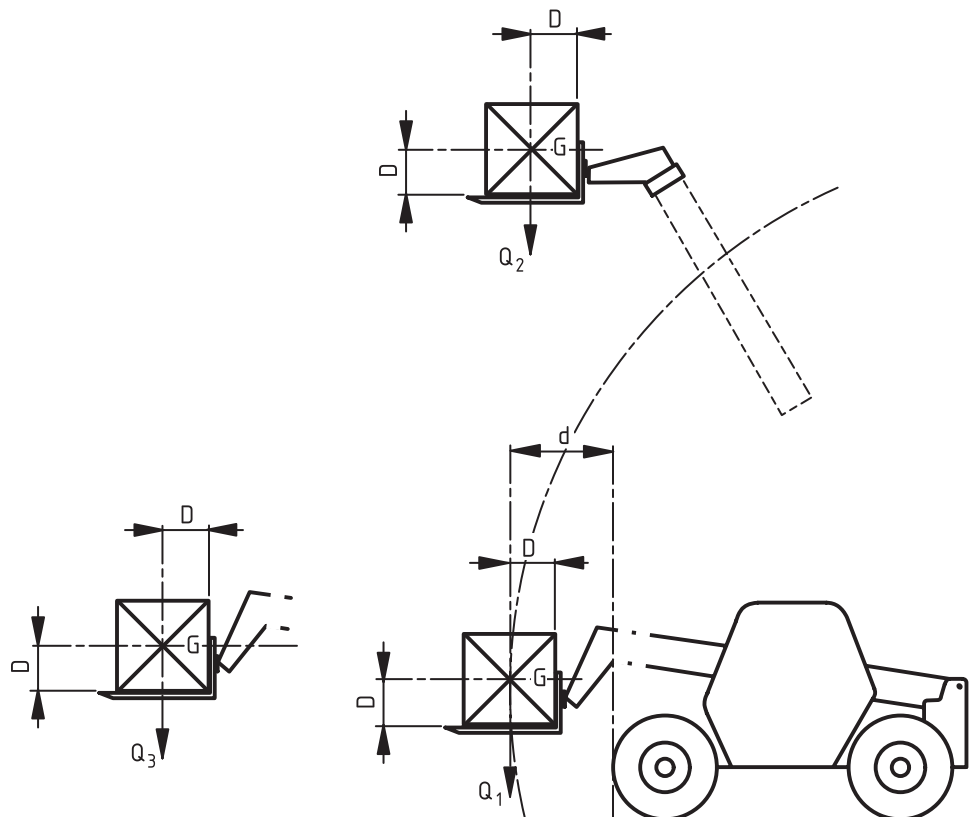

Key

- d reach
- D standard load centre distance
- G centre of gravity of the load
- Q_1 rated capacity
- Q_2 actual capacity at maximum lift height with forks
- Q_3 actual capacity at maximum reach

Figure A.1 — Parameters for designation of rated capacity of truck with fork arms

A.2 Rated capacity with spreader

The parameters for designating the rated capacity with spreader, defined in 3.19, are shown in Figure A.2, including the second container.

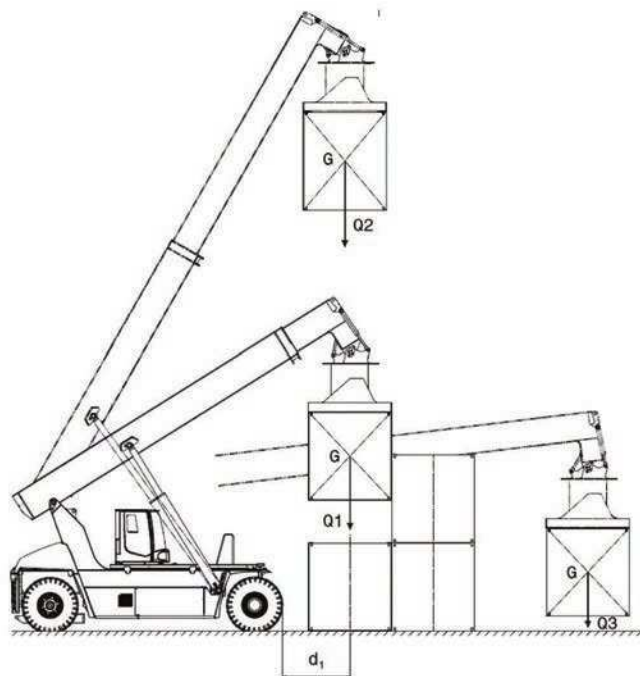

Key

- d_1 distance between two vertical parallel planes (tangent to front outside diameter of front tyres, to centre of gravity for 1st container row)
- G determined by centre of connection points (e.g. twist locks) on spreader attachment
- Q_1 rated capacity
- Q_2 actual capacity at maximum lift height with spreader
- Q_3 actual capacity at maximum reach

Figure A.2 — Parameters for designation of rated capacity with spreader

A.3 Standard load centre distance, D

A.3.1 Standard load centre distance with fork arms

The standard load centre distance for a truck with fork arms is the distance, D , expressed in millimetres, from the centre of gravity, G , of the load measured horizontally to the front face of the fork shanks and vertically to the upper face of the fork blades as shown in Figure A.1 and specified in Table A.1.

Trucks may be rated for special application(s) with load centre distances related to those applications and different from those listed below

Table A.1 — Standard load centre distance

Rated load, Q kg		Standard load centre distance, D mm					
		400	500	600	900	1 200	1 500
0	< 1 000	X					
$\geq 1\ 000$	< 5 000		X	X ^a			
$\geq 5\ 000$	< 10 000			X			
$\geq 10\ 000$	< 20 000			X	X	X	
$\geq 20\ 000$	< 25 000				X	X	
$\geq 25\ 000$						X	X

^a 600 mm is used in USA, Australia and Asia.

A.3.2 Standard load centre distance with spreader

The standard load centre is determined by the connection points to the container and at a height that corresponds to the mid-point of the height of a 2 590 mm container.

Annex B (informative)

List of significant hazards

This list contains the significant hazards, hazardous situations and events, as far as they are dealt with in this part of ISO 3691, identified by risk assessment of industrial trucks and which require action to eliminate or reduce the risk. See [Table B.1](#).

NOTE The structure of the table is based on that of ISO 12100:2010, Table B.1. The order of lines within a group corresponds to the truck functionalities.

Table B.1 — List of significant hazards

No.	Type or group/origin	Potential consequences	Corresponding requirement	
1	Mechanical hazards			
	— Acceleration, deceleration (kinetic energy)	— Being run over	4.1.5	Electrical requirements
		— Crushing	4.1.6	Stored energy components
	— Machinery mobility	— Drawing-in or trapping	4.2	Starting/moving
	— Moving elements		4.3	Brakes
	— Rotating elements	— Impact	4.4	Manual control actuators
			4.6.2.1.3	Maximum load lowering speed
			4.6.3	Hydraulic system
			4.6.3.3	Failure of energy supply to hydraulic circuit
			4.6.3.4	
			4.6.7	Fluid purification
			4.7.2	Load-handling attachments
			4.7.5	Operator's seat
			4.7.3	Protection from road wheels
			4.9.4	Operator restraint
			4.9.5	Warning device
			Clause 5	Starter battery requirements
			Clause 6	Verification of safety requirements and/or protective measures
				Information for use

Table B.1 (continued)

No.	Type or group/origin	Potential consequences	Corresponding requirement
	<ul style="list-style-type: none"> — Angular parts — Approach of a moving element to a fixed part — Cutting parts — Sharp edges 	<ul style="list-style-type: none"> — Crushing — Cutting or severing — Drawing-in or trapping — Entanglement — Shearing — Stabbing or puncture 	<ul style="list-style-type: none"> 4.1.4 Edges or angles 4.1.6 Stored energy components 4.2 Starting/moving/Travel controls/Pedestrian-controlled trucks 4.4.1.3 Additional operator or passenger positions 4.5.4 Access to engine and other compartments 4.7 Operator positions 4.7.5 Protection from road wheels and objects thrown up by the wheels 4.7.7 Protection against crushing, shearing and trapping 4.13 Devices for towing Clause 6 Information for use
	<ul style="list-style-type: none"> — Elastic elements 	<ul style="list-style-type: none"> — Crushing — Impact — Cutting or severing — Shearing — Stabbing or puncture 	<ul style="list-style-type: none"> 4.1.6 Stored energy components Clause 6 Information for use
	<ul style="list-style-type: none"> — Falling objects 	<ul style="list-style-type: none"> — Crushing — Impact 	<ul style="list-style-type: none"> 4.4.4 Load-handling controls 4.6 Systems for lifting and tilting 4.8 Stability 4.9.1 Overhead guard 4.9.2 Load backrest extension 4.11 Operator's cab/General 4.12 Provision for transportation of the truck Clause 5 Verification of safety requirements and/or protective measures Clause 6 Information for use
	<ul style="list-style-type: none"> — Gravity (stored energy) 	<ul style="list-style-type: none"> — Crushing — Impact 	<ul style="list-style-type: none"> 4.4.4 Load-handling controls 4.6 Systems for lifting and tilting 4.9.1 Overhead guard 4.9.2 Load backrest extension 4.11 Operator's cab/General Clause 5 Verification of safety requirements and/or protective measures Clause 6 Information for use

Table B.1 (continued)

No.	Type or group/origin	Potential consequences	Corresponding requirement	
	<ul style="list-style-type: none"> — Height from the ground — High pressure — Rough, slippery surface — Stability 	<ul style="list-style-type: none"> — Being thrown — Crushing — Drawing-in or trapping — Impact — Slipping, tripping and falling — Injection — Slipping, tripping and falling — Being thrown — Crushing — Impact 	<ul style="list-style-type: none"> 4.6 4.7.1 4.7.4 4.8 Clause 5 Clause 6 4.1.6 4.5.5 4.6.3 Clause 5 Clause 6 4.7.4.2 4.7.4.3 4.4.4 4.6 4.8 4.12 Clause 5 Clause 6 	<ul style="list-style-type: none"> Systems for telescoping, lifting and tilting Operator position/Dimension Operator access and egress Stability Verification of safety requirements and/or protective measures Information for use Stored energy components Liquefied petroleum gas (LPG)-powered trucks Hydraulic systems Verification of safety requirements and/or protective measures Information for use Steps Compartment floors Load-handling controls Systems for telescoping, lifting and tilting Stability Provision for transportation of the truck Verification of safety requirements and/or protective measures Information for use
2	Electrical hazards			
	<ul style="list-style-type: none"> — Arc — Electromagnetic phenomena — Electrostatic phenomena — Live parts — Not enough distance to live parts under high voltage — Overload — Parts which have become live under fault conditions — Short-circuit — Thermal radiation 	<ul style="list-style-type: none"> — Burn — Chemical effects — Electrocutation — Falling, being thrown — Fire — Projection of molten particles — Shock 	<ul style="list-style-type: none"> 4.1.5 4.12.3 Clause 5 Clause 6 	<ul style="list-style-type: none"> Electrical requirements Electromagnetic compatibility Verification of safety requirements and/or protective measures Information for use
3	Thermal hazards			

Table B.1 (continued)

No.	Type or group/origin	Potential consequences	Corresponding requirement	
	<ul style="list-style-type: none"> — Explosion — Flame — Objects or materials with a high or low temperature — Radiation from heat sources 	<ul style="list-style-type: none"> — Burn — Dehydration — Discomfort — Frostbite — Injuries by the radiation of heat sources — Scald 	4.1.2 4.1.5 4.3 4.5.1 4.5.3 4.5.5 4.7.6 4.11.3 4.11.7 Clause 5 Clause 6	Normal climatic conditions Electrical requirements Brakes Exhaust and cooling systems Fuel tank Liquefied petroleum gas (LPG)-powered trucks Protection from burning Operator's cab/Fire resistance Heater, demister and defroster Verification of safety requirements and/or protective measures Information for use
4	Noise hazards			
	<ul style="list-style-type: none"> — Exhausting system — Moving parts 	<ul style="list-style-type: none"> — Discomfort — Loss of awareness — Loss of balance — Permanent hearing loss — Stress — Tinnitus — Tiredness 	4.12.1	Noise emissions
5	Vibration hazards			
	<ul style="list-style-type: none"> — Mobile equipment 	<ul style="list-style-type: none"> — Discomfort — Low-back morbidity — Neurological disorder — Osteo-articular disorder — Trauma of the spine — Vascular disorder 	4.12.2	Vibration
6	Radiation hazards			
	No origin of these kinds of hazards in industrial trucks covered by this part of ISO 3691.			
7	Material/substance hazards			

Table B.1 (continued)

No.	Type or group/origin	Potential consequences	Corresponding requirement	
	<ul style="list-style-type: none"> — Combustible — Explosive — Flammable — Fluid — Fume — Gas 	<ul style="list-style-type: none"> — Breathing difficulties, suffocation — Cancer — Corrosion — Effects on reproductive capability — Explosion — Fire — Infection — Mutation — Poisoning — Sensitization 	<ul style="list-style-type: none"> 4.1.5 4.5.3.1 4.5.3.2 4.5.5 4.11.4 Clause 6 	<ul style="list-style-type: none"> Electrical requirements Tank isolation Fuel spillage Liquefied petroleum gas (LPG)-powered trucks Operator’s cab/Ventilation Information for use
8	Ergonomic hazards			
	<ul style="list-style-type: none"> — Access — Design or location of indicators and visual display units — Design, location or identification of control devices — Effort — Local lighting — Mental overload/underload — Posture — Repetitive activity — Visibility 	<ul style="list-style-type: none"> — Discomfort — Fatigue — Musculoskeletal disorder — Stress Any other (e.g. mechanical, electrical) as a consequence of human error 	<ul style="list-style-type: none"> 4.1.2 4.1.5 4.4 4.5.1 4.5.2 4.7.1 4.7.2 4.7.4 4.10 4.11 Clause 6 	<ul style="list-style-type: none"> Normal climatic conditions Electrical requirements Manual control actuators Exhaust and cooling system Cooling system Operator position/Dimensions Operator’s seat Operator access and egress Visibility/Lighting Operator’s cab Information for use
9	Hazards associated with environment in which the machine is used			
	<ul style="list-style-type: none"> — Dust and fog — Electromagnetic disturbance — Lightning — Moisture — Temperature — Water — Lack of oxygen 	<ul style="list-style-type: none"> — Burn — Slight disease — Slipping, falling — Suffocation Any other as a consequence of the effect caused by the sources of the hazards on the machine or parts of the machine 	<ul style="list-style-type: none"> 4.1.2 4.10 Clause 6 	<ul style="list-style-type: none"> Normal climatic conditions Visibility/Lighting Information for use
10	Combination of hazards			
	E.g. repetitive activity + effort + high environmental temperature	E.g. dehydration, loss of awareness, heat stroke	<ul style="list-style-type: none"> 4.1.2 Clause 6 	<ul style="list-style-type: none"> Normal climatic conditions Information for use

Bibliography

- [1] ISO 3691-1:2011, *Industrial trucks — Safety requirements and verification — Part 1: Self-propelled industrial trucks, other than driverless trucks, variable-reach trucks and burden-carrier trucks*
- [2] ISO 6489 (all parts), *Agricultural vehicles — Mechanical connections between towed and towing vehicles*
- [3] ISO 6682, *Earth-moving machinery — Zones of comfort and reach for controls*
- [4] ISO 10263-5:2009, *Earth-moving machinery — Operator enclosure environment — Part 5: Windscreen defrosting system test method*
- [5] ISO 12508:1994, *Earth-moving machinery — Operator station and maintenance areas — Bluntness of edges*
- [6] ISO 12509:2004, *Earth-moving machinery — Lighting, signalling and marking lights, and reflex-reflector devices*
- [7] ECE R43, Safety glazing. Regulation 43, Economic Commission for Europe, Inland Transport Committee, World Forum for Harmonization of Vehicle Regulations

